

**LECTURER NOTES  
ON  
SPONGE IRON & FERRO ALLOY**



**Government Polytechnic,  
Jaipur**

**BY P.ARADHANA  
LECTURER METALLURGY**

# SPONGE IRON AND FERRO ALLOY

## CHAPTER 01 REVIEW OF SPONGE IRON MAKING PROCESS:

### HISTORICAL DEVELOPMENT

- During the past century, many efforts were made to develop processes for producing iron for steelmaking that could serve as alternatives and/or supplements to the conventional blast furnace.
- Many of these projects were stimulated by a desire or necessity to use lower grade ores and available fuels that are unsuitable for the blast furnace.
- Processes that produce iron by reduction of iron ore below the melting point of the iron produced are generally classified as direct reduction processes and the products referred to as direct reduced iron (DRI). The processes that produce a molten product, similar to blast furnace hot metal, directly from ore are classified as direct smelting processes.
- In some of the more ambitious projects, the objective is to produce liquid steel directly from ore and these processes are classified as direct steelmaking processes.
- These broad categories are clearly distinguished by the characteristics of their respective products, although all of these products may be further treated to produce special grades of steel in the same refining or steelmaking process.
- While the blast furnace is expected to remain the world's chief source of iron units for steelmaking as long as adequate supplies of suitable coking coals remain available at competitive cost, DRI contributes 3–4% of the world's total iron making capacity with approximately 42 million annual tonnes (Mt/y) of DRI capacity having been installed in the free world as of 1997.
- As of the end of 1996 there were 15.5 Mt/y of direct reduction capacity under construction, which is expected to increase world's DRI production to 55 Mt/y by the year 2000 and 70 Mt/y by the year 2005. The major part of DRI production is used as a substitute for scrap in the electric arc steelmaking furnace (EAF). DRI derived from virgin iron units is a relatively pure material which dilutes contaminants in the scrap and improves the steel quality.
- The availability of low cost scrap and the high cost of energy restrict the use of DRI in most highly industrialized countries. Direct reduction processes are favoured in those locations with abundant reserves of inexpensive natural gas, non-coking coals and/or hydroelectric power, and that have access to suitable iron ores or agglomerates.
- Sponge iron provided the main source of iron for many centuries before the blast furnace was developed. In historic times, sponge iron was produced in shallow hearths, which used charcoal as reductant fuel.
- The product of these early smelting process was a sponge mass of coalesced granules of nearly pure iron intermixed with considerable slag.

## **THE REASONS FOR THE GROWTH OF THE SPONGE IRON INDUSTRY COULD BE ATTRIBUTED TO :**

- The advantages of using sponge iron in electric arc furnaces, partly substituting scrap, the conventional charge to the furnaces.
- The industry is gaining further importance due to proven utility of sponge iron in other steel manufacturing processes like L.D. Converters, Open Hearth Furnaces (OHFs), Blast Furnaces (BFs) & Basic Oxygen Furnaces (BOFs), Induction Furnaces (IFs) and Cupolas.

## **ADVANTAGES OF USING SPONGE IRON IN STEEL MAKING :**

1. Use of sponge iron:
2. Increases productivity through shorter tap-to-tap time and refining time.
3. Simultaneous melting and refining with continuous charging.
4. Faster metallurgical reactions and Improved as well as more stable power consumption
5. Less electrode consumption due to stable power.
6. More precise of steel compositions and quality advantages.
7. High degree of metallization (up to 92%) and consistent chemical composition.
8. Deep drawing steel grades can be produced in electric arc furnace (EAF).
9. Flat products and alloy steels of international standards can be made in electric arc furnace (EAF).

## **THE ADVANTAGES OF SPONGE IRON USE IN EAFs ARE SUMMARISED BELOW:-**

1. Uniform known composition
2. Low levels of residuals/tramp elements
3. Capability to maintain phosphorous level in steel within 0.002%
4. Maintenance of sulphur in steel by its removal in sponge
5. Manufacture.
6. Low content of dissolved gases
7. Uniform size and higher bulk density as compared to scrap
8. Capability of forming protective cover of foamy slag in the bath

9. Lower refining requirements of steel produced
10. Potential of sensible heat recovery from waste gases
11. Possibility of producing variety of steels

#### **SPONGE IRON OR DIRECT REDUCED IRON (DRI) :**

- Sponge iron is the metallic product formed by the reduction (removal of oxygen) of iron ore at temperature below the fusion point of iron while it is still in solid state. It is also called direct reduced iron (DRI).
- Direct-reduced iron (DRI) is produced from direct reduction of iron ore (in the form of lumps, pellets or fines) by a reducing gas produced from natural gas or coal.
- The reducing gas is a mixture of majority of hydrogen (H<sub>2</sub>) and carbon monoxide (CO). This process of directly reducing the iron ore in solid form by reducing gases is called direct reduction.
- A broadly used iron source is also a product known as direct reduced iron ("DRI") which is produced by the solid state reduction of iron ore to highly metalized iron without the formation of liquid iron.
- Sponge iron is the product created when iron ore is reduced to metallic iron, in the presence of coal, at temperatures below the melting point of iron. The external shape of the ore is retained with 30% reduction in weight due to oxide reduction resulting in change in true density from 4.4 gm/cc to 7.8 gm/cc in this product

## CHAPTER 2 THERMODYNAMICS OF SPONGE IRON MAKING

### PRINCIPLES OF DIRECT REDUCTION REACTIONS:

- Direct reduction is the conversion of iron oxide to the metallic iron entirely in solid state
- It uses haematite( $\text{Fe}_2\text{O}_3$ ) as raw material & non coking coal as reductant.
- The carbon in the coal gets converted to CO which subsequently reacts with  $\text{Fe}_2\text{O}$  to produce metallic iron .the overall reaction is  
 $\text{Fe}_2\text{O}_3 + 3\text{CO} \rightarrow 2\text{Fe} + \text{CO}_2$
- The reduction process proceeds in several steps as represented below  
Haematite  $\rightarrow$  magnetite  $\rightarrow$  wustite  $\rightarrow$  metallic iron  
 $\text{Fe}_2\text{O}_3 \rightarrow \text{Fe}_3\text{O}_4 \rightarrow \text{FeO} \rightarrow \text{Fe}$
- The degree of reduction in each step of the above progressive reduction involves a series of complex reactions

These reduction reactions with their enthalpies at 25 degree C are as follows

- $3\text{Fe}_2\text{O}_3 + \text{CO} \rightarrow 2\text{Fe}_3\text{O}_4 + \text{CO}_2$ ..... (1)
  - $\text{Fe}_3\text{O}_4 + \text{CO} \rightarrow 3\text{FeO} + \text{CO}_2$  ..... (2)
  - $\text{FeO} + \text{CO} \rightarrow \text{Fe} + \text{CO}_2$ ..... (3)
  - $\text{C} + \frac{1}{2}\text{O}_2 \rightarrow \text{CO}$ ..... (4)
  - $\text{CO} + \frac{1}{2}\text{O}_2 \rightarrow \text{CO}_2$  .....(5)
  - $\text{CO}_2 + \text{C} \rightarrow 2\text{CO}$ .....(6)
- The energy necessary to remove oxygen from the iron oxide increases with the decreasing concentration of oxygen in the ore.
  - Thus more and more fuel is to be supplied in to the reactor as the reduction of the ore proceeds.
  - The heat requirement of the reactions is obtained from the burning coal in the hot bed and as well as from the oxidation of carbon monoxide(5).
  - Usually two sets of heterogeneous reactions take place in the reactor
    - SET 1: Between coal ,  $\text{O}_2$  and  $\text{CO}_2$  particularly in coal based DRI.
    - SET 2: Between iron ore and CO particularly in gas based DRI.

### SET1 : BETWEEN COAL , $\text{O}_2$ AND $\text{CO}_2$ PARTICULARLY IN COAL BASED DRI:

- Carbon from the coal reacts with oxygen to form carbon dioxide with release of heat.
- The heat released raised and maintain the operating temperature inside the kiln.
- As the carbon dioxide emerges from the bed it react with fresh carbon to form carbon monoxide.
- then carbon monoxide is available for reduction of iron in the subsequent stages

### SET 2: BETWEEN IRON ORE AND CO PARTICULARLY IN GAS BASED DRI:

- Each ore particle may be considered to be porous as it contains large numbers of micro pores.

- Further the reaction between the ore particle and gaseous reactants is thought to occur in five successive steps discussed below.

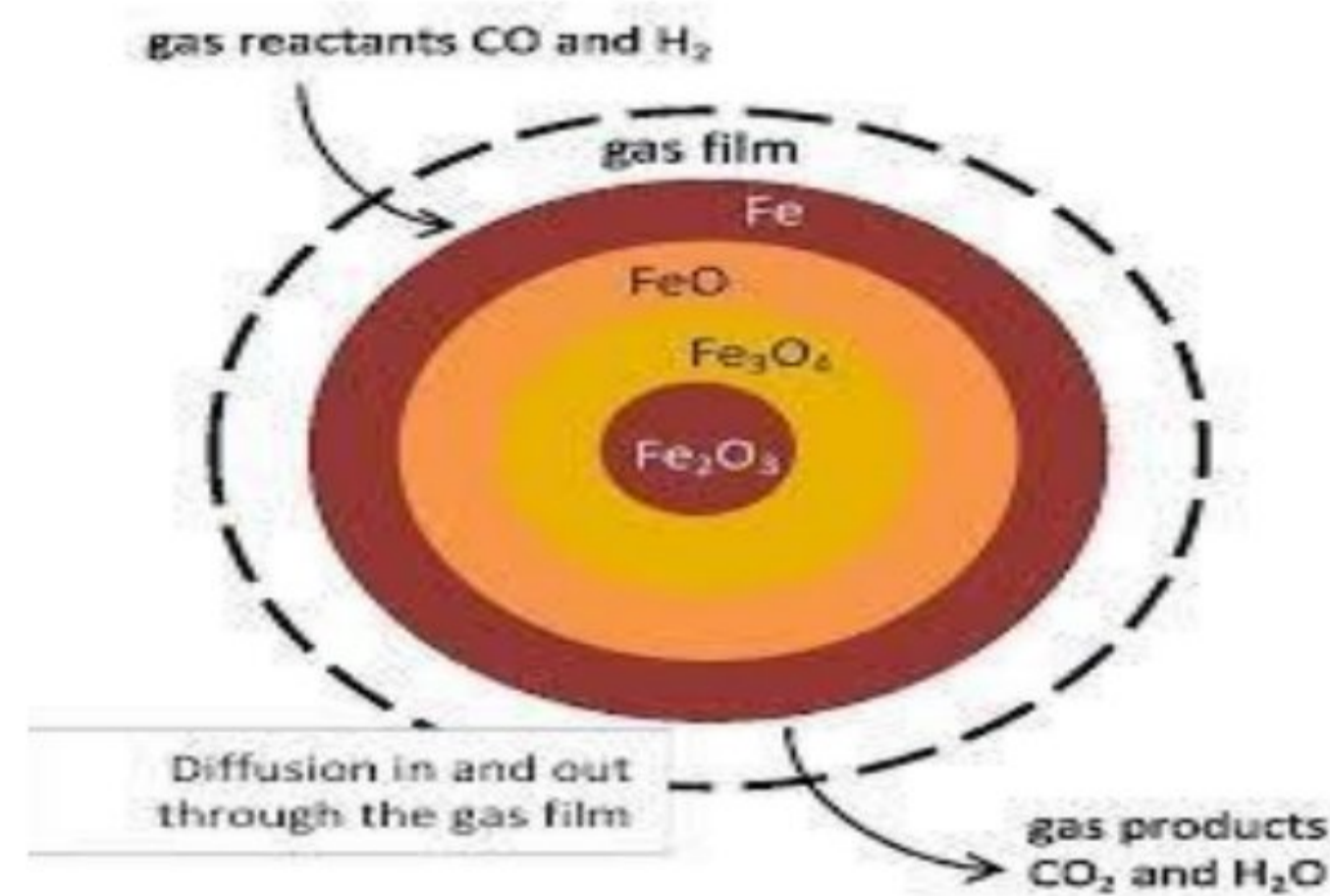

- Step1;diffusion of gaseous reactant through the film surrounding the solid ore particle.
- Step2:penetration and diffusion of reactants through the layer of already reacted outer zone to the interface of the unreacted core of the ore
- Step3:reaction at the reduced-unreduced interface by the gaseous reactant in the solid
- Step4:diffusion of gaseous product through the reacted layer to the exterior surface of the solid
- Step5:diffusion of gaseous product through the gaseous film surrounded the ore particle to the outer atmosphere.

### REACTION MECHANISM IN COAL BASED DRI:

- Although it is a solid–solid reaction, it takes place via a gas–solid reaction:
  - $3\text{Fe}_2\text{O}_3 + \text{CO} \rightarrow 2\text{Fe}_3\text{O}_4 + \text{CO}_2$ ..... (1)
  - $\text{Fe}_3\text{O}_4 + \text{CO} \rightarrow 3\text{FeO} + \text{CO}_2$ ..... (2)
  - $\text{FeO} + \text{CO} \rightarrow \text{Fe} + \text{CO}_2$ ..... (3)
  - $\text{CO}_2 + \text{C} \rightarrow 2\text{CO}$ ..... (4)
- The carbon monoxide required for the above reaction is generated by the carbon in the coal feed reacting with the carbon dioxide produced by the reduction reaction.
- This reaction is known as Boudouard reaction, may be represented as
  - $\text{CO}_2 + \text{C} \rightarrow 2\text{CO}$

### REACTION MECHANISM IN GAS BASED DRI:

- In gas-based DR process, the reducing agent is a mixture of CO and H<sub>2</sub>.

- THE reduction occurs due to H<sub>2</sub> gas as
  - $3 \text{Fe}_2\text{O}_3 + \text{H}_2 \rightarrow 2 \text{Fe}_3\text{O}_4 + \text{H}_2\text{O}$
  - $\text{Fe}_3\text{O}_4 + \text{H}_2 \rightarrow 3\text{FeO} + \text{H}_2\text{O}$
  - $\text{FeO} + \text{H}_2 \rightarrow \text{Fe} + \text{H}_2\text{O}$
- In gas-based DR process, the reducing agent is a mixture of CO and H<sub>2</sub>. The interconversion reaction between CO and H<sub>2</sub>O takes place according to the following reaction:
  - $\text{CO} + \text{H}_2\text{O} = \text{CO}_2 + \text{H}_2$

### REDUCTION BY CARBON MONOXIDE(indirect reduction):

- Above 5700C, iron oxide is reduced by CO in three stages:
  - $3 \text{Fe}_2\text{O}_3 + \text{CO} \rightarrow 2 \text{Fe}_3\text{O}_4 + \text{CO}_2$
  - $\text{Fe}_3\text{O}_4 + \text{CO} \rightarrow 3\text{FeO} + \text{CO}_2$
  - $\text{FeO} + \text{CO} \rightarrow \text{Fe} + \text{CO}_2$
- Below 5700C, Fe<sub>3</sub>O<sub>4</sub> is directly reduced to Fe bypassing the wustite (FeO) stage

### REDUCTION BY HYDROGEN (INDIRECT REDUCTION):

- Reduction by Hydrogen occurs in three stages as follows:
  - $3 \text{Fe}_2\text{O}_3 + \text{H}_2 \rightarrow 2 \text{Fe}_3\text{O}_4 + \text{H}_2\text{O}$
  - $\text{Fe}_3\text{O}_4 + \text{H}_2 \rightarrow 3\text{FeO} + \text{H}_2\text{O}$
  - $\text{FeO} + \text{H}_2 \rightarrow \text{Fe} + \text{H}_2\text{O}$

### REDUCTION BY CARBON (DIRECT REDUCTION):

- For solid carbon in a DR process, the following three reduction reaction can be written:
  - $3\text{Fe}_2\text{O}_3 + \text{C} \rightarrow 2\text{Fe}_3\text{O}_4 + \text{CO}$
  - $\text{Fe}_3\text{O}_4 + \text{C} \rightarrow 3\text{FeO} + \text{CO}$
  - $\text{FeO} + \text{C} \rightarrow \text{Fe} + \text{CO}$
- Only a negligible amount of reduction will occur by direct contact of carbon particles with iron oxide particles since such solid-solid reactions are very slow. The actual reduction process occurs through the intermediary of CO.

### CARBON DEPOSITION:

- Carbon deposition on reduced iron takes place for the following reason:
  - At temperatures below 900degree the fine carbon formed by the reaction
    - $2\text{CO} = \text{CO}_2 + \text{C}$
  - At temperature above 900 degree carburization of reduced iron occur by the reaction
    - $3\text{Fe} + 2\text{CO} = \text{Fe}_3\text{C} + \text{CO}_2$

### REDUCIBILITY FACTOR OF SPONGE IRON:

This property of the iron ore depends on following factors:-

- **NATURE OF IRON OXIDE**  
The major deposition of iron oxide in nature is mainly in the form of hematite & magnetite. The oxygen enrichment in hematite iron ore is more than the magnetite.

Hematite iron ore is the saturation point of oxide ore which is more stable in nature. The purest hematite iron ore may contain maximum 1% of magnetic or magnetic in nature.

- **ORE SIZE**

The deposition of iron ore in nature is usually in hard and massive form. But when the ore is considered for DRI process its size and shape are very much important for the of reduction reactions.

- **POROSITY**

The porosity of ore is one of the important factors which affect the reducibility. It is observed that the reducibility of soft hematite iron ore is greater than that of hard hematite and magnetite ore. The reducibility of natural ore show that for 90% reduction, reciprocal of time varied linearly with percentage porosity.

- **NATURE & COMPOSITION OF GANGUE**

It observed that natural ore contains gangue oxide of Si, Al, Cr, Ti etc. in different from. In some of the ores wustite is present as complex compound such as  $2\text{FeOSiO}_2$ ,  $\text{FeOAl}_2\text{O}_3$ ,  $\text{FeOCr}_2\text{O}_3$  where wustite exist in a state of low activity. These oxides tend to the decrease the reducibility of iron ore in kiln in reducing atmosphere.

- **SWELLING**

Some ores show abnormal increase in volume at temperature between 900 to 1000°C. This is referred as swelling of ore. The cause of swelling has not been understood fully. Various investigators have in opinion that it is associated with mechanism of nucleation and growth having of wustite.

- **TEMPERATURE**

The rate of reduction of iron oxide increases with increase in temperature of iron oxide. In solid gas reduction it is advantageous to use a temperature above 1000° C because boundary reaction is maximum for producing CO with CO<sub>2</sub> and C combination. It is observed that if iron ore is reduced to metallic iron at low temperature, this forms a layer of dense metallic iron on the ore body which affects reduction at higher temperature region.

- **GAS COMPOSITIONS**

The coal after gasification becomes a composition of CO<sub>2</sub>, H<sub>2</sub>, some water vapors, CO<sub>2</sub> etc. It is observed that by increasing the partial pressure of reducing gases the rate of reduction can be increased. It has been proved that hydrogen is better reducing gas than CO but at higher degree of reduction CO reduce iron oxide at faster rate.

- **PRESSURE**

The increase in pressure is expected to increase the rate of reduction as increase the partial pressure of the reducing gas.



## CHAPTER 03 MAJOR DIRECT REDUCTION PROCESS:

### ❖ COAL-BASED PROCESSES

- Coal-based processes are broadly classified into two categories:
  1. Rotary kiln process
  2. Rotary hearth process

### ❖ COAL BASED DR PROCESS USING ROTARY KILN:

#### ❖ SL/RN PROCESS:

#### ❖ INTRODUCTION:

- The forerunner to the SL/RN process, the R-N process (for Republic Steel Company and National Lead Corpora) was developed in Norway.
- In 1964 Lurgi Chemie acquired the R-N patents and world rights and developed the technology further in cooperation with the Steel Company of Canada, Ltd. (Stelco) to form the SL/RN process.
- The reduction kiln is very similar to the system used in CODIR and the other coal based plants described later.
- The major differences between SL/RN and CODIR are that in SL/RN the product is cooled by indirect water sprays on the outside of the cooler, and the kiln off gas is cooled in a waste heat recovery boiler.
- By 1998, 15 SL/RN kilns were in operation in Brazil, India and South Africa for the production of DRI for steelmaking. Their combined annual capacity is about 1.68 million tonnes

#### ❖ PROCESS DESCRIPTION:

- The SL/RN process is fed with indurate pellets and/or lump iron ore.
- A wide range of fuels and reluctant including lignite, char, low temperature coke, coke breeze and anthracite coal have been used satisfactorily.
- Depending on the fuel used, the proportion of the reluctant fed through the inlet of the kiln with the oxide feed and the proportion fired through the burner at the kiln exit will be adjusted.
- With very low-volatile coal, a supplementary fuel such as natural gas or fuel oil is fed through the central burner or through the air tubes to maintain the proper temperature profile in the kiln.
- Smooth kiln operation is achieved when operating with a relatively high volatile coal charged together with the iron burden through the kiln feed end.
- Coals with a high reactivity, low free-swelling index and high ash fusion temperature are preferred.
- The coal should also be non-coking. A low ash fusion temperature will promote formation of accretions in the kiln.

- The coal ash composition is also important because a siliceous ash might react with ferrous oxide to form the low melting compound, ferrous silicate, and interfere with the reduction to metallic iron.

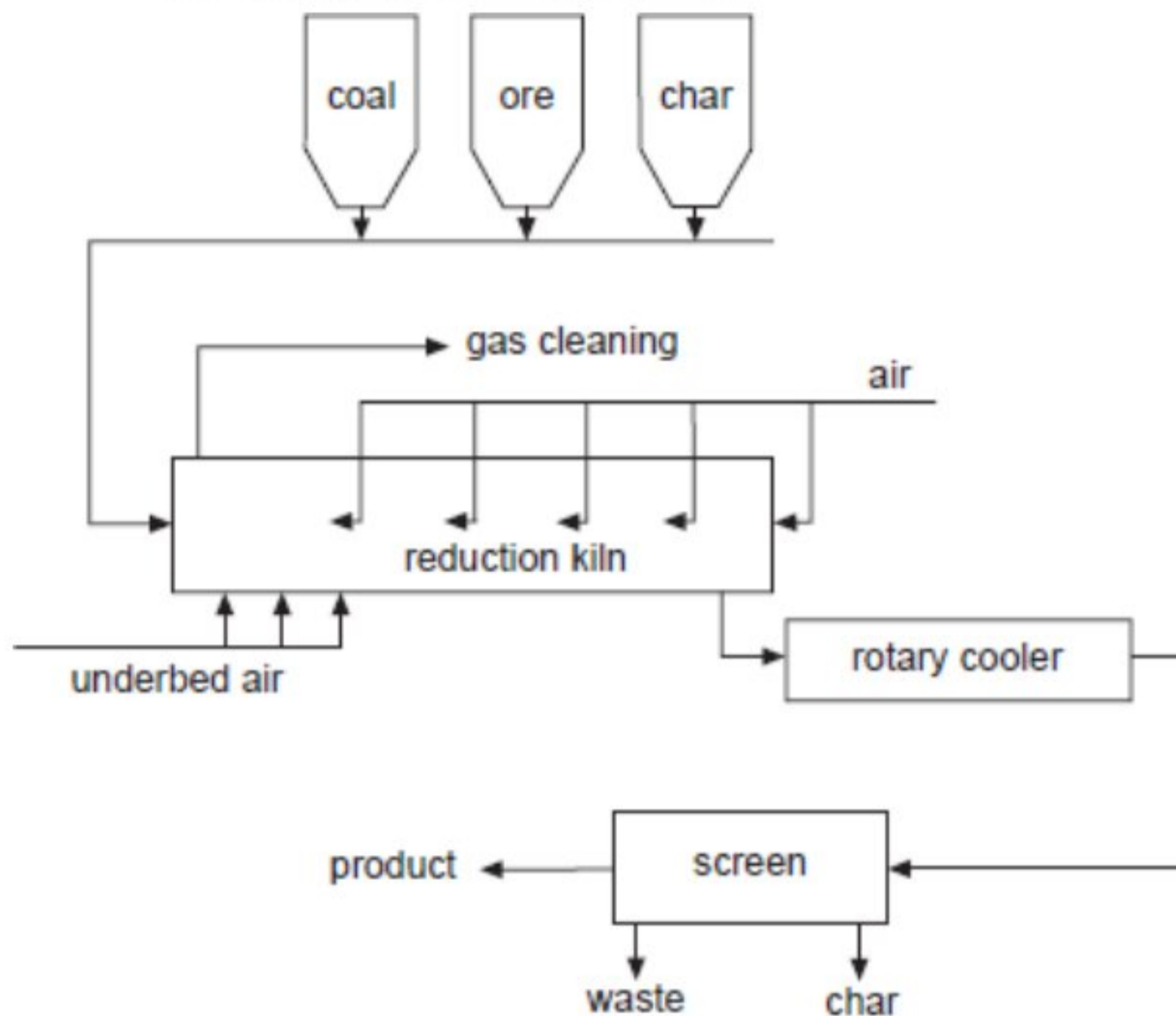

SL/RN direct reduction process flowsheet.

- The kiln exit gases pass through a settling chamber for coarse dust removal and a two-stage after-burner.
- Combustible gases are burned in the first stage, followed by fine carbon particles in the second stage.
- The afterburner chamber temperature is controlled by means of water sprays. In some plants, the gas emerging from the afterburner is passed through waste heat boilers, scrubbed and then discharged through the stack.
- The DRI is discharged at about 1000°C. An enclosed chute at the discharge removes lumps and transfers the hot DRI to a rotary cooler.
- The cooler, a horizontal metal cylinder 3.6 m (12 ft) diameter and 40–60 m (131–197 ft) long is immersed in a water trough and has water sprayed on the upper surface.
- The cooler discharges the DRI into a hopper, which serves as an air lock to prevent air ingress.
- Trommel screens located at the hopper outlet separate the discharge into fractions which then pass through magnetic separators. Screens downstream separate the nonmagnetic portions.
- Recent experiments show that air admitted through ports below the bed in the preheat zone will burn some of the gases that would otherwise leave the kiln unburned.
- Such a practice would also permit the use of lignite with up to 60% moisture without pre drying. This technique would greatly improve the efficiency of the process and arrangements are now being made to install it on several existing SL/RN kilns.

#### ❖ **PROCESS ADVANTAGES:**

1. Use of any iron bearing material.
2. Wide variety of reductants.
3. Proven DRI technology.
4. Economic production of DRI.

#### ❖ **ACCAR PROCESS:**

#### ❖ **INTRODUCTION:**

- The ACCAR process was developed by the Allis-Chalmers Corporation, Milwaukee, Wisconsin.
- The Allis-Chalmers Controlled Atmosphere Reactor (ACCAR) produces highly metalized DRI in a ported rotary kiln. Liquid, solid and gaseous fuels, singly or in combination, are used directly in the kiln without an external reformer or gasifying plant.
- The ACCAR kiln is equipped with an intricate port system and with valving arranged radially around the circumference of the kiln and spaced uniformly along its length for liquid and/or gaseous fuel injection under the bed and for air injection above it.
- The flow rates through the ports are controlled to maintain optimum temperature profile and gas composition along the length of the kiln. Versatility in the use of fuel permits use of the most economical fuels available.

#### **PROCESS DESCRIPTION:**

- Coal and ore lumps /pallets fed into the kiln are heated to reduction temperature. By the hot gasses flowing in counter current manner.
- Volatile matters released from coal during the heatup are carried away along exhaust gases.

- As the ore travels through the kiln reduction is accomplished by solid carbon and carbon monoxide gas.
- The coal feed rate is controlled in such a manner that it is fully consumed as the burden enters the final stage of reduction.
- The combustibles released from the burden are burned in the kiln along with air introduced through the port fitted on the kiln shell.
- The final stage of reduction is achieved by introducing liquid or gaseous fuels get converted to hydrogen and carbon monoxide and complete the ore reduction.
- Further carbon monoxide generated in the process provides a protective atmosphere to the metalized product against reoxidation during final stage of reduction.
- Then solid are discharged into a rotor cooler to accomplish cooling by external water spray.
- The DRI undergoes magnetic separation to remove gangue followed by screening to achieve graded product.

#### ❖ CODIR PROCESS:

#### ❖ INTRODUCTION:

- The CODIR Process was developed from the Waelz and Krupp-Renn processes which were developed for the zinc and direct reduction of iron industries in the 1920's and 1930's.
- The Waelz Process was used to recover zinc from low grade ores by reducing zinc oxide, volatilising the zinc which was collected for further processing. The Waelz Process uses a coal fired rotary kiln.

#### ❖ PROCESS:

- CODIR converts high grade lump ore and pellets into an iron product using low volatile coal as a reductant.

- Lump ore or pellets are fed into an inclined rotary kiln with the reductant and a desulphurising agent, usually dolomite or limestone, which are heated and reduced by a counter current hot gas flow.
- The kiln is heated from the discharge end using pulverised coal as the fuel, in a deficiency of air, further air injection occurs along the length of the kiln using tuyeres installed in the kiln shell.
- The air is injected axially in the direction of the gas flow to burn off CO evolving from the reduction process from the coal volatiles. A temperature profile of 950-1050C is maintained in the charge over the length of the kiln.
- A range of non-coking coals can be used as fuel coal in the process, however when high volatile coals are used the waste gas contains excess amounts of latent heat which cannot be fully combusted.

### CODIR PROCESS

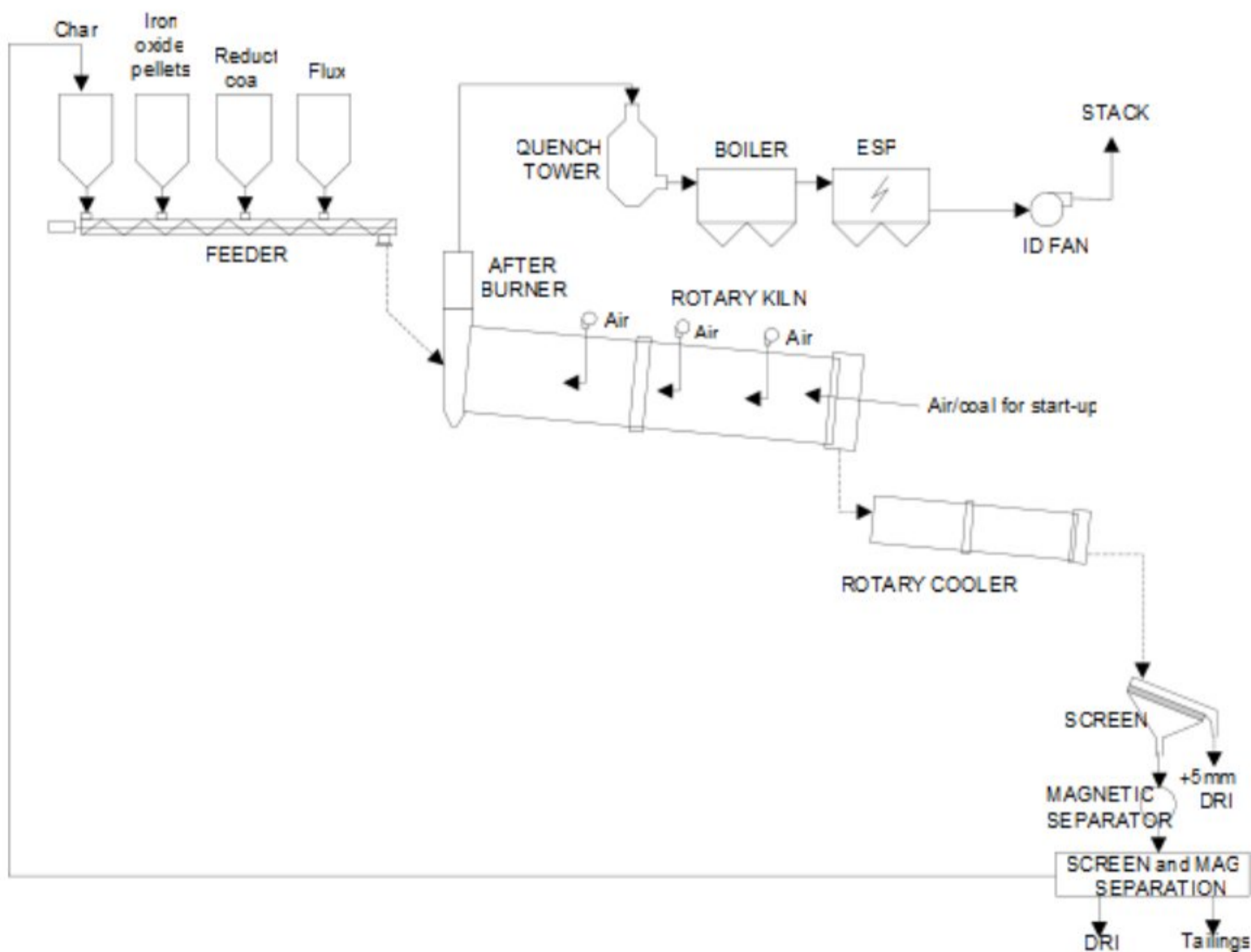

- Waste heat recovery has been adopted for the process, which will also recover energy from waste gases, from high volatile coals, which are burnt outside of the kiln in the waste gas system.
  - The product from the kiln is cooled in a rotary cooler by direct and indirect water cooling. The product is then screened, separated magnetically and by a gravity separation process.
- ❖ **ADVANTAGES**
- Use of any iron bearing materials in several forms
  - Wide variety of reductants can be used

❖ **COAL BASED PROCESSES USING REACTORS OTHER THAN ROTARY KILNS:**

❖ **KINGLON METER PROCESS:**

❖ **INTRODUCTION:**

- The Kinglor-Metor process produces iron continuously by heating a mixture of ore and coal in an externally-fired rectangular shaft or retort.
- Kinglor-Metor shafts are constructed with retort walls of highly conductive silicon carbide.
- Additional energy is provided by burning some of the carbon monoxide generated during reduction with air in a preheating zone in the upper part of the retort.
- A schematic flow sheet of the process given below:

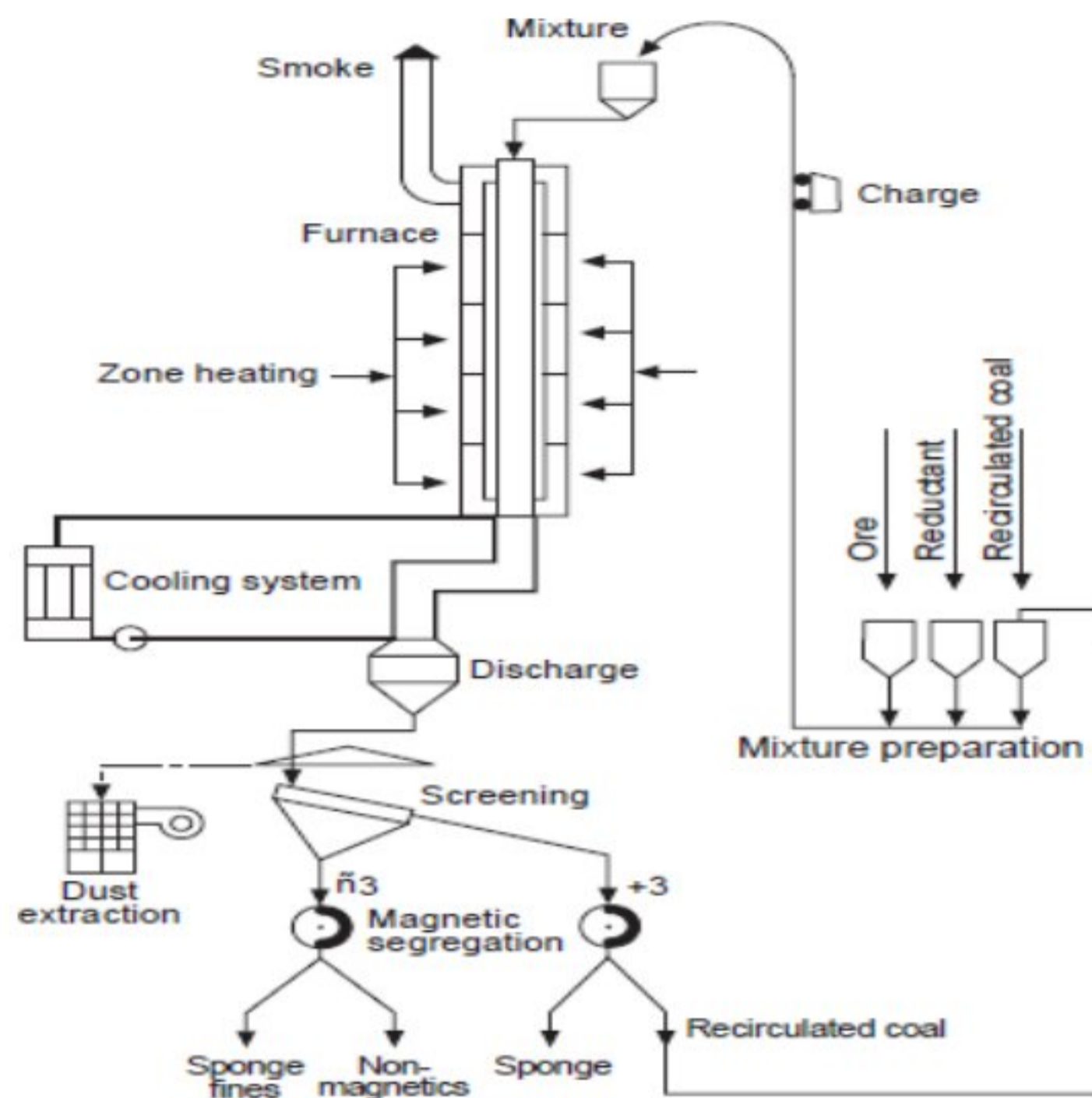

Schematic flowsheet of the Kinglor-Metor process.

## ❖ FASTMET PROCESS.

### ❖ INTRODUCTION

- The success of the RHF-based DRI technology has led to the development of the FASTMET process.
- Midrex Technologies in partnership with its parent company Kobe Steel, Ltd. has developed the FASTMET process as a carbon-based reduction technology, applicable for processing iron ore as well as iron oxide-containing materials such as steel mill wastes.
- From both economical and environmental points of view, the FASTMET process is very attractive as a proven technology for dust recycling.

### ❖ PROCESS:

- The FASTMET process is a solid reductant-based RHF process. Iron ore concentrate fines along with reductant fines (such as charcoal or other carbon-bearing solid) are pelletized to form iron oxide-carbon composite pellets, dried, and then charged directly to the RHF.





- The product can be cold DRI, hot DRI, HBI, or hot metal depending on end use requirements.
- The DRI produced is continuously discharged at around 1000\_C (1273 K) from the furnace, either into refractory-lined container for hot charging to the melt shop or into briquetting machines for the production of HBI or directly cooled in inert atmosphere to get directly reduced pellets.
- The carbon content in the product can be controlled between 1.0% and as high as 6.0%, if required. Additional heat from the exit gas of the process can be recovered by producing electrical power.
- FASTMET DRI (HBI) is melted by electric energy to produce hot metal, hence another name of the FASTMELT process.

### ❖ ITMK3 PROCESS.

#### ❖ INTRODUCTION:

- The ITmk3 process is considered to be the third generation of ironmaking technology, the first two generations comprising BF and DR processes.
- ITmk3 processes iron ore fines into almost pure pig iron nuggets within 10 minutes. The result is a conveniently sized, slag-free material ideally suited for further processing by conventional technologies into high-quality steel products and foundry iron castings.
- The Mesabi Nugget demonstration plant, commissioned in July 2004, achieved continuous, reliable production of pig iron nuggets under commercial operation conditions. Ten thousand metric tonnes of quality pig iron nuggets were produced during the four test campaigns.

#### ❖ PROCESS:

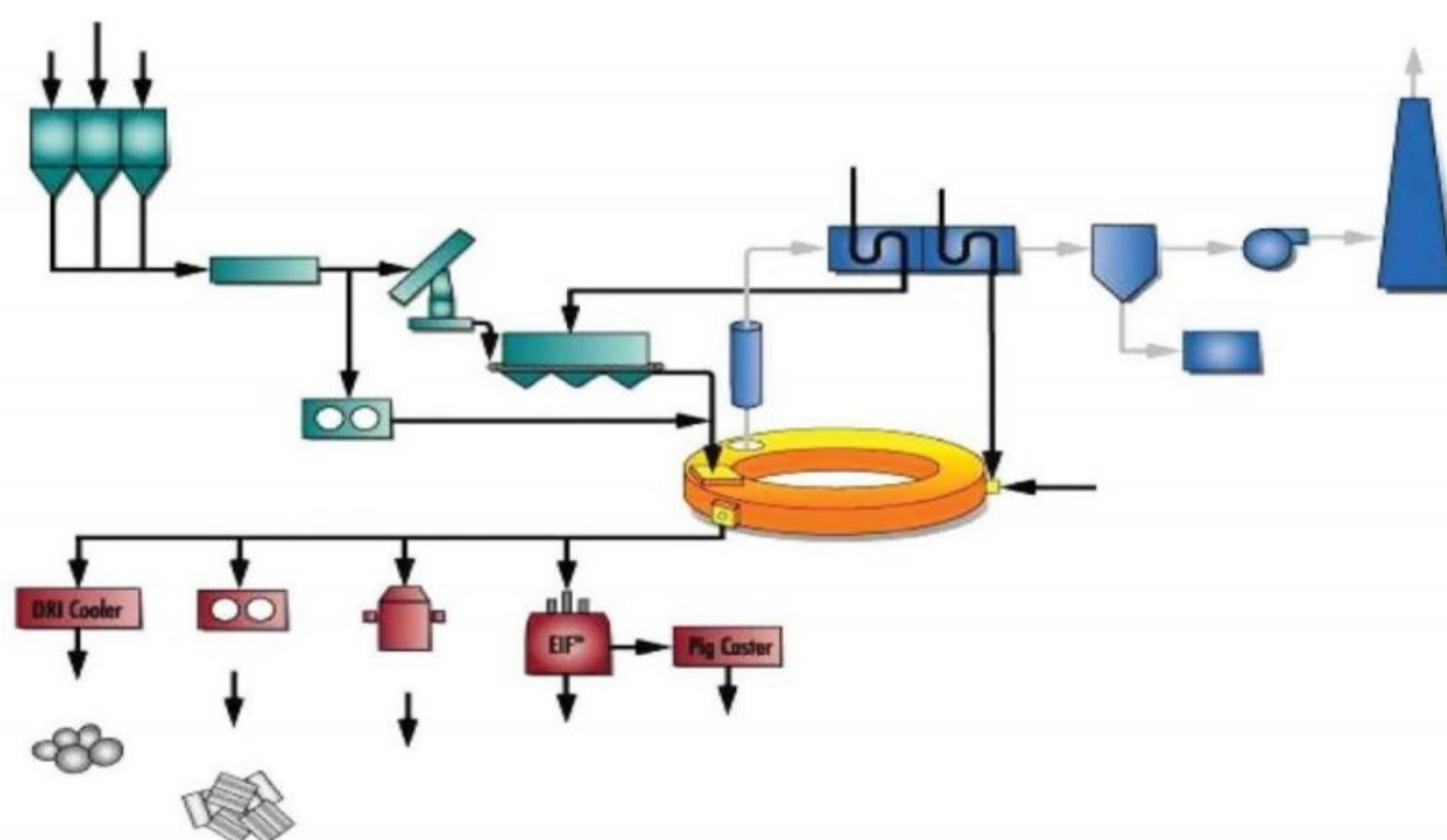

- In ITmk3, the iron ore fines and noncoking coal are formed into green iron ore-coal composite pellets.

- ITmk3 uses the same type of mixing and agglomeration steps and RHF as FASTMET.
- The composite pellets are fed to an RHF and heated to 1300–1450C (1573–1723 K); at this temperature range, the pellets are reduced to form iron nuggets.
- The temperature of RHF is raised thereby melting the reduced iron and enabling it to easily separate from the gangue.
- This ironmaking process takes only 10 minutes against 10 hours in the BF process and 8 hours in the rotary kiln process. Iron and slag get separated and the product is called nuggets.
- Iron nuggets can be fed directly into BOF or EAF as a pure iron source and a substitute of scrap. By substituting scrap, it can dilute tramp elements like Cu, Pb, Sn, and Cr.

#### ❖ GAS-BASED PROCESSES:

- Gas-based processes are broadly classified as follows:
  1. Midrex process
  2. HYL process
  3. Purofer process
  4. Finmet process
  5. High iron briquette (HIB) process

#### ❖ MIDREX PROCESS:

##### ❖ INTRODUCTION:

- The Midrex process was developed by the Surface Combustion Division of Midland-Ross Corporation in the mid-1960s.
- The Midrex Division became a subsidiary of Korf Industries in 1974. Midrex was subsequently acquired by Kobe Steel, Ltd. in 1983.
- The first commercial Midrex plant was installed near Portland, Oregon and started production in 1969. The plant included two shaft reduction furnaces of 3.4 m (11.2 ft) inside diameter and had a total capacity of 300,000 tonnes per year.
- The average energy consumption of this early plant was approximately 15 GJ/tonne (12.9 MBtu/ton) of DRI.
- Many difficult engineering and operating problems were solved during the first several years of operation of this plant that contributed significantly to the design, construction and operation of larger Midrex plants throughout the world.
- The Midrex™ Direct Reduction process is based upon a low pressure, moving bed shaft furnace where the reducing gas moves counter-current to the lump iron oxide ore or iron oxide pellet solids in the bed.
- The reducing gas (from 10-20% CO and 80-90% H<sub>2</sub>) is produced from natural gas using Midrex's CO<sub>2</sub> reforming process and their proprietary catalyst (instead of steam reforming).

##### ❖ PROCESS DESCRIPTION:

- The iron oxide feed to a Midrex shaft furnace can be in the form of pellets, lump ore or a mixture of the two (in 0 to 100% proportions).
- The solid feed is discharged into a feed hopper on top of a proportioning hopper that evenly distributes the solids into the shaft furnace.
- A dynamic seal leg keeps the reducing gas inside the furnace.

- The shaft furnace operates at low pressure, under 1 bar gauge, which allows dynamic seals to be used on the furnace inlet and discharge.
- The iron ore burden in the shaft furnace is first heated, then reduced by the upward flowing, counter-current reducing gas that is injected through tuyer located in a bustle distributor at the bottom of the cylindrical section of the shaft.

- The ore is reduced to a metallization typically in the range of 93% to 94% by the time it reaches the bustle area.
- Below the bustle area, it goes through a transition zone (with design to reduce agglomeration or lumping) and then reaches the lower conical section of the furnace.
- Lower carbon reduced iron (<1.5% C) is cooled using a circulating stream of cooled exhaust gas that is introduced in the conical section for cold DRI discharge.
- Higher carbon DRI (up to 4.0% C) can be produced by introduction of natural gas into this cooling gas. It readily reacts (and cracks) with the highly reactive metallic DRI.
- For hot discharge of DRI to be used for hot charging of EAF's (i.e. Midrex's Hotlink™ Process) or for feed to hot briquetting presses (to produce HBI), the lower part of the furnace is modified to allow handling of hot burden.
- The Midrex gas generation system consists of a CO<sub>2</sub> reformer using their own catalyst.
- The feed to the reformer is a mixture of process gas recycled from the furnace and makeup natural gas.
- The top gas leaving the shaft furnace at a temperature of 400 to 450C is cooled and dust is removed in a top gas scrubber.
- About two-thirds of the gas is recycled back to the process (process gas) and the rest is used as a fuel.
- The process gas is compressed, mixed with natural gas and is preheated in the reformer recuperates before entering the tubes of the reformer.

- The ratio of H<sub>2</sub> to CO is controlled at about 1.5 to 1.8, and reducing quality at 11 to 12 for best operation.

#### ❖ PROCESS ADVANTAGES:

- World-wide commercial use proven.
- Raw material flexibility.
- CO<sub>2</sub> reformer eliminates need for steam system, reformed gas quench, reducing gas heating and CO<sub>2</sub> removal system.

#### ❖ HYL PROCESS

##### ❖ INTRODUCTION:

- In the HYL process developed by Hojalata y Lamina S.A. (Hylsa) of Monterrey, Mexico, lump ore and fired pellets are reduced in fixed-bed retorts by reformed natural gas.
- The first commercial HYL plant was installed at Monterrey and started production late in 1957.
- This plant has a capacity of 200 tonnes per day of DRI and the reactors are approximately 2.5 m (8.2 ft) in diameter and hold approximately 15 tonnes of ore in a 1.5 m (4.9 ft) deep bed.
- The reactors in the more recent plants are 5.4 m (17.7 ft) in diameter and 15 m (49.2 ft) high.
- Design capacity is approximately 1900 tonnes per day of DRI having an average reduction of approximately 90%. The energy consumption in the most recent plants is 14.9 GJ/tonne (12.8 MBtu/ton) of 90% reduced DRI.
- In the more recent plants of the HYL II design, high temperature alloy tubes in the reducing gas reheating furnaces are used, which permits heating the gas to high temperatures, and the number of heating furnaces was reduced to two units from the original four units.
- In the HYL II process, reducing gas is generated by reforming natural gas with excess steam, to prevent carbon formation and to promote long catalyst life.
- The reducing section consists of a set of four reactors, three of which are in operation, while the fourth is engaged in discharging and charging operations. The HYL process is a cyclical batch operation, and the three on-line reactors operate in series.
- Reduction is performed in two stages, an initial reduction stage and a main reduction stage. Cooling, carburization (Fe<sub>3</sub>C) and the final adjustment of metallization are performed in the third stage.
- Each stage takes roughly three hours. An intricate system of valves permits the reactors to be connected in any desired order so that any one reactor can be connected in its correct process stage.
- In 1979, a 9,000 tonnes/yr pilot plant investigated moving-bed technology as an alternative to fixed-bed technology.

- The first moving bed plant was a conversion of the second plant at Monterrey. The four fixed-bed reactors were replaced by the new shaft furnace and the process, then called HYL-III, was started up in Monterrey.
- The compatibility of the HYL and HYL-III processes made it possible to convert and modernize HYL plants to the new technology.

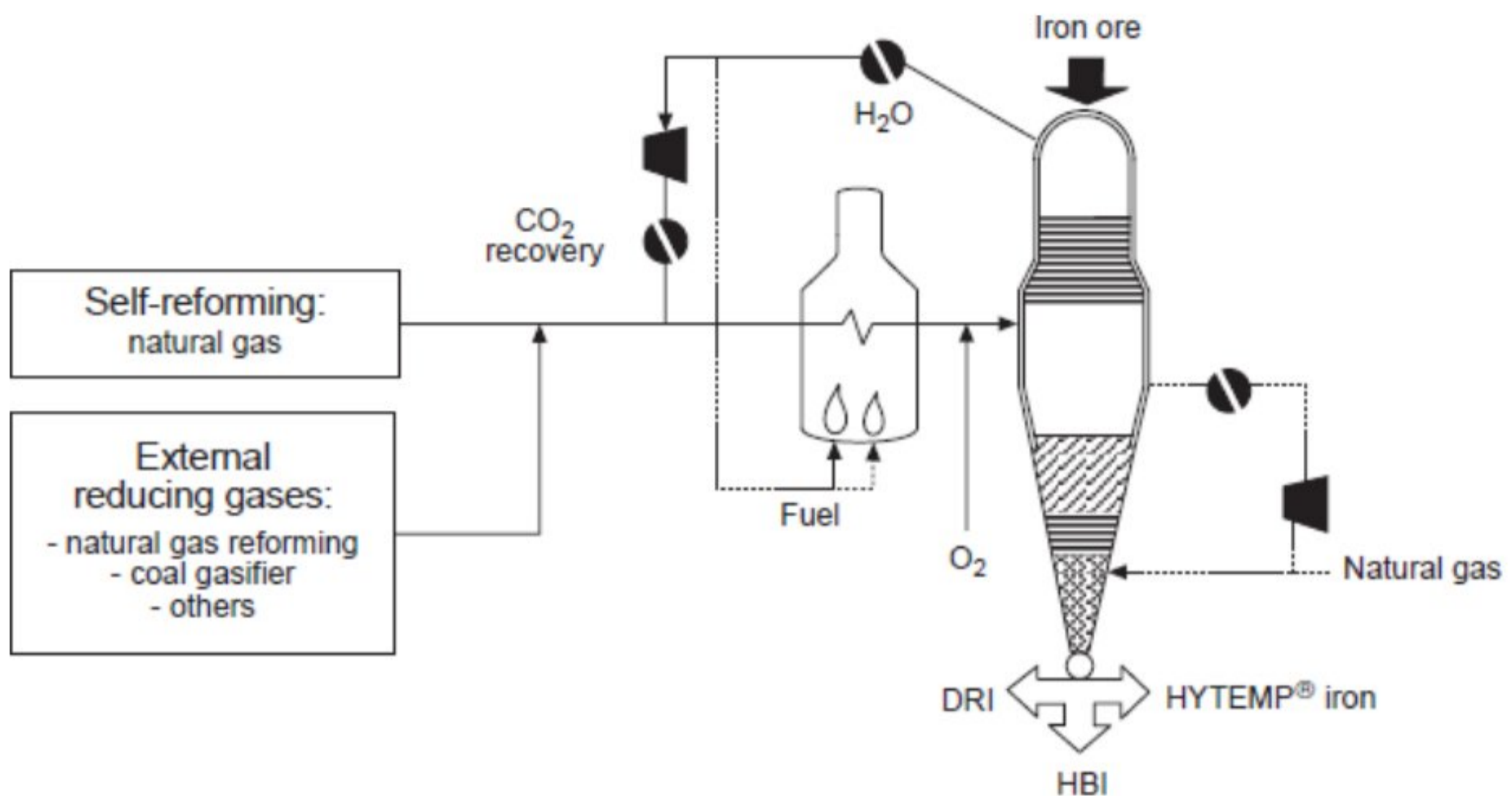

HYL process diagram.

#### ❖ PROCESS DESCRIPTION:

- The components in the reducing gas circuit are the reactor reduction zone, the top gas quenching/scrubbing system, the reducing gas recycle compressor, the CO<sub>2</sub> removal system and the process gas heater.
- The natural gas stream or reducing gas make-up is mixed with the reducing gas recycle stream from the CO<sub>2</sub> removal system.
- The reducing gas stream is heated to 933°C in the gas heater. Hot reducing gas is fed to the reduction zone at 5.5 kg/cm<sup>3</sup> and flows counter to the solids.
- Off gas from the reactor at about 400°C passes through a quenching/scrubbing system where water produced during reduction is condensed and removed along with most of the dust in the gas.
- Scrubbed gas is fed to the CO<sub>2</sub> removal system by means of the reducing gas recycle compressor.
- Decarbonated reducing gas is mixed with the natural gas stream or reducing gas make-up to close the reducing gas circuit.
- A belt conveyor transports iron ore pellets and/or lump ores to the top of the reduction tower where an automated system of bins and pressure locks receives the

ore at atmospheric pressure in an open bin, pressurizes it in intermediate bins and charges it continuously to the reactor.

- Oxygen is removed from the iron ore in the upper section of the reactor by the reducing gases and the product is then carburized.
- A rotary valve at the outlet of the reactor regulates the continuous flow of the charge through the reactor.
- DRI is removed by automated pressurized bins and pressure locks. In the production of cold DRI, the cooling gas circuit comprises the reactor cooling zone, the cooling gas quenching/scrubbing system and the cooling gas recycle compressor.
- The cooling gas is fed at the lower conical part of the reactor, at roughly 40°C, flowing counter to the descending DRI.
- The gas distribution is uniform throughout, with good contact between the gas and the solid material. The cooling gas leaves the reactor at the upper conical part at about 460°C and is then quenched/scrubbed by means of cooling water.
- Scrubbed cooling gas passes through the cooling gas recycle compressor for recycle to the reactor after being made up with natural gas injected to the cooling gas circuit for optimum efficiency and control of the cooling and carburization processes.
- hot DRI, at 700°C, is discharged continuously from the reactor to the pneumatic transport system. The product is transported by means of a reducing carrier gas to surge bins located above the meltshops for controlled feeding to the electric arc furnace. For the production of HBI, hot DRI, at 700°C, is discharged continuously from the reactor to the hot briquetting machines arranged below.
- The HBI is cooled to about 80° in vibrating cooling conveyors using cooling water, and then discharged to the HBI transport conveyor.

#### ❖ PROCESS ADVANTAGES:

1. Proven equipment performance (uses HYL II and HYL III reactor technology)
2. Raw material flexibility
3. Not sensitive to S in natural gas or ore
4. No reformer – lower Capital costs
5. High-energy efficiency (87% in comparison to 70% for most efficient other DRI plants).
6. Hylsa claims lower overall operating costs (to be confirmed)

## CHAPTER-4: PARAMETERS OF SPONGE IRON MAKING:

- For successful operations the process of DR technology has specified the characteristics of raw materials to be used in the process
- ❖ IRON ORE
- ❖ CHARACTERISTICS OF IRON ORE
- Lumps or pellets have high iron content, low gangue content, and good mechanical strength and are readily reducible and of nondecrepitating variety. Iron ore feed to the reactors has the following characteristics:
  - Chemical composition
  - Reduction properties
  - Physical characteristics
- ❖ Chemical composition.
- The only chemical change in the DRI process is the removal of oxygen from the iron ore in the solid state by reducing gases containing CO and H<sub>2</sub>.
- since sponge iron is in solid state, all impurities in the oxide feed remain as such in the product.

- Therefore, iron content of the ore should be as high as possible preferably 65-68%. The ore containing more than 68% iron may not be of advantage as generation of more fines would occur due to low abrasion resistance.
- High gangue content in the DRI would require additional energy.
- Fluxes and refractories during melting, adversely affect the operation of arc furnace. This also affects productivity of the furnace and the quality of steel produced. Therefore, gangue content of the ore feed should not exceed more than 5%.
- The SiO<sub>2</sub> content of the gangue should not be too low as it results in swelling and decrepitation.
- Alumina being acidic will require extra flux increasing the slag volume in steel making
- The total (SiO<sub>2</sub>+Al<sub>2</sub>O<sub>3</sub>) should not be more than 4%.
- Alkali content of the ore gives rise to swelling which causes degradation and creates operational difficulties.
- Phosphorus has no effect on the DRI. But it is a must for good quality steel. The sulphur content of the ore should be below 0.02% as it plays an important role in DRI process.
- Addition of limestone and dolomite increases the strength of the fired pellets.

#### ❖ PHYSICAL CHARACTERISTICS OF THE ORE SIZE DISTRIBUTION:

- Size of the iron ore pellet is very important for the production of DRI.
- The optimum size is determined by its reducibility characteristics.
- The feed materials for DRI production should have narrow size range as far as possible to get a uniform metallised product.
- In shaft furnace narrow size of feed material is essential for good permeability of the bed.
- Ore fines of the size range of 3-5mm can be processed in the rotary kiln through ore slinging mechanism.
- The mechanical properties like abrasion index of the ore/ pellet and cold compression strength of the pellet are normally specified as for blast furnace feed.
- The ore pellets must have strength greater than 200kg, and abrasion index 600 micron.
- Some ore/ pellets tend to crumble on heating at lower temperature thus, generating fines. This is called decrepitation.

#### ❖ REDUCIBILITY:

- Reducibility of the ore has great influence on the productivity.
- Higher the reducibility lower is the retention time. Therefore the ore must have high reducibility.
- Generally hard dense lump ore and overfired pellets do not show good reducibility.
- Magnetite exhibits poor reducibility as compared to hematite.
- In shaft furnace process, the reducibility should be 90-95% within a residence time of 6 hours in the temperature range of 800-1000°C.

#### ❖ TESTS ON NON COKING COAL:



- The consumption of coal for production of DRI depends on the reaction stoichiometry, fixed carbon content and loss of fixed carbon.
- Therefore, evaluation and selection of coal for the process is very critical and should be done very carefully. In selection of coal following characteristics shall be considered:
  - a. Proximate analysis
  - b. Ash fusion temperature
  - c. Sulphur content
  - d. Caking and swelling index
  - e. Calorific value
  - f. Coal char reactivity
  - g. Char strength
  - h. Sinter fracture load
  - i. Coal size
  - j. Ash chemistry
  - k. Proximate analysis:
    - l. Fixed carbon:
    - m. The fixed carbon aspect of coal is most important aspect of
    - n. proximate analysis.
    - o. Volatile matter

#### ❖ THE VOLATILE MATTER

- contributes to heat as well as helps in reduction of the iron oxide in the kiln.
- Low volatile matter coal shall not provide adequate heat. Very high volatile coal is not preferred as it affects the composition of the DRI.
- Therefore Indian coals containing 25-35% volatile matter at a mean ash value 22% are preferred.

#### ❖ ASH CONTENT:

- The ash content affects the thermal requirement and productivity of the kiln adversely.
- The ash is an inert material occupying the space in the kiln.
- A value of 15% ash is considered to be good. However under Indian conditions the ash content in the coal should not exceed 24%.

#### ❖ MOISTURE:

- The moisture in the coal is in two forms: Free moisture, Combined moisture
- The moisture content increases the thermal load in the kiln.
- The total moisture content should be less than 5%.

#### ❖ ASH FUSION TEMPERATURE:

- The ash fusion temperature of the coal is a very important property of the non-coking coal. This is the temperature where pure coal starts to fuse.
- Ash fusion temperature should be at least 200°C higher than operating temperature of the kiln.
- The coal ash inside the rotary kiln comes in contact with other chemical compounds forming low eutectics promoting accretion formation on the kiln wall.

- This reduces the productivity of the kiln
- ❖ **SULPHUR CONTENT:**
  - Sulphur may be present in coal as organic sulphur in combination with carbon and hydrogen.
  - Sulphur may also be present as FeS and sulphate.
  - The amount of sulphur as sulphate is very less.
  - The organic sulphur is released gradually.
  - The sponge iron in the bed absorbs sulphur as the temperature increases.
  - Sulphur content in the bed increases exponentially.
- ❖ **CAKING AND SWELLING INDEX:**
  - High caking index causes sintering and reduces char reactivity of coal with CO<sub>2</sub>.
  - It also causes accretion build up in the kiln. Therefore a coal of caking index more than 3 is not preferred for DRI.
  - Coal has the property of swelling when it is heated.
  - The coal forms big masses with less density. These agglomerates of low density may disintegrate to generate more fines which may be lost in the kiln.
  - Swelling index of coal should be less than 3.
- ❖ **CALORIFIC VALUE:**
  - The thermal requirement of the process is met by burning coal.
  - The calorific value of the coal increases with increase in carbon content.
  - Low calorific value means high consumption of coal.
- ❖ **CHAR REACTIVITY:**
  - Reactivity of coal char is a measure of the rate of conversion of CO<sub>2</sub> to CO according to Boudouard reaction.
  - The gasification of coal char is complex. It depends on various factors like rank of coal, volatile matter, porosity, specific surface, charring temperature, rate of heating etc., Coals with high reactivity are preferred in the rotary kilns because it is easier to operate at lower temperature.
- ❖ **CHAR STRENGTH:**
  - After removal of moisture and volatile matter, the degradation of char in the kiln depends on char strength. The char strength increases with coal rank.
- ❖ **COAL SIZE:**
  - The size of coal should be such that it should mix well with the charge.
  - The size of the coal should not be very fine otherwise it causes carbon loss. The proportion of -1mm size should not be more than 5-10%.

## **Chapter-7: Environmental Management in DRI Plants:**

- Sponge iron units are highly air polluting industries. They also generate huge amount of solid waste as char from the process and fine dust retained in the air pollution control devices.
- The hot flue gas which flows in counter current direction of the materials inside the rotary kiln finally passes through ABC (After Burning Chamber) where residual carbon or CO is burnt by the excess air available at high temperature at about 1000OC.
- The heavier dust particles settle in dust settling chamber and the flue gas containing high quantity of fine dust particles (P.M. –30gm/Nm<sup>3</sup>) is released to the atmosphere at a temperature of 900OC in the form of dense fume through a chimney. If no pollution control device is installed, it becomes a major source of air pollution, which is responsible for dust pollution in the surrounding area.
- Most of the fugitive dust and source emission from sponge iron process are invisible micro fine respirable particulate matter which causes varieties of human ailments like respiratory ailments leading to loss in work efficiency.
- Air Pollution is one of the biggest hazards from Sponge Iron plants where fine coal dust and fugitive emissions will play a vital role in damaging plants

and health of the inhabitants if properly not controlled

❖ **AIR POLLUTION POINT SOURCES**

1. Kiln Flue Gases after ABC ( Control equipment ESPs / Bag Filters/ Wet
2. Scrubbers)
3. Emergency Stack / Safety Cap above the ABC to maintain positive
4. pressure inside kiln and avoid CO related explosions
5. Cooler Discharge
6. Product House
7. Iron Ore and Coal Crushing

❖ **FUGITIVE EMISSIONS SOURCES**

1. Raw material handling yard ( Unloading, stacking, reclaiming operations)
2. Product discharge system (Cooler discharge conveyers transfer points,
3. junction house, screens, magnetic separators, storage silo, truck loading
4. and parking operations- Control equipment of water sprinklers, bag filters,
5. covered product house, covered conveyor belt).
6. The source of fugitive emissions and their control measures are given
7. Below

<b>Sl.No</b>	<b>Sources of fugitive dust emission</b>	<b>Control measures prescribed</b>
1.	Raw material handling & preparation area	Automised water spraying system. Work zone should be concreted
2.	Crushing and screening of coal (Coal circuit)	Pulse jet Bag Filter & automised water spraying nozzles
3.	Crushing and screening of iron ore (Iron ore circuit)	Pulse jet Bag Filter & automised water spraying nozzles
4.	All material transfer points and conveyor belt	Enclosures and Pulse jet Bag Filter
5.	Discharge points of Raw material storage bins	Pulse jet Bag Filter
6.	Raw material feeding point into kiln	Pulse jet Bag Filter
7.	Coal injection point into kiln	Pulse jet Bag Filter with recycling

		of coal fines back into the coal injection system
8.	Leakage from slip rings of the rotary kiln	Realignment of the kiln and changing of seal/ packing materials during shutdown period
9.	Cooler discharge circuit	Pulse jet Bag Filter
10.	Intermediate bins in between cooler discharge area and product separation unit	Pulse jet Bag Filter
11.	Product separation unit	Pulse jet Bag Filter
12.	Wind blown dust from solid waste dump yard	Provision of boundary wall around the dump yard, covering by earth and automatised water spraying on the dump area by rotating nozzles

- Even after installation all pollution control devices in the plant, the ambient air quality with regard to SPM and RSPM, do not meet the standard many times due to the following reasons:
  1. Bad house keeping,
  2. Internal and approach roads not black topped/ concreted, work zone not concreted. Loose dust periodically not removed from roads, which become airborne.
  3. Unloading of raw materials, loading of chars and fined carelessly.
  4. Trucks not covered and there is spillage of materials on the road during transportation.
  5. Fine loose dust form the work zone and raw material and solid waste dump yards become wind borne during stormy weather.
  6. Leakage of flue gas through kiln cap in between power failure and start up of D.G.
  7. Bad maintenance and malfunctioning of ESP/ Bag Filters/ dust handling systems.
  8. Inadequate water sprinkling.
  9. ESP/ BF dust handling system not mechanized. Dust collection points under the hoppers properly not enclosed.
  10. Most of the sponge iron industries do not have dedicated team for proper house keeping and attending to pollution problems

#### ❖ SOLID WASTE GENERATION

- Char & Dolo Char
- Flue Dust,
- GCT /GCP Plant sludge
- Fly Ash and
- Kiln accretions

#### ❖ CHAR & DOLA CHAR STORAGE SHED:

- The Production of Char & Dola Char will be 40% of the total production of Sponge Iron and this is easily salable to Brick Kilns, and power generation units.

- Maintain less stones and not to allow the material exposed to water.
- Cost of the shed is Rs.30 lakhs.
- Pay back period one to two years
- Quantity of dust collected per day is 40 tons and sold at Rs.200/- per ton.
- ❖ **CLEANER PRODUCTION OPTIONS FOR SPONGE IRON INDUSTRY**

#### **Selection of Quality Raw Materials:**

- The quality of raw materials selected will effect quality of the product at the same time will determine the amount of pollution load generated and wastes generation. Hence the higher grade of raw materials (Iron ore, Coal and Dolomite) may be selected for better yields of Sponge Iron production.

#### **Waste Heat Recovery:**

- Pre-heating system can be provided for raw material feed for units having production capacity of 50 TPD and 100 TPD to recover the waste heat from kiln flue gases. One such unit has already been in operation at Bellary, Karnataka.
- The following are the benefits of preheating system:
  1. The cost of production as compared without pre-heater is low.
  2. As the preheating system is provided which will ensure reduction of coal consumption in the preheating zone of the kiln and for the material may consume less time to reach in the reduction zone, this may enhance production.
  3. The unburnt carbon particles, volatiles, dust and left over carbon monoxide will be burnt in presence of excess air in the pre-heater, their by reducing the emission levels substantially.
  4. The consumption of water will be substantially reduced in the GCT due to low flue gas temperature

#### **CO-GENERATION:**

- Sponge Iron plants of 2X100 TPD / 3X100 TPD and more capacities with FBC boiler will give consistency in power generation which can be used for production of steel as a downstream facility to make the project economically viable. This will not only help in gaining carbon credits for more financial gains but also ensures continuous power supply for plant operation.

#### **AUTOMISATION / OPTIMISATION OF PROCESS:**

- Entire process may be automated through Programmed Logic Control (PLC) to eliminate human errors causing pollution and affecting the quality of the product. The opening and closing of the cap of bypass stack shall be electronically recorded with time and duration. Interlocking facility should be provided between ESP operation and raw material feeding.

#### **SOLID WASTE MANAGEMENT:**

- The various types of solid waste generated in the process can be used as a raw material for making use as detailed below
  1. Coal fines collected in the coal crushing dedusting system can be mixed with char fines and made into briquettes which can be used as a fuel in any system.
  2. Maximum utilization of solid waste like Char and Dolchar, for brick making, cement making should be taken up.

3. Fly ash collected from the waste gas cleaning system (ABC, GCT & ESP) can be used for making fly ash bricks.
4. Bag filter dust collected in the product circuit can also be used as activated carbon in edible oil refineries.
5. Kiln accretions and slag may be used in filling the low lying areas, abandoned mines and for road making.

❖ **ENVIRONMENTAL STANDARDS AND CODE OF PRACTICE FOR POLLUTION PREVENTION FOR SPONGE IRON PLANTS AS PROPOSED BY CPCB.**

- CPCB has proposed environmental standard and Code of Practice for Pollution Prevention for Sponge Iron Plants comprising of Stack Emission Standards, Stack Emission Standards from de-dusting units and Fugitive Emission Standards Code of Practice for Pollution Prevention for
  - Raw Material handling and Preparation
  - Cooler Discharge and Product Separation Unit, Effluent Discharge Standards,
  - Noise Levels Standards and Solid Waste Management.

**CHAPTER 8 PRODUCTION OF FERRO ALLOY:**

- **Ferroalloy** refers to various alloys of iron with a high proportion of one or more other elements such as manganese (Mn), aluminium (Al), or silicon (Si). They are used in the production of steels and alloys. The alloys impart distinctive qualities to steel and cast iron or serve important functions during production and are, therefore, closely associated with the iron and steel industry,

**DIFFERENT FERROALLOYS :**

- the main ferroalloys are
  - FeAl – ferroaluminum
  - FeB – ferroboron
  - FeCe – ferrocerium
  - FeCr – ferrochromium
  - FeMg – ferromagnesium
  - FeMn – ferromanganese
  - FeMo – ferromolybdenum
  - FeNb – ferroniobium

- FeNi – ferronickel
- FeP – ferrophosphorus
- FeSi – ferrosilicon
- FeSiMg – ferrosilicon magnesium
- FeTi – ferrotitanium
- FeU – ferrouanium
- FeV – ferrovanadium
- FeW – ferrotungsten
- Ferro alloys production can be divided into 3 groups depending on the reduction process namely
  1. Carbothermic
  2. Silicothermic
  3. Aluminothermic

### 1. CARBOTHERMIC REDUCTION.

- More commonly, ferroalloys are produced by carbothermic reactions, involving reduction of oxides with carbon (as coke) in the presence of iron. Some ferroalloys are produced by the addition of elements into molten iron.
- Carbothermic processes are mainly used for the large scale production of ferrosilicon, ferromanganese, ferrochromium, ferronickel and ferrotungsten.
- Carbothermic processes for the production of ferroboron, ferrotitanium, ferrovanadium, and ferromolybdenum have been largely replaced by metallothermic processes, mainly aluminothermic and silicothermic.
- Ore are smelted along with the reductant like coke in a submerged electric furnace where reduction of oxide with carbon takes place resulting the formation of alloy and slag.

### 2. SILICOTHERMIC REDUCTION PROCESS:

- This process is chosen for the production of low carbon alloys.
- Here silicon is used as reductant in the form of silico chrome for chrome alloys and silicomanganese for manganese alloys
- The reaction are highly exothermic with generation of a lot of heat. hence refractory control is more important
- There are two different method. in one method calcined lime and preheated ore are melted together in an open ac furnace and the ore lime melt is allowed to react with silico chrome in the ladle outside.
- In the second method ore, lime and the reductant fed in an open arc furnace and after the reaction complete metal and slag are tapped.
- Extra low carbon alloy can be produced by this method

### 3. ALUMINOTHERMIC REDUCTION PROCESS:

- This method is used for small scale production of low and medium carbon alloys.



- Pure metallic aluminium is used as a reductant for reducing the oxide of chrome or manganese ore.
- The reactions are carried out in a thermit vessel and the ground raw material are fed after through mixing and preheated in the vessel.
- An ignition mixture is given for initiating the reactions.
- Low carbon ferrochrome, ferromanganese and all noble alloys are produced by this method.

#### FERROSILLICON(FeSi);

- **Ferrosilicon** is an alloy of iron and silicon with an average silicon content between 15 and 90 weight percent.
- The ferro-alloy normally contains Si in the range of 15 % to 90 %. The remainder is Fe, with around 2 % of other elements like aluminum (Al) and calcium (Ca).
- Fe-Si is produced industrially by carbo-thermic reduction of silicon dioxide (SiO<sub>2</sub>) with carbon (C) in the presence of iron ore, scrap iron, mill scale, or other source of iron.
- The smelting of Fe-Si is a continuous process carried out in the electric submerged arc furnace (SAF) with the self-baking electrodes.

#### RAW MATERIAL:

- Quartz
- coke or charcoal
- iron ore or steelscrap.

#### PRODUCTION OF FERROSILICON:

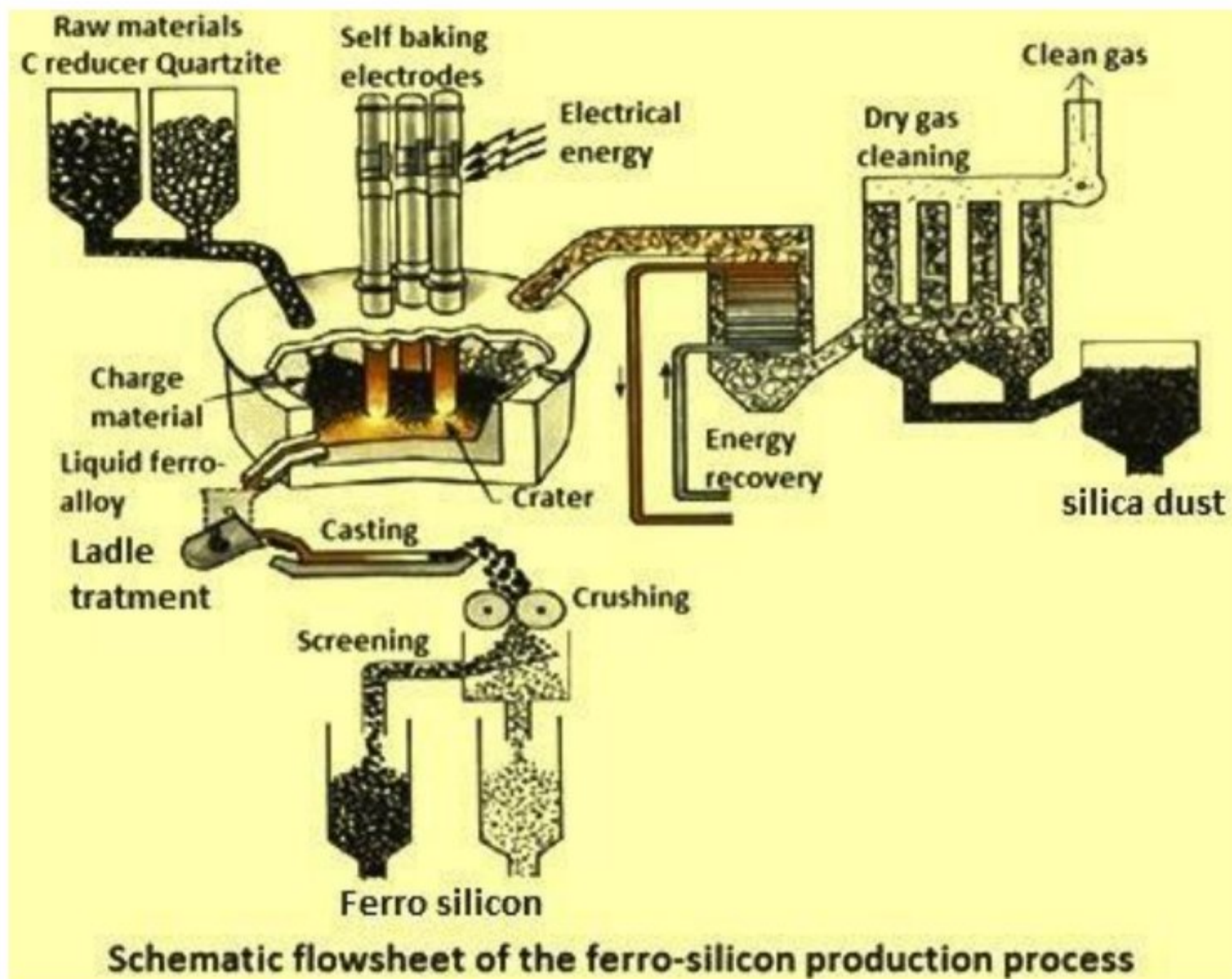

- Iron ore ( $\text{Fe}_2\text{O}_3$ ), quartz ( $\text{SiO}_2$ ) and carbon (C), in the form of coal, coke and biocarbon, is added at the top of the furnace.
- Three electrodes in the furnace is heating the material. At approximately  $2000^\circ\text{C}$  the carbon reacts with the oxygen in the quartz and we are left with liquid silicon.
- The iron oxide in the iron ore pellets reacts with the carbon through a similar reaction and forms pure iron. Melted iron and silicon mix and is then tapped in ladles.
- Reactions in the furnace occur according to the simplified scheme:
  - $\text{SiO}_2 + 2\text{C} \rightarrow \text{Si} + 2\text{CO}$
  - $\text{Fe} + \text{Si} \rightarrow \text{FeSi}$
- Side reactions also occur that result in a lower yield of the desired product, especially when insufficient carbon is used:
  - $\text{SiO}_2 + \text{C} \rightarrow \text{SiO} + \text{CO}$
  - $\text{SiO}_2 + \text{Si} \rightarrow 2\text{SiO}$
- Gaseous SiO is oxidized by atmospheric oxygen at the burden surface to give  $\text{SiO}_2$  dust, which is carried out of the furnace with off-gas.
- Ferrosilicon production is a slag-free process, which means that all the impurities present in the raw materials are transferred to the product. To obtain high purities the alloy must be purified by further treatment outside the furnace.

## FERROMANGANESE

- Ferro-manganese (Fe-Mn) is an important additive used as a deoxidizer in the production of steel.
- It is a master alloy of iron (Fe) and manganese (Mn) with a minimum Mn content of 65 %, and maximum Mn content of 95 %.
- It is produced by heating a mixture of the oxides of Mn ( $MnO_2$ ) and iron ( $Fe_2O_3$ ) with carbon (C) normally as coke or coal.
- There are several grades of Fe-Mn which are divided into many groups. The three main groups are
  - high C Fe-Mn,
  - medium C Fe-Mn,
  - low C Fe-Mn.
- High Carbon Fe-Mn can be made in BF and in SAF.

### RAW MATERIAL:

- The raw materials required for the production of high –carbon ferromanganese are
  - manganese ores
  - Fluxes such as limestone, dolomite, or silica
  - Coke
  - Iron ore

### PRODUCTION OF FERROMANGANESE IN BLAST FURNACES

- Ferromanganese can be produced in blast furnaces in a manner similar to pig iron; however in the western world only four producers employ this method.
- These are Thyssen Stahl (Germany), BSC Cleveland (United Kingdom), SFPO (France) and Mizushima (Japan). The choice of the use of blast furnaces over electric furnaces is based on the relative price of coke and electricity. The product produced from blast furnaces generally contains 76% Mn and 16% Fe.

### RAW MATERIAL SELECTION AND PRETREATMENT.

- The raw materials required for the production of high –carbon ferromanganese are manganese ores, Fluxes such as limestone, dolomite, or silica, and solid fuels and reductants such as coke.
- In order to produce ferromanganese of the required grade a single ore is seldom suitable because the desired Mn/Fe ratio of the charge determines the Mn content of the final product. Ores from various sources are therefore blended to achieve the ideal ratio and to limit the contents of the deleterious components silica, alumina, and phosphorus in the raw material mix.
- The raw material is crushed and screened to 5-30mm. Alternatively, sintered or pelletized fine ore can be used. Some deleterious components can be partially removed from the ore prior to melting by dense –medium separation or flotation. Slagging components can be added to the sintered or pelletized ore, which results in cost savings in the blast furnaces.

### BLAST FURNACE OPERATION.

- In comparison to iron making ,high gas temperatures are required in ferromanganese production because of manganese(II)oxide takes place at a higher temperature than is required for the reduction of wustite.
- This is achieved by oxygen enrichment of the hot blast or ,in the case of SFPO,by heating the blast with non transferred arc plasma torches. The plasma arc increases the flame temperature from 2200°to2800°C and considerably reduces the coke consumption, which usually ranges from 1270 to 2000kg/t.
- The recovery of manganese in the alloy is usually 75-85%.This is influenced by the MnO content ofthe slag ,the slag to metal ratio,and losses in the flue gases.
- The MnO content of theslag is highly dependent on the basicity ratio(CaO+MgO)/SiO2

### THE REDUCTION PROCESS IN THE BLAST FURNACE .

- The reduction of the higher manganese oxides to manganese (II) oxide takes place in the upper zone of the shaft .These generally occur below 900°Cand are indirect.The reactions are exothermic,and the heat generated causes high top temperatures and necessitates water cooling of the furnace top.
- The reduction of manganese(II) oxide;  
 $MnO + C \rightarrow Mn + CO$
- is highly endothermic,in contrast to the weakly endothermic reduction of wustite.This requires higher temperatures and, consequently,higher coke rates are required for the smelting of ferromanganese in blast furnaces.

### PRODUCTION OF HIGH CARBON FERROMANGANESE IN ELECTRIC ARC FURNACES:

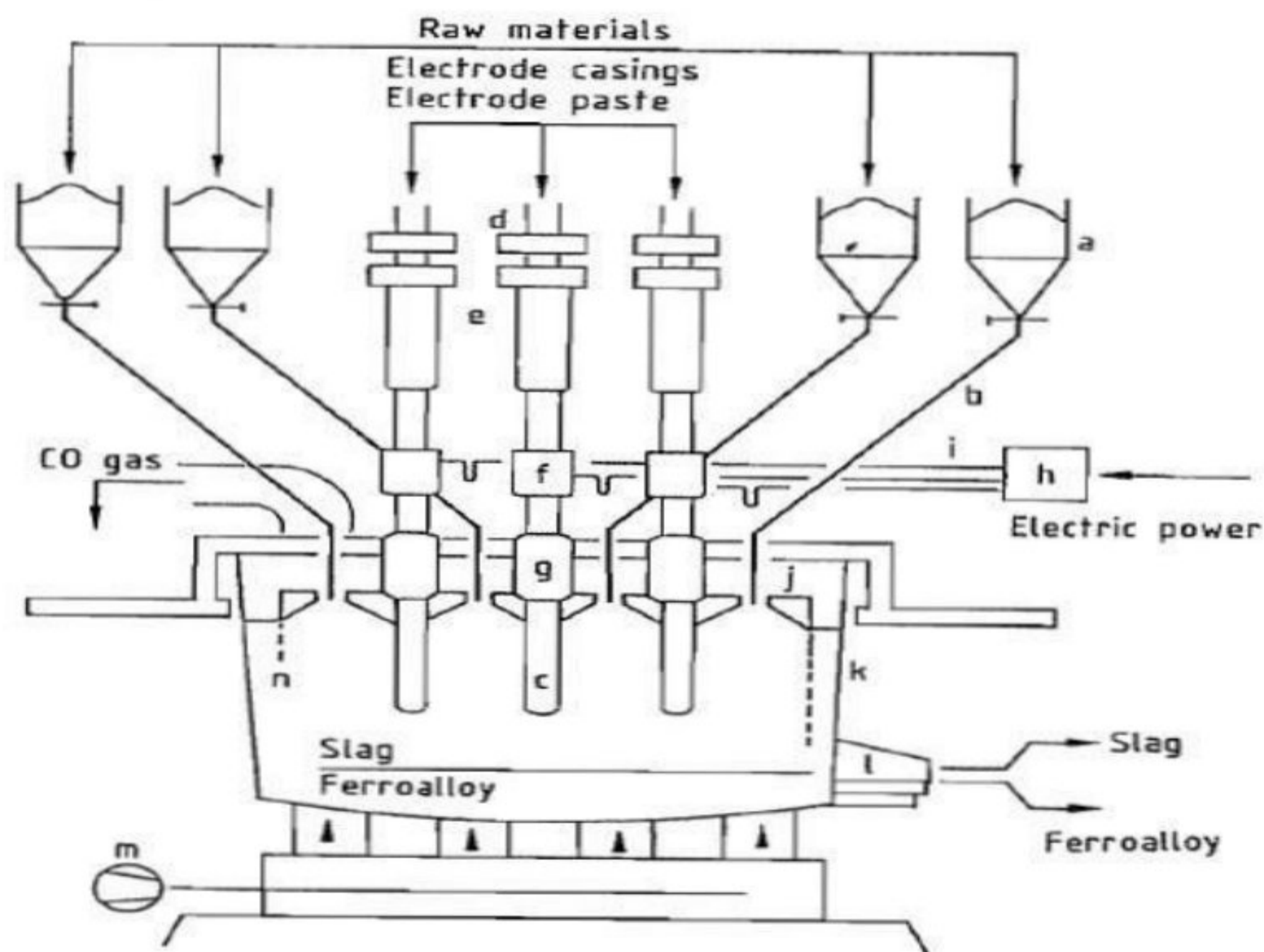

Layout of an electric arc furnace:a)Charging bins,b)Charging tubes,c)Electrodes,d)Electodes,d)Electrode slipping device,e)Electrode positioning devices,f)Current

transmission to electrodes,g)Electodes sealing,h)Furnace transformer,i)Current bus bar system,j)furnace cover,k)furnace shell,l)tap hole,m) furnace bottom cooling,n) refractory material

- The material descends rapidly down the side of the electrode into the semi-active zone where prereduction of higher manganese oxides to MnO takes place. Thereafter, the material moves into the active zones of the furnace where reactions take place between the manganese oxide in the melt and the coke particles in the coke bed:
- $7\text{MnO} + 10\text{C} \rightarrow \text{Mn}_7\text{C}_3 + 7\text{CO}$
- Equilibrium between the slag and metal was thought to exist under each electrode, and further from the electrode, layers of unreacted ore and coke were found to be present.
- This suggests that heat is concentrated under each electrode. The path of electrical transfer was deduced to be from the electrode tip through the coke bed and into the alloy layer
- The efficient production of high-carbon ferromanganese therefore depends on the degree of the reduction of MnO by carbon as well as the prereduction that occurs in the upper region of the furnace
- The ratio of CO and CO<sub>2</sub> in the off-gas is important and can be used to monitor the condition of the furnace. The higher the CO<sub>2</sub> content of the off-gas, the higher is the energy efficiency of the process, because the reducing potential of the gas is being more fully utilized.
- Good operation of the furnace is indicated by a CO<sub>2</sub>/(CO<sub>2</sub>+CO) ratio of 0.55. This ratio, as well as the MnO content of the slag, can be used to control the coke rate of the furnace. Undercoking of the furnace is indicated by high MnO content of the slag and a low CO<sub>2</sub> content in the off-gas.

## FERROCHROMIUM

- Ferrochromium is a master alloy of iron and chromium, containing 45-95% Cr and various amounts of iron, carbon, and other elements. The ferrochromium alloys are classified by their carbon content;
- 1. High-carbon ferrochromium with 4-10 % C
- 2. Medium-carbon ferrochromium with 0,5-4% C
- 3. Low-carbon ferrochromium with 0,01-0,5% C
- The mechanical and chemical properties of steel can be improved by alloying it with ferrochromium. Chromium combined with nickel gives stainless steel excellent chemical resistance.

## RAW MATERIALS

- The only raw materials for the production of ferrochromium are chromite ores. The mineral chromite has spinel structure and its formula may be written as  $(\text{Fe}^{2+}, \text{Mg})\text{O} \cdot (\text{Cr}, \text{Al}, \text{Fe}^{3+})_2\text{O}_3$ .
- A high Cr:Fe ratio is advantageous to produce an alloy with high chromium content. In the production of high-carbon ferrochromium, which is by far the alloy in greatest demand, generally a lumpy type of chromite ore is necessary. The submerged arc smelting of high-carbon ferrochromium by the direct reduction of carbon in large

low-shaft electric furnaces generally requires lumpy chromite ores to allow the reaction zone to the top the furnaces where the burden is continuously charged.

- The reducing agent for chromite is usually carbon in the form of coke; its contents of S and P should be low. Silicon as a reducing agent is used in the form of ferrosilicochromium or ferrosilicon to produce low-carbon ferrochromium. Fluxing agents, e.g. quartzite or alumina and lime, are charged with the burden for slag formation. In the carbothermic production of ferrosilicochromium, chromite and quartzite are used as the raw materials

## PRODUCTION

- The oxides of iron and chromium present in the chromite can be readily reduced at high temperature with carbon. Because of the tendency of chromium to form carbides, a carbon containing alloy is obtained.
- The oxides can also be reduced with silicon, aluminum, or magnesium. However, only carbothermic and silicothermic reductions are used commercially. The reducibility of chromite depends on its composition.
- A chromite rich in iron ( $\text{FeO} \cdot \text{Cr}_2\text{O}_3$ ) can be reduced by carbon at lower temperature than ore rich in magnesium ( $\text{MgO} \cdot \text{Cr}_2\text{O}_3$ ). Carbides with higher carbon content formed initially at lower temperature react at higher temperature with  $\text{Cr}_2\text{O}_3$  and form carbides with lower carbon content; finally, reduction of  $\text{SiO}_2$  starts at higher temperature
- Therefore, production of ferrosilico-chromium alloys requires high temperature.
- In practice the reactions are somewhat more complicated because iron-containing chromium carbides are formed. In high-carbon ferrochromium, the double carbide  $(\text{Cr,Fe})_7\text{C}_3$  is present. In this compound, two to four Cr atoms can be substituted by iron atoms.
- $\text{FeO} \cdot \text{Cr}_2\text{O}_3 + \text{C} \rightarrow \text{Fe} + \text{Cr}_2\text{O}_3 + \text{CO}$   $t=950^\circ\text{C}$
- For the  $\text{Cr}_2\text{O}_3$  reduction:
- $\text{MgO} \cdot \text{Cr}_2\text{O}_3 + 13/3\text{C} \rightarrow 2/3\text{Cr}_2\text{C}_3 + \text{MgO} + 3\text{CO}$   $t=1200^\circ\text{C}$
- Because the difference in temperature between these two reactions is slight and because iron also facilitates reduction of chromium oxide, selective reduction of iron is difficult.
- In carbothermic reduction process, unreduced oxides from the chromite ( $\text{MgO}$ ,  $\text{Al}_2\text{O}_3$ ) and from the gangue are collected in a slag, which generally contains 30%  $\text{SiO}_2$ , 30%  $\text{MgO}$  and 30%  $\text{Al}_2\text{O}_3$ . The remaining 10% is composed of  $\text{Cr}_2\text{O}_3$ ,  $\text{CaO}$ ,  $\text{MnO}$ , and  $\text{FeO}$ . Control of slag composition is important with respect to melting temperature and fluidity.
- Low-carbon ferrochromium is produced by the silicothermic reduction of chromite ore. Silicon is used in the form of ferrosilicochromium, which is produced in submerged arc furnaces by carbon reduction of chromite ore and quartzite. The solubility of carbon in the  $\text{FeSiCr}$  alloy depends on the silicon content; if the silicon content is higher, the carbon content is lower.
- The reduction of  $\text{Cr}_2\text{O}_3$  by Si is enhanced by addition of lime ( $\text{CaO}$ ), which reduces the activity of  $\text{SiO}_2$  in the slag. The reduction may be written as follows:
- $\text{FeO} \cdot \text{Cr}_2\text{O}_3 + 2\text{Si} + 4\text{CaO} \rightarrow (2\text{Cr} + \text{Fe}) + 2\text{Ca}_2\text{SiO}_4$

## FERRONICKEL

- The rotary kiln electric furnace smelting process is now used almost universally for the production of ferronickel from oxide ores.

### ROTARY KILN-ELECTRIC FURNACE PROCESS

- In the electric furnace the calcined ore was smelted with reductant to form immiscible layers of slag and ferronickel.
- The New Caledonian ores, with their high magnesia and silica contents (2.5%Ni, 10-15%Fe), require no additional flux for slag formation.
- Virtually all the nickel and 60-70% of the iron in the ore are reduced to metal to yield a ferronickel grading about 20%Ni; the slag contains only 0.1%Ni.
- The degree of reduction achieved in the kiln depends on the composition of the ore and on the reactivity of the reductant. Iron and nickel silicate minerals are generally less reactive than nickel oxide minerals.
- Usually lignites and charcoal are the most reactive reductants, and high volatile coals are more reactive than low-volatile coals, anthracite, or coke.
- Typically, under optimum conditions, up to 40% of the nickel is reduced to metal in the kiln, while the iron oxides are reduced to iron(II) oxide (FeO).
- In the electric furnace the charge must be heated to 1400-1650°C to permit the separation of distinct slag and metal phases.
- Operation of the electric furnace is simplest when the slag melting temperature is higher than the metal melting temperature (1300-1400°C). For such a system the furnace is operated with a covered bath.
- The hot ore charge is allowed to build up on top of the molten slag, and the electrodes are not immersed in the slag layer. Under these conditions much of the reduction reaction occurs in the hot charge layer before it melts.

(A)

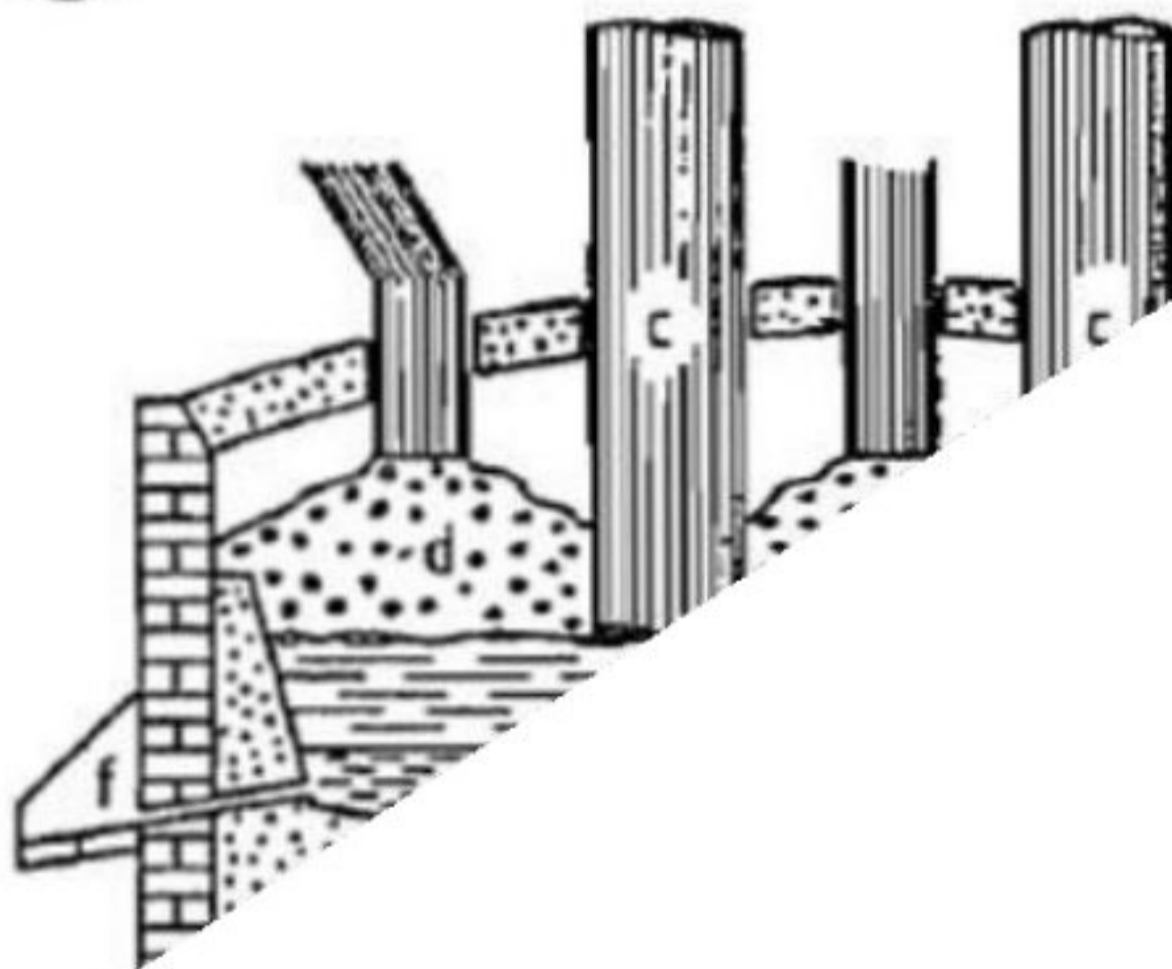

- The high-iron limonite ores, which produce slags with melting points well below the melting point of the metal phase, can be smelted if the distance between the

electrode tips and the slag-metal interface is reduced significantly. The electrodes must therefore penetrate deeply into the molten slag layer

### UGINE FERRONICKEL PROCESS

- In the rotary kiln-electric furnace process excess carbon is normally added to the furnace charge to ensure quantitative reduction of nickel oxide. As a result more iron oxide is reduced to metal than is desirable, decreasing the ferronickel grade and leaving a high residual carbon level, typically 1-3% in the product.
- In the Uginex Process the ore is dried and calcined in a rotary kiln and melted in an electric furnace without addition of reductant to produce a melt of iron and nickel oxides.
- No slag separation occurs in the electric furnace. The molten ore is transferred to a ladle furnace where it is reduced by reaction with ferrosilicon at 1650°C. The two phases are mixed by repeated pouring of the mixture from one ladle furnace to another.
- The nickel oxide and some of the iron oxide are reduced to metal. The balance of the iron is removed as slag.
  - $2\text{Fe}_2\text{O}_3 + \text{FeSi} \rightarrow 4\text{FeO} + \text{SiO}_2 + \text{Fe}$
  - $2\text{NiO} + \text{FeSi} \rightarrow 2\text{Ni} + \text{SiO}_2 + \text{Fe}$
  - $2\text{FeO} + \text{FeSi} \rightarrow 3\text{Fe} + \text{SiO}_2$
- The reduced ferronickel contains 30-50% Ni and very low levels of carbon and sulfur.
- The majority impurity is phosphorus.

### FALCONDO FERRONICKEL PROCESS

- The Ore is carefully blended to maintain a constant chemical composition, particle size, and moisture content, so that it can be briquetted without a binder.
- The briquettes are calcined and reduced in twelve open-top shaft furnaces.
- The hot reducing gas at 1250°C is first cooled to 1150°C before being supplied to the shaft furnace through the primary tuyeres.
- The gas flows upwards, countercurrent to the ore briquettes which are fed to the open top of the furnace.
- The gas reduces the nickel oxides to metal and the iron oxides to FeO.
- The hot reduced briquettes are discharged from the bottom of the shaft furnace at 880°C and are transferred to one of three electric furnaces. The crude ferronickel, which is tapped at 1475-1500°C, contains 32-40% Ni.
- The slag, containing about 0.15% Ni, is tapped at 1500-1600°C. The crude ferronickel, which typically contains only 0.15% S, 0.03% P, 0.04% Si, and 0.02% C, is refined to remove sulfur and phosphorus.

### REFINING OF FERRONICKEL

- Crude ferronickel produced by the conventional rotary kiln-electric furnace process usually contains high levels of carbon and sulfur.
- Sulfur is generally removed under reducing conditions by adding soda ash, lime, or calcium carbide to the molten ferronickel. Sulfur reacts with the fluxes to form sodium or calcium sulfides, which are slagged off with the silicates formed by reaction of flux with silicon;
  - $3\text{Na}_2\text{O} + 2\text{S} + \text{Si} \rightarrow 2\text{Na}_2\text{S} + \text{Na}_2\text{SiO}_3$
  - $\text{CaC}_2 + \text{S} \rightarrow \text{CaS} + 2\text{C}$



- Removal of silicon, carbon, and phosphorus is normally conducted in an oxygen-blown converter or an oxygen lanced ladle. Phosphorus is oxidized either by blowing the melt with oxygen or by adding iron ore and fluxing the phosphorus(V) oxide with lime:

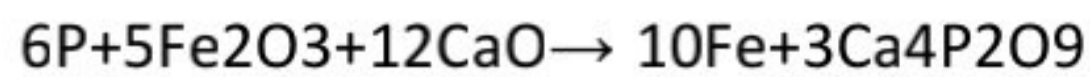

- The slags are removed by skimming after each refining step.

#### ❖ FERROTUNGSTEN

#### ❖ COMPOSITION

- Commercial ferrotungsten is a tungsten-iron alloy containing at least 75%W, and having a very fine grained structure and a steel-gray appearance.

#### ❖ PRODUCTION

- The raw materials used for ferrotungsten production are rich ores or concentrates containing the minerals wolframite, hubnerite, ferberite, and scheelite.
- Ferrotungsten can be produced by carbothermic reduction in an electric arc furnace or by metallothermic reduction aluminum.
- The carbothermic or silicocarbothermic method is preferred for cost reasons.

#### ❖ CARBOTHERMIC PRODUCTION

- Because of the high melting point of ferrotungsten, the so-called solid block melting process is normally used, as tapping off is not possible at the furnace temperatures that are required.
- In this process, the ferrotungsten accumulates in the hearth of the furnace vessel, which is constructed in sections. After the desired weight has been produced, the furnace lining is removed and the metal ingot can be removed after cooling.
- The solid block is cleaned, crushed, and sorted

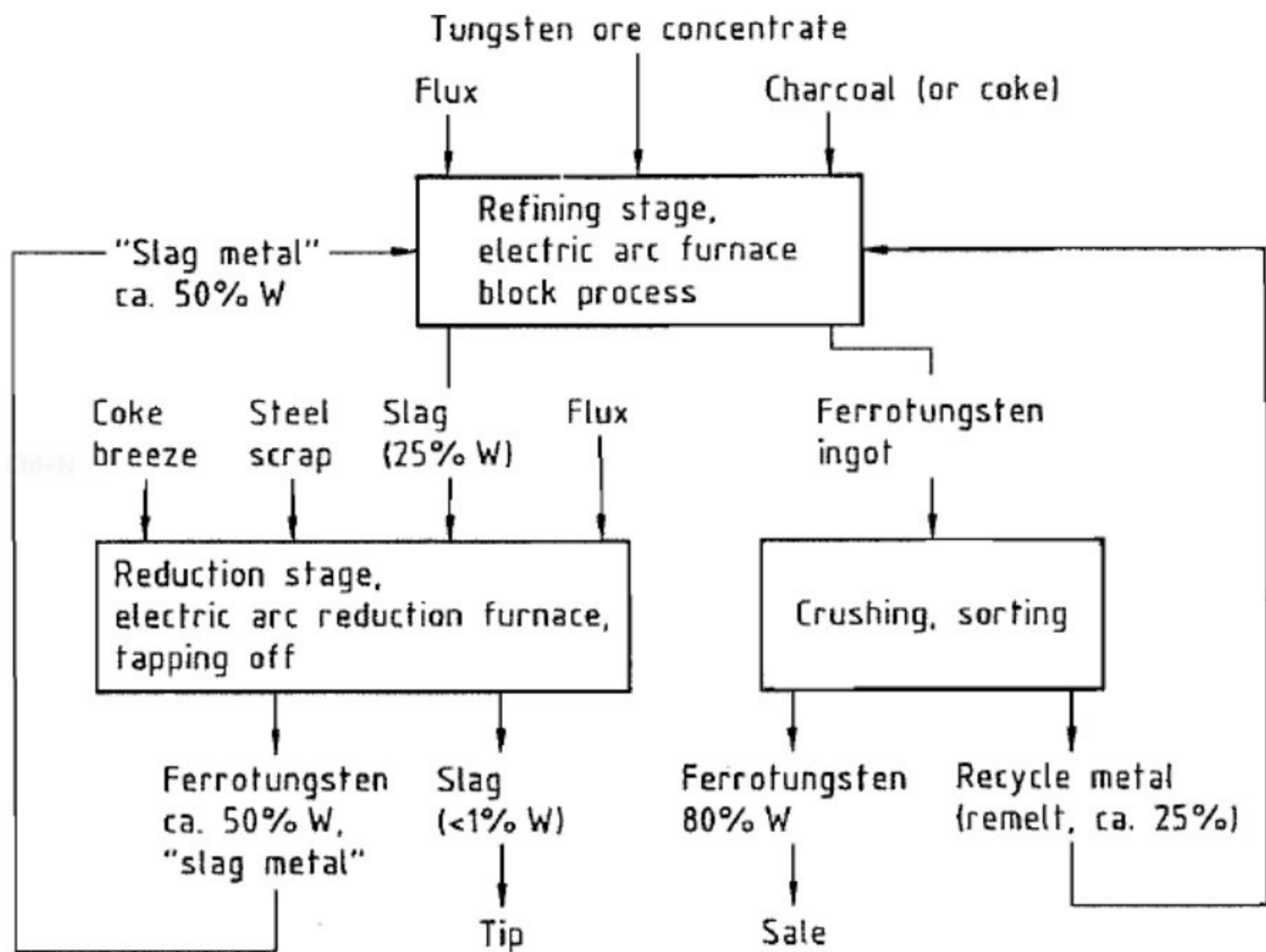

Carbothermic production of ferrotungsten

### CARBOTHERMIC AND SILICOTHERMIC PRODUCTION

- This process is carried out in three successive stages in a three-phase electric arc furnace lined with magnesite. Of the oxygen in the  $WO_3$ , 60% reacts with carbon and 40% with silicon.
- In the first stage, ferrotungsten is produced by substoichiometric carbon reduction. This ferrotungsten is formed in a pasty consistency under a  $WO_3$ -rich slag, and can be scooped out with ladles. Details of the individual processes are as follows:
  - **Stage1:** reduction of tungsten ore concentrates by carbon under a  $WO_3$ -rich slag and scooping out the ferrotungsten
  - **Stage2:** Reduction of the  $WO_3$ -rich slag with  $FeSi75$  and addition of scrap iron. Tapping off the low-  $WO_3$  slag. The metal, with reduced tungsten content remains in the furnace.
  - **Stage3:** refining of the low-tungsten metal by adding tungsten concentrates. A  $WO_3$ -rich refining slag is formed, and the tungsten content of the metal increases.
- The advantages of the process is the continuous method of operation; thus the furnace can be operated for considerably longer periods without interruption for relining than in the solid block process.

## METALLOTHERMIC PRODUCTION

- Tungsten oxide can be reduced by silicon and/or aluminum. Compared with carbothermic reduction, metallothermic production of ferrotungsten requires purer raw materials, as the reactions proceed very rapidly, and the impurities are chemically reduced as well as the raw materials.
- The tungsten concentrates in finely divided form are mixed with coarsely powdered aluminum and silicon. Pure silicon or ferrosilicon cannot be used, as these would not give a self-sustaining reaction, the heat evolved being insufficient to melt the ferrotungsten and slag formed. Aluminum and silicon in the ratio 70:30 are therefore used.
- The reaction mixture is charged into a refractory-lined furnace vessel and preheated to 400-500°C.
- The reaction is started at the top by igniting initiators, which are mixtures of BaO<sub>2</sub> and aluminum powder. A purely aluminothermic mixture burns completely in a few minutes, but silicothermic-aluminothermic mixtures react more slowly. After cooling, the furnace vessel is removed, and the blocks of metal and slag separated. This method produces ferrotungsten ingots of 700-2000 kg.
- The metal ingot is cleaned, crushed, and sorted. Pieces with adhering slag are sent back for remelting.
- The metallothermic production process has lost much of its importance in recent years, owing to the high costs of the aluminum and silicon reducing agents, and the necessity for using pure and therefore expensive raw materials.
- Advantages of the process include the simple, low-cost plant, and the minimal tying-up of materials resulting from the short processing time.
- The tungsten yield is 96%

## ❖ FERROBORON

- Ferroboration is basically an iron-boron alloy containing 10-20%B. It is used mainly in the steel industry.
- Ferroboration was first produced in 1893, by HENRI MOISSAN, from boric acid, iron, and carbon in a single phase electric-arc furnace lined with carbon.
- The introduction of the thermite reaction by GOLDSCHMIDT in 1898 led to the aluminothermic reduction of boric oxide to ferroboration, for years the main commercial method for producing ferroboration. Recently though the carbothermic process has again found use for the production of ferroboration.

## RAW MATERIALS

- The following boron minerals can be used for the manufacture of ferroboration:
  - Colemanite (51% B<sub>2</sub>O<sub>3</sub>),
  - pandermite (48% B<sub>2</sub>O<sub>3</sub>),
  - priceite (51% B<sub>2</sub>O<sub>3</sub>), and
  - boracite (62% B<sub>2</sub>O<sub>3</sub>). However, the raw materials most commonly used are boric oxide (=99% B<sub>2</sub>O<sub>3</sub>) and boric acid (=57% B<sub>2</sub>O<sub>3</sub>)

## PRODUCTION

- Boric oxide can be reduced by carbon, aluminum, or magnesium.

- Reduction by silicon is incomplete. For commercial production, either reduction by carbon (carbothermic or endothermic) or reduction by aluminum, sometimes with some magnesium (aluminothermic or exothermic) is usual.

#### CARBOTHERMIC PRODUCTION

- In order to produce a carbothermic ferroboration with a low content the boron content must be high, the higher the boron content the lower the carbon solubility and thus carbon pick up.
- The reduction of boric oxide by carbon requires high temperature; therefore, the process is carried out in an electric arc furnace .
- In a Japanese patent the carbothermic production of ferroboration from boric acid, iron powder, and charcoal in a Heroult-type electric-arc furnace with carbon lining is claimed. One example describes the production of an alloy with 10.3% B, 2% Si and 0.98% C in a three phase electric –arc furnace. The mix is 100 parts boric acid, 135.8 parts iron powder (92.9% Fe), and 57 parts charcoal powder. The boron recovery is 81.7% .
- The production of ferroboration from pig iron and boric acid in an electric arc furnace with a final oxygen blow leads to an alloy with 16.3% B, 0.03-0.06% Al, and 0.03-0.06% C. the boron recovery in small scale runs is said to be 60-65%.

#### ALUMINOTHERMIC PRODUCTION

- Ferroboration can be made batchwise in convenient way by the reduction of boric oxide and iron oxide with aluminum powder. Some magnesium in the aluminothermic mix is beneficial; magnesium is the stronger reducing agent at the temperatures below its boiling point, whereas aluminum is more effective above the boiling point of magnesium, where such metallothermic reactions generally take place
- The aluminothermic coreduction of boric oxide and iron oxide ( $\text{Fe}_2\text{O}_3$ ) is highly exothermic, and only a little additional energy is necessary for a self-propagating reaction.
- The thoroughly mixed compounds are charged into refractory-lined pot and ignited, either the whole mix or by igniting a starting mix, the rest then charged as the reaction proceeds over a few minutes.  
The liquid metal slag separate on account of differing densities, and after cooling the metal button, up to 1500 kg, is removed. After mechanical cleaning, the metal button is broken and crushed to the desired size.

#### ❖ FERRONIUM

- Approximately 85-90% of the total niobium production is used in the steel industry in the form of iron niobium alloy containing 40-70% niobium.

#### ❖ PRODUCTION

- Ferroniobium is usually produced by aluminothermic reduction of niobium oxide ores with the addition of iron oxides ores, with the addition of iron oxides if the niobium ore used contains insufficient iron.
- The starting materials are mainly columbites and pyrochlore concentrates.
- The enthalpy of the reaction between  $\text{Nb}_2\text{O}_5$  and Al is  $-276.1 \text{ kJ/mol Al}$ , which is lower than the threshold value for self-sustaining aluminothermic reactions
- The mixture must therefore either be preheated or mixed with oxygen releasing compounds such as  $\text{BaO}_2$ ,  $\text{CaO}_2$ , etc. Concentrates with lower percentages of

niobium can also be treated by the aluminothermic process in an electric arc furnace.

- Also, a two stage electroaluminothermic process for the production of ferroniobium from columbite has been developed. The method of operation is to charge the mixture of niobium concentrate with the additives to refractory lined reaction vessels.
- Either the whole mixture is reacted, or a small amount is set aside, ignited with a special exothermic mixture, and added to the bulk mixture.
- The molten reaction product is allowed to solidify in the furnace, and the block of metal separates from the slag.
- After cooling, it is broken into pieces of the required size.

#### ❖ FERROTITANIUM

- Ferrotitanium is described in DIN 17566 as a master alloy containing at least 28%Ti, obtained by reduction of the corresponding raw materials or their concentrates. The International Standard for ferrotitanium is ISO 5454-1980, which specifies a Ti content of at least 20% and allows greater variation in the Al content.

#### ❖ PRODUCTION

- The starting materials for the production of ferrotitanium are ilmenite, leucosilite, perovskite, and slag concentrates produced from ilmenite.
- Because of the increasing availability of titanium scrap, this is also used to an increasing extent for the production of ferrotitanium.

#### ❖ REDUCTION WITH CARBON.

- Carbothermic production in electric arc furnaces leads to high carbon contents in the ferrotitanium. However, as the main use of ferrotitanium is to combine with the carbon in steel, the presence of carbon in the ferrotitanium is undesirable, and this production method is therefore now hardly used.

#### ❖ METALLOTHERMIC PRODUCTION.

- Ferrotitanium containing 28-50% Ti and 4.5-7%Al. These are mainly produced by the aluminothermic process. The reduction of TiO<sub>2</sub> by Al proceeds via TiO.
  - $3\text{TiO}_2 + 2\text{Al} \rightarrow 3\text{TiO} + \text{Al}_2\text{O}_3$
  - $3\text{TiO} + 2\text{Al} \rightarrow 3\text{Ti} + \text{Al}_2\text{O}_3$
- If there is too much TiO<sub>2</sub> in the reaction mixture, TiO can be formed as a third phase besides the metal and slag. In the aluminothermic production of ferrotitanium there is a high consumption of aluminum, as it reacts both with the iron oxide in the ilmenite and with the oxygen –producing substances added to increase the exothermicity.
- An aluminothermic mixture, consisting, for example of 4320 kg Australian ilmenite (58.55%TiO<sub>2</sub>), 480 kg rutile (96.7% TiO<sub>2</sub>), 190 kg calcined limestone, 107 kg potassium perchlorate, and 1693 kg Al powder, is placed in a refractory-lined combustion vessel and ignited to start the reaction. After cooling, a 2250 kg block of ferrotitanium is obtained containing 39.8%Ti, 6.7%Al, 3.4%Si, and 0.02%C, which separates well from the slag. The titanium yield is 50%, and the specific consumption of aluminum is 1.89kg Al/kg Ti.

❖ **PRODUCTION FROM TITANIUM SCRAP AND SPONGE.**

- As the availability of titanium scrap is increasing with the growth in the consumption of titanium, it is being increasingly used for the production of ferrotitanium and ferrotitaniumsilicon.
- Because of its low melting point (1100°C) the alloy containing 70% titanium melts comparatively readily when alloyed with iron in an induction furnace, in an arc furnace with consumable electrodes under vacuum or argon, or in an electroslag melting furnace.