

**A Laboratory manual**  
**For**  
**WORKSHOP PRACTICE – III (PR- 3)**

**In accordance to syllabus (2019-20)**

**By S.C.T.E & V.T, Odisha**

**Semester – 4<sup>th</sup>**

**DEPARTMENT OF MECHANICAL ENGINEERING**



**GOVERNMENT POLYTECHNIC, JAJPUR**

**ODISHA – 755019**

**Affiliated to S.C.T.E & V.T, Odisha and A.I.C.T.E,**

**New Delhi**



# GOVERNMENT POLYTECHNIC, JAJPUR

## CERTIFICATE

This is to certify that Mr./Ms.: - .....

Bearing registration no: - ..... of Fourth semester Diploma in Mechanical Engineering has completed the term work satisfactorily in course Workshop practice – III for the academic year: - ..... as prescribed in the curriculum.

Place: - .....

Date: - .....

Signature

Signature

Signature

Course Teacher

HOD/ Mechanical

Principal

## **Programme Outcomes (POs) to be achieved through Practical of this Course**

Following POs and PSO are expected to be achieved through the practical's of the Workshop Practice course.

**PO1. Engineering knowledge:** Apply the knowledge of mathematics, science, engineering

fundamentals, and an engineering specialization to the solution of complex engineering problems.

**PO5. Modern tool usage:** Create, select, and apply appropriate techniques, resources, and modern

engineering and IT tools including prediction and modelling to complex engineering activities with an

understanding of the limitations.

**PO6. The engineer and society:** Apply reasoning informed by the contextual knowledge to assess

societal, health, safety, legal and cultural issues and the consequent responsibilities relevant to the

professional engineering practice.

**PO7. Environment and sustainability:** Understand the impact of the professional engineering solutions

in societal and environmental contexts, and demonstrate the knowledge of, and need for

sustainable development.

**PO9. Individual and team work:** Function effectively as an individual, and as a member or leader in

diverse teams, and in multidisciplinary settings.

**PO11. Project management and finance:** Demonstrate knowledge and understanding of the

engineering and management principles and apply these to one's own work, as a member and

leader in a team, to manage projects and in multidisciplinary environments.

**PO12. Life-long learning:** Recognize the need for, and have the preparation and ability to engage in

independent and life-long learning in the broadest context of technological change.

**PSO1: Manage Safety measures and associated Hazards During processes:** Usage of different personal protective Equipment's (PPES) against associated hazards during work with different machine, methods, materials and their process.

**PSO 2: Maintenance and selection of machines, equipment, instruments:** Maintain and select appropriate machine, equipment and instrument in the field of Mechanical Engineering.

**PSO 3: Manage Mechanical Process in CNC :** Manage the mechanical processes by selection and scheduling right type of machinery, equipment, quality control techniques, operational parameters for productivity improvements.

## **List of Industry Relevant Skills**

The following industry relevant skills of the competency will be gained from different types of machining practices like Shaper, conventional lathe, milling, & CNC lathe for engineering applications are expected to be developed in you by undertaking the practices of this workshop manual.

1. Applicable in various manufacturing industries like Automotive, Aerospace, Heavy Engineering, and other oil and gas sectors maintenance job work and developments of new parts.
2. Machining works applicable for different child part processes by using different machine and their operational parameters.
3. Understand different machining tools, equipment's & metrology used for getting a finished parts.

## Practical-Course Outcome Matrix

<b>Course Outcomes:</b>						
<b>CO1:</b> Understanding the tools, equipment & Instruments used in the practices.						
<b>CO2:</b> Understanding the machining parameter's involved for different operation in jobs.						
<b>CO3:</b> Understanding different codes and programed used in for machining process involved with accuracy and precision jobs.						
<b>CO4:</b> standard Operational procedure of both conventional and CNC lathe machine, Milling And shaper machine.						
<b>CO5:</b> Understanding different safety and associated Hazards during work.						
<b>S.no</b>	<b>Practical Outcome</b>	<b>CO1</b>	<b>CO2</b>	<b>CO3</b>	<b>CO4</b>	<b>CO5</b>
<b>(1)</b>	<b>Machining Practices</b>	✓	✓	-	✓	✓
<b>1.1</b>	Job in evolving drilling, boring					
<b>1.2</b>	Internal/External threading on Turning jobs	✓	✓	-	✓	✓
<b>1.3</b>	Job in evolving use of Capstan and turret lathe (Taper Turning & Chamfering)	✓	✓	-	✓	✓
<b>1.4</b>	All gear lathe, CNC Lathe Trainer Practice Job involving all turning process on MS Rod & aluminum rod for jobs using CNC Lathe trainer.	✓	✓	✓	✓	✓
<b>(2)</b>	<b>Metal Machining</b>	✓	✓	-	✓	✓
<b>2.1</b>	Shaper Preparation of V Block on CI or MS Blocks					
<b>2.2</b>	Milling Machine Preparation of Spur gear on CI or MS round	✓	✓	-	✓	✓

## **GUIDELINES TO TEACHERS**

1. Teacher need to ensure that a dated log book for the whole semester, apart from the laboratory manual is maintained by every student which s/he has to submit for assessment to the teacher in the next practical session.
2. There will be two sheets of blank pages after every practical for the student to report other matters (if any), which is not mentioned in the printed practicals.
3. For difficult practicals if required, teacher could provide the demonstration of the practical emphasizing of the skills which the student should achieve.
4. Teachers should give opportunity to students for hands-on after the demonstration.
5. Assess the skill achievement of the students and COs of each unit.
6. One or two questions ought to be added in each practical for different batches. For this teachers can maintain various practical related question bank for each course.
7. If some repetitive information like data sheet, use of software tools etc. has to be provided for effective attainment of practical outcomes, they can be incorporated in Appendix.
8. For effective implementation and attainment of practical outcomes, teacher ought to ensure that in the beginning itself of each practical, students must read through the complete write-up of that practical sheet.
9. During practical, ensure that each student gets chance and takes active part in taking observations/readings and performing practical.
10. Teacher ought to assess the performance of students continuously according to the MSBTE guidelines.

## **INSTRUCTIONS FOR STUDENTS**

1. For incidental writing on the day of each practical session every student should maintain a dated log book for the whole semester, apart from this laboratory manual which s/he has to submit for assessment to the teacher in the next practical session.
2. For effective implementation and attainment of practical outcomes, in the beginning itself of each practical, students need to read through the complete write-up including the practical related questions and assessment scheme of that practical sheet.
3. Student ought to refer the data books, IS codes, Safety norms, Electricity act/rules, Technical manuals, etc.
4. Student should not hesitate to ask any difficulties they face during the conduct of practical.

## CONTENTS PAGE

Sl. no	Practical Outcome	Page No:	Date of performance	Date of submission	Signature	Remarks
<b>(1)</b>	<b>Machining Practices</b>					
1.1	Job in evolving drilling, boring					
1.2	Internal/External threading on Turning jobs					
1.3	Job in evolving use of Capstan and turret lathe (Taper Turning & Chamfering)					
1.4	All gear lathe, CNC Lathe Trainer Practice Job involving all turning process on MS Rod & aluminum rod for jobs using CNC Lathe trainer.					
<b>(2)</b>	<b>Metal Machining</b>					
2.1	Shaper Preparation of V Block on CI or MS Blocks					
2.2	Milling Machine Preparation of Spur gear on CI or MS round					

## ExperimentNo-01

### Aim of the experiment:

To make a drill on a round bar using lathe.

### Apparatus required:-

Sl no	Name of the apparatus	Specification	Quantity
1	Drill bit	Ø16 mm	1
2	Drill chuck	1-12 mm	1
3	Socket/sleeve	1-2 "	1
4	Lathe	4'	1

### Raw material required:-

MS ROD of diameter 32mm and length 60mm.

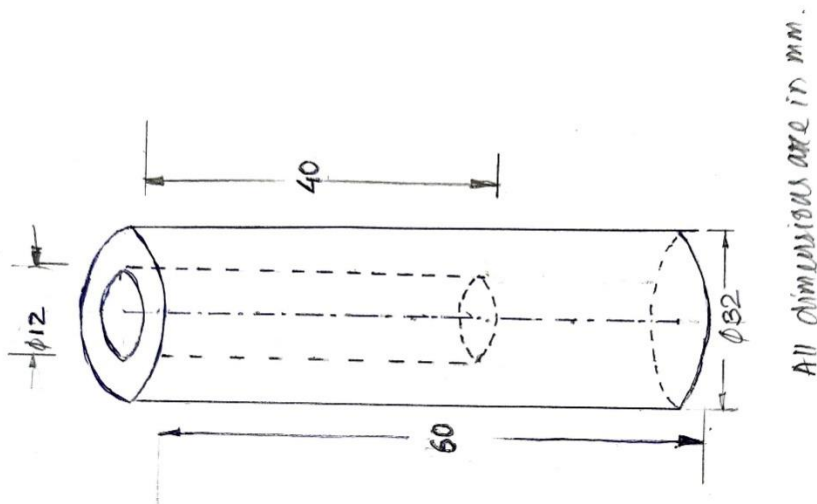

### Procedure:-

- At first the round bar is fitted on the lathe chuck properly by the help of a surface gauge & chuck key.
- Then facing operation is done on the job and after that plain turning is done.

- Locate the centre of the work piece by using tailstock.
- Now the dead centre is removed from the tailstock and a socket with sleeve and a drill bit fitted into it.
- Now we run the lathe machine by making power switch on.
- After this the drill bit is required to move forward by the tail stock hand wheel which will penetrate into the rotated job and drilled the required sized hole.

**Conclusion:-**

Finally we made a drill ( $\text{Ø}12 \text{ mm}$ ) on the given round bar.

**Resources used (with major specifications)**

Sl no.	Name of the apparatus	Specification	Quantity
01			
02			
03			
04			
05			
06			
07			

**Actual procedure followed:**

**Precautions followed:**

**Observations:**



**Results:**

**Interpretation of results:**

**Conclusions and recommendations if any:**

**Practical related questions:**

1. The drill bit is made up which material?
2. What is the lip angle of drill bit ?
3. On which type of guide ways the tail stock slides?
4. Which mechanism is used to lock & unlock the tail stock?

**Space for answer**

## ExperimentNo-02

### Aim of the experiment:-

To do boring operation on a work piece using lathe.

### Apparatus required:-

Sl no	Name of the apparatus	Specification	Quantity
01	Drill bit	Ø16 mm	1
02	Drill chuck	1-12 mm	1
03	Socket/Sleeve	1-2"	1
04	Lathe	4'	1
05	Boring tool	4"	1

### Raw material required:-

MS ROD of diameter 32mm and length 60mm.

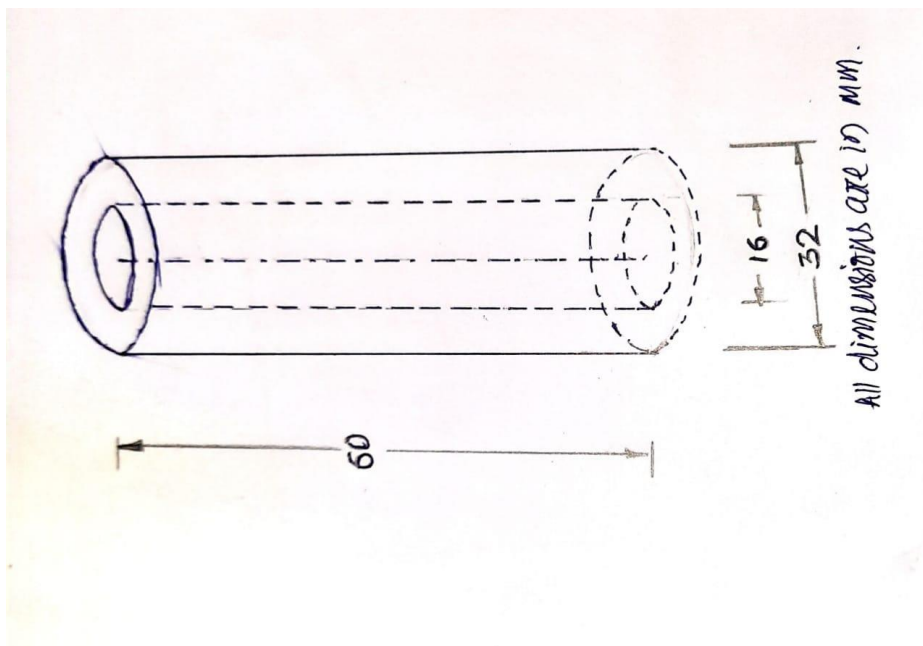

### Procedure:-

- At first the workpiece is fitted properly on the lathe chuck by the help of a surface gauge & chuck key.
- Then facing and plain turning is done on the workpiece.
- The centre of the work piece is located by the help of tail stock.
- Now we run the lathe machine by making power switch on
- Now a drill bit is to be fitted with the tail stock and to be locked and then the drill will penetrated in to the rotating workpiece and sufficient feed is given until the required drilling is done.
- After drilling, the drill bit is removed and a boring tool is fitted into the toolpost.

- Then the boring operation is done by the boring tool which is generally used to enlarge the drilled hole.

**Conclusion:-**

Finally we did the boring operation on the given round bar.

**Resources used (with major specifications)**

Sl no.	Name of the apparatus	Specification	Quantity
01			
02			
03			
04			
05			
06			
07			

**Actual procedure followed:**

**Precautions followed:**

**Observations:**

**Results:**

**Interpretation of results:**

**Conclusions and recommendations if any:**

**Practical related questions:**

1. The boring tool is made up which material?
2. What is boring operation ?
3. What are the specification of boring tool?
4. What is the difference between drilling & boring ?

**Space for answer**

## ExperimentNo-03

### Aim of the experiment:-

External V-thread cutting by the help of a V-thread cutting tool using lathe.

### Apparatus required:-

SI no	Name of the apparatus	Specification	Quantity
01	Drill bit	Ø16 mm	1
02	Drill chuck	1-12 mm	1
03	V-thread cutting tool	HSS 4"	1
04	Lathe	4'	1

### Raw material required:-

MS ROD of major diameter 13.54mm and length 100mm.

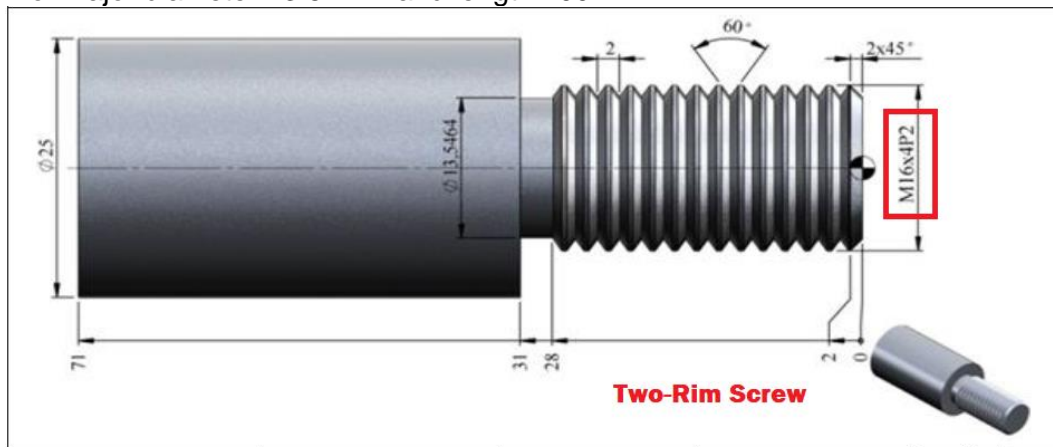

### Procedure:-

1. First of all the job will fitted in the lathe chuck and properly centred by surface gauge .
2. Then facing is done on the job and the centerheight was found out and marked by using dead center.
3. Fix the v-thread cutting tool on the tool post.
3. According to pitch we have to set the feed gear box.
4. Now we run the lathe machine by making power switch on.
5. Now we have to engage the half nut.
6. Now we start cutting with proper cutting depth from right side to left side.
7. Repeat the process till the thread will completely obtained.

### Conclusion:-

Hence the external V-threading is done successfully by the help of required machine and tool.

**Resources used (with major specifications)**

Sl no.	Name of the apparatus	Specification	Quantity
01			
02			
03			
04			
05			
06			
07			

**Actual procedure followed:**

**Precautions followed:**

**Observations:**

**Results:**

**Interpretation of results:**

**Conclusions and recommendations if any:**

**Practical related questions:**

1. What is the angle of V-thread?
2. What is major and minor diameter of a thread?
3. What is pitch?
4. What is tool material of thread cutting tool?

**Space for answer**



## ExperimentNo-04

### Aim of the experiement:

Job in evolving use of Capstan and turret lathe

### Apparatus required:

SI no.	Name of the apparatus	Specification	Quantity
01	Capstan turrentLathe	4'	01
02	Lathe Cutting Tool	4"	01
03	Chuck Key	100 mm	01
04	Box Spanner	10 mm	01

### Raw material required:

M.S. Rod of Diameter 40mm and length 100mm.

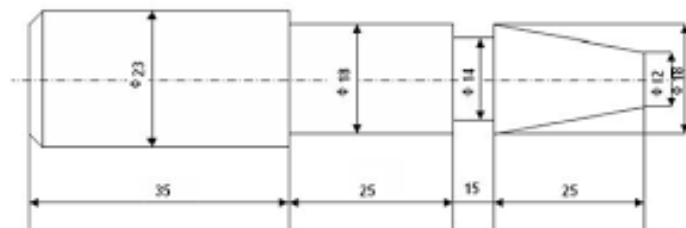

STEP TURNING AND TAPER TURNING

ALL DIMENSIONS ARE IN MM

### Procedure:

1. At first the round bar is fitted on the lathe chuck properly by the help of a surface gauge & chuck key.
2. Then checked out the centring of the job and tool by the help of surface gauge and dead centre respectively.
3. Now we run the lathe machine by making power switch on.
4. Then various operations are done by the help of capstan and turretlathe successfully.

### Conclusion:

From this practice we have done Taper Turning & Chamfering operation by using capstan & turret lathe.

**Resources used (with major specifications)**

Sl no.	Name of the apparatus	Specification	Quantity
01			
02			
03			
04			
05			
06			
07			

**Actual procedure followed:**

**Precautions followed:**

**Observations:**

**Results:**

**Interpretation of results:**

**Conclusions and recommendations if any:**

**Practical related questions:**

1. What type of chuck used in capstan and turret lathe?
2. What is single point cutting tool ?
3. Which mechanism is used for taper operation?
4. What is the formula for taper angle?

**Space for answer**

## ExperimentNo-05

### Aim of the experiement:

CNC Lathe Trainer Practice Job involving all turning process on MS Rod & aluminum rod for jobs using CNC Lathe trainer.

### Theory :

Turning is a subtractive machining process that uses a cutting tool to remove material for creating cylindrical parts. The tool itself moves along the axis of the machined part while the part is rotating, creating a helical toolpath.

The lathe machine is historically one of the earliest of its kind for producing parts in a semi-automated fashion. Today, most companies provide CNC turning services. This means that the process is largely automated from start to finish.

CNC refers to computer numerical control, meaning that computerised systems take control of the machinery. The input is digital code. This controls all the tool movements and speed for spinning as well as other supporting actions like the use of coolant.

### Procedure:

#### CNC Turning Process

What does the turning process actually comprise of? While the cutting itself is pretty straightforward, we are going to look at the whole sequence here which actually starts from creating a CAD file.

The steps of the process are:

- Creating a digital representation of the part in CAD
- Creating the machining code from the CAD files
- CNC lathe setup
- Manufacturing of the turned parts

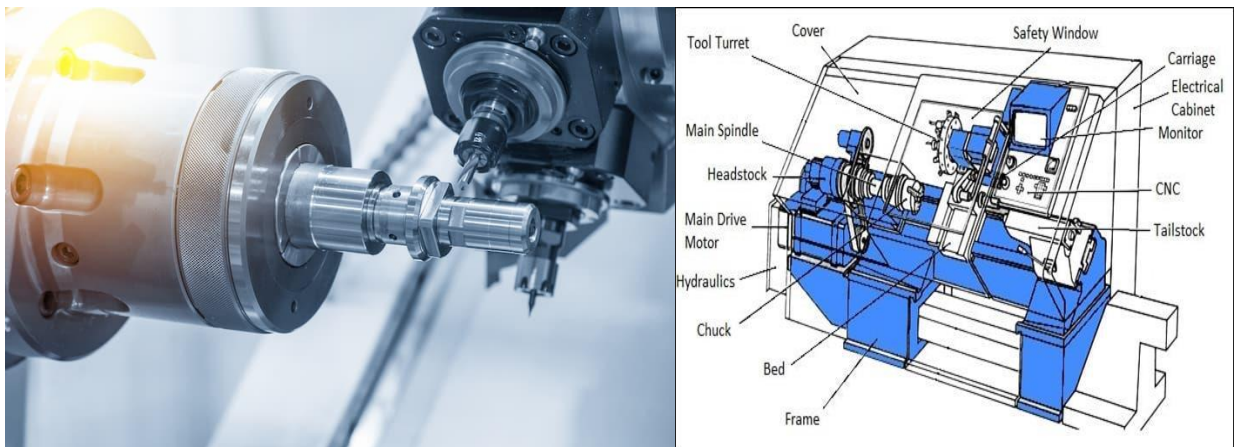

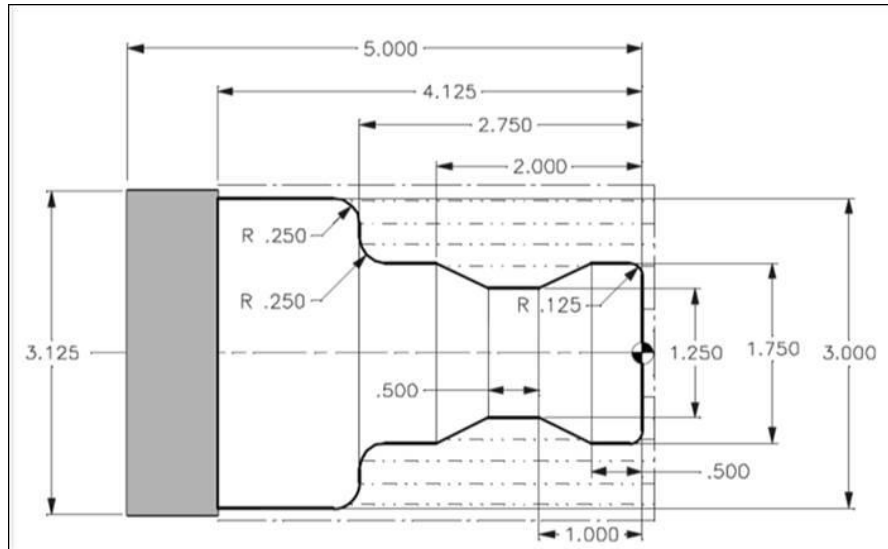

**Raw material required :**M.S Rod , Aluminium

### CAD design & G code

The first 2 steps can be seen as separate or going hand-in-hand. One way is to just use a CAD program to create the files and send them into production. The manufacturing engineer will then create the G code and the M code for the machining job.

Another way is to just use CAD-CAM software which lets the design engineer test the producibility of the part. The powerful simulation tools can visualise the whole process from raw material to the final product, even using the input regarding finishing requirements.

### Lathe setup

Next comes the machine setup. This is where the machine operator's role becomes evident. Although contemporary CNC lathes do most of the work automatically, the operator still plays a vital part. Steps for setting up a CNC turning centre:

- **Making sure the power is off.** CNC machining can be dangerous, so extra care is necessary and checking the power switch is the basis for that.
- **Securing the part into the chuck.** The chuck holds the part during the whole process. Improper loading can both pose dangers as well as result in a finished part with the wrong dimensions.
- **Loading the tool turret.** Turning comprises of many steps, so be sure to choose the right tooling for a certain finish. The turret can hold many tools at once for a seamless operation from start to finish.
- **Calibration.** Both the tool and part have to be set up in the right way. If anything is off, the result will not meet the demands.
- **Upload the program.** The last step before pushing the start button is uploading the code to the CNC machine.

### Turning Parameters

The parameters of CNC turning depend on various aspects. These include the material of the part and tool, tool size, finishing requirements, etc. The main parameters for CNC turning are:

- **Spindle speed.** The unit is rotations per minute (rpm) and it shows the rotational speed of the spindle ( $N$ ), thus also the workpiece. The spindle speed is in direct correlation with the cutting speed which also takes the diameter into account. Therefore, the spindle speed should vary to maintain a constant cutting speed if the diameter changes considerably.
- **Workpiece diameter.** As said, this plays an important role to arrive at the right cutting speed. The symbol is  $D$  and the unit is mm.
- **Cutting speed.** The equation for calculating the cutting speed is  $V=\pi DN/1000$ . It shows the relative speed of the workpiece to the cutting tool.
- **Feed rate.** The unit is mm/rev and the symbol is  $s$ . Cutting feed shows the distance the cutting tool moves per one turn of the workpiece. The distance is measured axially.
- **Axial cut depth.** Pretty self-explanatory as it shows the depth of a cut in the axial direction. It is the primary parameter for facing operations. A higher feed rate puts more pressure on the cutting tool, shortening its lifetime.
- **Radial cut depth.** The opposite of axial cut, it shows the depth of cutting perpendicular to the axis. Again, lower feed rates help to lengthen the lifetime of tools and secure a better finish.

### **CNC Lathe Main Parts**

Now, let's see the main components of a turning centre.

#### **Headstock**

The headstock of a CNC lathe makes up the front section of the machine. This is where the driving motor is along the mechanisms to power the spindle.

The chuck or collet attaches to the spindle. Either of them, in turn, holds the workpiece during the turning operation.

#### **Chuck and collet**

The chuck grips the machined part by its jaws. It attaches directly to the spindle but is replaceable, so different sized parts can be machined.

Collet is basically a smaller version of a chuck. The part size suitable for collets is up to 60 mm. They provide a better grip for small parts.

#### **Tailstock**

The other end of a CNC turning centre. A tailstock attaches directly to the bed and its purpose is to provide support for longer workpieces. The tailstock quill provides the support by hydraulic force.

The driving force still comes from the spindle and the tailstock just runs with the part. Using a tailstock is not suitable when face turning is necessary, as it will be in the way.

#### **Lathe bed**

The bed is just a base plate that rests on the table, supporting other machine parts. The carriage runs over the bed which is heat-treated to withstand the machining effects.

#### **Carriage**

The carriage rests on ways for sliding alongside the spinning workpiece. It holds the tools, allowing for cutting process to take place.

#### **Turret**

Newer machines usually come with a turret that replaces the carriage. They can hold more tools at the same time, making the switching from one operation to the other less time-consuming.

#### **Control panel**

This is where computer numerical control kicks in. The brains of CNC turning machines are just behind the panel. The panel itself allows the operator to adjust the program and start it.

**Practical questions :**

1. What is the difference between conventional lathe and CNC lathe?
2. To operate CNC lathe what are the basic requirements?
3. What are the different parts of CNC lathe?
4. What do you mean by G- code & M-code?
5. What are the advantages of CNC lathe over conventional lathe?

**Space for answer**

## ExperimentNo-06

### Aim of the experiement:

Preparation of V Block on CI or MS Blocks by using shaper machine.

### Tools and equipment required:

- Shaper machine
- Manual operating handle
- Shaper single point cutting tool

### Marking and measuring tools:

- Scriber
- Dot punch
- Ball peen hammer
- Varnier caliper

### Raw material required :

M.S block according to the given dimension in diagram (50×40 ×40)mm

### Figure :

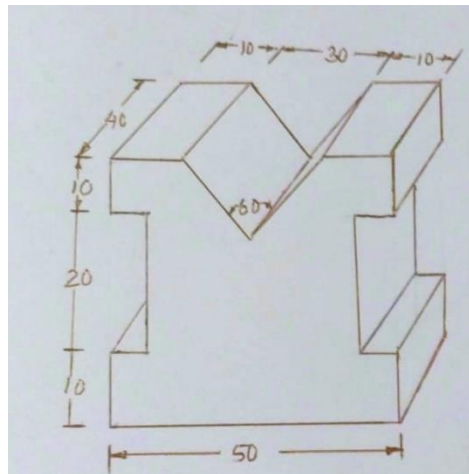

### Procedure :

1. Take a block of dimension (50×50 ×50)mm then using proper marking media. Mark the block according to the given diaram.
2. Fix the raw material in the machine viceand also fix the required cutting tool in the tool post of the shaper machine
3. Set the swiveling tool post at proper angle
4. Then start the machine from zero feed depth to the required depth of raw material with the marking & make the v-block.

### Conclusion :

From this practice we have done V Block on CI by proper machine tool & procedure.



**Practical questions :**

1. What are the different types of shaper machine?
2. Which mechanism is used in shaper machine ?
3. Which material is used as a cutting tool in shaper M/c?
4. What are the basic difference between shaper and slotter M/C?
5. What is the function of clapper box?

**Space for answer**

## ExperimentNo-07

### Aim of the experiment:

Preparation of Spur gear on CI or MS round by using milling m/c.

### **Apparatus required :**

- Universal milling machine
- Spur gear milling cutter (Module 3)
- Spanner
- Indexing plate
- spindle rotating handles

### **Raw material required :**

Circular M.S plate as per required diameter and thickness.

### **Figure :**

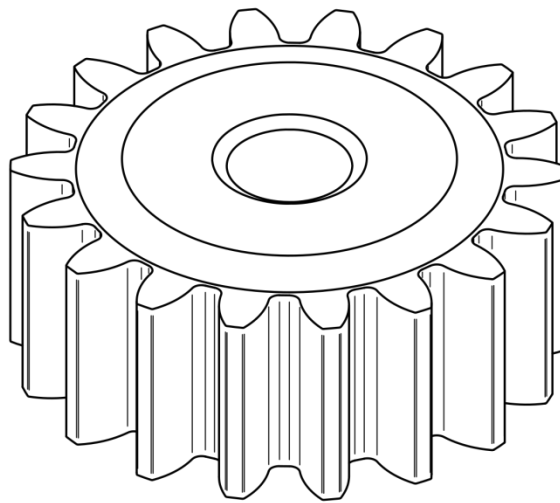

(Take suitable dimension )

### **Procedure:**

1. At first calculate the blank diameter of the material by selecting the required no. of teeth by the following formulae

$$\text{Blank diameter} = m(T+2)$$

m – Module

T – No. of teeth

2. Make a hole at the centre of the raw material for fixing at chulk according to the diameter of the spindle.

3. Fix the raw material in between the tail stock and chulk tightening.

4. Then fix the cutting tool in the arbor.

5. Calculate the depth of the teeth by the formula =  $2.25 \times m$  and Pitch =  $3 \times m$

6. Again calculate indexing hole and rotation of the indexing spindle =  $40 / \text{No. of teeth}$

7. Now fix the depth of cut according to calculation.

8. Cut the teeth accordingly by the simple indexing method

### **Conclusion :**

From this practice we finally able to make a spur gear by following proper M/C tool and procedure.

**Practical questions :**

1. Write the specification of milling cutter used to make the job?
2. What are the types indexing method/
3. What are the difference between up milling and down milling?
4. What is pitch circle diameter of a spur gear?
5. The milling cutter is made up which material?

**Space for answer**