



GOVT. POLYTECHNIC, JAIPUR

Department of Civil Engineering

LECTURE NOTE- Advanced construction techniques & Equipment

Prepared by – Ajit Kumar Behera

Advanced construction materials

1.1 Fibers and Plastics-

Fiber or fibers is a class of material which are having continuous filaments or having discrete elongated pieces similar to the length of thread. Fibers are very important in the biology of plants and animals for holding tissue together. They are often used in the manufacture of other materials. Fibers can be spun into filaments or string or rope which can be used as a component of composite material or matted into sheets so as to make the products like paper or felt. Fibers are inorganic or organic, natural or synthetic. Synthetic fibers can be produced very cheaply and in large amounts as compared to natural fibers. Rayon and nylon are organic synthetic fibers. Burlap is a coarse jute or hemp which is a natural fiber. Hessian is a jute fabric. Silk and cotton are produced from natural fibers. Glass wool, lead wool and asbestos are mineral fibers of which glass wool and lead wool are synthetic fibers. Steel fiber, carbon fiber and glass fiber are the new and recent trends used in the construction work.

General Uses of Fibers

- Fibers are used for packing and making fabrics and felts.
- Glass wool made of very fine fibers of glass is used for making acid-proof and fire-proof fabrics.
- Glass wool is also used as a packing material for heat, sound and electric insulation. It is commonly used in a solar water system.
- Lead wool prepared from fine fibers of lead is used in water pipe joints to stop leakage of water. Natural jute fibers are extensively used in plumbing work to stop leakage of water.

Types of Fibers :

There are mainly three types of fibers which are commonly used as a [construction materials](#).

1. Steel fiber

Steel fibers are made from the cold drawn steel wire with low content of carbon or stainless steel wire. They are manufactured in various types such as hooked steel fibers, undulated or flat steel fibers according to the need required in the construction project. These fibers are used in the construction for concrete reinforcement. Steel fiber reinforced concrete is less expensive

than hand tied re-bar shape, dimensions and length of the fiber are more important because it increases the tensile strength of the concrete.

Steel fibers can only be used on surfaces so as to avoid corrosion and rust stains. Fiber-reinforced normal concrete is mostly used for on-ground floors and pavements and also used for the construction parts such as beams, pillars, foundation etc.

Properties of Steel Fibers

- It increases the tensile strength of concrete.
- It is more tough and hard.
- It avoids corrosion and rust stains.
- They are more elastic in nature.
- Steel fibers are available with standards as ASTM 820/96, ASTM C 1116/95 and DIN 1045.
- It has a tensile strength of 1.100 N/mm².
- They are available in the shapes like flat, hooked and undulated.

Applications of Steel Fibers on Field

- Steel fibers are highly used in tunnel lining work.
- It is mostly used in the construction of airport runways and highway pavements.
- Most commonly used in precast concrete so as to increase the tensile strength.
- They are used in shotcrete.
- Used in the construction of parking.
- It is used in anti-seismic buildings.

2. Carbon fibers

Carbon fiber is a material consisting of extremely thin fibers about 0.005 mm to 0.010 mm in diameter and mostly composed of carbon atoms. Carbon fiber

is alternately called graphite fiber. The carbon atoms are bonded together in microscopic crystals which are more or less aligned parallel to the long axis of the fiber. The crystal alignment makes size of fiber more strong. Number of carbon fibers are twisted together so as to form a Yarn which can be used as it exist or woven into a fabric. It can be combined with a plastic resin and wound or moulded to form composite materials like carbon fiber reinforced plastic to provide a high strength to weight ratio of the materials. The atomic structure of carbon fiber is similar to that of graphite consisting of sheets of carbon atoms arranged in a regular hexagonal pattern. Carbon fibers shows the number of properties very close to the properties of asbestos. Each carbon filament thread is a bundle of many thousand carbon filaments. A single such filament is a thin tube with a diameter of 5-8 μm (i.e. 5-8 micrometers) and consists of almost exclusively of carbon.

Properties of Carbon Fibers

- It has a high tensile strength, low weight and low thermal expansion.
- They are rigid materials which are resistant to stretching and compression.
- It is chemically inert or unreactive materials.
- They are resistant to corrosion.
- Fibers contained about 85% carbon has excellent flexural strength.

Application of Carbon Fibers

- Carbon fiber is mostly used to reinforce composite material.
- Reinforced Carbon-Carbon (RCC) consists of carbon fiber-reinforced graphite and is used structurally in high temperature applications.
- It increases the tensile as well as compressive strength of concrete.
- Due to high tensile strength, low weight and low thermal expansion it makes the carbon fiber very popular in aerospace, military and motorsports along with other competition sports.
- Carbon fiber is extensively used in the bicycle industry, especially for high-performance racing bikes.
- It is also used in some tennis rackets.

- It is now being used in musical instruments for its weather resilience and ability to recreate the tone of guitars.

3. Glass fibers

It is also called as fiber glass. Glass fiber is the material made from extremely fine fibers of glass. It was invented in 1938 by Russell Games Slayter. In 1893, Edward Drummond Libbey exhibited a dress at the World's Calumbian Exposition incorporating glass fibers with the diameter and texture of silk fibers. This was first worn by the well known and popular stage actress of the time Georgia Cayvan. There are two main types of glass fiber manufacture and two main types of glass fiber product. First fiber is made either from a direct melt process or a marble remelt process. Both start with the raw materials in solid form. It is almost and always made of platinum alloyed with rhodium for better durability. Platinum is used because the glass melt has a natural affinity for wetting it. The fresh and thin fibers are more strong because the thinner fibers are more ductile.

Properties of Glass Fibers

- It has high ratio of surface area to weight.
- They have good thermal insulation.
- It has a good tensile strength but has no strength against compression.
- Compressive strength is weak but can be increased by reinforcing it with plastic.
- When the glass fiber is reinforced with plastic, then reinforced material can resist both compressive and tensile forces as well.
- It is resistant to chemical attack. However, if its surface area is increased, then it makes them more susceptible to chemical attack.
- They are corrosion resistant.

Application of Glass Fibers

- Corrugated fiber glass panels are widely used for outdoor canopy or greenhouse construction.
- It is used as a reinforcing agent for many polymer products like FRP and GRP which uses tubs, pipes for drinking water and 'sewers, office plant containers and flat roof systems etc.

- It is reinforced with plastic material so as to increase tensile strength.
- Uses of regular fiber glass are mats, insulation, reinforcement sound absorption, heat resistance fabrics, corrosion resistant fabrics and high strength fabrics.
- Glass fiber reinforced plastics are used in the house building market for the production of roofing laminate, door surrounds, over-door canopies, window canopies and dormers, chimneys, coping system, heads with keystone and sill etc.
- The reinforced glass fiber with polymer and plastic is commonly used in fire water systems, cooling water systems, drinking water systems, sewage systems, waste water systems, gas system etc.

What is plastic

Plastics are a wide range of synthetic or semi-synthetic materials that use polymers as a main ingredient. Their plasticity makes it possible for plastics to be moulded, extruded or pressed into solid objects of various shapes.

PVC

Polyvinyl Chloride (PVC or Vinyl) is an economical and versatile thermoplastic polymer widely used in building and construction industry to produce door and window profiles, pipes (drinking and wastewater), wire and cable insulation, medical devices, etc. It is the world's third largest thermoplastic material by volume after [polyethylene](#) and [polypropylene](#).

It is a white, brittle solid material available in powder form or granules. Due to its versatile properties, such as lightweight, durable, low cost and easy processability, PVC is now replacing traditional building materials like wood, metal, concrete, rubber, ceramics, etc.

RPVC

RPVC means Rigid PolyVinyl Chloride which comes from PVC. Polyvinyl chloride (PVC), also known as vinyl, is a common plastic polymer (a polymer being a large molecule). It

comes in two basic forms: flexible and rigid (RPVC). RPVC is used in construction (especially pipes), packaging (especially bottles), and credit cards, just to list a few examples. RPVC Pipes with high impact strength & load bearing capacity!

About

Rigid PVC pipes are manufactured from the basic material Poly Vinyl Chloride of Suspension Grade, K value 67, and are suitable for pressure pipes. RPVC has properties which have advantages over traditional materials such as cast iron, asbestos, cement, clay & wood.

Features

- Strong & durable
- Flexible, light-weight & hence easy to transport
- Easy installation & low maintenance
- High electrical & chemical resistance
- Termite proof & UV resistant
- Manufactured conforming to IS 4985:2000 standards
- Resistant to moisture, abrasion & wearing
- Solvent Cement Jointing facility

Applications (Agricultural/ Industrial/ Domestic / Other)

- Suitable for the irrigation system
- Disposal of chemical effluent & waste
- Acid & slurry transportation
- Saltwater handling
- Potable water supply schemes in urban areas
- Telecommunication cable ducting

High-density polyethylene

HDPE is a commonly used petroleum thermoplastic and the most used of the three polyethylenes for a wide range of applications. If you look at this plastic under a microscope, you would see that it has a linear structure with few branches leading to its optimal strength/density ratio. As a result of its molecular makeup, this polymer shines brightest in applications where moisture resistance and cost-effectiveness are needed

Uses of Plastics

There are variety of plastics made to suit different uses. The typical uses of plastics in buildings is listed below:

1. Corrugated and plain sheets for roofing.
2. For making jointless flooring.
3. Flooring tiles.
4. Overhead water tanks.
5. Bath and sink units.
6. Cistern hall floats.

7. Decorative laminates and mouldings.
8. Window and door frames and shutters for bathroom doors.
9. Lighting fixtures.
10. Electrical conduits.
11. Electrical insulators.
12. Pipes to carry cold waters.

1.2 Artificial Timbers

What is artificial Timber?

artificial timber is nothing but timber product manufactured scientifically in factories. Because of its scientific nature, it is stronger and durable than ordinary timber materials. It also contains desired shape and size.



Different Types of artificial Timber

Following are the different form of artificial timber:

- Veneers
- Plywood
- Fiber boards
- Impreg timbers

- **Compreg timbers**
- **Hard boards**
- **Glulam**
- **Chip board**
- **Block board**
- **Flush door shutters**

Veneers

Veneers are nothing but thin layers of wood which are obtained by cutting the wood with sharp knife in rotary cutter.

In rotary cutter, the wood log is rotated against the sharp knife or saw and cuts it into thin sheets. These thin sheets are dried in kilns and finally veneers are obtained.

Veneers are used to manufacture different wood products like plywood, block boards etc.



Plywood

Ply means thin. Plywood is a board obtained by adding thin layers of wood or veneers on one above each other. The joining of successive layers is done by suitable adhesives.

The layers are glued and pressed with some pressure either in hot or cold condition. In hot conditions 150 to 200°C temperature is maintained and hydraulic press is used to press the layers. In cold conditions, room temperature is maintained and 0.7 to 1.4 N/mm² pressure is applied.

Plywood has so many uses. It is used for doors, partition walls, ceilings, paneling walls, formwork for concrete etc.

Due to its decorative appearance, it is used for buildings like theaters, auditoriums, temples, churches, restaurants etc. in architectural purpose.



Fiber Boards

Fiber boards are made of wood fibers, vegetable fibers etc. They are rigid boards and called as reconstructed wood.

The collected fibers are boiled in hot water and then transferred into closed vessel. Steam with low pressure is pumped into the vessel and pressure increased suddenly.

Due to sudden increment of pressure, the wood fibers explode and natural adhesive gets separated from the fibers. Then they are cleaned and spread on wire screen in the form of loose sheets. This matter is pressed in between steel plates and finally fiber boards are obtained.

Fiber boards are used for several purposes in construction industry such as for wall paneling, ceilings, partitions, flush doors, flooring material etc. They are also used as sound insulating material.



Impreg Timbers

Impreg timber is a timber covered fully or partly with resin. Thin layers of wood or veneers are taken and dipped in resin solution. Generally used resin is phenol formaldehyde.

The resin solution fills up the voids in the wood and consolidated mass occurs. Then it is heated at 150 to 160°C and finally impreg timber develops. This is available in market with different names such as sungloss, sunmica, Formica etc.

Impreg timber has good resistance against moisture, weathering, acids and electricity. It is strong, durable and provides beautiful appearance. It is used form making wood molds, furniture, decorative products etc.



Compreg Timbers

It is similar to impreg timber but in this case, the timber is cured under pressure conditions. So, it is more strengthened than impreg timber. Its specific gravity lies from 1.30 to 1.35.



Hard Boards

Hard board is usually 3 mm thick and made from wood pulp. Wood pulp is compressed with some pressure and made into solid boards. The top surface of board is smooth and hard while the bottom surface is rough.

Hard boards are generally classified as three types as follows:

Types	Density (kg/m ³)	Available thickness (mm)
Medium	480 - 800	6,8,10,12
Normal	800-1200	3,4,5,6,9,12
Tempered	>1200	3,4,5,6,9,12



Glulam

Glulam means glued and laminated wood. Solid wood veneers are glued to form sheets and then laminated with suitable resins.

This type of sheet is very much suitable in the construction of chemical factories, long span roofs in sports stadium, indoor swimming pools etc. Curved wood structures can also be constructed using glulam sheets.



Chip Board

Chip boards are another type of industrial timber which are made of wood particles or rice husk ash or bagasse. These are dissolved in resins for some time and heated. After then it is pressed with some pressure and boards are made. These are also called particle boards.



Block Board

Block board is a board containing core made of wood strips. The wood strips are generally obtained from the leftovers from solid timber conversion etc. These strips are glued and made into solid form.

Veneers are used as faces to cover this solid core. The width of core should not exceed 25mm. If the width of core is less than 7mm then it is called as lamin board.

Block boards are generally used for partitions, paneling, marine and river crafts, railway carriages etc.



Flush Door Shutters



Flush door shutters made in factories are widely using nowadays. They are generally available with 25mm, 30mm or 35mm thicknesses. Factory made flush board shutters are of different types such as cellular core, hollow core, block board core etc.

1.3 Miscellaneous materials

Acoustic Material

When the sound intensity is more, then it gives the great trouble or nuisance to the particular area like auditorium, cinema hall, studio, recreation center, entertainment hall, college reading hall. Hence it is very important to make that area or room to be sound proof by using a suitable material called as 'Acoustic material'. It is measured in decibels (db).

Acoustic material play a vital role in the various area of building construction. In studio, class room, reading hall, cinema theatre, more concentration is required to listen, hence the acoustics treatment is provided so as to control the outside as well as inside sound of the various building until such that sound will be audible without any nuisance or disturbance.

Types of Acoustic Material

- Acoustic plaster.
- Acoustic tiles.
- Perforated plywood.

- Fibrous plaster.
- Staw board.
- Pulp board.
- Compressed fibre board.
- Hair felt.
- Cork board slabs.
- Foam glass.
- Asbestos cement boards.
- Thermocoal.
- Foam plastic.
- Chip boards.
- Gasket cork sheet.
- Hair felt.
- Acoustic foam.

Properties of Acoustic Material

1. Sound energy is captured and adsorbed.
2. It has a low reflection and high absorption of sound.
3. Higher density improves the sound absorption efficiency at lower frequencies.
4. Higher density material help to maintain a low flammability performance. Hence acoustic material should have higher density.
5. It controls the sound and noise levels from machinery and other sources for environmental amelioration and regulatory compliance.
6. Acoustic material reduces the energy of sound waves as they pass through.
7. It suppresses echoes, reverberation, resonance and reflection.

Uses of Acoustic Material

1. Acoustic materials can be used for noise reduction and noise absorption.
2. It makes the sound more audible which is clear to listen without any disturbances.
3. It suppresses echoes, reverberation, reflection and resonance.
4. Important specifications for noise reduction and noise absorption products include noise attenuation and noise reduction coefficient.
5. A vinyl acoustic barrier blocks controls airborne noise (street traffic, voices, music) from passing through a wall ceiling or floor.
6. Acoustic foam and acoustic ceiling tiles absorb sound so as to minimize echo and reverberation within a room.
7. Sound proof doors and windows are designed to reduce the transmission of sound.
8. Building techniques such as double wall construction or cavity wall construction and staggering wall studs can improve the sound proofing of a room.
9. A sound proof wall (treated by a accurate material) can incorporate sound proofing and acoustic materials to meet desired sound transmission class (STC) values.

What Are The Different Types Of Cladding?



Cladding is a vital component in both commercial and domestic buildings to guarantee not only durability but also aesthetics. While cladding is capable of transforming the appearance of any property, its primary responsibility is to provide a protective layer to the underlying structure. It prevents potentially harmful external elements such as adverse weather conditions from causing structural damage, therefore, extending the longevity of the building.

What Are The Different Types Of Cladding: The 9 Systems Available Through enlisting the help of professional fitters, the installation of cladding is a relatively simple, straightforward project. Taking into consideration the size of the building and the overall complexity of the job, cladding can be installed in as little as a day. Once installed, systems require very little maintenance which makes them an incredibly reliable and cost-effective option for property owners. In the unlikely event of any damage to your panels, for instance, dents and scratches due to wear and tear, [cladding repairs](#) can be completed quickly causing minimal disruption to daily operations.

1. Timber Cladding

Timber remains to be one of the most aesthetically pleasing of all cladding types. Commonly installed in long, narrow boards that can be

fitted horizontally, vertically or diagonally, the outcome of timber cladding can be entirely customised to achieve the decorative finish you require. As timber is an organic source of material, every panel will be unique featuring a one-of-a-kind grain patterning that cannot be replicated, making your building stand out from the crowd.



2. Stone Cladding

Unlike other cladding types, a stone finish is more commonly a feature in domestic properties as opposed to commercial. Stone is perfect for providing homes with an elegant, luxurious exterior with a traditional “country home” feel. While natural stone cladding can be installed, it does come alongside an expensive price tag which means that many opt for its simulated alternatives. Simulated stone is ideal for lowering costs without compromising on aesthetics and durability.

Stone cladding is incredibly easy to maintain and can be cleaned through DIY methods. For more information on how to care for stone cladding, take a look at [Persian Tile](#).

3. Vinyl Cladding

Vinyl cladding is ideal for those looking for a contemporary, modern material that is available in an array of different colours. As vinyl remains one of the cheapest cladding materials and comes alongside proven energy efficiency, not only can it save you money during the

installation process but also in the future. Panels can even be fitted with an additional layer of insulation that forms a temperature-controlling blanket over your property, keeping the space warm in the Winter and cool in the Summer.



4. Weatherboard Cladding

When researching the different types of cladding, many assume that timber and weatherboard systems are the same; however, this isn't the case. While weatherboard cladding is constructed using timber, the wood has been reconstituted instead of using authentic hardwood.

5. Glass Cladding

Many world-famous buildings across the globe including the [Gherkin in London](#) and [Louvre in Paris](#) utilise glass cladding for their recognisable exterior. Commonly used in commercial properties, glass cladding is highly effective in creating an instant modern appearance that most definitely stands out from the crowd.



6. Brick Cladding

Brick cladding is fantastic if you are hoping to achieve a traditional appearance similar to stone; however, aim to add a modern patterned twist. Using different coloured bricks, the installation of your cladding can be altered to produce a particular pattern or design. Unlike regular bricks that are manufactured specially to build walls, cladding bricks are constructed using lightweight materials and in a variety of different colours.

7. Fibre Cement Cladding

Fibre cement is a composite material that can be used for both interior and exterior cladding. A composite material, by definition, is any material that has been created using two or more constituent elements to produce a new material that has unique characteristics. Materials used to create fibre cement include cement, sand, filler and cellulose, an organic compound found in plant cell walls.

Fibre cement cladding continues to rise in popularity due to its guaranteed longevity and protection against elements such as fire, adverse weather, heavy impact and insects. It is quick to install due to its lightweight features and once set, will not change when exposed to excessive heat or exposure to moisture.



8. Metal Cladding

While metal cladding may not be able to achieve the eye-catching, unique aesthetics that other materials can, it is extremely durable making it the ideal option for industrial buildings. The most popular materials used for metal cladding include steel and aluminium; both of which come alongside their own individual benefits and drawbacks.

Plaster Board

A sheet of plasterboard consists of a hardened gypsum core between two layers of paper.

The face side front paper is a strong, smooth finished paper impregnated with gypsum crystals to aid bonding of the plaster coat (or skim), while the reverse is covered in a rougher 'natural' paper

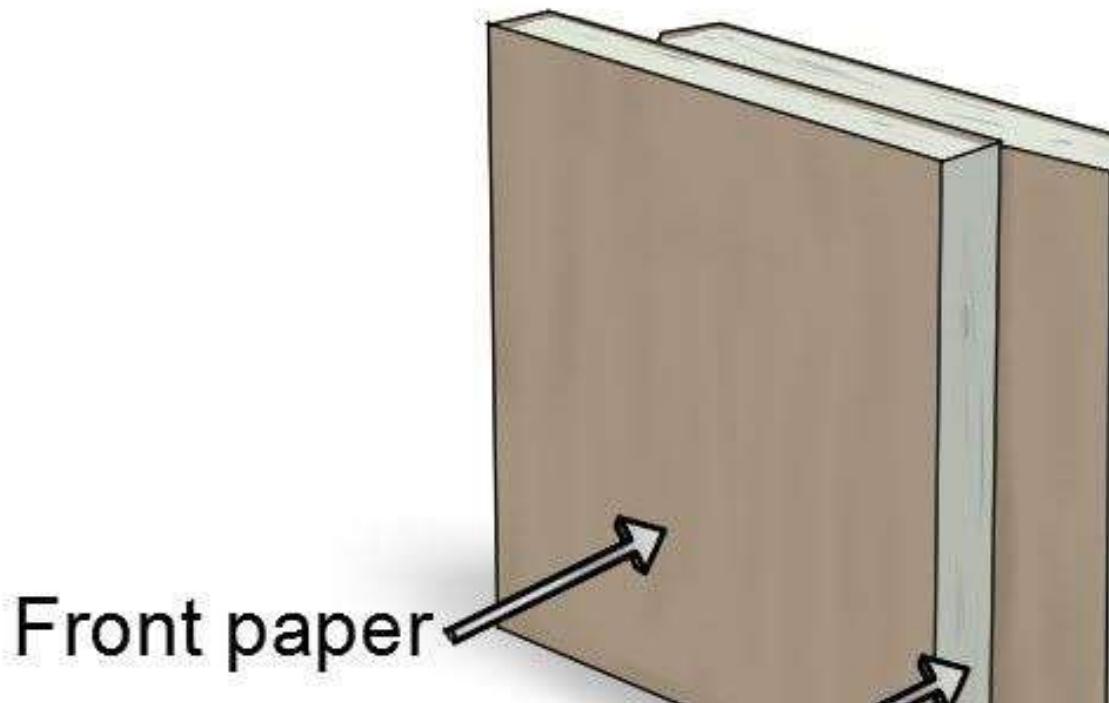

Micro Silica

Silica fume, also known as microsilica, is an amorphous polymorph of silicon dioxide, silica. It is an ultrafine powder collected as a by-product of the silicon and ferrosilicon alloy production and consists of spherical particles with an average particle diameter of 150 nm.

Several materials have recently been used for the improvement of concrete properties. Microsilica or silica fume is an excellent admixture for concrete as it leads to better engineering properties. It reduces thermal cracking, improves durability, and increases strength.

Artificial sand

Artificial sand is one of the building sands, which refers to rock particles with a particle size of less than 4.75 mm and is made by **artificial** crushing and sieving after soil removal treatment.

Prefabrication

❖ What is prefabrication

Prefabrication is the practice of assembling components of a structure in a factory or other manufacturing site, and transporting complete assemblies or sub-assemblies to the construction site where the structure is to be located.

❖ necessity and scope of prefabrication of buildings

With prefabrication, there is less risk for problems with dirt, moisture, and other environmental hazards because workers create sub-assemblies in factory-controlled environments. Recently, prefabricated materials and engineering have improved to make the structures and assemblies as strong as traditional buildings.

Without difficulty, workers disassemble and relocate sub-assemblies to different sites. General contractors and owners are leaning more towards prefabricated methods of construction because it provides flexibility without constraining creativity. Opportunities are endless because prefabricated and modular construction allows for the flexibility in the structure design.

Prefabrication is a modern construction process that is growing in popularity. In the construction industry, there are innovative ideas and approaches that increase productivity and cost savings. All in all, prefabrication enables time and cost savings, quality control, and a more eco-friendly construction process.

❖ history of prefabrication

In 19th century Australia a large number of prefabricated houses were imported from the United Kingdom. The method was widely used in the construction of prefabricated housing in the 20th century, such as in the United Kingdom as temporary housing for thousands of urban families "bombed out" during World War II.

❖ Current uses of prefabrication

Prefabrication has become widely used in the assembly of aircraft and spacecraft, with components such as wings and fuselage sections often being manufactured in different countries or states from the final assembly site. However, this is sometimes for political rather than commercial reasons, such as for Airbus.

Types of fabricated system

- **Modular:** three-dimensional components built almost entirely in a factory environment and delivered to the site for installation. ...
- **Panelized:** 2D panel homes will partially install in a factory environment. ...
- **Hybrid Prefab:** A combination of 2D panel and 3D modular construction.

Classification :

The Prefabrication is classified as follow from the view of degree of Precast construction.

1. Small prefabrication
2. Medium Prefabrication
3. Large Prefabrication
4. Cast in Site Prefabrication
5. Off-Site (or) factory Prefabrication
6. Open system of prefabrication
7. Closed system of prefabrication
8. Partial prefabrication
9. Total prefabrication

❖ Small Prefabrication :

The first 3 types are mainly classified according to their degree of precast Elements using in that construction for eg.:brick is a small unit precast and used in building.

This is called as small prefabrication. That the degree of precast element is very low. Medium Prefabrication :

Suppose the roofing systems and horizontal members are provided with pretested elements those construction are known as medium prefabricated construction here th degree of precast elements are moderate.

❖ Large Prefabrication :

In large prefabrication most of the members like wall panels, roofing / flooring Systems, beams and columns are prefabricated. Here degree of precast elements are high.

❖ Cast – in – site prefabrication : OFF – site (factory) prefabrication : One of the main factor which affect the factory prefabrication is transport.

The width of mad walls, mode of transport, vehicles are the factors which prefabrication is to be done on site on factory.

Suppose the factory situated at a long distance from the construction site and the vehicle have to cross a congested traffic with heavy weighed elements the cost in side prefabrication is preferred even though the same condition are the cast in site prefabrication is preferred only when number of houses and more for small elements the conveyance is easier with normal type of lorry and trailers. Therefore we can adopt factory (or) OFF site prefabrication for this type of construction.

❖ Open system of prefabrication

In the total prefabrication systems, the space framers are casted as a single unit and erected at the site. The wall fitting and other fixing are done on site. This type of construction is known as open system of prefabrication.

❖ Closed system of prefabrication :

In this system the whole things are casted with fixings and erected on site.

❖ Partial prefabrication :

In this method of construction the building element (mostly horizontal) required are precast and then erected. Since the casting of horizontal elements (roof/ floor) often take there time due to erection of form work the completion of the building is delayed and hence this method is restored. In most of the building sites this method is popular more. Son in industrial buildings where the elements have longer spans. Use of double tees, channel units, cored slabs, hyperboloid shell etc., are some of the horizontal elements.

Advantages And Disadvantages

Advantages:

1. Saving in cost, material, time & manpower.
2. Shuttering and scaffolding is not necessary.
3. Installation of building services and finishes can be done immediately.
4. Independent of weather condition.
5. Components produced at close supervision .so quality is good
6. Clean and dry work at site.
7. Possibility of alterations and reuse
8. Correct shape and dimensions and sharp edges are maintained.
9. Very thin sections can be entirely precast with precision.

Disadvantages:

- Handling and transportation may cause breakages of members during the transit and extra provision is to be made.
- Difficulty in connecting precast units so as to produce same effect as monolithic. This leads to non-monolithic construction.
- They are to be exactly placed in position, otherwise the loads coming on them are likely to get changed and the member may be affected.
- Disadvantages:
 - High transport cost
 - Need of erection equipment
 - Skilled labour and supervision is required.

Prefabricated Slab To Beam Connection

Types of Precast Components in a Building

- • **Types of Precast Components in a Building:**
- • **Precast Beams:**
- • **Precast Columns:**
- • **Precast floor slabs:**
- • **Precast walls:**
- • **Precast staircases:**

MODULAR COORDINATION

Modular coordination is a concept of coordination of dimension and space, in which buildings and components are dimensioned and positioned in a term of a basic unit or module, known as '1M' which is equivalent to 100 mm. • It is internationally accepted by the International Organization for Standardization (ISO) and many other countries. • Thus, the modular coordination can facilitate the achievement of greater productivity in the building industry by virtue of its ability to discipline the dimensional and spatial coordination of a building and its components

Earthquake Resistant Construction

Building Configuration: This term defines a building's size and shape, and structural and nonstructural elements. Building configuration determines the way seismic forces are distributed within the structure, their relative magnitude, and problematic design concerns.

- *Regular Configuration* buildings have Shear Walls or Moment-Resistant Frames or Braced Frames and generally have:
 - Low Height to Base Ratios
 - Equal Floor Heights
 - Symmetrical Plans
 - Uniform Sections and Elevations
 - Maximum Torsional Resistance
 - Short Spans and Redundancy
 - Direct Load Paths
- *Irregular Configuration* buildings are those that differ from the "Regular" definition and have problematic stress concentrations and torsion.

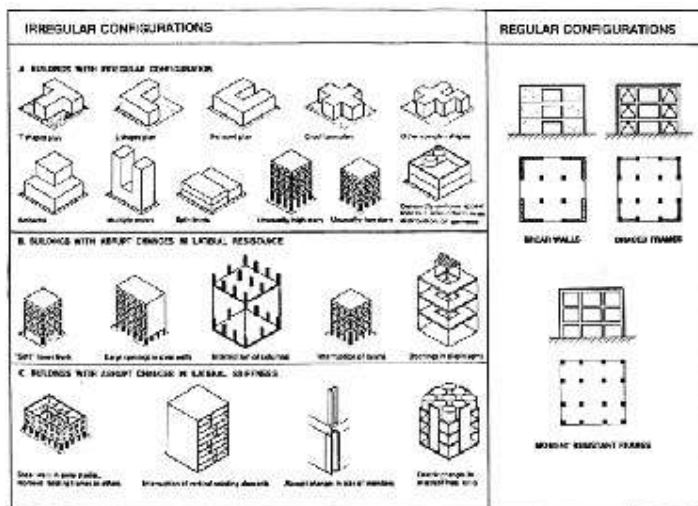

[View enlarged illustration](#)

Buildings seldom overturn—they fall apart or "pancake"

Soft First Story is a discontinuity of strength and stiffness for lateral load at the ground level. *Discontinuous Shear Walls* do not line up consistently one upon the other causing "soft" levels.

Variation in *Perimeter Strength* and *Stiffness* such as an open front on the ground level usually causes eccentricity or torsion.

Reentrant Corners in the shapes of **H**, **L**, **T**, **U**, **+**, or **||** develop stress concentration at the reentrant corner and torsion. Seismic designs should adequately separate reentrant corners or strengthen them.

Knowledge of the building's period, torsion, damping, ductility, strength, stiffness, and configuration can help one determine the most appropriate seismic design devices and mitigation strategies to employ.

Types Of Lateral Force-Resisting Systems In Commercial Buildings

Every structure must be designed and constructed to withstand lateral loads and horizontal loads. Structures are braced against lateral and horizontal forces in several ways. Bracing is installed perpendicular to the direction of the potential force. Bracing is often installed in every direction because forces can come from every direction.

The most common bracing methods for resisting lateral forces in commercial buildings include moment frames, shear walls, and braced frames. These are vertical elements that transfer lateral loads, including wind, seismic forces, and stability forces through floor or roof diaphragms to the building's foundation. They help keep a structure from blowing over or collapsing.

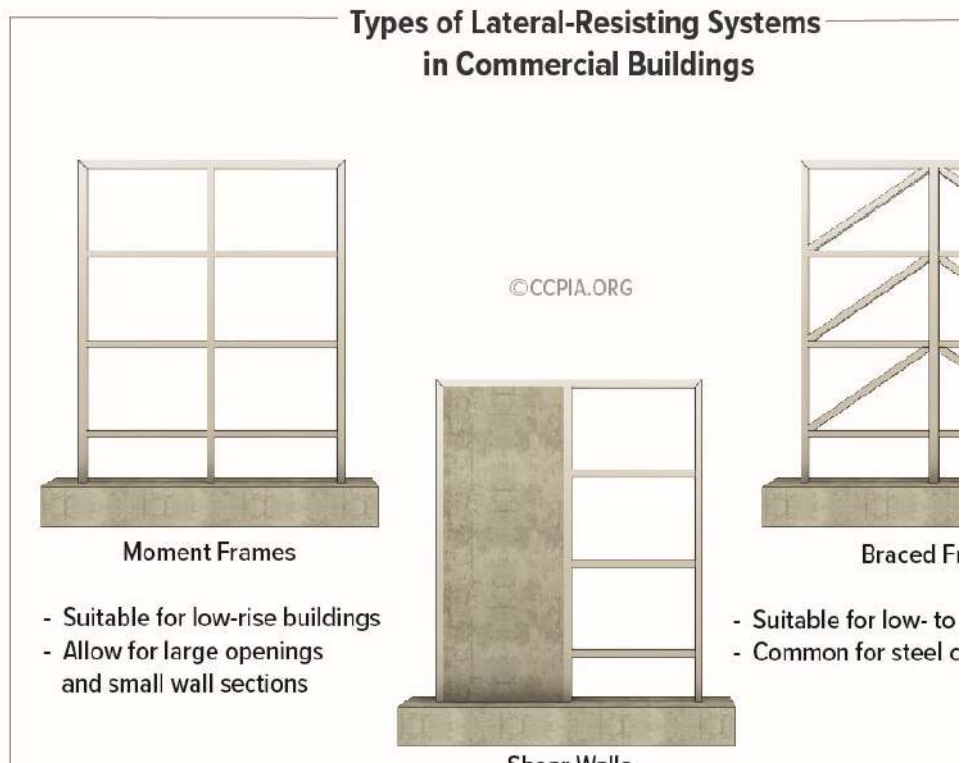

Moment Frames

Steel moment frames are vertical frames consisting of traditional beams and columns that are typically connected by bolts and/or welds. They are more flexible than shear walls and brace frame structures. The rigid connection points permit the frame to resist lateral loads through the flexural strength (bending) and continuity of its beams and columns, such that moments are transferred from beams to columns at the connection points. A moment frame will not move laterally without bending the beams or columns. The three main types of connections are bolted, welded, and proprietary, and there are several variations of each. Concrete frames are also commonly considered moment frames because of their similar continuity.

How Moment Frames Work

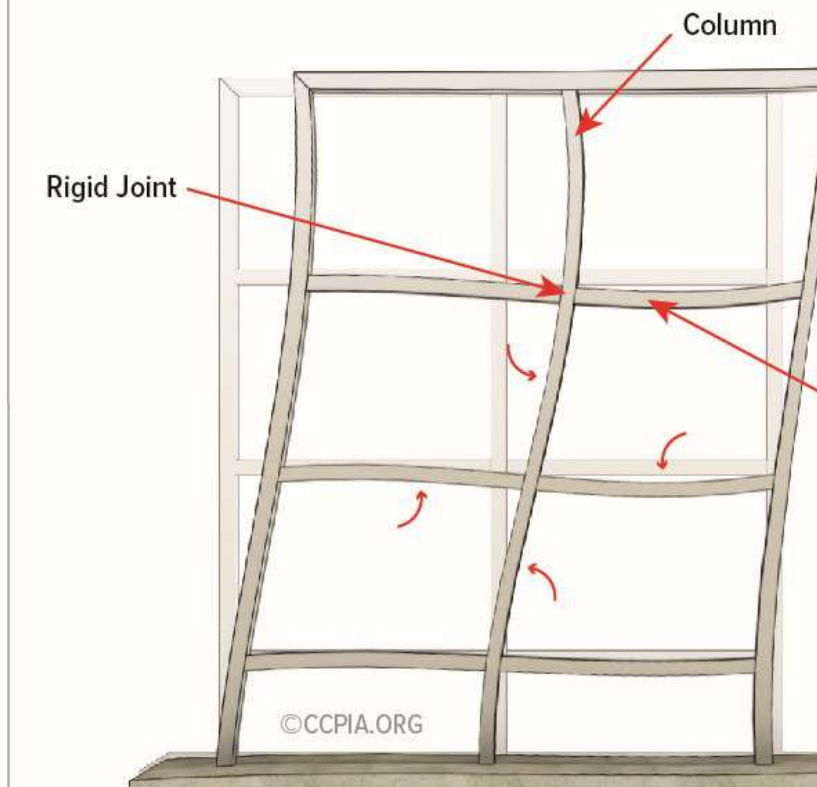

Moment frames have several applications in single-story and multi-story commercial buildings, but they're used primarily in low-rise buildings. Moment frames allow for larger openings and small wall sections while still supporting required loads and resisting various forces.

Some of the typical applications include:

- structural steel buildings;
- large building entryways;
- walls with large openings; and
- tuck-under parking.



Large building entryway moment frame

The three types of moment frames include ordinary moment frames (OMF), intermediate moment frames (IMF), and special moment frames (SMF).

They are classified for use based on zones of seismic activity, such that:

- OMFs are usually used in zones with no or low seismic activity;
- IMFs are usually used in low- to mid-seismic activity regions; and
- SPFs are usually used in mid- to high-seismic activity regions.

Moment frames that are used in zones with seismic activity must have pre-qualified connections per the American Institute of Steel Construction (AISC), or, in some cases, be verified through testing. Additionally, they must be expected to withstand inelastic deformations and sustain a specific inter-story drift angle.

Shear Walls

A shear wall is a structural member that resists cracking through in-plane shear, such that ground movement enters the building and creates inertial forces that move the floor diaphragms. Shear walls resist this movement, and the forces are transmitted back down to the diaphragm below or to the foundation. It essentially acts as a vertically spanning beam to resist lateral forces. Shear walls typically span from the foundation to the top of a building. They also perform well in areas with seismic activity.

Shear walls are typically constructed of concrete, masonry, cold-formed steel, or wood framing. Shear walls are important in medium- to high-rise buildings, or any building located in high wind or seismic activity areas. Many homes have shear walls on the exterior perimeter.

The strength and stiffness of a building depend on the shape and position of the shear wall. Common positioning includes the building's perimeter or the center of a building

encasing an elevator shaft or stairwell. The latter is referred to as a shear core. Other shear wall shapes include a rectangle, L-shape, and C-shape.

A shear wall with openings is referred to as coupled shear walls. In this case, the shear wall acts as an individual wall section, and the slabs above and below the openings act as a tie beam that distributes the load. The symmetrical location of shear walls in buildings is desirable.



Braced Frames

Braced frames are common in steel construction. They use diagonal and/or triangulated steel beams or cables to resist lateral forces. Resistance is provided by vertical bracing or horizontal bracing. Vertical bracing between structural columns transfers lateral forces to ground level. Horizontal bracing at each floor or the roof transfers lateral forces to the vertical bracing, and then it's transferred to ground level. However, the floor system is usually a sufficient diaphragm without the need for additional steel bracing. Braced frames are suitable for multi-story buildings in the low- to mid-rise range.

The two main types of braced frames are concentric bracing and eccentric bracing. Concentrically braced frames are typically triangulated and connected at the endpoints of other framing members (joints) to develop a truss. A few common configurations include a cross-brace (X-brace), inverted V-brace (chevron brace), and a single diagonal brace. Eccentrically braced systems utilize diagonal braces with one or two ends deliberately offset to the supporting member such that the bracing isn't centered. The gap between the offset bracing is referred to as the structural fuse region, and it's designed to dissipate a lot of energy during an earthquake event.

Types of Braced Frames in Commercial Buildings

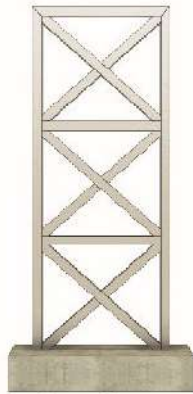

Cross-Brace

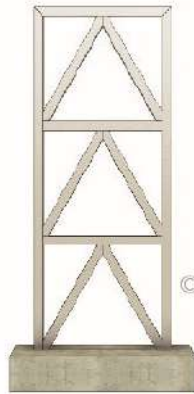

Inverted V-Brace

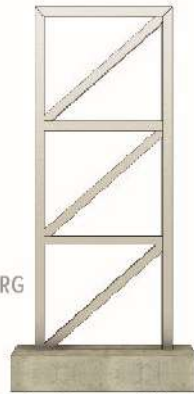

Single Diagonal Brace

Structural
Fuse
Region

©CCPIA.ORG

- [What are Horizontal Bands in Masonry Buildings?](#)
- [Location of Horizontal Bands in Buildings](#)
- [Types of Horizontal Bands](#)
 - [Plinth Band](#)
 - [Lintel Band](#)
 - [Roof Band](#)
 - [Gable Band](#)
- [Design Details of Horizontal Band](#)

What are Horizontal Bands in Masonry Buildings?

The horizontal band can be defined as a method of reinforcing the masonry buildings by providing bands with higher tension strength. This is enabled in areas where two structural elements of a building meet, so that a connection is formed all together and they would behave like a single unit.

Horizontal bands can be also termed as seismic bands which consist of reinforced concrete running flat throughout all the external and internal masonry wall elements.

Location of Horizontal Bands in Buildings

Horizontal bands are implemented at the following levels:

- At the plinth level of the building
- At the levels of lintels (i.e. at door and windows)
- At the ceiling levels

The requirement of horizontal bands in roof level is not necessary if the roofs are [reinforced concrete or reinforced masonry slab](#) units given that they have a depth of 2/3rd wall thickness.

Types of Horizontal Bands

Based on the area where a horizontal band is provided, it can be classified as follows

- Gable Band
- Roof Band
- Lintel Band
- Plinth Band

The figure below depicts the important elements of an earthquake resistant masonry buildings.

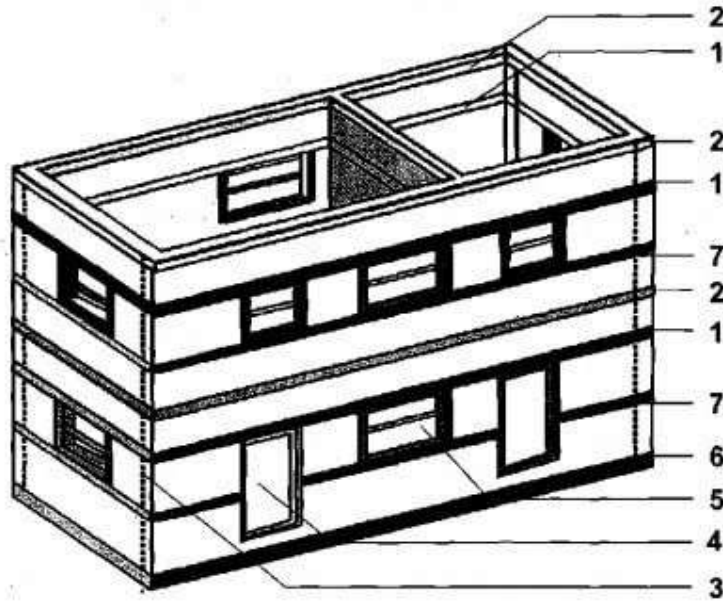

Fig.1: Representation of Horizontal Bands In a Masonry Building, where 1 -Lintel Band, 2- Roof Band, 3- Vertical Reinforcing Band, 4-Door, 5-Window,6- Plinth Band, 7 – Window Still Band

A brief explanation on each individual bands are given below:

Plinth Band

This type of horizontal bands is essential in those areas where the soil on which the building has to be constructed is weak. The soil will be soft with uneven properties. This [problem is mainly found in soils](#) found in hilly areas. This band is hence not necessary if we have a stronger soil and substructure.

Lintel Band

As the names tells these are horizontal bands provided at the lintel level. And it is provided in almost all buildings. Under the action of earthquake ground motion, the lintel band is subjected to constant bending as well as pulling as shown in figure 2. Hence the construction of lintel band has to done with special care and supervision.

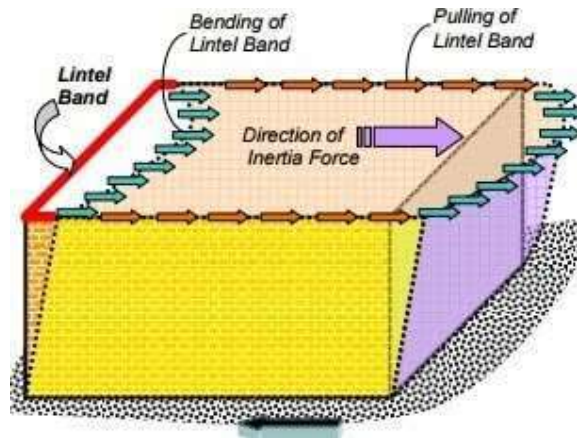

Fig.2: Lintel Band Under Seismic Action

Roof Band

These bands are mainly employed in [buildings with roofs made of flat timber](#) or CGI sheets. If the building roof is made of reinforced concrete slabs or brick roofs as mentioned before, there is no need of these bands. As R.C slabs itself behave as a horizontal band.

Gable Band

Those buildings that have sloped roof i.e. truss construction, gable bands are necessary. Now the incorporation of Gable band is not shown in the figure as the building have a flat roof. When the [roof construction is by using a truss](#), the requirement of gable band comes into play.

Design Details of Horizontal Band

The recommendations on the design of horizontal bands are provided by IS:4326-1996 Code of practice. This is applicable for the buildings from brick or concrete block walls and also those with RC flat slab roofs. The dimension of the horizontal band and the reinforcement details depend upon the length of the walls which is between the perpendicular cross walls.

The details of the dimension of the band and its reinforcement details with respect to the wall thickness for buildings with different functionality is shown in table-1. These recommendations are for buildings located in Zone 5, as per Indian code.

Table-1: Size of Horizontal Band for Different Buildings

Internal length of wall	Buildings of all types i.e., Residential buildings & Public Buildings (Schools, Hospitals, Meeting Halls, Anganwadis, etc.)		
	Size of the band	No. of Bars	Dia (mm)
5 m or, less	10 cm x wall width	2	10
6 m	10 cm x wall width	2	12
7 m	15 cm x wall width	4	10
8 m	15 cm x wall width	4	12

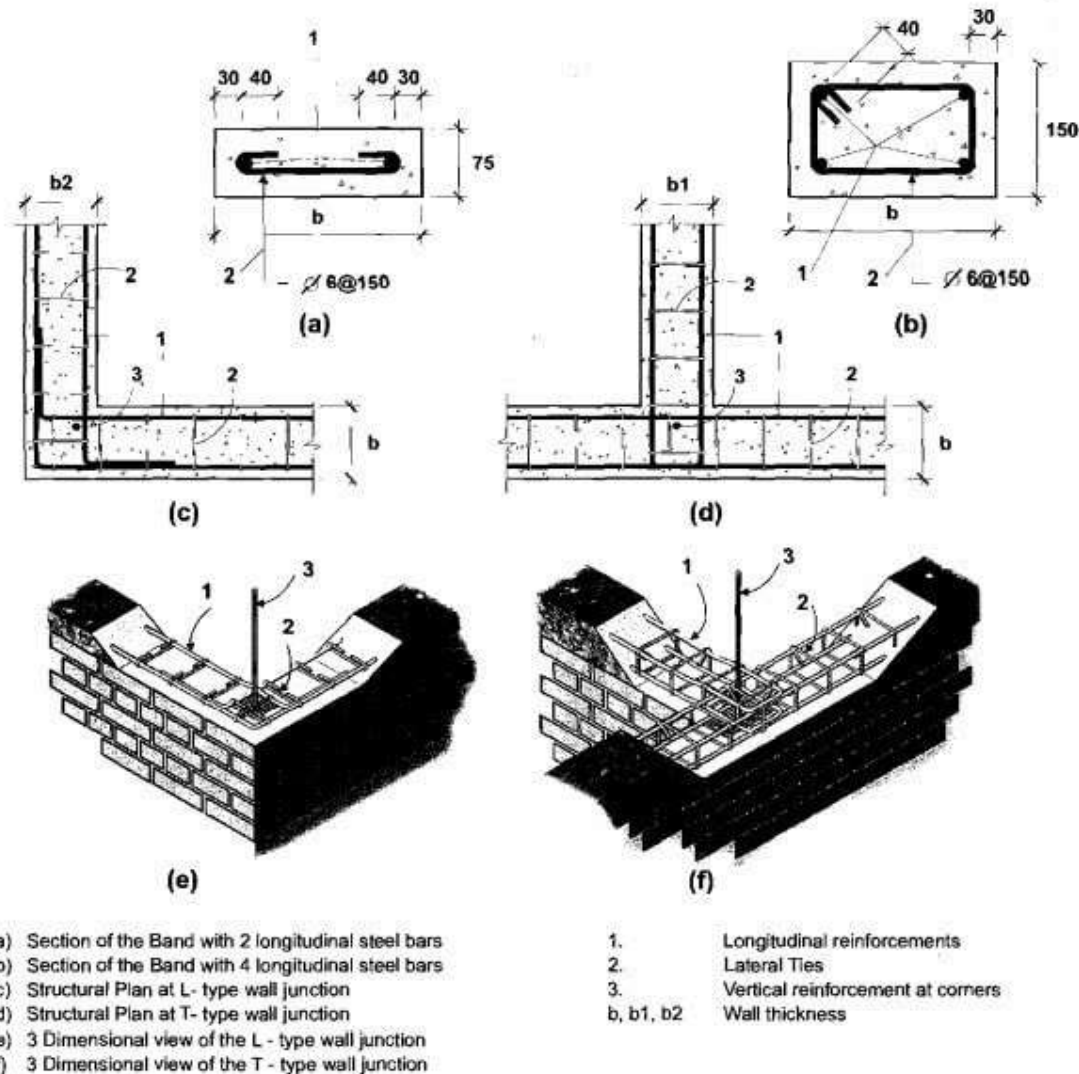

Fig.3: Reinforcement Details of Horizontal Bands in Masonry Walls

The details of sizes and recommendations of bands are provided by Indian Standards IS 4326-1993 and IS 13828(1993). The bands used can be either wooden material or reinforced concrete. R.C bands are the best ones. A

minimum of 75mm x 38mm is used for runners and 50mm x 30mm minimum for spacers as shown in figure 4.

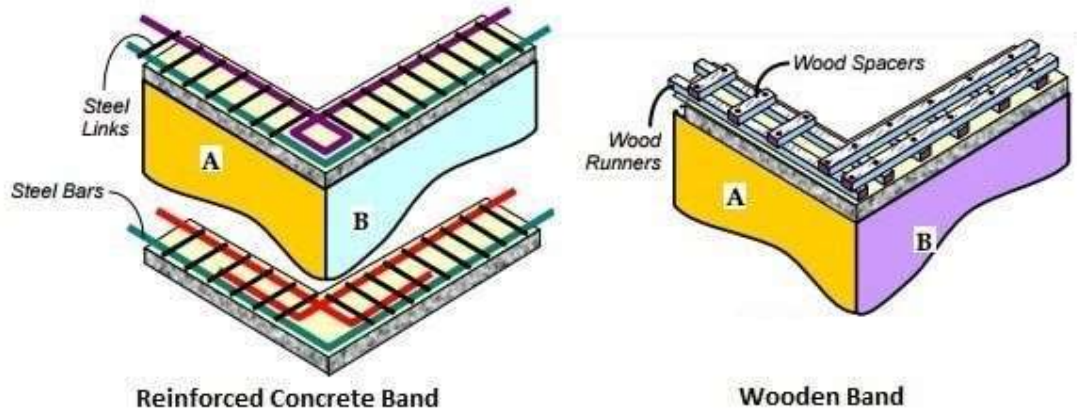

Fig.4: Reinforced Concrete Band and Wooden Band

When reinforced concrete bars are used , at least 75mm thickness has to be provided. A minimum of two bars of 8mm diameter is required that is tied across with the help of steel links. The steel links , with a minimum of 6mm diameter with a spacing of 150mm center to center distance, is incorporated as shown in figure 4.

Seismic Retrofitting Techniques for Concrete

Structures:

Seismic Retrofitting Techniques are required for concrete constructions which are vulnerable to damage and failures by seismic forces. In the past thirty years, moderate to severe earthquakes occurs around the world every year. Such events lead to damage to the concrete structures as well as failures. Thus the aim is to Focus on a few specific procedures which may improve the practice for the evaluation of seismic vulnerability of existing reinforced concrete buildings of more importance and for their seismic retrofitting by means of various innovative techniques such as base isolation and mass reduction. So Seismic Retrofitting is a collection of mitigation technique for Earthquake engineering. It is of utmost importance for historic monuments, areas prone to severe earthquakes and tall or expensive structures. **Keywords:** Retrofitting, Base Isolation, Retrofitting Techniques, Jacketing, Earthquake Resistance

Introduction to Seismic Retrofitting Techniques:

- Earthquake creates great devastation in terms of life, money and failures of structures.
- Upgrading of certain building systems (existing structures) to make them more resistant to seismic activity (earthquake resistance) is really of more importance.
- Structures can be (a) Earthquake damaged, (b) Earthquake vulnerable
- Retrofitting proves to be a better economic consideration and immediate shelter to problems rather than replacement of building.

1.1 Seismic Retrofitting of Concrete Structures:

Definition: It is the modification of existing structures to make them more resistant to seismic activity, ground motion, or soil failure due to earthquakes. The retrofit techniques are also applicable for other natural hazards such as tropical cyclones, tornadoes, and severe winds from thunderstorms.

2. Classification of Retrofitting Techniques:

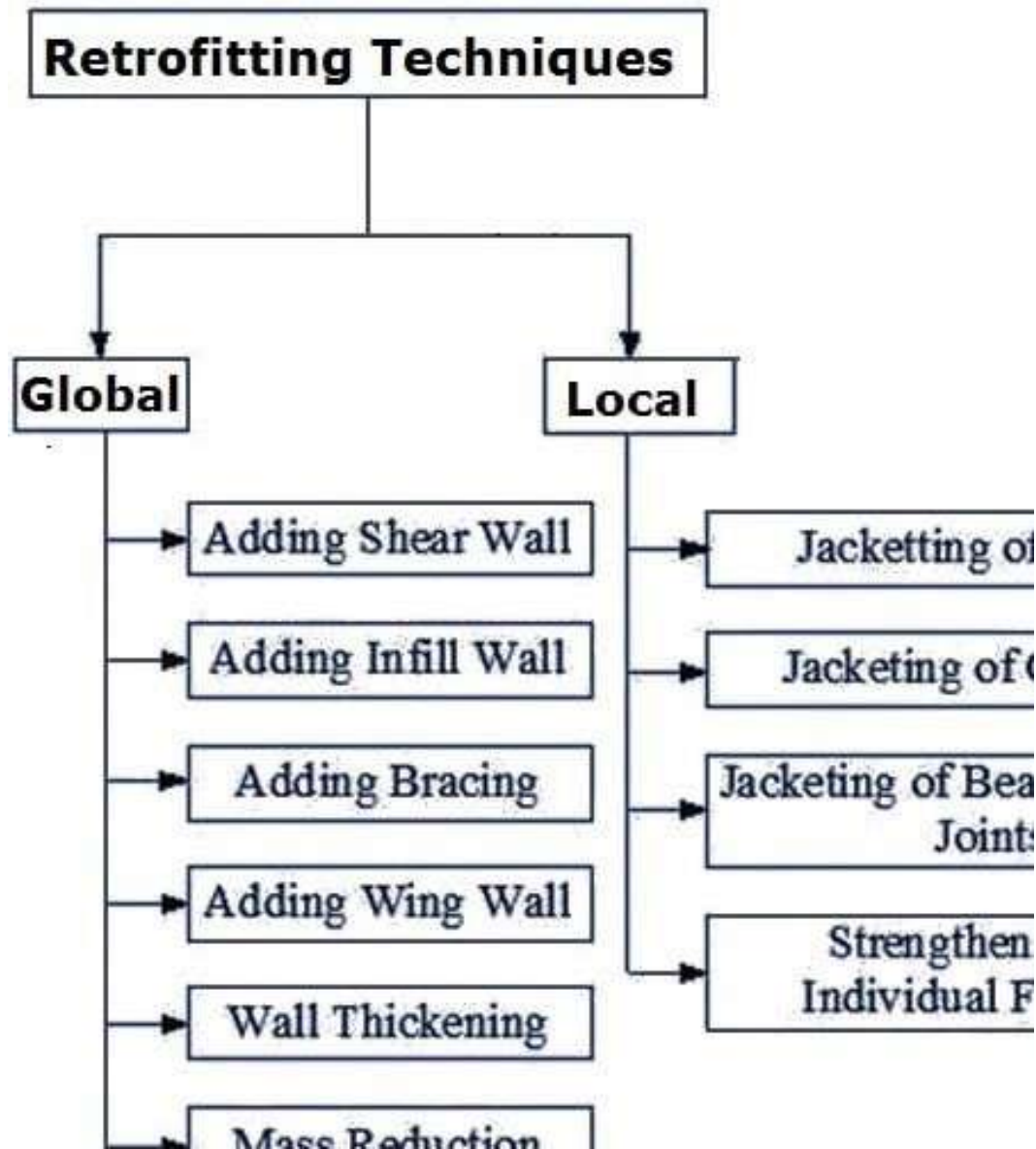

Fig 1: Retrofitting Techniques for Reinforced Concrete Structures

2.1 Adding New Shear Walls:

- Frequently used for retrofitting of non ductile reinforced concrete frame buildings.
- The added elements can be either cast-in-place or precast concrete elements.

- New elements preferably be placed at the exterior of the building.
- Not preferred in the interior of the structure to avoid interior mouldings.



Fig 2: Additional Shear Wall

2.2 Adding Steel Bracings

- An effective solution when large openings are required.
- Potential advantages due to higher strength and stiffness, opening for natural light can be provided, amount of work is less since foundation cost may be minimized and adds much less weight to the existing structure.

Adding STEEL Bracings:

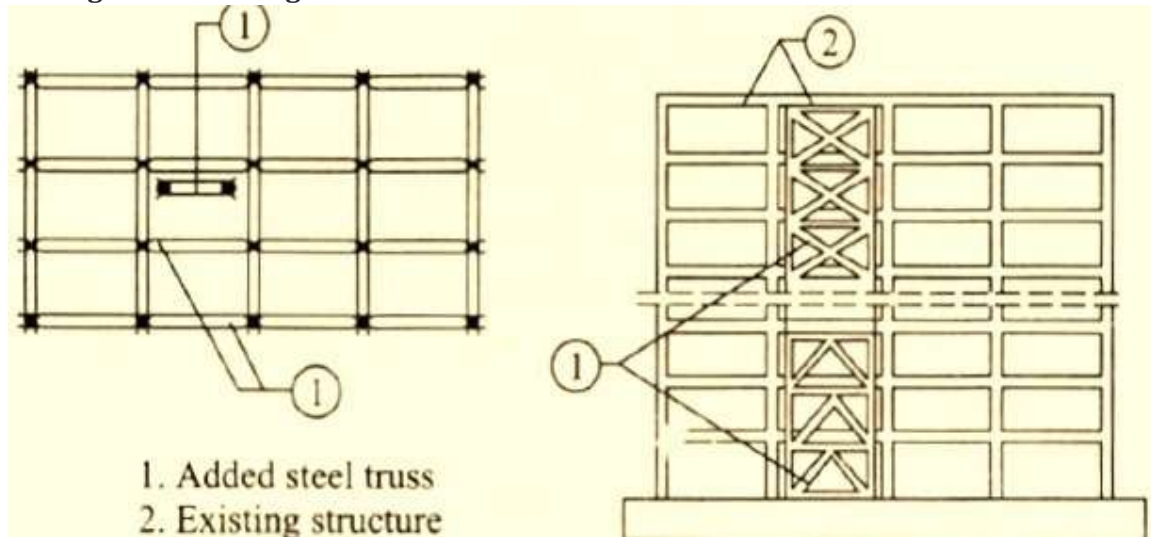
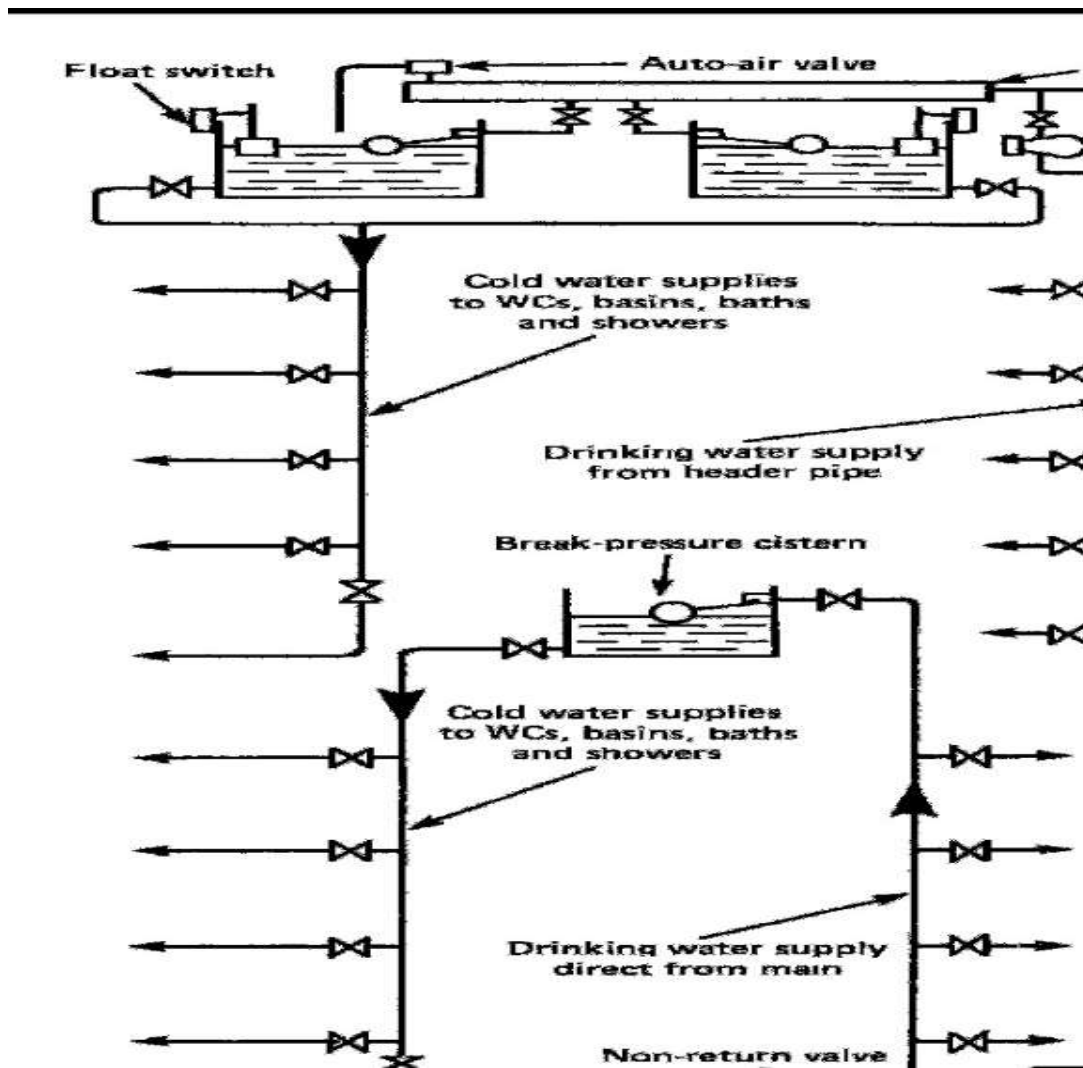
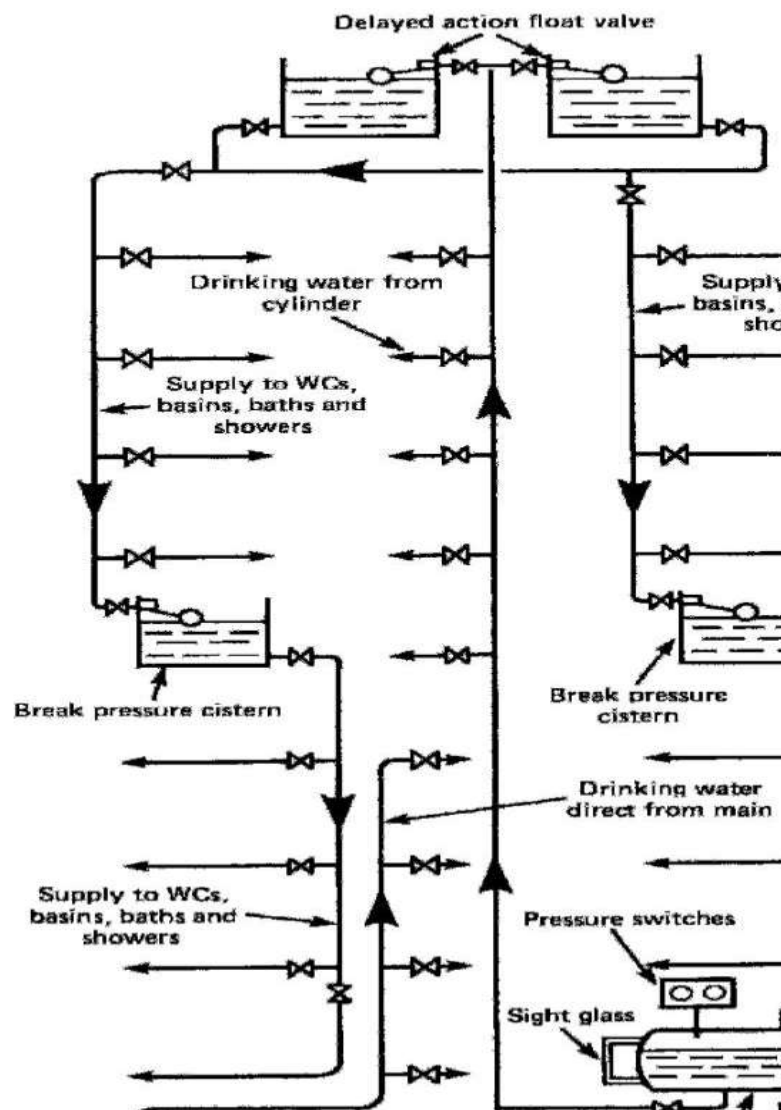

Fig 3: RC Building retrofitted by steel bracing

For medium and high rise buildings, there is often insufficient mains pressure to supply water directly to the upper floors. Boosting by pump from a break tank is therefore usually necessary and several more of these tanks may be required as the building rises, depending on the pump capacity. A break pressure cistern is also required on the down service to limit the head or pressure on the lower fittings to a maximum of 30 m (approx. 300 kPa). The drinking water header pipe or storage vessel supplies drinking water to the upper floors. As this empties and the water reaches a predetermined low level, the pipeline switch engages the duty pump. A float switch in the break tank protects the pumps from dry running if there is an interruption to mains supply. The various pipe sections are fitted with isolating valves to facilitate maintenance and repairs.



As an alternative to the drinking water header pipe, an auto-pneumatic cylinder may be used. Compressed air in the cylinder forces water up to the float valves and drinking water outlets on the upper floors. As the cylinder empties a low pressure switch engages the duty pump. When the pump has replenished the cylinder, a high pressure switch disengages the pump. In time, some air is absorbed by the water. As this occurs, a float switch detects the high water level in the cylinder and activates an air compressor to regulate the correct volume of air. Break pressure cisterns may be supplied either from the storage cisterns at roof level or from the rising main. A pressure reducing valve is sometimes used instead of a break pressure cistern.



Hot water supply – General principles for central plants-layout

The hot water from the boiler mixes directly with the water in the cylinder. If used in a 'soft' water area the boiler must be rust-proofed. This system is not suited to 'hard' waters, typical of those extracted from boreholes into chalk or limestone strata. When heated the calcium precipitates to line the boiler and primary pipework, eventually 'furring up' the system to render it ineffective and dangerous. The storage cylinder and associated pipework should be well insulated to reduce energy losses. If a towel rail is fitted, this may be supplied from the primary flow and return pipes

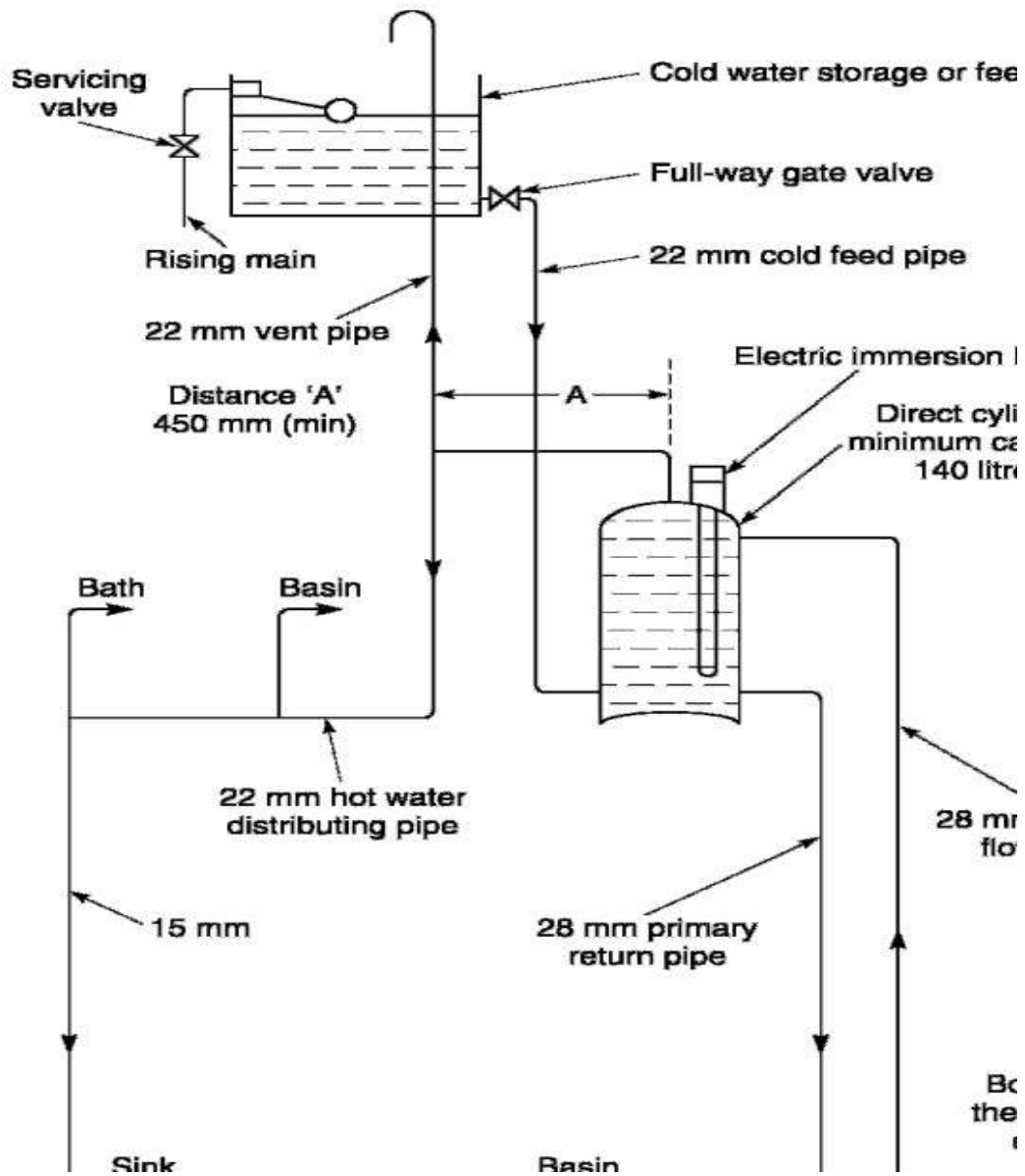

requirements in high rise buildings

The requirements of the planning and execution of electrical works of an ordinary building having ground plus one or two floors housing are quite different from those of a multistoried or high rise building. A building is classified as 'High Rise', if it has more than Four floors (Ground + 3 Floors) or height more than 15 meters. It can be regarded as a miniature township requiring entire range of civic services such as electric power from the electricity board, stand by / emergency power from diesel generator, water supplies for various applications, fire fighting system, elevator services, sanitation, recreation facilities, swimming pool, lighting for apartments as well as common areas etc.

A wiring diagram is a simple visual representation of the physical connections and physical layout of an electrical system or circuit. It shows how the electrical wires are interconnected and can also show where fixtures and components may be connected to the system

Types of Electrical Wiring

We know that electrical circuit is a closed path through which electricity flows from phase or hot wire to the device or apparatus and then back the source through neutral wire.

Along the way, the electricity path may consist of fixtures, switches, receptacles, junction boxes, etc. So, the wiring may be routed through these elements before actually making connections with apparatus or device.

Majorly, the wiring is divided into two types depending on the way the devices are powered or connected to the supply. They are:

- Parallel Wiring
- Series Wiring

In Parallel Wiring, several devices on the installation are powered on a single circuit. It is the most accepted wiring in homes and industries, in which devices are connected in parallel with the supply source as shown in figure.

In this, both phase (or hot) and neutral cables are routed through the electrical boxes (junction boxes) from which individual receptacles, fixtures, and devices are branched.

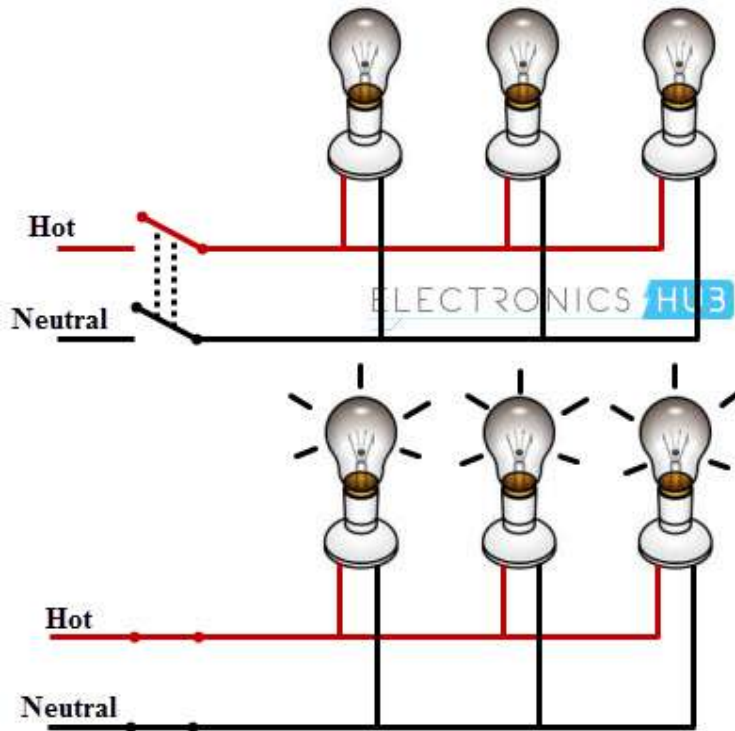

The Series Wiring is the rarely used wiring in which hot wire is routed through the several devices and then last device terminal is connected to the neutral wire. It is like an old Christmas lights or serial lights wiring in which one light burnout leads to the shutdown of the entire network.

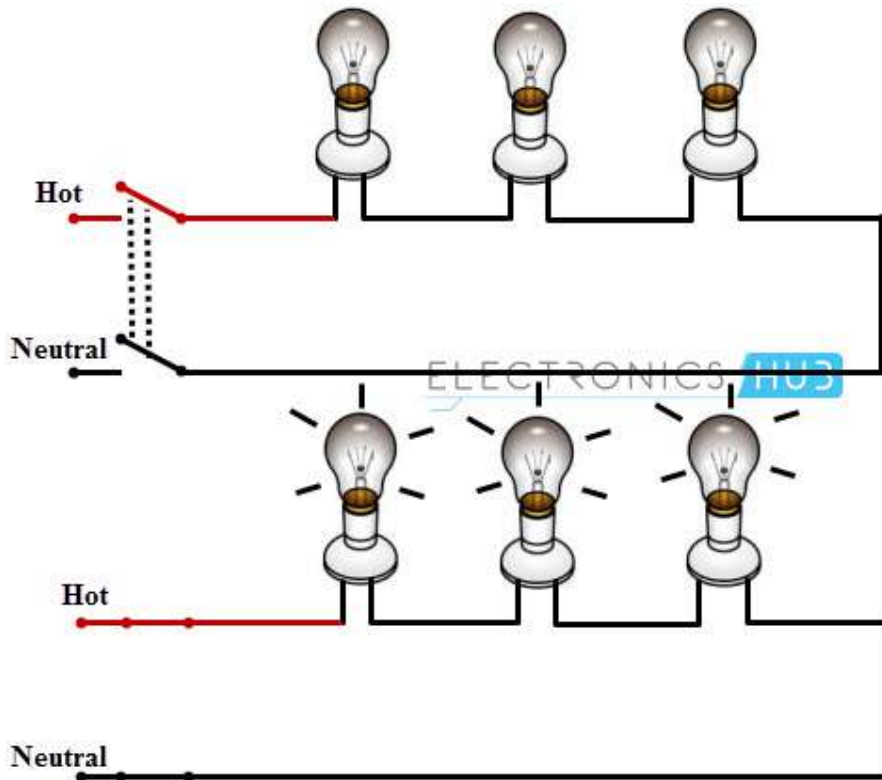

Examples of Electrical Wiring

For a better understanding of the wiring concept, here we are giving some examples of the wiring circuits, which are commonly used in our homes / offices.

Single Bulb (or any other load) Controlled by a One Way Switch

In this, hot wire is connected to the one terminal of the switch and other terminal of the switch is connected to the bulb positive terminal, then bulb negative terminal is connected to the neutral wire as shown in figure.

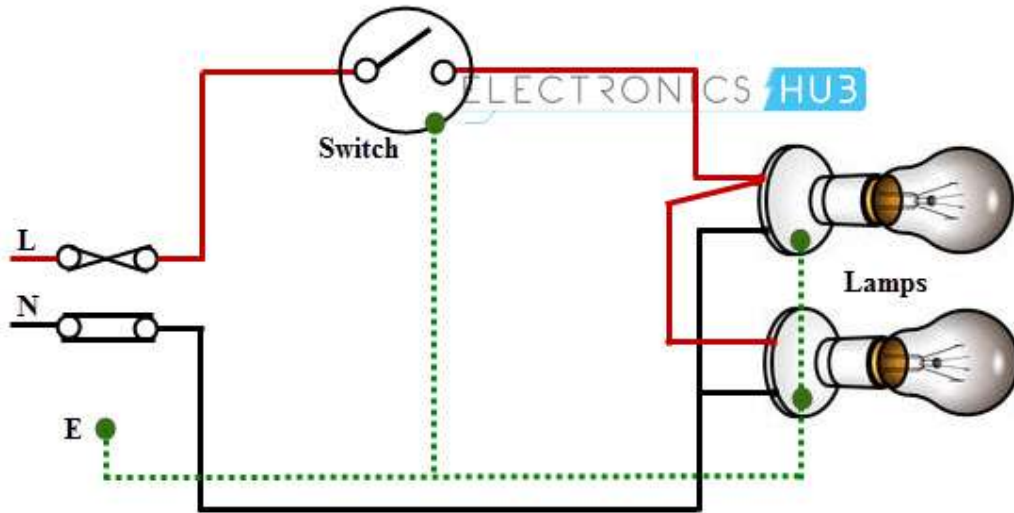

Two Bulbs Controlled by a One Way Switch

In this, two bulbs are connected in parallel with the supply wires (phase and neutrals), which are routed by single one-way switch as shown in figure.

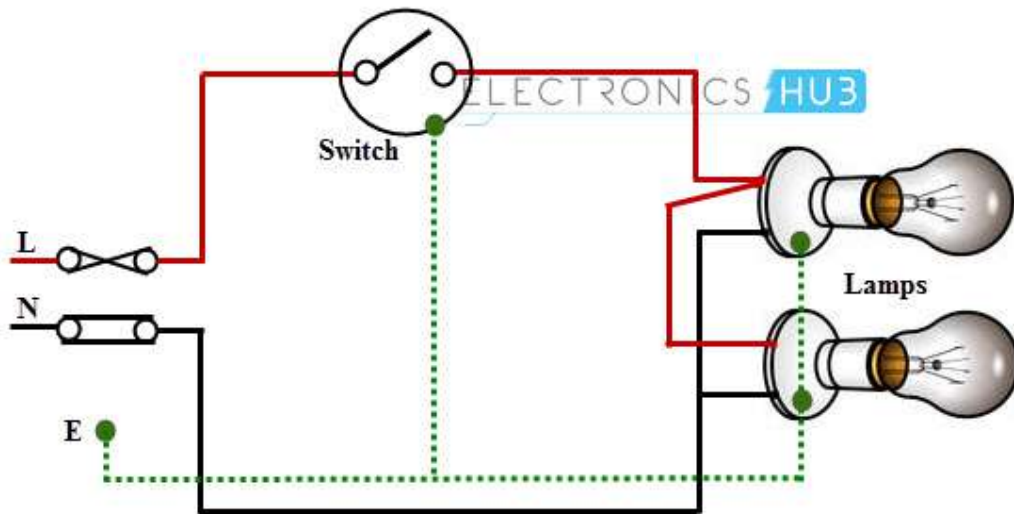

What is a Fuse?

A Fuse or an Electric Fuse is an Electrical / Electronic device that protects the circuit from different electrical faults like over current and overload. Fuses can be considered as a sacrificial element in the circuit as they act as a weak link in the entire circuit.

This is because, a fuse sacrifices itself and reliably opens the circuit when there is an excessive current in the circuit or the circuit is under over load and if there is any short circuit.

Types of Fuses

The fuse is the current interrupting devices which break or open the circuit by fusing the element and thus remove the faulty device from the main supply circuit. The fuses are mainly classified into two types, depends on the input supply voltages they are the AC fuses and the DC fuses. The different types of the fuses are shown in the image below.

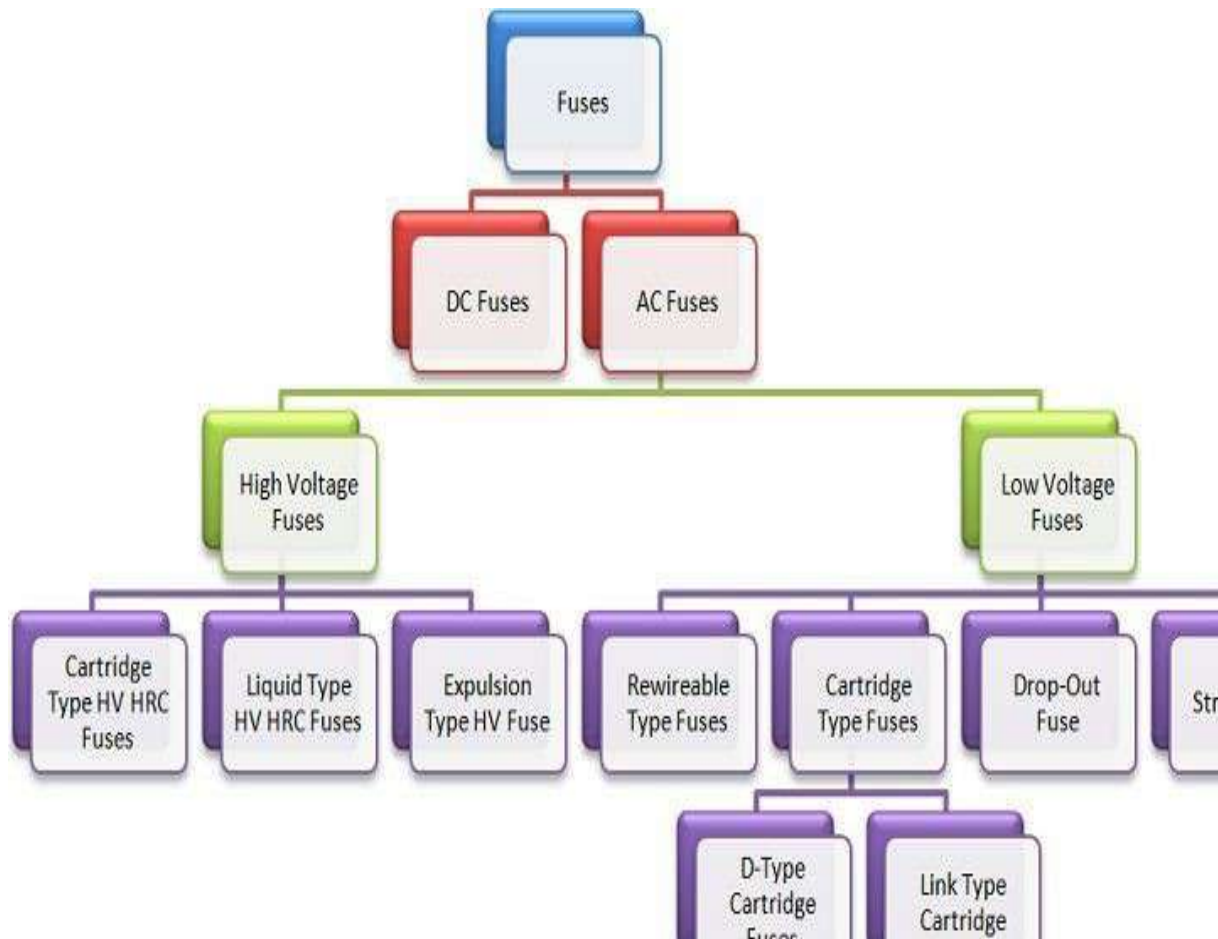

DC Fuse

The DC fuse opens or breaks the circuit when the excessive current flow through it. The only difficulty with the DC fuse is that the arc produced by the direct current is very difficult to extinct because there are no zero current flows in the circuit. For reducing the DC fuse arcing the electrodes are placed more distance apart due to which the size of the fuse increases as compared to AC fuse.

AC Fuses

The AC fuses are categorised into two types they are the low voltage fuses and the high voltage fuses. The frequency of the AC fuses changes it amplitude from 0° to 60° in very one second. Thus, the arc extinction in the AC circuit can be done easily as compared to the [DC circuit](#).

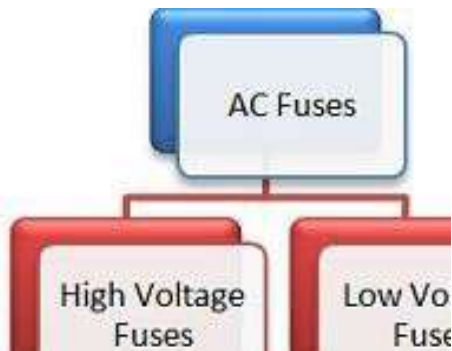

The low voltage fuses can be further divided into four classes shown below in the image Semi-enclosed or rewirable type and totally enclosed, or cartridge type switches are the most commonly used switches.

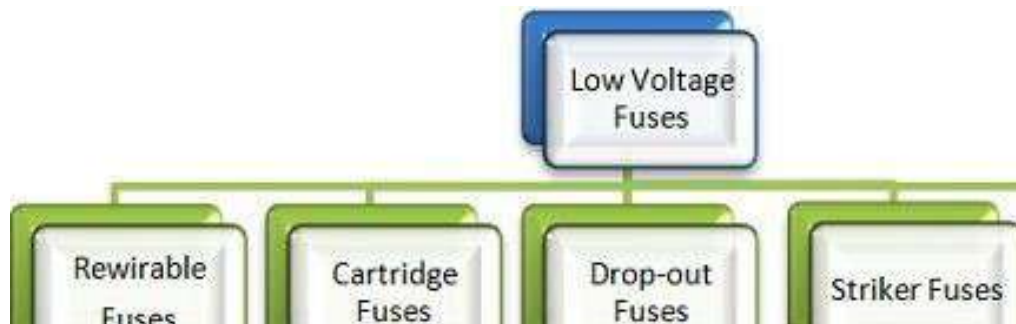

Rewirable Fuses

This type of circuit is mostly used in the small current circuit or for domestic wiring. The fuse case and the fuse carrier are the two main parts of the rewirable fuse. The base of the fuse is made up of porcelain, and it holds the wires which may be made up of lead, tinned copper, aluminium or alloy of tin-lead. The fuse carrier can be easily inserted or taken out in the base without opening the main switch.

Earthing

Earth is used as an electrical conductor for electricity by man over 270 years back. The other name for Electrical Earthing is Grounding. Electrical earthing is done to protect ourselves from shock during fault conditions. The common electrode used for Earthing is copper, which is used for grounding. The basic requirement of every household or industry is to

maintain proper Earthing. The main purpose of the grounding or earthing systems is to provide a reference to the earth. Let us discuss in detail about what is Earthing, why it is required, how Earthing should be done, different types of Earthing and its advantages.

What is Earthing or Grounding?

The safety measures to be taken by connecting any equipment conductive surfaces with Earth Potential is termed as Earthing. Electrical Earthing is shown in the figure.



Earthing

Applications of Electrical Earthing at Low Voltage Systems

- The low voltage system consumption appliances are available at the domestic users where proper electrical earthing is done to protect the electrical appliances and also protect ourselves against electric shocks.
- For domestic users, the common fault that occurs is due to voltage fluctuations. During voltage fluctuations proper electrical earthing plays a key role.
- In high voltage system ($>1\text{kv}$) the focus of the earthing system is less on safety but it is more important to look after the reliability of power supply, protection of equipment. The most common type of fault is the L-G fault in the high voltage system. During the L-G fault, the fault current path is closed through the earth.

Requirement of lighting

- **light** intensity,
- uniformity of **light**,
- dazzle capability and luminance distribution,
- **light** pulsation and colour rendering,
- shading of **light**.

Measurement of light intensity

Illuminance is the metric that is used to measure the light intensity within a space. It is measured in footcandles or lux - it is the amount of light (lumens) falling on a surface (over any given square foot or square meter). Therefore, light intensity is measured in terms of lumens per square foot (footcandles) or lumens per square meter (lux). Measuring the amount of light that falls on a surface allows us to evaluate if we have sufficient light to perform various visual tasks.

Now let's look deeper at how we measure illuminance - We start by looking at the two fundamental lighting units of measure: **lumens and illuminance (footcandles/lux)**. It is common to get these two confused by definition or simply using one inaccurately in place of the other - so let's iron this out.

Ventilation

Ventilation moves outdoor air into a building or a room, and distributes the air within the building or room. The general purpose of ventilation in buildings is to provide healthy air for breathing by both diluting the pollutants originating in the building and removing the pollutants from it ([Etheridge & Sandberg, 1996](#); [Awbi, 2003](#)).

Building ventilation has three basic elements:

- *ventilation rate* — the amount of outdoor air that is provided into the space, and the quality of the outdoor air (see [Annex D](#));
- *airflow direction* — the overall airflow direction in a building, which should be from clean zones to dirty zones; and
- *air distribution or airflow pattern* — the external air should be delivered to each part of the space in an efficient manner and the airborne pollutants generated in each part of the space should also be removed in an efficient manner.

There are three methods that may be used to ventilate a building: natural, mechanical and hybrid (mixed-mode) ventilation.

2.1.1. What is natural ventilation?

Natural forces (e.g. winds and thermal buoyancy force due to indoor and outdoor air density differences) drive outdoor air through purpose-built,

building envelope openings. Purpose-built openings include windows, doors, solar chimneys, wind towers and trickle ventilators. This natural ventilation of buildings depends on climate, building design and human behaviour.

2.1.2. What is mechanical ventilation?

Mechanical fans drive mechanical ventilation. Fans can either be installed directly in windows or walls, or installed in air ducts for supplying air into, or exhausting air from, a room.

The type of mechanical ventilation used depends on climate. For example, in warm and humid climates, infiltration may need to be minimized or prevented to reduce interstitial condensation (which occurs when warm, moist air from inside a building penetrates a wall, roof or floor and meets a cold surface). In these cases, a positive pressure mechanical ventilation system is often used. Conversely, in cold climates, exfiltration needs to be prevented to reduce interstitial condensation, and negative pressure ventilation is used. For a room with locally generated pollutants, such as a bathroom, toilet or kitchen, the negative pressure system is often used.

Problem on ventilation

Being placed on a ventilator can raise your risk for other problems, such as:

- **Atelectasis**, a condition in which your lung or parts of it do not expand fully. This causes the air sacs to collapse, and reduces the amount of oxygen that reaches your blood.
- **Blood clots and skin breakdown.** When using a ventilator, you may need to stay in bed or use a wheelchair. Staying in one position for long periods can raise your risk of blood clots, serious wounds on your skin called bedsores, and infections.

- **Fluid buildup** in the air sacs inside your lungs, which are usually filled with air. This is called pulmonary edema.
- **Lung damage.** Pushing too much air into your lungs or using too much pressure can harm your lungs. Too much oxygen can also damage your lungs. Babies put on a ventilator, especially premature infants, may be at a higher risk of lung damage from excess oxygen therapy and lung infections in childhood and adulthood.
- **Muscle weakness.** Using a ventilator decreases the work your diaphragm and other breathing muscles have to do, so they can become weak. This may lead to some problems and delays in being taken off the machine.
- **Pneumothorax.** This is a condition that develops when air leaks out of your lungs and into the space between the lungs and the chest wall, and sometimes into the muscles and tissues of your chest wall and neck. This leakage can cause pain and shortness of breath. It may cause one or both lungs to collapse. The air that enters the chest could also put pressure on your heart, resulting in a life-threatening situation that would require immediate placement of a tube in your chest to drain the air and decrease the pressure on your heart.
- **Vocal cord damage.** The breathing tube can damage your vocal cords, which could affect the passage of air into the lungs, especially in young children with smaller airways. Tell your doctor if you experience hoarseness or have trouble speaking or breathing after your breathing tube is removed.

Planning and selection of construction equipments

It has been tried to establish that certain factors govern the equipment selection for a particular job. Generally, following four factors are

to be considered when an equipment is to be selected :

- (a) Equipment productivity, (b) Product features and attachments,
- (c) Supplier support, and (d) Cost.

Equipment Productivity

In some types of operations, the production required is a known quantity. The best size of equipment can be chosen to deliver that production at the least cost. Quite often, determining equipment size is not so simple. Past experience is a major factor to assess the size of equipment that will give the best production rate. The buyer's own experience can be supplemented by that of the equipment supplier. Many suppliers can furnish data on equipment capability under varying operating conditions.

Equipment planning can be defined as making or arranging equipment for executing a Project or program before the work being planned is underway. It goes beyond just Deciding what work will be carried out the next day. It involves drawing up a detailed

Study on earth moving equipments like drag line, tractor, bulldozer, Power Shovel

Earthmoving equipment is heavy equipment, typically heavy-duty vehicles designed for construction operations which involve earthworks. They are used to move large amounts of earth, to dig foundations for landscaping and so on. Earthmoving equipment may also be referred to as; heavy trucks, heavy machines, construction equipment, engineering equipment, heavy vehicles and heavy hydraulics. Most earthmoving equipment uses hydraulic drives as the primary source of motion.

There are various types of earthmoving equipments used in construction, few of the pivotal ones are described below.

Excavators

Excavators are heavy construction equipment consisting of a boom, dipper (or stick), bucket and cab on a rotating platform known as the "house". The house sits atop an undercarriage with tracks or wheels. They are a natural progression from the steam shovels and often mistakenly called power shovels. All movement and functions of a [hydraulic excavator](#) are accomplished through the use of hydraulic fluid, with

hydraulic cylinders and hydraulic motors. Due to the linear actuation of hydraulic cylinders, their mode of operation is fundamentally different from [cable-operated excavators](#) which use winches and steel ropes to accomplish the movements.

Backhoe loader

A backhoe loader, also called a loader backhoe, digger in layman's terms, or colloquially shortened to backhoe within the industry, is a heavy equipment vehicle that [consists of a tractor-like unit](#) fitted with a loader-style shovel/bucket on the front and a backhoe on the back. Due to its (relatively) small size and versatility, backhoe loaders are very common in urban engineering and small construction projects (such as building a small house, fixing urban roads, etc.) as well as developing countries. This type of machine is similar to and derived from what is now known as a TLB (Tractor-Loader-Backhoe), which is to say, an agricultural tractor fitted with a front loader and rear backhoe attachment.

Bulldozer

A bulldozer is a tractor equipped with a substantial metal plate (known as a blade) used to push large quantities of soil, sand, rubble, or other such material during construction or conversion work and typically equipped at the rear with a claw-like device (known as a ripper) to loosen densely compacted materials. It is usually a crawler (continuous tracked) tractor. Bulldozers can be found on a wide range of sites, mines and quarries, military bases, heavy industry factories, engineering projects and farms.

Skid-steer loader

A skid loader is a small, rigid-frame, engine-powered machine with lift arms used to attach a wide variety of labor-saving tools or attachments. Skid-steer loaders are typically four-wheel vehicles with the wheels mechanically locked in synchronization on each side, and where the left-side drive wheels can be driven independently of the right-side drive wheels. The wheels typically have no separate steering mechanism and hold a fixed straight alignment on the body of the machine. Turning is accomplished by differential steering, in which the left and right wheel pairs are operated at different speeds, and the machine turns by skidding or dragging its fixed-orientation wheels across the ground. The extremely rigid frame and strong wheel bearings prevent the torsional forces caused by this dragging motion from damaging the machine.

Motor grader

A motor grader, is a construction machine with a long blade used to create a flat surface during the grading process. Although the earliest models were towed behind horses or other powered equipment, most modern graders contain an engine, so are known, technically erroneously, as "motor graders". Typical models have three axles, with the engine and cab situated above the rear axles at one end of the vehicle and a third axle at the front end of the vehicle, with the blade in between. Most motor graders drive the rear axles in tandem, but some also add front wheel drive to improve grading capability. Many graders also have optional attachments for the rear of the machine which can be ripper, scarifier, blade, or compactor.

Trencher

A trencher is a piece of construction equipment used to dig trenches, especially for laying pipes or electrical cables, for installing drainage, or in preparation for trench warfare. Trenchers may range in size from walk-behind models, to attachments for a skid loader or tractor, to very heavy tracked heavy equipment.

Loader

A loader is a heavy equipment machine used in construction to move aside or load materials such as asphalt, demolition debris, dirt, snow, feed, gravel, logs, raw minerals, recycled material, rock, sand, woodchips, etc. into or onto another type of machinery (such as a dump truck, conveyor belt, feed-hopper, or railroad car). There are many types of loader, which, depending on design and application, are called by various names, including bucket loader, front loader, front-end loader, payloader, scoop, shovel, skip loader, wheel loader, or skid-steer.

Wheel tractor-scraper

A wheel tractor-scraper is a piece of heavy equipment used for earthmoving. The rear part of the scraper has a vertically moveable hopper with a sharp horizontal front edge which can be raised or lowered. The front edge cuts into the soil, like a carpenter's plane cutting wood, and fills the hopper. When the hopper is full it is raised, closed, and the scraper can transport its load to the fill area where it is dumped. With a type called an 'elevating scraper' a conveyor belt moves material from the cutting edge into the hopper.

Dragline excavator

A dragline excavator is a piece of heavy equipment used in civil engineering and surface mining. Draglines fall into two broad categories: those that are based on standard, lifting cranes, and the heavy units which have to be built on-site. Most crawler cranes, with an added winch drum on the front, can act as a dragline. These units (like other cranes) are designed to be dismantled and transported over the road on flatbed trailers. Draglines used in civil engineering are almost always of this smaller, crane type. These are used for road, port construction, pond and canal dredging, and as pile driving rigs.

Paver

A paver (paver finisher, asphalt finisher, paving machine) is a piece of construction equipment used to lay asphalt on roads, bridges, parking lots and other such places. It lays the asphalt flat and provides minor compaction before it is compacted by a roller.

- **Study and uses of compacting equipments like tamping rollers, Smooth**

Wheel rollers, Pneumatic tired rollers and vibrating compactors

Compaction is the process of mechanically increasing the density of soil. It is the simple way of increasing the stability and supporting capacity of the soil. Compaction is one kind of densification that is realised by rearrangement of soil particles without a flow of water.

Major reasons for compaction of soil:

- Reduction of air-voids content in Soil
- Increasing load bearing capacities
- Providing Stability
- Reducing water seepage, contraction and swelling
- Prevent frost damages and soil settlement

There are two principal types of compaction force :

01. Static Force:

It is simply the dead weight of the equipment. This is done by applying the downward force on the soil surface and compressing the soil particles. Static force is confined to upper soil layers and limited to the appreciable depth. Kneading and Pressure are two basic mechanisms of static compaction.

02. Vibratory Force:

It is usually an engine drive to create the downward force in addition to the weight of the machine. The vibrating mechanism is usually a rotating eccentric weight of the machine or piston combination. The compactors deliver a rapid sequence of blows to the surfaces, thereby affecting the top layers as well as deeper layers. Vibrations move the material, setting particles in motions and moves them close together for highest density possible.

The different types of compaction equipment used in compaction project depend on the scope of work. The compaction equipment to be used can either be used for some situations or can be a special type which meets the requirements of the particular project.

- Smooth Wheeled Roller
- Sheepsfoot Roller
- Pneumatic Roller
- Vibratory Roller
- Rammer
- Vibratory Plate Compactor

Also Read: [Pneumatic Roller Compaction Equipment](#)

The various types of compaction equipment used in building projects include:

01. Smooth Wheeled Rollers:

It is an important equipment for compaction. It consist large steel drum in front and one or two wheel on rear end.



02. Sheepsfoot Rollers:

Sheepsfoot rollers also known as a tamping roller. Steel drum of sheepsfoot roller consist of many rectangular shaped boots of equal sizes fixed in hexagonal pattern.



03. Pneumatic Roller:

Pneumatic roller is also called rubber tyres roller. Pneumatic roller has number of tyres at the front and at the rear end.



04. Vibratory Roller:

Vibratory roller consist two smooth drums with the vibrator. One is fixed at front and other one on rear side of vibratory roller. Both drums are of the same diameter, length and same weight.



05. Rammers:

Owing and operating cost

Rammer compactor is used for compacting small area and providing impact load to soil. This equipment is light weight and can be hand or machine operated.

Construction equipment owning & operating cost always needs to check before purchase it. Construction Equipment running & maintenance cost needs to be consider just to have the good decision making that does create problem in future to you or your organisation.

Many of the factors are affecting the operating & owning cost. You need to take this with example whatever kind of equipment is taking. Owning Cost & operating cost both are the different things.

Owning Cost

Owning Cost means cost of purchasing the construction equipment whether it's new or used one. In this decision you money need to invest for the long term and wait for the year to get the ROI of Equipment. When you own the equipment then owning cost and operating cost both you need to consider.

Points need to consider:-

Investment ROI.

Cost of operating.

Cost of equipment idleness (when your equipment don't have the work then also there is variable and fixed cost (fixed cost include = interest cost, operator cost)).

Cost of maintenance.

Insurance cost

Residual value

Operating Cost

Operating cost includes the operation related expenses. Ownership cost is not there. When you need to wear the operating cost & when you go for the ownership cost will let you know in below.

Operating cost includes the operator costing, helper costing, fuel costing, maintenance cost other variable expense.

Points need to consider:-

Fuel Costing – Fuel cost is one the major cost in construction equipment because it having the one of the major shares in operating cost so need to consider seriously before owning it or hiring it.

Operator Cost & helper Cost – Operator cost & helper cost is the fixed cost on that you need to spend continually whether your machine working or not.

Maintenance cost – Maintenance Cost is incurred when you run your construction equipment. Maintenance cost includes oil, greasing, filters.

Apart from this cleaning, Oil Analysis, Transportation cost, Inspections, Testing, Sampling, Repairs.

Owning Cost & Operating Cost Formula to check the Decision

Owning costs = purchase price of machine + financing + taxes – disposal price (what you get for that machine when you resell it).

Operating costs = labour + fuel + maintenance + replacement costs of tires, tracks and other components + overhead.

Necessity of soil reinforced

In geotechnical engineering, soil is restored and reinforced with the distribution of minerals and soil nutrients. Soil reinforcement is necessary in lands where chances of erosion are high. It is particularly useful in areas with soft soil as it cannot provide adequate support to any construction or building. This type of soil is also highly susceptible to various environmental and natural factors such as high compressibility, poor shear strength, temperature changes, etc.

In soil reinforcement, different engineering techniques are used to enhance the soil strength. One product that is available is geogrids.

“The MacGridgeogrids are most commonly used in soil reinforcement as they are engineered to be extremely durable and resistant. There are 3 different types of Geogrids available, all of which you can find more about at

Uses of weir mesh

The application of factory cut & bend reinforcement has foreseen adaptability owing to the increased need for speed and better quality. Welded wire mesh has been quite useful in addressing this issue. Welded wire mesh is a great reinforcement component for concrete structures. It is an electric fusion welded prefabricated joined grid consisting of a series of parallel longitudinal wires with accurate spacing welded to cross wires at the required spacing. Welded wire mesh is a steel reinforcement material in concrete. The mesh is used for replacing the traditional “cut & bend” and placing of steel thermo-mechanically treated bars.

Application of welded wire mesh:

Welded wire mesh is also used for other purposes, such as:

- [Building](#) Welded mesh reinforcement is widely used for the reinforcement of concrete structures. In this case, inside poured concrete forms (under the slab, frame foundation slab is poured) laid welded reinforcing mesh, which serves to increase the strength of formed concrete structures.
- Making frames.
- Reinforcement of road surfaces or parking areas so welded reinforcing mesh called road reinforcing mesh grid.
- Manufacture of various fences.
- Used as Masonry mesh.
- Used as a coal mine supporting mesh for coal mine roadway support.

