

LECTURE 1

INTRODUCTION AND REVIEW

Preamble

Engineering science is usually subdivided into number of topics such as

1. Solid Mechanics
2. Fluid Mechanics
3. Heat Transfer
4. Properties of materials and soon Although there are close links between them in terms of the physical principles involved and methods of analysis employed.

The solid mechanics as a subject may be defined as a branch of applied mechanics that deals with behaviours of solid bodies subjected to various types of loadings. This is usually subdivided into further two streams i.e Mechanics of rigid bodies or simply Mechanics and Mechanics of deformable solids.

The mechanics of deformable solids which is branch of applied mechanics is known by several names i.e. strength of materials, mechanics of materials etc.

Mechanics of rigid bodies:

The mechanics of rigid bodies is primarily concerned with the static and dynamic behaviour under external forces of engineering components and systems which are treated as infinitely strong and undeformable. Primarily we deal here with the forces and motions associated with particles and rigid bodies.

Mechanics of deformable solids :

Mechanics of solids:

The mechanics of deformable solids is more concerned with the internal forces and associated changes in the geometry of the components involved. Of particular importance are the properties of the materials used, the strength of which will determine whether the components fail by breaking in service, and the stiffness of which will determine whether the amount of deformation they suffer is acceptable. Therefore, the subject of mechanics of materials or strength of materials is central to the whole activity of engineering design. Usually the objectives in analysis here will be the determination of the stresses, strains, and deflections produced by loads. Theoretical analyses and experimental results have an equal roles in this field.

Analysis of stress and strain :

Concept of stress : Let us introduce the concept of stress as we know that the main problem of engineering mechanics of material is the investigation of the internal resistance of the body, i.e. the nature of forces set up within a body to balance the effect of the externally applied forces.

The externally applied forces are termed as loads. These externally applied forces may be due to any one of the reason.

- (i) due to service conditions
- (ii) due to environment in which the component works
- (iii) through contact with other members
- (iv) due to fluid pressures
- (v) due to gravity or inertia forces.

As we know that in mechanics of deformable solids, externally applied forces acts on a body and body suffers a deformation. From equilibrium point of view, this action should be opposed or reacted by internal forces which are set up within the particles of material due to cohesion.

These internal forces give rise to a concept of stress. Therefore, let us define a stress
Therefore, let us define a term stress

Stress:

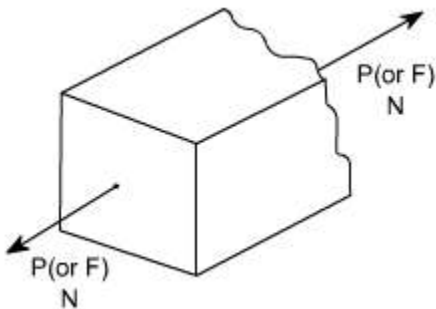

Let us consider a rectangular bar of some cross – sectional area and subjected to some load or force (in Newtons)

Let us imagine that the same rectangular bar is assumed to be cut into two halves at section XX. The each portion of this rectangular bar is in equilibrium under the action of load P and the internal forces acting at the section XX has been shown

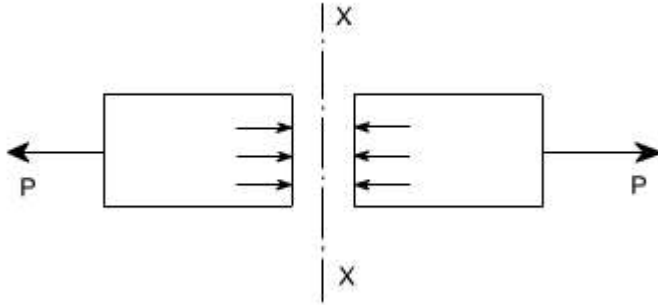

Now stress is defined as the force intensity or force per unit area. Here we use a symbol σ to represent the stress.

$$\sigma = \frac{P}{A}$$

Where A is the area of the $X - X$ section

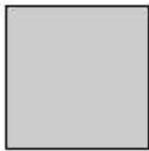

Here we are using an assumption that the total force or total load carried by the rectangular bar is uniformly distributed over its cross – section.

But the stress distributions may be far from uniform, with local regions of high stress known as stress concentrations.

If the force carried by a component is not uniformly distributed over its cross – sectional area, A , we must consider a small area, ' dA ' which carries a small load dP , of the total force ' P ', Then definition of stress is

$$\sigma = \frac{\delta F}{\delta A}$$

As a particular stress generally holds true only at a point, therefore it is defined mathematically as

$$\sigma = \lim_{\delta A \rightarrow 0} \frac{\delta F}{\delta A}$$

Units :

The basic units of stress in S.I units i.e. (International system) are N / m^2 (or Pa)

$$\text{MPa} = 10^6 \text{ Pa}$$

$$\text{GPa} = 10^9 \text{ Pa}$$

$$\text{KPa} = 10^3 \text{ Pa}$$

Some times N / mm^2 units are also used, because this is an equivalent to MPa. While US customary unit is pound per square inch psi.

TYPES OF STRESSES :

only two basic stresses exists : (1) normal stress and (2) shear stress. Other stresses either are similar to these basic stresses or are a combination of these e.g. bending stress is a combination tensile, compressive and shear stresses. Torsional stress, as encountered in twisting of a shaft is a shearing stress.

Let us define the normal stresses and shear stresses in the following sections.

Normal stresses : We have defined stress as force per unit area. If the stresses are normal to the areas concerned, then these are termed as normal stresses. The normal stresses are generally denoted by a Greek letter (σ)

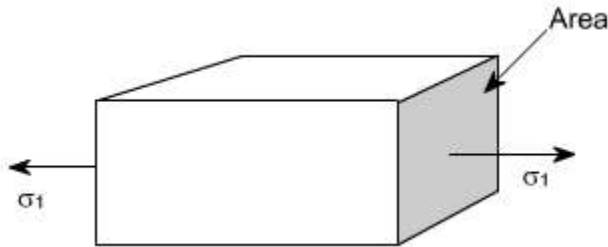

This is also known as uniaxial state of stress, because the stresses acts only in one direction however, such a state rarely exists, therefore we have biaxial and triaxial state of stresses where either the two mutually perpendicular normal stresses acts or three mutually perpendicular normal stresses acts as shown in the figures below :

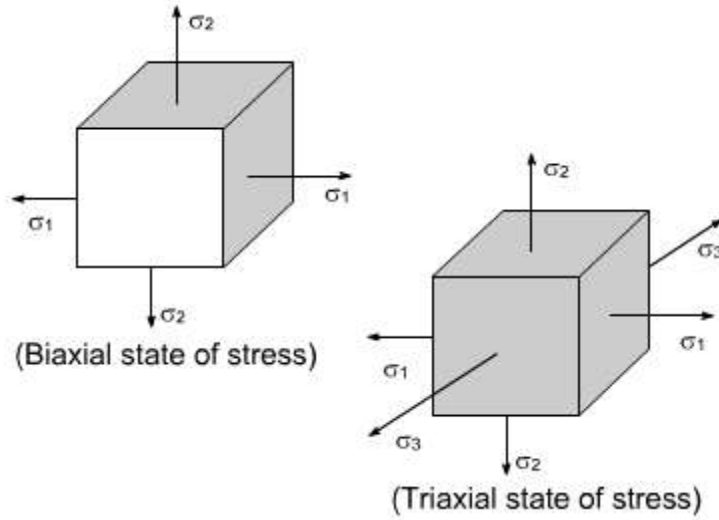

Tensile or compressive stresses :

The normal stresses can be either tensile or compressive whether the stresses acts out of the area or into the area

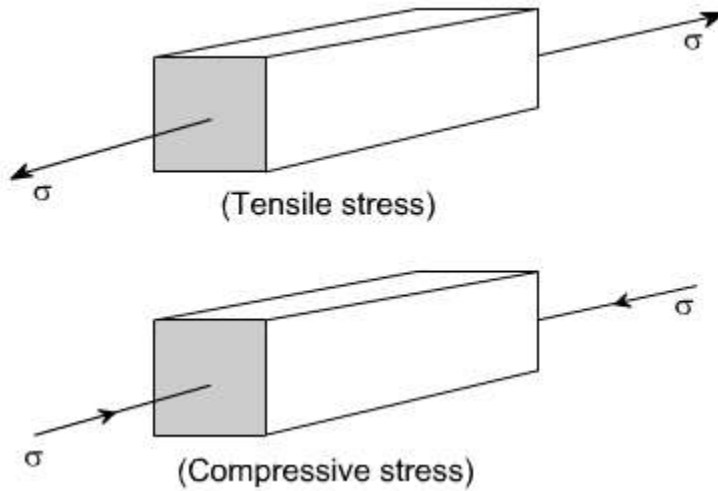

Bearing Stress : When one object presses against another, it is referred to a bearing stress (They are in fact the compressive stresses).

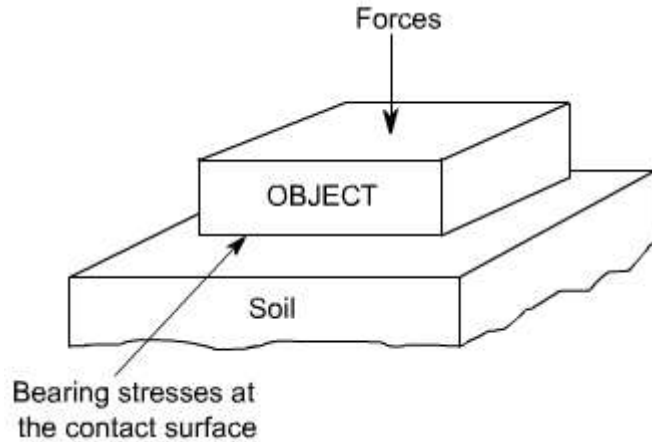

Shear stresses :

Let us consider now the situation, where the cross – sectional area of a block of material is subject to a distribution of forces which are parallel, rather than normal, to the area concerned. Such forces are associated with a shearing of the material, and are referred to as shear forces. The resulting force intensities are known as shear stresses.

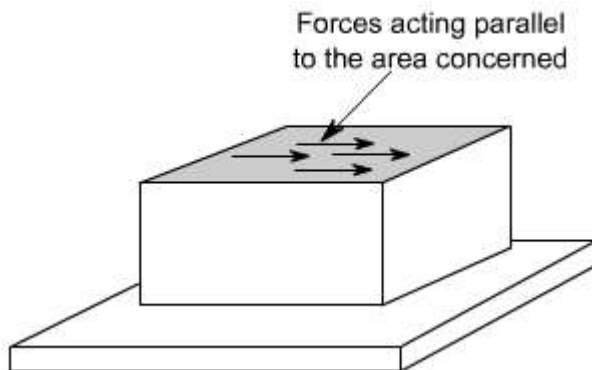

The resulting force intensities are known as shear stresses, the mean shear stress being equal to

$$\tau = \frac{P}{A}$$

Where P is the total force and A the area over which it acts.

As we know that the particular stress generally holds good only at a point therefore we can define shear stress at a point as

$$\tau = \lim_{\delta A \rightarrow 0} \frac{\delta F}{\delta A}$$

The greek symbol τ (tau) (suggesting tangential) is used to denote shear stress.

However, it must be borne in mind that the stress (resultant stress) at any point in a body is basically resolved into two components s and t one acts perpendicular and other parallel to the area concerned, as it is clearly defined in the following figure.

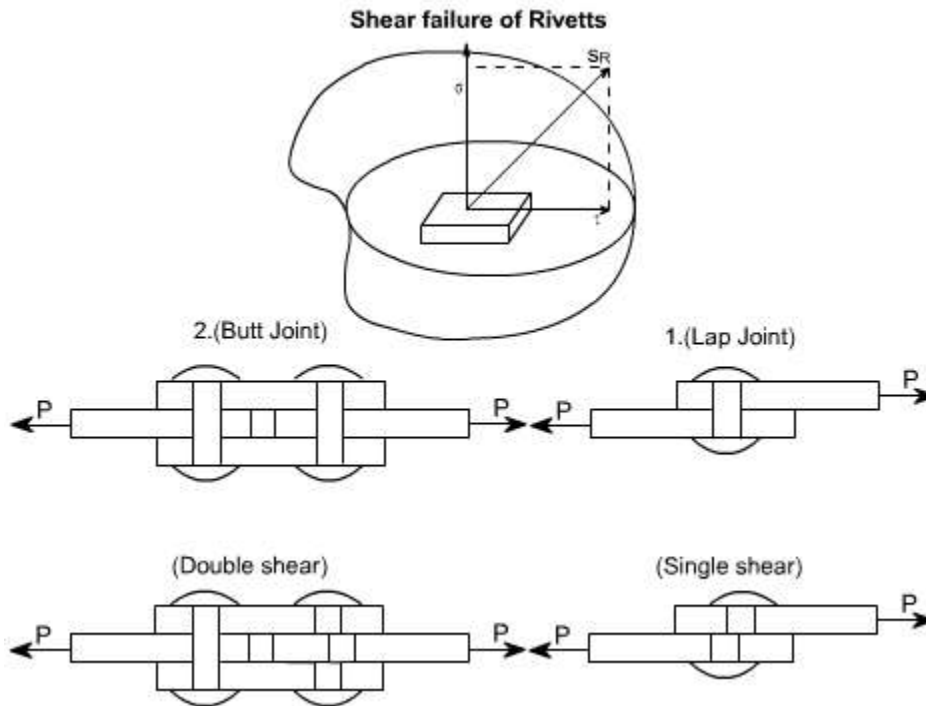

The single shear takes place on the single plane and the shear area is the cross - sectional of the rivett, whereas the double shear takes place in the case of Butt joints of rivetts and the shear area is the twice of the X - sectional area of the rivett.

LECTURE 2

ANALYSIS OF STERSSES

General State of stress at a point :

Stress at a point in a material body has been defined as a force per unit area. But this definition is some what ambiguous since it depends upon what area we consider at that point. Let us, consider a point 'q' in the interior of the body

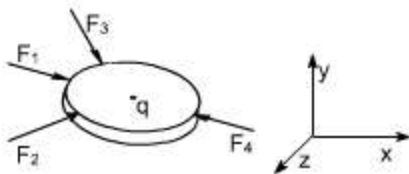

Let us pass a cutting plane through a pont 'q' perpendicular to the x - axis as shown below

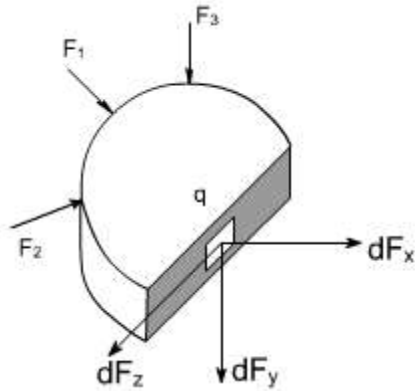

The corresponding force components can be shown like this

$$dF_x = s_{xx} \cdot da_x$$

$$dF_y = t_{xy} \cdot da_x$$

$$dF_z = t_{xz} \cdot da_x$$

where da_x is the area surrounding the point 'q' when the cutting plane \hat{n} is to x - axis.

In a similar way it can be assumed that the cutting plane is passed through the point 'q' perpendicular to the y - axis. The corresponding force components are shown below

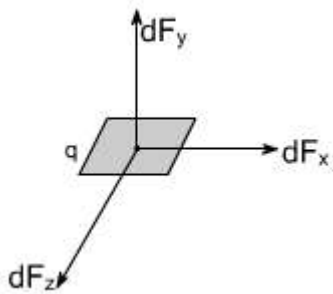

The corresponding force components may be written as

$$dF_x = t_{yx} \cdot da_y$$

$$dF_y = s_{yy} \cdot da_y$$

$$dF_z = t_{yz} \cdot da_y$$

where da_y is the area surrounding the point 'q' when the cutting plane \hat{n} is to y - axis.

In the last it can be considered that the cutting plane is passed through the point 'q' perpendicular to the z - axis.

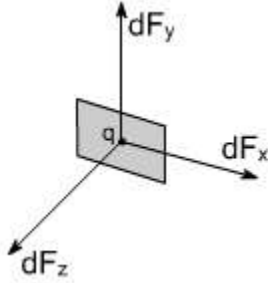

The corresponding force components may be written as

$$dF_x = t_{zx} \cdot da_z$$

$$dF_y = t_{zy} \cdot da_z$$

$$dF_z = s_{zz} \cdot da_z$$

where da_z is the area surrounding the point 'q' when the cutting plane \perp is to z - axis.

Thus, from the foregoing discussion it is amply clear that there is nothing like stress at a point 'q' rather we have a situation where it is a combination of state of stress at a point q. Thus, it becomes imperative to understand the term state of stress at a point 'q'. Therefore, it becomes easy to express a state of stress by the scheme as discussed earlier, where the stresses on the three mutually perpendicular planes are labelled in the manner as shown earlier. The state of stress as depicted earlier is called the general or a triaxial state of stress that can exist at any interior point of a loaded body.

Before defining the general state of stress at a point. Let us make ourselves conversant with the notations for the stresses.

We have already chosen to distinguish between normal and shear stress with the help of symbols s and t .

Cartesian - co-ordinate system

In the Cartesian co-ordinates system, we make use of the axes, X, Y and Z

Let us consider the small element of the material and show the various normal stresses acting the faces

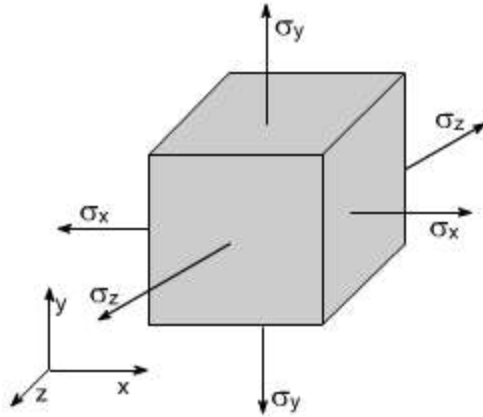

Thus, in the Cartesian co-ordinates system the normal stresses have been represented by s_x , s_y and s_z .

Cylindrical - co-ordinate system

In the Cylindrical - co-ordinate system we make use of co-ordinates r , θ and Z .

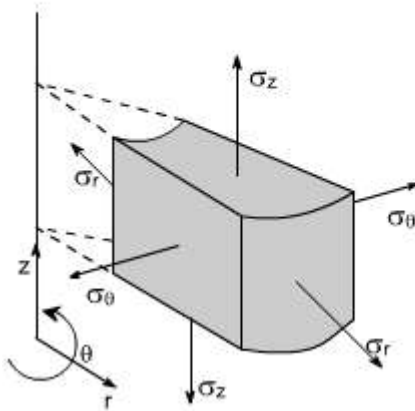

Thus, in the Cylindrical co-ordinates system, the normal stresses i.e components acting over a element is being denoted by s_r , s_θ and s_z .

Sign convention : The tensile forces are termed as (+ve) while the compressive forces are termed as negative (-ve).

First sub – script : it indicates the direction of the normal to the surface.

Second subscript : it indicates the direction of the stress.

It may be noted that in the case of normal stresses the double script notation may be dispensed with as the direction of the normal stress and the direction of normal to the

surface of the element on which it acts is the same. Therefore, a single subscript notation as used is sufficient to define the normal stresses.

Shear Stresses : With shear stress components, the single subscript notation is not practical, because such stresses are in direction parallel to the surfaces on which they act. We therefore have two directions to specify, that of normal to the surface and the stress itself. To do this, we stress itself. To do this, we attach two subscripts to the symbol ' t ' , for shear stresses.

In cartesian and polar co-ordinates, we have the stress components as shown in the figures.

$t_{xy} , t_{yx} , t_{yz} , t_{zy} , t_{zx} , t_{xz}$

$t_{r\theta} , t_{\theta r} , t_{\theta z} , t_{z\theta} , t_{rz} , t_{zr}$

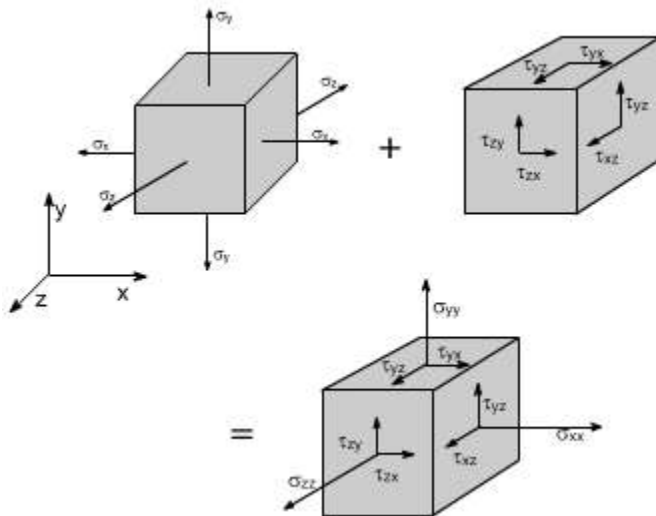

So as shown above, the normal stresses and shear stress components indicated on a small element of material separately has been combined and depicted on a single element. Similarly for a cylindrical co-ordinate system let us shown the normal and shear stresses components separately.

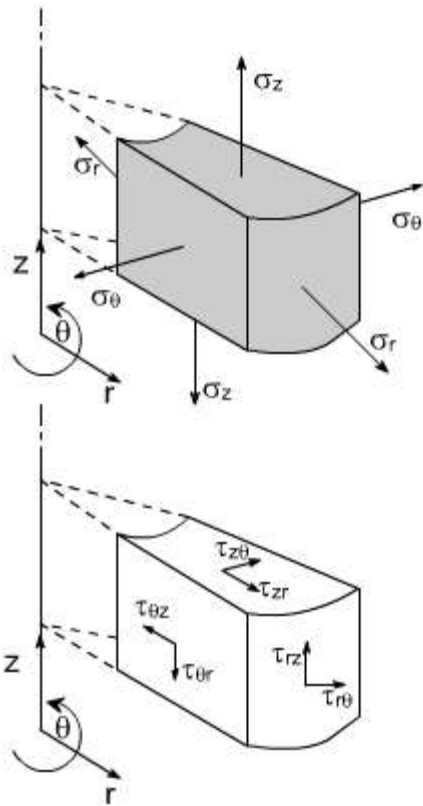

Now let us combine the normal and shear stress components as shown below :

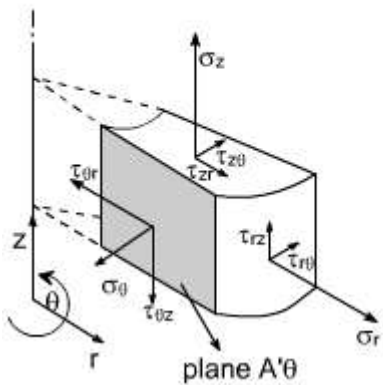

Now let us define the state of stress at a point formally.

State of stress at a point :

By state of stress at a point, we mean an information which is required at that point such that it remains under equilibrium. or simply a general state of stress at a point involves all the normal stress components, together with all the shear stress components as shown in earlier figures.

Therefore, we need nine components, to define the state of stress at a point

$$s_x \quad t_{xy} \quad t_{xz}$$

$$s_y \quad t_{yx} \quad t_{yz}$$

$$s_z \quad t_{zx} \quad t_{zy}$$

If we apply the conditions of equilibrium which are as follows:

$$\sum F_x = 0 ; \sum M_x = 0$$

$$\sum F_y = 0 ; \sum M_y = 0$$

$$\sum F_z = 0 ; \sum M_z = 0$$

Then we get

$$t_{xy} = t_{yx}$$

$$t_{yz} = t_{zy}$$

$$t_{zx} = t_{xz}$$

Then we will need only six components to specify the state of stress at a point i.e

$$s_x , s_y , s_z , t_{xy} , t_{yz} , t_{zx}$$

Now let us define the concept of complementary shear stresses.

Complementary shear stresses:

The existence of shear stresses on any two sides of the element induces complementary shear stresses on the other two sides of the element to maintain equilibrium.

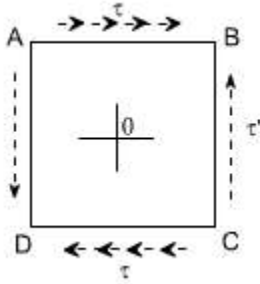

on planes AB and CD, the shear stress t acts. To maintain the static equilibrium of this element, on planes AD and BC, t' should act, we shall see that t' which is known as the complementary shear stress would come out to equal and opposite to the t . Let us prove this thing for a general case as discussed below:

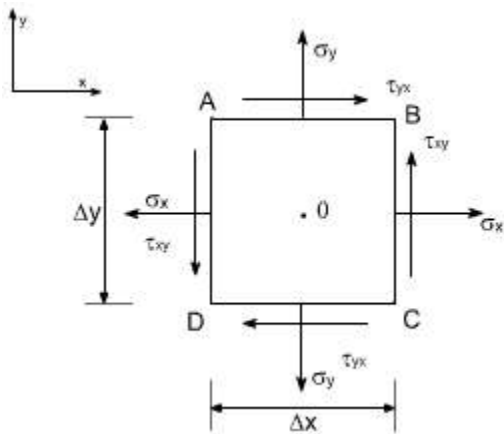

The figure shows a small rectangular element with sides of length Δx , Δy parallel to x and y directions. Its thickness normal to the plane of paper is Δz in z – direction. All nine normal and shear stress components may act on the element, only those in x and y directions are shown.

Sign conventions for shear stresses:

Direct stresses or normal stresses

- tensile +ve
- compressive –ve

Shear stresses:

- tending to turn the element C.W +ve.
- tending to turn the element C.C.W – ve.

The resulting forces applied to the element are in equilibrium in x and y direction. (Although other normal and shear stress components are not shown, their presence does not affect the final conclusion).

Assumption : The weight of the element is neglected.

Since the element is a static piece of solid body, the moments applied to it must also be in equilibrium. Let 'O' be the centre of the element. Let us consider the axis through the point 'O'. the resultant force associated with normal stresses s_x and s_y acting on the sides of the element each pass through this axis, and therefore, have no moment.

Now forces on top and bottom surfaces produce a couple which must be balanced by the forces on left and right hand faces

Thus,

$$t_{yx} \cdot D x \cdot D z \cdot D y = t_{xy} \cdot D x \cdot D z \cdot D y$$

$$\tau_{yx} = \tau_{xy}$$

In other word, the complementary shear stresses are equal in magnitude. The same form of relationship can be obtained for the other two pair of shear stress components to arrive at the relations

$$\begin{aligned} \tau_{zy} &= \tau_{yz} \\ \tau_{zx} &= \tau_{xz} \end{aligned}$$

LECTURE 3

Analysis of Stresses:

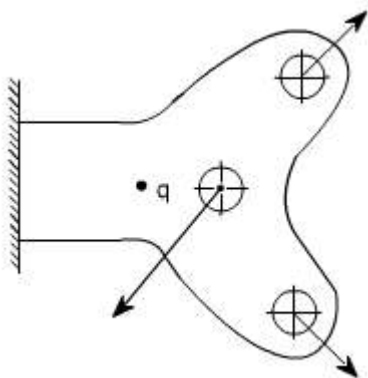

Consider a point 'q' in some sort of structural member like as shown in figure below. Assuming that at point exist. 'q' a plane state of stress exist. i.e. the state of state stress is to describe by a parameters s_x , s_y and t_{xy} These stresses could be indicate a on the two

dimensional diagram as shown below:

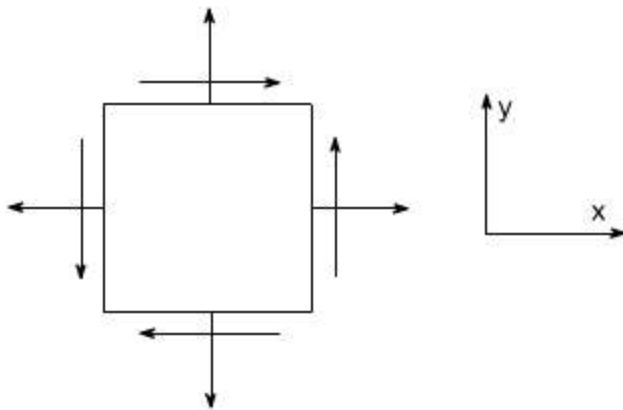

This is a common way of representing the stresses. It must be realized that the material is unaware of what we have called the x and y axes. i.e. the material has to resist the loads irrespective of how we wish to name them or whether they are horizontal, vertical or otherwise. Furthermore, the material will fail when the stresses exceed beyond a permissible value. Thus, a fundamental problem in engineering design is to determine the maximum normal stress or maximum shear stress at any particular point in a body. There is no reason to believe a priori that s_x , s_y and t_{xy} are the maximum values. Rather the maximum stresses may associate themselves with some other planes located at 'q'. Thus, it becomes imperative to determine the values of s_q and t_q . In order to achieve this let us consider the following.

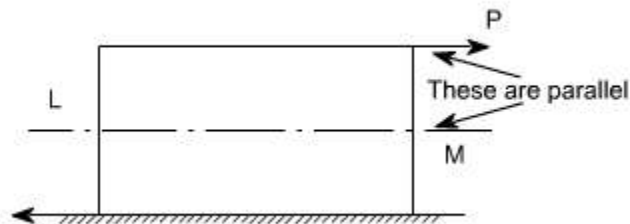

Shear stress:

If the applied load P consists of two equal and opposite parallel forces not in the same line, then there is a tendency for one part of the body to slide over or shear from the other part across any section LM. If the cross section at LM measured parallel to the load is A, then the average value of shear stress $t = P/A$. The shear stress is tangential to the area over which it acts.

If the shear stress varies then at a point then t may be defined as
$$\tau = \lim_{\delta A \rightarrow 0} \frac{\delta P}{\delta A}$$

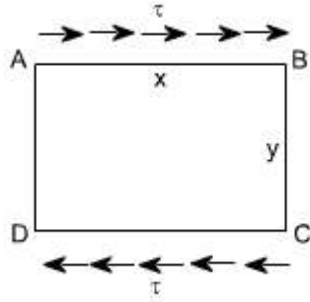

Complementary shear stress:

Let ABCD be a small rectangular element of sides x , y and z perpendicular to the plane of paper let there be shear stress acting on planes AB and CD

It is obvious that these stresses will form a couple $(\tau \cdot xz)y$ which can only be balanced by tangential forces on planes AD and BC. These are known as complementary shear stresses. i.e. the existence of shear stresses on sides AB and CD of the element implies that there must also be complementary shear stresses on to maintain equilibrium.

Let τ' be the complementary shear stress induced on planes

AD and BC. Then for the equilibrium $(\tau \cdot xz)y = \tau' (yz)x$

$$\tau = \tau'$$

Thus, every shear stress is accompanied by an equal complementary shear stress.

Stresses on oblique plane: Till now we have dealt with either pure normal direct stress or pure shear stress. In many instances, however both direct and shear stresses act and the resultant stress across any section will be neither normal nor tangential to the plane.

A plane state of stress is a 2 dimensional state of stress in a sense that the stress components in one direction are all zero i.e

$$\sigma_z = \tau_{yz} = \tau_{zx} = 0$$

examples of plane state of stress includes plates and shells.

Consider the general case of a bar under direct load F giving rise to a stress σ_y vertically

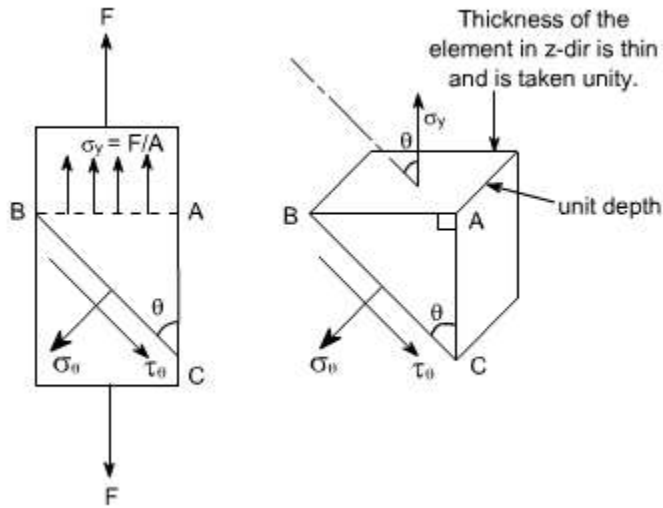

The stress acting at a point is represented by the stresses acting on the faces of the element enclosing the point.

The stresses change with the inclination of the planes passing through that point i.e. the stress on the faces of the element vary as the angular position of the element changes.

Let the block be of unit depth now considering the equilibrium of forces on the triangle portion ABC

Resolving forces perpendicular to BC, gives

$$s_q \cdot BC \cdot 1 = s_y \sin \theta \cdot AB \cdot 1$$

$$\text{but } AB/BC = \sin \theta \text{ or } AB = BC \sin \theta$$

Substituting this value in the above equation, we get

$$s_q \cdot BC \cdot 1 = s_y \sin \theta \cdot BC \sin \theta \cdot 1 \text{ or } \boxed{\sigma_\theta = s_y \cdot \sin^2 2\theta} \quad (1)$$

Now resolving the forces parallel to BC

$$t_q \cdot BC \cdot 1 = s_y \cos \theta \cdot AB \sin \theta \cdot 1$$

$$\text{again } AB = BC \cos \theta$$

$$t_q \cdot BC \cdot 1 = s_y \cos \theta \cdot BC \sin \theta \cdot 1 \text{ or } t_q = s_y \sin \theta \cos \theta$$

$$\boxed{\tau_\theta = \frac{1}{2} \cdot s_y \cdot \sin 2\theta} \quad (2)$$

If $q = 90^\circ$ the BC will be parallel to AB and $t_q = 0$, i.e. there will be only direct stress or normal stress.

By examining the equations (1) and (2), the following conclusions may be drawn

- (i) The value of direct stress s_q is maximum and is equal to s_y when $q = 90^\circ$.
- (ii) The shear stress t_q has a maximum value of $0.5 s_y$ when $q = 45^\circ$
- (iii) The stresses s_q and t_q are not simply the resolution of s_y

Material subjected to pure shear:

Consider the element shown to which shear stresses have been applied to the sides AB and DC

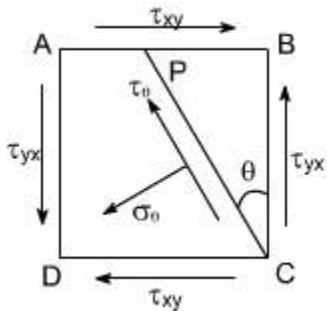

Complementary shear stresses of equal value but of opposite effect are then set up on the sides AD and BC in order to prevent the rotation of the element. Since the applied and complementary shear stresses are of equal value on the x and y planes. Therefore, they are both represented by the symbol t_{xy} .

Now consider the equilibrium of portion of PBC

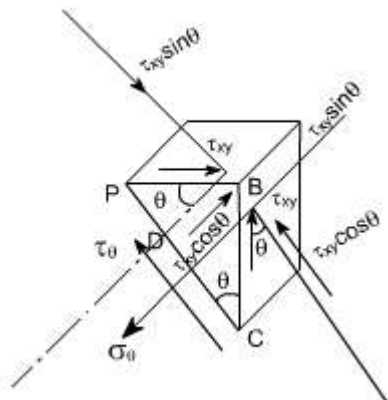

Assuming unit depth and resolving normal to PC or in the direction of s_q

$$s_q \cdot PC \cdot 1 = t_{xy} \cdot PB \cdot \cos q \cdot 1 + t_{xy} \cdot BC \cdot \sin q \cdot 1$$

$$= t_{xy} \cdot PB \cdot \cos q + t_{xy} \cdot BC \cdot \sin q$$

Now writing PB and BC in terms of PC so that it cancels out from the two sides

$$PB/PC = \sin q \quad BC/PC = \cos q$$

$$s_q \cdot PC \cdot 1 = t_{xy} \cdot \cos q \sin q PC + t_{xy} \cdot \cos q \cdot \sin q PC$$

$$s_q = 2 t_{xy} \sin q \cos q$$

$$s_q = t_{xy} \cdot 2 \cdot \sin q \cos q$$

$$\boxed{\sigma_{\theta} = \tau_{xy} \cdot \sin 2\theta} \quad (1)$$

Now resolving forces parallel to PC or in the direction t_q . then $t_{xy} PC \cdot 1 = t_{xy} \cdot PB \sin q - t_{xy} \cdot BC \cos q$

-ve sign has been put because this component is in the same direction as that of t_q .

again converting the various quantities in terms of PC we have

$$t_{xy} PC \cdot 1 = t_{xy} \cdot PB \cdot \sin^2 q - t_{xy} \cdot PC \cos^2 q$$

$$= -[t_{xy} (\cos^2 q - \sin^2 q)]$$

$$= -t_{xy} \cos 2q \quad \text{or} \quad \boxed{\tau_{\theta} = -\tau_{xy} \cos 2\theta} \quad (2)$$

the negative sign means that the sense of t_q is opposite to that of assumed one. Let us examine the equations (1) and (2) respectively

From equation (1) i.e,

$$s_q = t_{xy} \sin 2q$$

The equation (1) represents that the maximum value of s_q is t_{xy} when $q = 45^\circ$.

Let us take into consideration the equation (2) which states that

$$t_q = -t_{xy} \cos 2q$$

It indicates that the maximum value of t_q is t_{xy} when $q = 0^\circ$ or 90° . it has a value zero

when $\theta = 45^\circ$.

From equation (1) it may be noticed that the normal component s_q has maximum and minimum values of $+t_{xy}$ (tension) and $-t_{xy}$ (compression) on plane at $\pm 45^\circ$ to the applied shear and on these planes the tangential component t_q is zero.

Hence the system of pure shear stresses produces an equivalent direct stress system, one set compressive and one tensile each located at 45° to the original shear directions as depicted in the figure below:

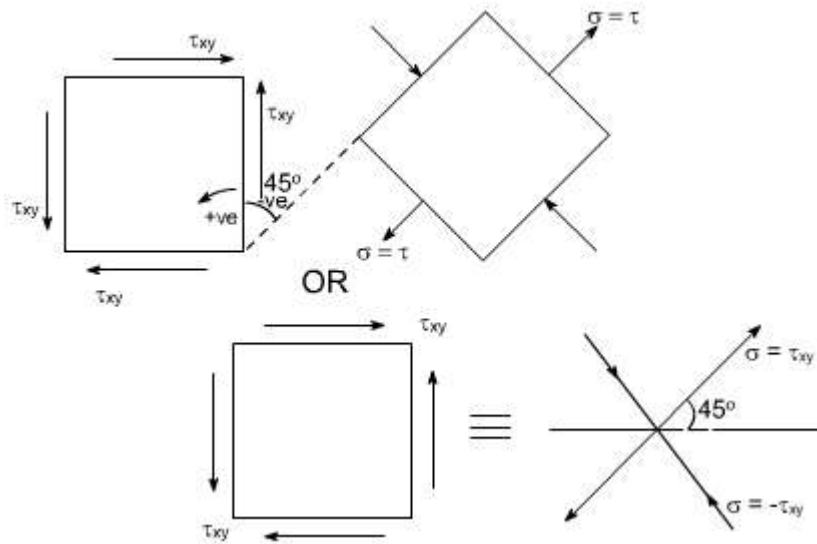

Material subjected to two mutually perpendicular direct stresses:

Now consider a rectangular element of unit depth, subjected to a system of two direct stresses both tensile, s_x and s_y acting right angles to each other.

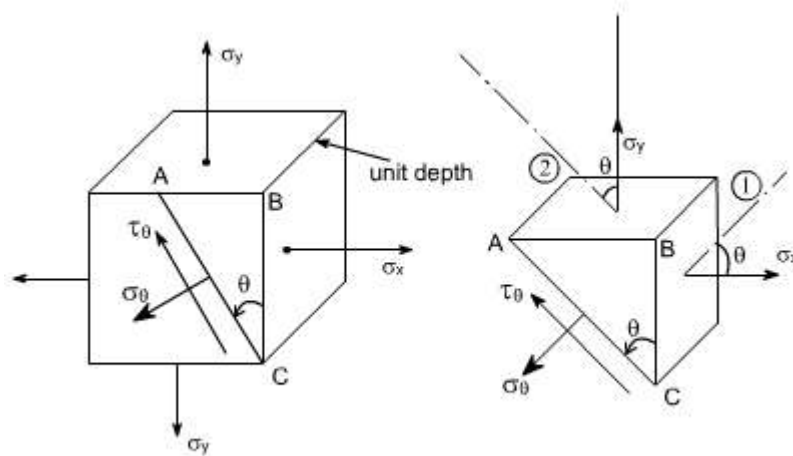

for equilibrium of the portion ABC, resolving perpendicular to AC

$$s_q \cdot AC \cdot 1 = s_y \sin q \cdot AB \cdot 1 + s_x \cos q \cdot BC \cdot 1$$

converting AB and BC in terms of AC so that AC cancels out from the sides

$$s_q = s_y \sin^2 q + s_x \cos^2 q$$

Further, recalling that $\cos^2 q - \sin^2 q = \cos 2q$ or $(1 - \cos 2q)/2 = \sin^2 q$

Similarly $(1 + \cos 2q)/2 = \cos^2 q$

Hence by these transformations the expression for s_q reduces to

$$= 1/2 s_y (1 - \cos 2q) + 1/2 s_x (1 + \cos 2q)$$

On rearranging the various terms we get

$$\boxed{\sigma_\theta = \left(\frac{\sigma_x + \sigma_y}{2} \right) + \left(\frac{\sigma_x - \sigma_y}{2} \right) \cos 2\theta} \quad (3)$$

Now resolving parallel to AC

$$s_q \cdot AC \cdot 1 = -t_{xy} \cdot \cos q \cdot AB \cdot 1 + t_{xy} \cdot BC \cdot \sin q \cdot 1$$

The -ve sign appears because this component is in the same direction as that of AC.

Again converting the various quantities in terms of AC so that the AC cancels out from the two sides.

$$\tau_\theta \cdot AC \cdot 1 = [\tau_x \cos \theta \sin \theta - \sigma_y \sin \theta \cos \theta] AC$$

$$\tau_\theta = (\sigma_x - \sigma_y) \sin \theta \cos \theta$$

$$= \frac{(\sigma_x - \sigma_y)}{2} \sin 2\theta$$

$$\text{or } \boxed{\tau_\theta = \frac{(\sigma_x - \sigma_y)}{2} \sin 2\theta} \quad (4)$$

Conclusions :

The following conclusions may be drawn from equation (3) and (4)

- (i) The maximum direct stress would be equal to s_x or s_y which ever is the greater, when $q = 0^\circ$ or 90°

(ii) The maximum shear stress in the plane of the applied stresses occurs when $q = 45^\circ$

$$\tau_{\max} = \frac{(\sigma_x - \sigma_y)}{2}$$

LECTURE 4

Material subjected to combined direct and shear stresses:

Now consider a complex stress system shown below, acting on an element of material.

The stresses σ_x and σ_y may be compressive or tensile and may be the result of direct forces or as a result of bending. The shear stresses may be as shown or completely reversed and occur as a result of either shear force or torsion as shown in the figure below:

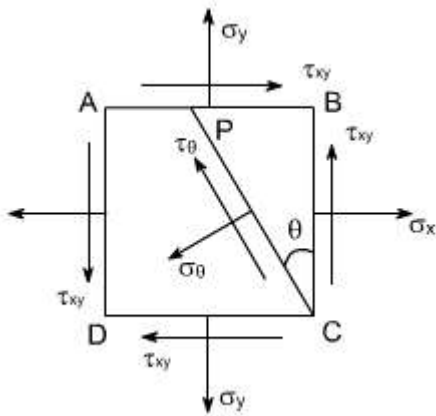

As per the double subscript notation the shear stress on the face BC should be notified as τ_{yx} , however, we have already seen that for a pair of shear stresses there is a set of complementary shear stresses generated such that $\tau_{yx} = \tau_{xy}$

By looking at this state of stress, it may be observed that this state of stress is combination of two different cases:

(i) Material subjected to pure state of stress shear. In this case the various formulas derived are as follows

$$s_q = \tau_{yx} \sin 2q$$

$$t_q = -\tau_{yx} \cos 2q$$

(ii) Material subjected to two mutually perpendicular direct stresses. In this case the various formula's derived are as follows.

$$\sigma_{\theta} = \frac{(\sigma_x + \sigma_y)}{2} + \frac{(\sigma_x - \sigma_y)}{2} \cos 2\theta$$

$$\tau_{\theta} = \frac{(\sigma_x - \sigma_y)}{2} \sin 2\theta$$

To get the required equations for the case under consideration, let us add the respective equations for the above two cases such that

$$\sigma_{\theta} = \frac{(\sigma_x + \sigma_y)}{2} + \frac{(\sigma_x - \sigma_y)}{2} \cos 2\theta + \tau_{xy} \sin 2\theta$$

$$\tau_{\theta} = \frac{(\sigma_x - \sigma_y)}{2} \sin 2\theta - \tau_{xy} \cos 2\theta$$

These are the equilibrium equations for stresses at a point. They do not depend on material proportions and are equally valid for elastic and inelastic behaviour

This eqn gives two values of 2θ that differ by 180° . Hence the planes on which maximum and minimum normal stresses occur 90° apart.

For σ_{θ} to be a maximum or minimum $\frac{d\sigma_{\theta}}{d\theta} = 0$

Now

$$\sigma_{\theta} = \frac{(\sigma_x + \sigma_y)}{2} + \frac{(\sigma_x - \sigma_y)}{2} \cos 2\theta + \tau_{xy} \sin 2\theta$$

$$\frac{d\sigma_{\theta}}{d\theta} = -\frac{1}{2}(\sigma_x - \sigma_y) \sin 2\theta \cdot 2 + \tau_{xy} \cos 2\theta \cdot 2$$

$$= 0$$

$$\text{i.e. } -(\sigma_x - \sigma_y) \sin 2\theta + \tau_{xy} \cos 2\theta = 0$$

$$\tau_{xy} \cos 2\theta = (\sigma_x - \sigma_y) \sin 2\theta$$

Thus,
$$\boxed{\tan 2\theta = \frac{2\tau_{xy}}{(\sigma_x - \sigma_y)}}$$

From the triangle it may be determined

$$\cos 2\theta = \frac{(\sigma_x - \sigma_y)}{\sqrt{(\sigma_x - \sigma_y)^2 + 4\tau_{xy}^2}}$$

$$\sin 2\theta = \frac{2\tau_{xy}}{\sqrt{(\sigma_x - \sigma_y)^2 + 4\tau_{xy}^2}}$$

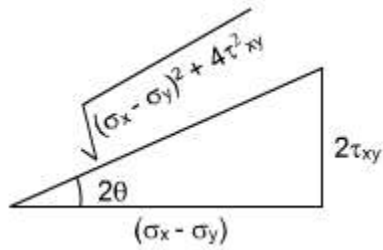

Substituting the values of $\cos 2\theta$ and $\sin 2\theta$ in equation (5) we get

$$\begin{aligned}\sigma_{\theta} &= \frac{(\sigma_x + \sigma_y)}{2} + \frac{(\sigma_x - \sigma_y)}{2} \cos 2\theta + \tau_{xy} \sin 2\theta \\ \sigma_{\theta} &= \frac{(\sigma_x + \sigma_y)}{2} + \frac{(\sigma_x - \sigma_y)}{2} \cdot \frac{(\sigma_x - \sigma_y)}{\sqrt{(\sigma_x - \sigma_y)^2 + 4\tau_{xy}^2}} \\ &\quad + \frac{\tau_{xy} \cdot 2\tau_{xy}}{\sqrt{(\sigma_x - \sigma_y)^2 + 4\tau_{xy}^2}} \\ &= \frac{(\sigma_x + \sigma_y)}{2} + \frac{1}{2} \cdot \frac{(\sigma_x - \sigma_y)^2}{\sqrt{(\sigma_x - \sigma_y)^2 + 4\tau_{xy}^2}} \\ &\quad + \frac{1}{2} \cdot \frac{4\tau_{xy}^2}{\sqrt{(\sigma_x - \sigma_y)^2 + 4\tau_{xy}^2}}\end{aligned}$$

or

$$\begin{aligned}&= \frac{(\sigma_x + \sigma_y)}{2} + \frac{1}{2} \cdot \frac{(\sigma_x - \sigma_y)^2 + 4\tau_{xy}^2}{\sqrt{(\sigma_x - \sigma_y)^2 + 4\tau_{xy}^2}} \\ &= \frac{1}{2}(\sigma_x + \sigma_y) \pm \frac{1}{2} \cdot \frac{\sqrt{(\sigma_x - \sigma_y)^2 + 4\tau_{xy}^2} \cdot \sqrt{(\sigma_x - \sigma_y)^2 + 4\tau_{xy}^2}}{\sqrt{(\sigma_x - \sigma_y)^2 + 4\tau_{xy}^2}} \\ \sigma_{\theta} &= \frac{1}{2}(\sigma_x + \sigma_y) \pm \frac{1}{2} \sqrt{(\sigma_x - \sigma_y)^2 + 4\tau_{xy}^2}\end{aligned}$$

Hence we get the two values of σ_{θ} , which are designated σ_1 as σ_2 and respectively, therefore

$$\begin{aligned}\sigma_1 &= \frac{1}{2}(\sigma_x + \sigma_y) + \frac{1}{2} \sqrt{(\sigma_x - \sigma_y)^2 + 4\tau_{xy}^2} \\ \sigma_2 &= \frac{1}{2}(\sigma_x + \sigma_y) - \frac{1}{2} \sqrt{(\sigma_x - \sigma_y)^2 + 4\tau_{xy}^2}\end{aligned}$$

The σ_1 and σ_2 are termed as the principle stresses of the system.

Substituting the values of $\cos 2\theta$ and $\sin 2\theta$ in equation (6) we see that

$$\begin{aligned}\tau_{\theta} &= \frac{1}{2}(\sigma_x - \sigma_y) \sin 2\theta - \tau_{xy} \cos 2\theta \\ &= \frac{1}{2}(\sigma_x - \sigma_y) \cdot \frac{2\tau_{xy}}{\sqrt{(\sigma_x - \sigma_y)^2 + 4\tau_{xy}^2}} - \frac{\tau_{xy} \cdot (\sigma_x - \sigma_y)}{\sqrt{(\sigma_x - \sigma_y)^2 + 4\tau_{xy}^2}}\end{aligned}$$

$$\tau_{\theta} = 0$$

This shows that the values of shear stress is zero on the principal planes.

Hence the maximum and minimum values of normal stresses occur on planes of zero shearing stress. The maximum and minimum normal stresses are called the principal stresses, and the planes on which they act are called principal planes. The solution of equation

$$\tan 2\theta_p = \frac{2\tau_{xy}}{(\sigma_x - \sigma_y)}$$

will yield two values of 2θ separated by 180° i.e. two values of θ separated by 90° . Thus the two principal stresses occur on mutually perpendicular planes termed principal planes.

Therefore the two – dimensional complex stress system can now be reduced to the equivalent system of principal stresses.

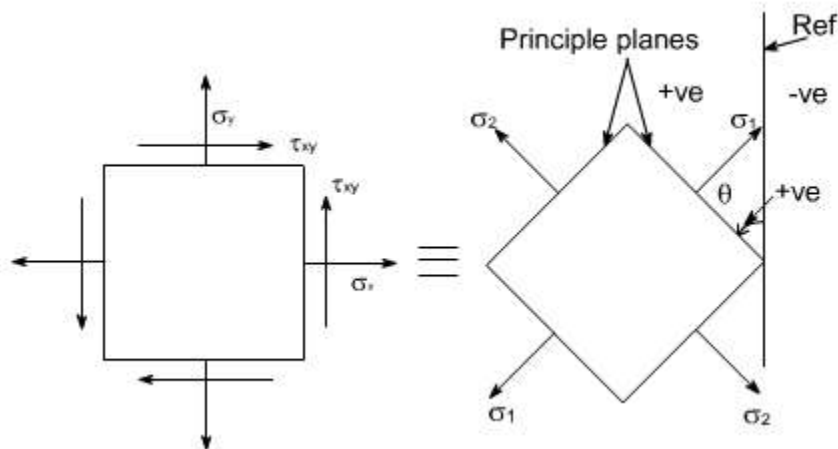

Let us recall that for the case of a material subjected to direct stresses the value of maximum shear stresses

$\tau_{\max}^m = \frac{1}{2}(\sigma_x - \sigma_y)$ at $\theta = 45^\circ$, Thus, for a 2-dimensional state of stress, subjected to principle st

$\tau_{\max}^m = \frac{1}{2}(\sigma_1 - \sigma_2)$, on substituting the values if σ_1 and σ_2 , we get

$$\tau_{\max}^m = \frac{1}{2}\sqrt{(\sigma_x - \sigma_y)^2 + 4\tau_{xy}^2}$$

Alternatively this expression can also be obtained by differentiating the expression for τ_θ with res

$$\tau_\theta = \frac{(\sigma_x - \sigma_y)}{2}\sin 2\theta - \tau_{xy}\cos 2\theta$$

$$\frac{d\tau_\theta}{d\theta} = -\frac{1}{2}(\sigma_x - \sigma_y)\cos 2\theta \cdot 2 + \tau_{xy}\sin 2\theta \cdot 2$$

$$= 0$$

$$\text{or } (\sigma_x - \sigma_y)\cos 2\theta + 2\tau_{xy}\sin 2\theta = 0$$

$$\tan 2\theta_s = \frac{(\sigma_y - \sigma_x)}{2\tau_{xy}} = -\frac{(\sigma_x - \sigma_y)}{2\tau_{xy}}$$

$$\tan 2\theta_s = -\frac{(\sigma_x - \sigma_y)}{2\tau_{xy}}$$

Re calling that

$$\tan 2\theta_p = \frac{2\tau_{xy}}{(\sigma_x - \sigma_y)}$$

Thus,

$$\boxed{\tan 2\theta_p \cdot \tan 2\theta_s = 1}$$

Therefore, it can be concluded that the equation (2) is a negative reciprocal of equation (1) hence the roots for the double angle of equation (2) are 90° away from the corresponding angle of equation (1).

This means that the angles that locate the plane of maximum or minimum shearing stresses form angles of 45° with the planes of principal stresses.

Further, by making the triangle we get

$$\cos 2\theta = \frac{2\tau_{xy}}{\sqrt{(\sigma_y - \sigma_x)^2 + 4\tau_{xy}^2}}$$

$$\sin 2\theta = \frac{-(\sigma_x - \sigma_y)}{\sqrt{(\sigma_y - \sigma_x)^2 + 4\tau_{xy}^2}}$$

Therefore by substituting the values of $\cos 2\theta$ and $\sin 2\theta$ we have

$$\begin{aligned} \tau_\theta &= \frac{1}{2}(\sigma_x - \sigma_y)\sin 2\theta - \tau_{xy}\cos 2\theta \\ &= \frac{1}{2} \cdot \frac{(\sigma_x - \sigma_y) \cdot (\sigma_x - \sigma_y)}{\sqrt{(\sigma_y - \sigma_x)^2 + 4\tau_{xy}^2}} - \frac{\tau_{xy} \cdot 2\tau_{xy}}{\sqrt{(\sigma_y - \sigma_x)^2 + 4\tau_{xy}^2}} \\ &= -\frac{1}{2} \cdot \frac{(\sigma_y - \sigma_x)^2 + 4\tau_{xy}^2}{\sqrt{(\sigma_y - \sigma_x)^2 + 4\tau_{xy}^2}} \\ \tau_\theta &= \pm \frac{1}{2} \sqrt{(\sigma_x - \sigma_y)^2 + 4\tau_{xy}^2} \end{aligned}$$

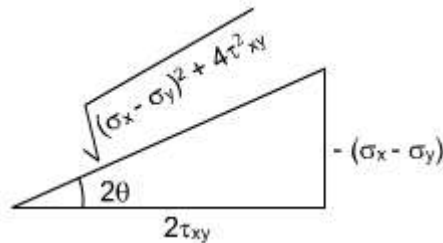

Because of root the difference in sign convention arises from the point of view of locating the planes on which shear stress act. From physical point of view these sign have no meaning.

The largest stress regard less of sign is always know as maximum shear stress.

Principal plane inclination in terms of associated principal stress:

$$\tan 2\theta_p = \frac{2\tau_{xy}}{(\sigma_x - \sigma_y)}$$

We know that the equation

yields two values of θ i.e. the inclination of the two principal planes on which the principal stresses σ_1 and σ_2 act. It is uncertain, however, which stress acts on which plane unless equation.

$$\sigma_\theta = \frac{(\sigma_x + \sigma_y)}{2} + \frac{(\sigma_x - \sigma_y)}{2} \cos 2\theta + \tau_{xy} \sin 2\theta$$

is used and observing which one of the two principal stresses is obtained.

Alternatively we can also find the answer to this problem in the following manner

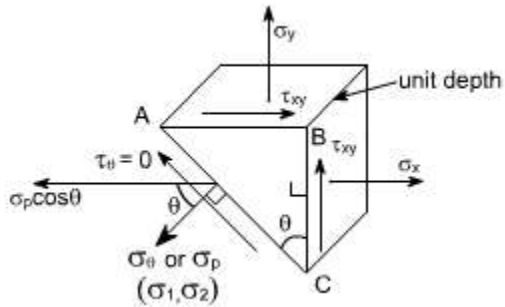

Consider once again the equilibrium of a triangular block of material of unit depth, Assuming AC to be a principal plane on which principal stresses σ_p acts, and the shear stress is zero.

Resolving the forces horizontally we get:

$\sigma_x \cdot BC \cdot 1 + \tau_{xy} \cdot AB \cdot 1 = \sigma_p \cdot \cos\theta \cdot AC$ dividing the above equation through by BC we get

$$\sigma_x + \tau_{xy} \frac{AB}{BC} = \sigma_p \cdot \cos\theta \cdot \frac{AC}{BC}$$

or

$$\sigma_x + \tau_{xy} \tan\theta = \sigma_p$$

Thus

$$\tan\theta = \frac{\sigma_p - \sigma_x}{\tau_{xy}}$$

LECTURE 5

GRAPHICAL SOLUTION – MOHR'S STRESS CIRCLE

The transformation equations for plane stress can be represented in a graphical form known as Mohr's circle. This graphical representation is very useful in depicting the relationships between normal and shear stresses acting on any inclined plane at a point in a stress body.

To draw a Mohr's stress circle consider a complex stress system as shown in the figure

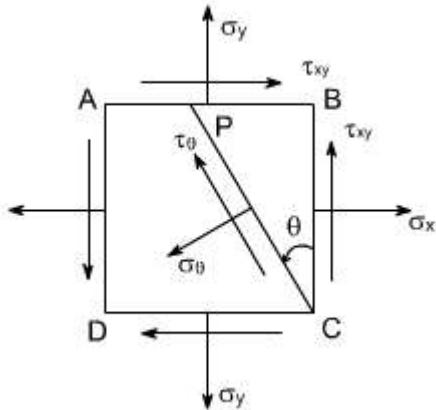

The above system represents a complete stress system for any condition of applied load in two dimensions

The Mohr's stress circle is used to find out graphically the direct stress s and shear stress t on any plane inclined at θ to the plane on which s_x acts. The direction of θ here is taken in anticlockwise direction from the BC.

STEPS:

In order to do achieve the desired objective we proceed in the following manner

- (i) Label the Block ABCD.
- (ii) Set up axes for the direct stress (as abscissa) and shear stress (as ordinate)
- (iii) Plot the stresses on two adjacent faces e.g. AB and BC, using the following sign convention.

Direct stresses - tensile positive; compressive, negative

Shear stresses – tending to turn block clockwise, positive

– tending to turn block counter clockwise, negative

[i.e shearing stresses are +ve when its movement about the centre of the element is clockwise]

This gives two points on the graph which may than be labeled as \overline{AB} and \overline{BC} respectively to denote stresses on these planes.

- (iv) Join \overline{AB} and \overline{BC} .

- (v) The point P where this line cuts the s axis is than the centre of Mohr's stress circle

and the line joining \overline{AB} and \overline{BC} is diameter. Therefore the circle can now be drawn.

Now every point on the circle then represents a state of stress on some plane through C.

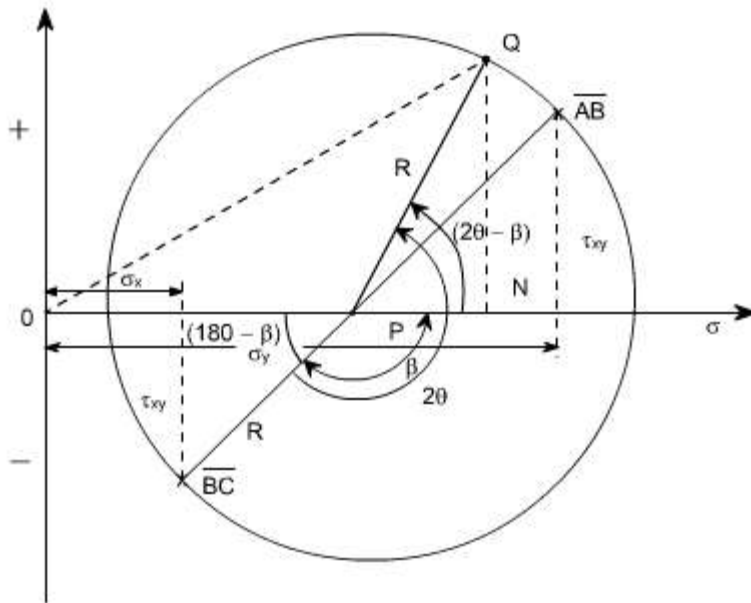

Proof:

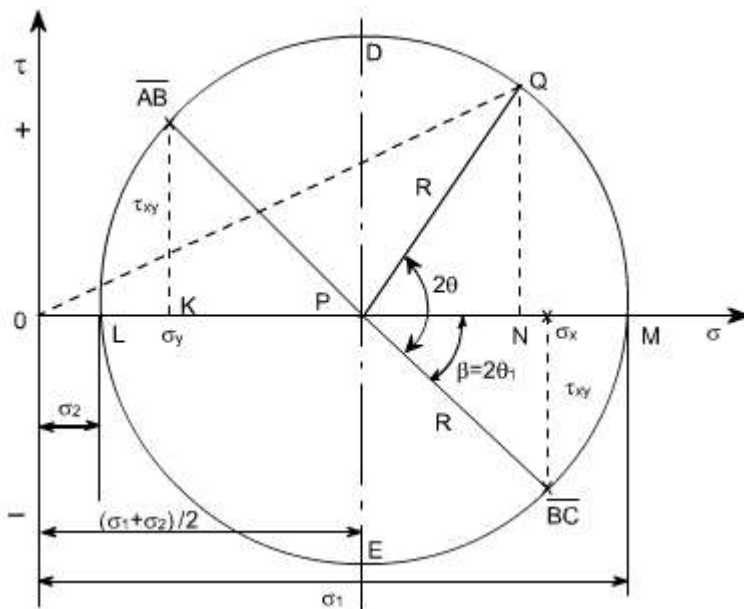

Consider any point Q on the circumference of the circle, such that PQ makes an angle $2q$ with BC, and drop a perpendicular from Q to meet the σ axis at N. Then OQ represents the resultant stress on the plane an angle q to BC. Here we have assumed that $\sigma_x > \sigma_y$

Now let us find out the coordinates of point Q. These are ON and QN.

From the figure drawn earlier

$$ON = OP + PN$$

$$OP = OK + KP$$

$$\begin{aligned} OP &= s_y + 1/2 (s_x - s_y) \\ &= s_y / 2 + s_y / 2 + s_x / 2 + s_y / 2 \\ &= (s_x + s_y) / 2 \end{aligned}$$

$$PN = R \cos(2q - b)$$

hence $ON = OP + PN$

$$\begin{aligned} &= (s_x + s_y) / 2 + R \cos(2q - b) \\ &= (s_x + s_y) / 2 + R \cos 2q \cos b + R \sin 2q \sin b \end{aligned}$$

now make the substitutions for $R \cos b$ and $R \sin b$.

$$R \cos b = \frac{(\sigma_x - \sigma_y)}{2}; R \sin b = \tau_{xy}$$

Thus,

$$ON = 1/2 (s_x + s_y) + 1/2 (s_x - s_y) \cos 2q + \tau_{xy} \sin 2q \quad (1)$$

Similarly $QM = R \sin(2q - b)$

$$= R \sin 2q \cos b - R \cos 2q \sin b$$

Thus, substituting the values of $R \cos b$ and $R \sin b$, we get

$$QM = 1/2 (s_x - s_y) \sin 2q - \tau_{xy} \cos 2q \quad (2)$$

If we examine the equation (1) and (2), we see that this is the same equation which we have already derived analytically

Thus the co-ordinates of Q are the normal and shear stresses on the plane inclined at q to BC in the original stress system.

N.B: Since angle $\widehat{BC}PQ$ is $2q$ on Mohr's circle and not q it becomes obvious that angles are doubled on Mohr's circle. This is the only difference, however, as they are measured in the same direction and from the same plane in both figures.

Further points to be noted are :

- (1) The direct stress is maximum when Q is at M and at this point obviously the shear stress is zero, hence by definition OM is the length representing the maximum principal stresses s_1 and $2q_1$ gives the angle of the plane q_1 from BC. Similar OL is the other principal stress and is represented by s_2
- (2) The maximum shear stress is given by the highest point on the circle and is represented by the radius of the circle.

This follows that since shear stresses and complimentary shear stresses have the same value; therefore the centre of the circle will always lie on the s axis midway between s_x and s_y . [since $+t_{xy}$ & $-t_{xy}$ are shear stress & complimentary shear stress so they are same in magnitude but different in sign.]

- (3) From the above point the maximum shear stress i.e. the Radius of the Mohr's stress circle would be

$$\frac{(\sigma_x - \sigma_y)}{2}$$

While the direct stress on the plane of maximum shear must be mid – may between s_x and s_y i.e

$$\frac{(\sigma_x + \sigma_y)}{2}$$

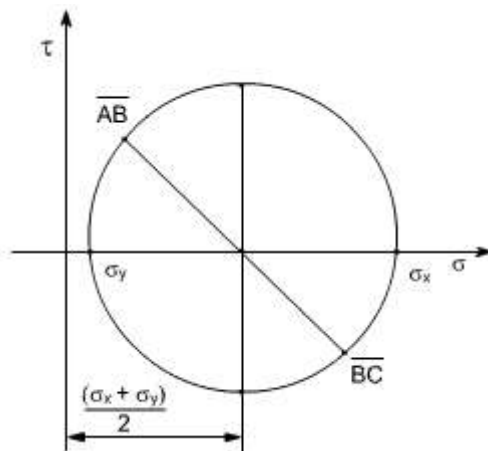

- (4) As already defined the principal planes are the planes on which the shear components are zero.

Therefore are conclude that on principal plane the shear stress is zero.

- (5) Since the resultant of two stress at 90° can be found from the parallogram of vectors

as shown in the diagram. Thus, the resultant stress on the plane at q to BC is given by OQ on Mohr's Circle.

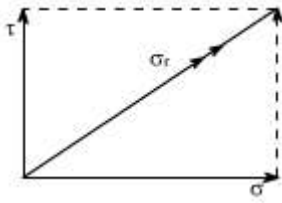

(6) The graphical method of solution for a complex stress problems using Mohr's circle is a very powerful technique, since all the information relating to any plane within the stressed element is contained in the single construction. It thus, provides a convenient and rapid means of solution. Which is less prone to arithmetical errors and is highly recommended.

LECTURE 6

ILLUSRATIVE PROBLEMS:

Let us discuss few representative problems dealing with complex state of stress to be solved either analytically or graphically.

PROB 1: A circular bar 40 mm diameter carries an axial tensile load of 105 kN. What is the Value of shear stress on the planes on which the normal stress has a value of 50 MN/m² tensile.

Solution:

$$\text{Tensile stress } s_y = F / A = 105 \times 10^3 / \pi \times (0.02)^2$$

$$= 83.55 \text{ MN/m}^2$$

Now the normal stress on an oblique plane is given by the relation

$$s_q = s_y \sin^2 q$$

$$50 \times 10^6 = 83.55 \text{ MN/m}^2 \times 10^6 \sin^2 q$$

$$q = 50^\circ 68'$$

The shear stress on the oblique plane is then given by

$$t_q = 1/2 s_y \sin 2q$$

$$= 1/2 \times 83.55 \times 10^6 \times \sin 101.36$$

$$= 40.96 \text{ MN/m}^2$$

Therefore the required shear stress is 40.96 MN/m^2

PROB 2:

For a given loading conditions the state of stress in the wall of a cylinder is expressed as follows:

- (a) 85 MN/m^2 tensile
- (b) 25 MN/m^2 tensile at right angles to (a)
- (c) Shear stresses of 60 MN/m^2 on the planes on which the stresses (a) and (b) act; the shear couple acting on planes carrying the 25 MN/m^2 stress is clockwise in effect.

Calculate the principal stresses and the planes on which they act. What would be the effect on these results if owing to a change of loading (a) becomes compressive while stresses (b) and (c) remain unchanged

Solution:

The problem may be attempted both analytically as well as graphically. Let us first obtain the analytical solution

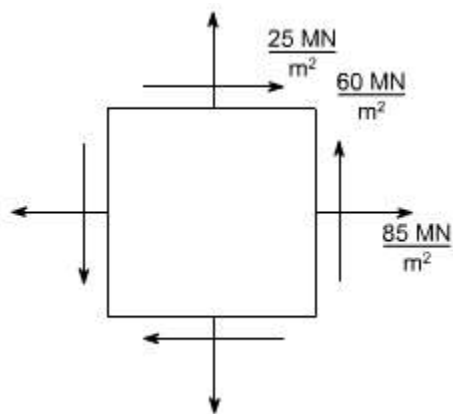

The principle stresses are given by the formula

$$\begin{aligned}
& \sigma_1 \text{ and } \sigma_2 \\
& = \frac{1}{2}(\sigma_x + \sigma_y) \pm \frac{1}{2}\sqrt{(\sigma_x - \sigma_y)^2 + 4\tau_{xy}^2} \\
& = \frac{1}{2}(85 + 25) \pm \frac{1}{2}\sqrt{(85 + 25)^2 + (4 \times 60^2)} \\
& = 55 \pm \frac{1}{2} \cdot 60\sqrt{5} = 55 \pm 67 \\
& \Rightarrow \sigma_1 = 122 \text{ MN/m}^2 \\
& \quad \sigma_2 = -12 \text{ MN/m}^2 \text{ (compressive)}
\end{aligned}$$

For finding out the planes on which the principle stresses act us the equation

$$\tan 2\theta = \left(\frac{2\tau_{xy}}{\sigma_x - \sigma_y} \right)$$

The solution of this equation will yeild two values q i.e they q_1 and q_2 giving $q_1 = 31^{\circ}71'$ & $q_2 = 121^{\circ}71'$

(b) In this case only the loading (a) is changed i.e. its direction had been changed. While the other stresses remains unchanged hence now the block diagram becomes.

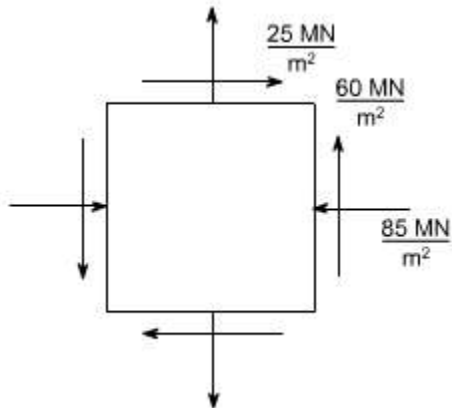

Again the principal stresses would be given by the equation.

$$\begin{aligned} \sigma_1 \& \sigma_2 &= \frac{1}{2}(\sigma_x + \sigma_y) \pm \frac{1}{2}\sqrt{(\sigma_x - \sigma_y)^2 + 4\tau_{xy}^2} \\ &= \frac{1}{2}(-85 + 25) \pm \frac{1}{2}\sqrt{(-85 - 25)^2 + (4 \times 60^2)} \\ &= \frac{1}{2}(-60) \pm \frac{1}{2}\sqrt{(-85 - 25)^2 + (4 \times 60^2)} \\ &= -30 \pm \frac{1}{2}\sqrt{12100 + 14400} \\ &= -30 \pm 81.4 \end{aligned}$$

$$\sigma_1 = 51.4 \text{ MN/m}^2; \sigma_2 = -111.4 \text{ MN/m}^2$$

Again for finding out the angles use the following equation.

$$\begin{aligned} \tan 2\theta &= \left(\frac{2\tau_{xy}}{\sigma_x - \sigma_y} \right) \\ &= \frac{2 \times 60}{-85 - 25} = + \frac{120}{-110} \\ &= -\frac{12}{11} \end{aligned}$$

$$2\theta = \tan^{-1}\left(-\frac{12}{11}\right)$$

$$\Rightarrow \theta = -23.74^\circ$$

Thus, the two principle stresses acting on the two mutually perpendicular planes i.e principle planes may be depicted on the element as shown below:

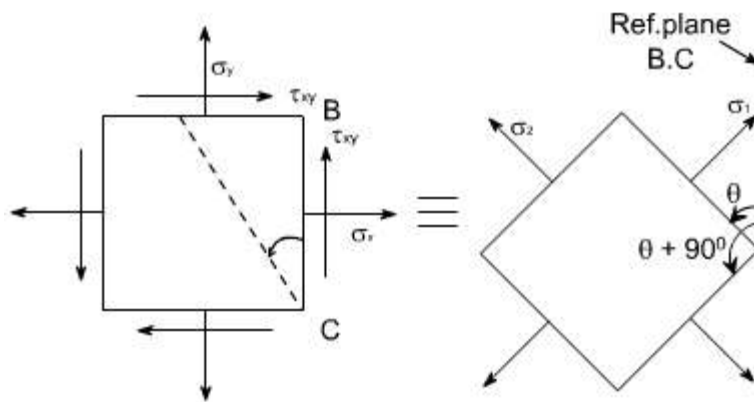

So this is the direction of one principle plane & the principle stresses acting on this would be σ_1 when is acting normal to this plane, now the direction of other principal plane would be $90^\circ + \theta$ because the principal planes are the two mutually perpendicular plane, hence rotate the another plane $\theta + 90^\circ$ in the same direction to get the another plane, now complete the material element if θ is negative that means we are measuring the angles in the opposite direction to the reference plane BC .

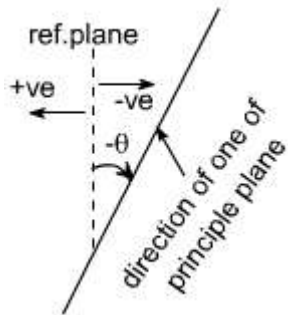

Therefore the direction of other principal planes would be $\{-q + 90\}$ since the angle $-q$ is always less in magnitude than 90 hence the quantity $(-q + 90)$ would be positive therefore the Inclination of other plane with reference plane would be positive therefore if just complete the Block. It would appear as

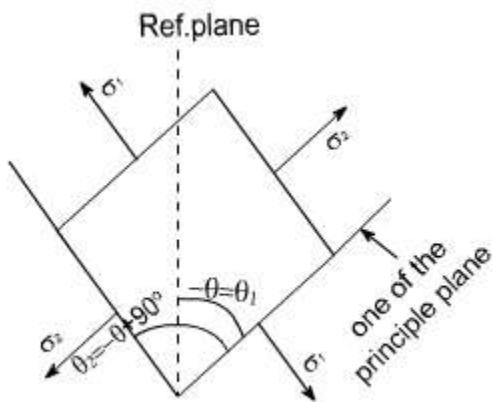

If we just want to measure the angles from the reference plane, than rotate this block through 180° so as to have the following appearance.

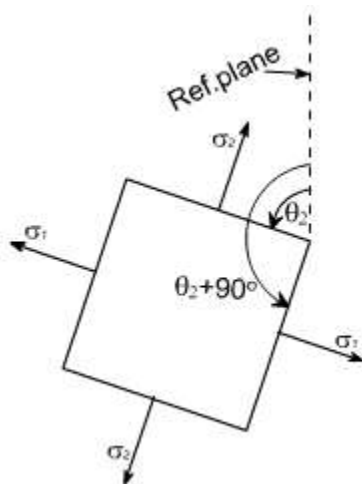

So whenever one of the angles comes negative to get the positive value,

first Add 90^0 to the value and again add 90^0 as in this case $q = -23^074'$

so $q_1 = -23^074' + 90^0 = 66^026'$.Again adding 90^0 also gives the direction of other principle planes

i.e $q_2 = 66^026' + 90^0 = 156^026'$

This is how we can show the angular position of these planes clearly.

GRAPHICAL SOLUTION:

Mohr's Circle solution: The same solution can be obtained using the graphical solution i.e the Mohr's stress circle,for the first part, the block diagram becomes

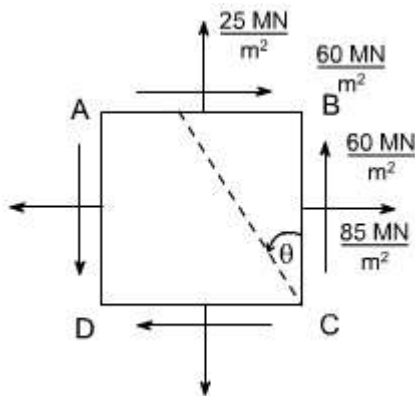

Construct the graphical construction as per the steps given earlier.

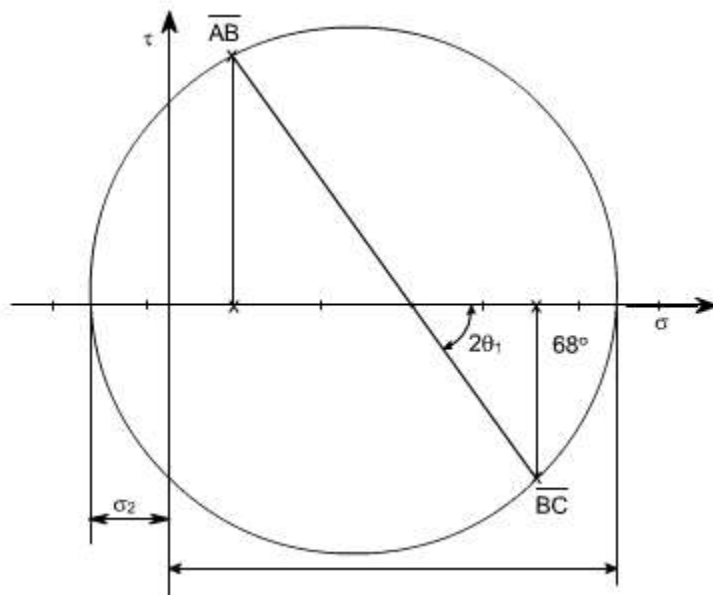

Taking the measurements from the Mohr's stress circle, the various quantities computed

are

$$s_1 = 120 \text{ MN/m}^2 \text{ tensile}$$

$$s_2 = 10 \text{ MN/m}^2 \text{ compressive}$$

$$q_1 = 34^\circ \text{ counter clockwise from BC}$$

$$q_2 = 34^\circ + 90 = 124^\circ \text{ counter clockwise from BC}$$

Part Second : The required configuration i.e the block diagram for this case is shown along with the stress circle.

By taking the measurements, the various quantities computed are given as

$$s_1 = 56.5 \text{ MN/m}^2 \text{ tensile}$$

$$s_2 = 106 \text{ MN/m}^2 \text{ compressive}$$

$$q_1 = 66^\circ 15' \text{ counter clockwise from BC}$$

$$q_2 = 156^\circ 15' \text{ counter clockwise from BC}$$

Salient points of Mohr's stress circle:

1. complementary shear stresses (on planes 90° apart on the circle) are equal in magnitude
2. The principal planes are orthogonal: points L and M are 180° apart on the circle (90°

apart in material)

3. There are no shear stresses on principal planes: point L and M lie on normal stress axis.
4. The planes of maximum shear are 45° from the principal points D and E are 90° , measured round the circle from points L and M.
5. The maximum shear stresses are equal in magnitude and given by points D and E
6. The normal stresses on the planes of maximum shear stress are equal i.e. points D and E both have normal stress co-ordinate which is equal to the two principal stresses.

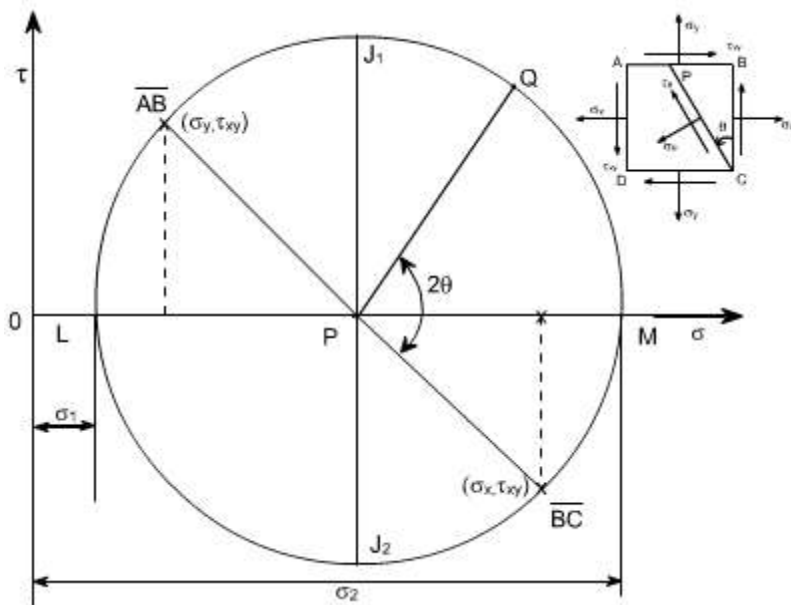

As we know that the circle represents all possible states of normal and shear stress on any plane through a stresses point in a material. Further we have seen that the co-ordinates of the point 'Q' are seen to be the same as those derived from equilibrium of the element. i.e. the normal and shear stress components on any plane passing through the point can be found using Mohr's circle. Worthy of note:

1. The sides AB and BC of the element ABCD, which are 90° apart, are represented on the circle by $\overline{AB} P$ and $\overline{BC} P$ and they are 180° apart.
2. It has been shown that Mohr's circle represents all possible states at a point. Thus, it can be seen at a point. Thus, it, can be seen that two planes LP and PM, 180° apart on the diagram and therefore 90° apart in the material, on which shear stress t_q is zero. These planes are termed as principal planes and normal stresses acting on them are known as principal stresses.

Thus , $s_1 = OL$

$$s_2 = OM$$

3. The maximum shear stress in an element is given by the top and bottom points of the circle i.e by points J_1 and J_2 , Thus the maximum shear stress would be equal to the radius of i.e. $t_{\max} = 1/2 (s_1 - s_2)$, the corresponding normal stress is obviously the distance $OP = 1/2 (s_x + s_y)$, Further it can also be seen that the planes on which the shear stress is maximum are situated 90° from the principal planes (on circle), and 45° in the material.

4. The minimum normal stress is just as important as the maximum. The algebraic minimum stress could have a magnitude greater than that of the maximum principal stress if the state of stress were such that the centre of the circle is to the left of origin.

i.e. if $s_1 = 20 \text{ MN/m}^2$ (say)

$$s_2 = -80 \text{ MN/m}^2 \text{ (say)}$$

$$\text{Then } t_{\max}^m = (s_1 - s_2 / 2) = 50 \text{ MN/m}^2$$

If should be noted that the principal stresses are considered a maximum or minimum mathematically e.g. a compressive or negative stress is less than a positive stress, irrespective of numerical value.

5. Since the stresses on perpendicular faces of any element are given by the co-ordinates of two diametrically opposite points on the circle, thus, the sum of the two normal stresses for any and all orientations of the element is constant, i.e. Thus sum is an invariant for any particular state of stress.

Sum of the two normal stress components acting on mutually perpendicular planes at a point in a state of plane stress is not affected by the orientation of these planes.

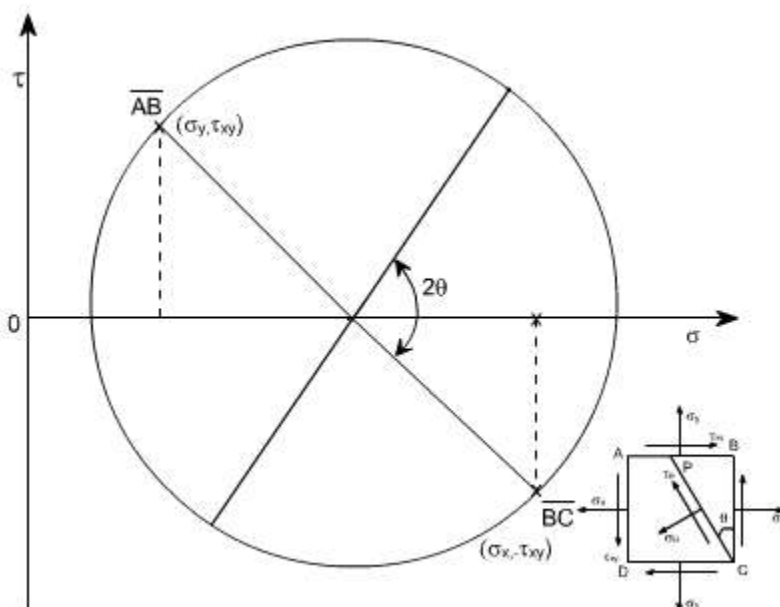

This can be also understand from the circle Since AB and BC are diametrically opposite thus, what ever may be their orientation, they will always lie on the diametre or we can say that their sum won't change, it can also be seen from analytical relations

We know
$$\sigma_n = \frac{(\sigma_x + \sigma_y)}{2} + \frac{(\sigma_x - \sigma_y)}{2} \cos 2\theta + \tau_{xy} \sin 2\theta$$

on plane BC; $q = 0$

$$s_{n1} = s_x$$

on plane AB; $q = 270^\circ$

$$s_{n2} = s_y$$

$$\text{Thus } s_{n1} + s_{n2} = s_x + s_y$$

6. If $s_1 = s_2$, the Mohr's stress circle degenerates into a point and no shearing stresses are developed on xy plane.

7. If $s_x + s_y = 0$, then the center of Mohr's circle coincides with the origin of s - t coordinates.

LECTURE 7

ANALYSIS OF STRAINS

CONCEPT OF STRAIN

Concept of strain : if a bar is subjected to a direct load, and hence a stress the bar will change in length. If the bar has an original length L and changes by an amount dL, the strain produce is defined as follows:

$$\text{strain}(\epsilon) = \frac{\text{change in length}}{\text{origin all length}} = \frac{\delta L}{L}$$

Strain is thus, a measure of the deformation of the material and is a nondimensional Quantity i.e. it has no units. It is simply a ratio of two quantities with the same unit.

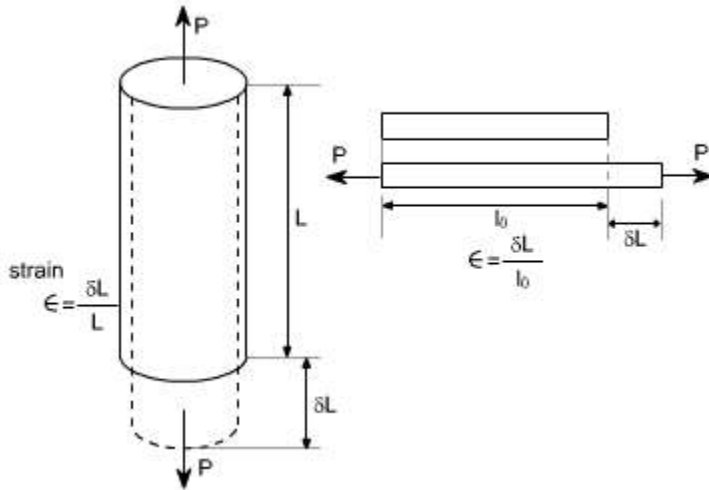

Since in practice, the extensions of materials under load are very very small, it is often convenient to measure the strain in the form of strain $\times 10^{-6}$ i.e. micro strain, when the symbol used becomes $\mu\epsilon$.

Sign convention for strain:

Tensile strains are positive whereas compressive strains are negative. The strain defined earlier was known as linear strain or normal strain or the longitudinal strain now let us define the shear strain.

Definition: An element which is subjected to a shear stress experiences a deformation as shown in the figure below. The tangent of the angle through which two adjacent sides rotate relative to their initial position is termed shear strain. In many cases the angle is very small and the angle itself is used, (in radians), instead of tangent, so that $\gamma = \angle AOB - \angle A'OB' = \phi$

Shear strain: As we know that the shear stresses acts along the surface. The action of the stresses is to produce or being about the deformation in the body consider the distortion produced by shear stress on an element or rectangular block

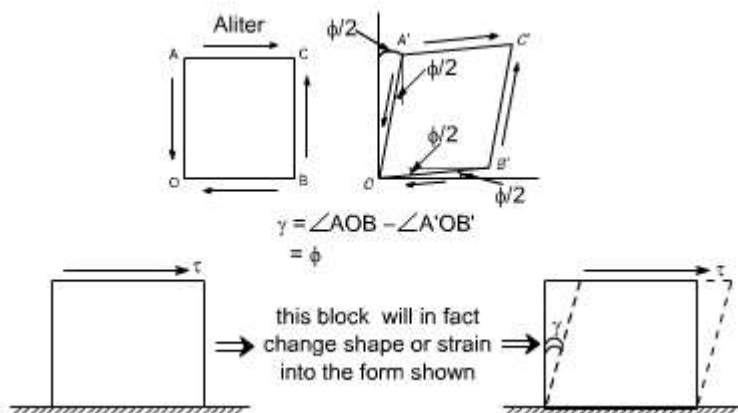

This shear strain or slide is f and can be defined as the change in right angle. or The angle of deformation g is then termed as the shear strain. Shear strain is measured in radians & hence is non – dimensional i.e. it has no unit. So we have two types of strain i.e. normal stress & shear stresses.

Hook's Law :

A material is said to be elastic if it returns to its original, unloaded dimensions when load is removed.

Hook's law therefore states that

Stress (s) a strain(\hat{I})

$$\frac{\text{stress}}{\text{strain}} = \text{constant}$$

Modulus of elasticity : Within the elastic limits of materials i.e. within the limits in which Hook's law applies, it has been shown that

$$\text{Stress / strain} = \text{constant}$$

This constant is given by the symbol E and is termed as the modulus of elasticity or Young's modulus of elasticity

$$E = \frac{\text{strain}}{\text{stress}} = \frac{\sigma}{\epsilon}$$

$$= P/A / \delta L/L$$

Thus
$$E = \frac{PL}{A\delta L}$$

The value of Young's modulus E is generally assumed to be the same in tension or compression and for most engineering material has high, numerical value of the order of 200 GPa

Poisson's ratio: If a bar is subjected to a longitudinal stress there will be a strain in this direction equal to s / E . There will also be a strain in all directions at right angles to s . The final shape being shown by the dotted lines.

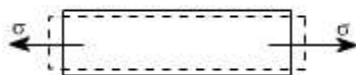

It has been observed that for an elastic materials, the lateral strain is proportional to the longitudinal strain. The ratio of the lateral strain to longitudinal strain is known as the poisson's ratio .

Poisson's ratio (μ) = - lateral strain / longitudinal strain

For most engineering materials the value of μ is between 0.25 and 0.33.

Three – dimensional state of strain : Consider an element subjected to three mutually perpendicular tensile stresses s_x , s_y and s_z as shown in the figure below.

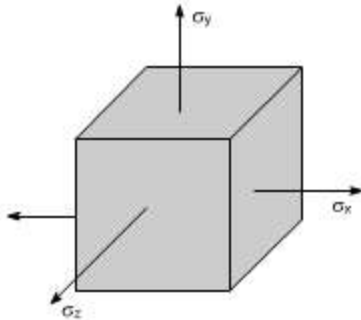

If s_y and s_z were not present the strain in the x direction from the basic definition of Young's modulus of Elasticity E would be equal to

$$\hat{\epsilon}_x = s_x / E$$

The effects of s_y and s_z in x direction are given by the definition of Poisson's ratio ' μ ' to be equal as $-\mu s_y / E$ and $-\mu s_z / E$

The negative sign indicating that if s_y and s_z are positive i.e. tensile, these they tend to reduce the strain in x direction thus the total linear strain in x direction is given by

$$\epsilon_x = \frac{\sigma_x}{E} - \mu \frac{\sigma_y}{E} - \mu \frac{\sigma_z}{E}$$

$$\epsilon_y = \frac{\sigma_y}{E} - \mu \frac{\sigma_x}{E} - \mu \frac{\sigma_z}{E}$$

$$\epsilon_z = \frac{\sigma_z}{E} - \mu \frac{\sigma_y}{E} - \mu \frac{\sigma_x}{E}$$

Principal strains in terms of stress:

In the absence of shear stresses on the faces of the elements let us say that s_x , s_y , s_z are in fact the principal stress. The resulting strain in the three directions would be the principal strains.

$$\epsilon_1 = \frac{1}{E} [\sigma_1 - \mu \sigma_2 - \mu \sigma_3]$$

$$\epsilon_2 = \frac{1}{E} [\sigma_2 - \mu \sigma_1 - \mu \sigma_3]$$

$$\epsilon_3 = \frac{1}{E} [\sigma_3 - \mu \sigma_1 - \mu \sigma_2]$$

i.e. We will have the following relation.

For Two dimensional strain: system, the stress in the third direction becomes zero i.e $s_z = 0$ or $s_3 = 0$

Although we will have a strain in this direction owing to stresses s_1 & s_2 .

$$\epsilon_1 = \frac{1}{E} [\sigma_1 - \mu \sigma_2]$$

$$\epsilon_2 = \frac{1}{E} [\sigma_2 - \mu \sigma_1]$$

$$\epsilon_3 = \frac{1}{E} [-\mu \sigma_1 - \mu \sigma_2]$$

Hence the set of equation as described earlier reduces to

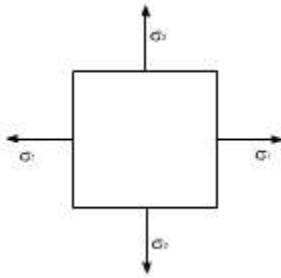

Hence a strain can exist without a stress in that direction

i.e if $\sigma_3 = 0$; $\epsilon_3 = \frac{1}{E} [-\mu \sigma_1 - \mu \sigma_2]$

Also

$$\epsilon_1 . E = \sigma_1 - \mu \sigma_2$$

$$\epsilon_2 . E = \sigma_2 - \mu \sigma_1$$

so the solution of above two equations yields

$$\sigma_1 = \frac{E}{(1 - \mu^2)} [\epsilon_1 + \mu \epsilon_2]$$

$$\sigma_2 = \frac{E}{(1 - \mu^2)} [\epsilon_2 + \mu \epsilon_1]$$

Hydrostatic stress : The term Hydrostatic stress is used to describe a state of tensile or compressive stress equal in all directions within or external to a body. Hydrostatic stress causes a change in volume of a material, which if expressed per unit of original volume gives a volumetric strain denoted by \hat{I}_v . So let us determine the expression for the volumetric strain.

Volumetric Strain:

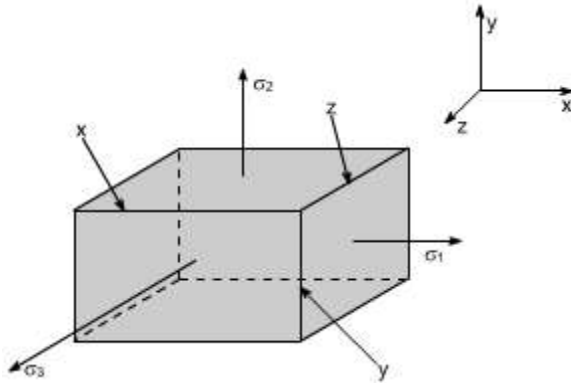

Consider a rectangle solid of sides x , y and z under the action of principal stresses s_1 , s_2 , s_3 respectively.

Then \hat{I}_1 , \hat{I}_2 , and \hat{I}_3 are the corresponding linear strains, than the dimensions of the rectangle becomes

$$(x + \hat{I}_1 \cdot x); (y + \hat{I}_2 \cdot y); (z + \hat{I}_3 \cdot z)$$

hence

$$\begin{aligned} \text{Volumetric strain} &= \frac{\text{Increase in volume}}{\text{Original volume}} \\ &= \frac{x(1 + \epsilon_1)y(1 + \epsilon_2)(1 + \epsilon_3)z - xyz}{xyz} \end{aligned}$$

$$\text{the} \quad = (1 + \epsilon_1)y(1 + \epsilon_2)(1 + \epsilon_3) - 1 \cong \epsilon_1 + \epsilon_2 + \epsilon_3 \quad \left[\text{Neglecting the products of } \epsilon^{i\epsilon} \right]$$

ALITER : Let a cuboid of material having initial sides of Length x , y and z . If under some load system, the sides changes in length by dx , dy , and dz then the new volume $(x + dx)(y + dy)(z + dz)$

$$\text{New volume} = xyz + yzdx + xzdy + xydz$$

$$\text{Original volume} = xyz$$

$$\text{Change in volume} = yzdx + xzdy + xydz$$

$$\text{Volumetric strain} = (yzdx + xzdy + xydz) / xyz = \hat{I}_x + \hat{I}_y + \hat{I}_z$$

Neglecting the products of epsilon's since the strains are sufficiently small.

Volumetric strains in terms of principal stresses:

As we know that

$$\epsilon_1 = \frac{\sigma_1}{E} - \mu \frac{\sigma_2}{E} - \mu \frac{\sigma_3}{E}$$

$$\epsilon_2 = \frac{\sigma_2}{E} - \mu \frac{\sigma_1}{E} - \mu \frac{\sigma_3}{E}$$

$$\epsilon_3 = \frac{\sigma_3}{E} - \mu \frac{\sigma_1}{E} - \mu \frac{\sigma_2}{E}$$

Further Volumetric strain = $\epsilon_1 + \epsilon_2 + \epsilon_3$

$$= \frac{(\sigma_1 + \sigma_2 + \sigma_3)}{E} - \frac{2\mu(\sigma_1 + \sigma_2 + \sigma_3)}{E}$$

$$= \frac{(\sigma_1 + \sigma_2 + \sigma_3)(1 - 2\mu)}{E}$$

hence the

$\text{Volumetric strain} = \frac{(\sigma_1 + \sigma_2 + \sigma_3)(1 - 2\mu)}{E}$

Strains on an oblique plane

(a) Linear strain

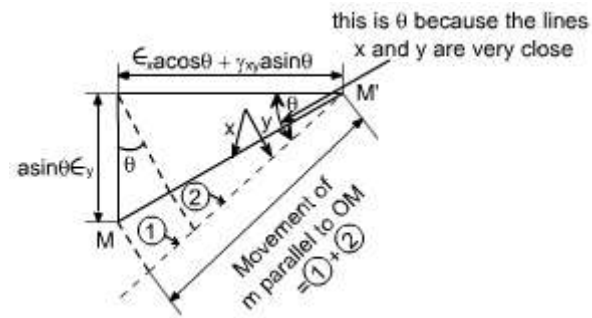
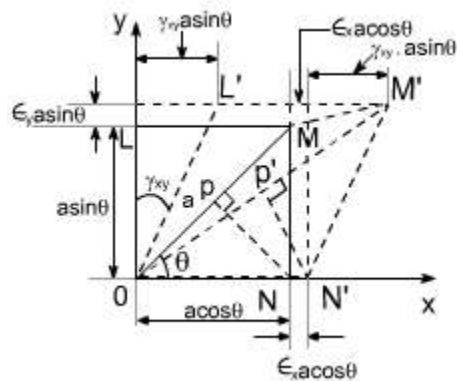

Consider a rectangular block of material OLMN as shown in the xy plane. The strains along ox and oy are $\hat{\epsilon}_x$ and $\hat{\epsilon}_y$, and g_{xy} is the shearing strain.

Then it is required to find an expression for $\hat{\epsilon}_q$, i.e the linear strain in a direction inclined at q to OX , in terms of $\hat{\epsilon}_x$, $\hat{\epsilon}_y$, g_{xy} and q .

Let the diagonal OM be of length 'a' then $ON = a \cos q$ and $OL = a \sin q$, and the increase in length of those under strains are $\hat{\epsilon}_x a \cos q$ and $\hat{\epsilon}_y a \sin q$ (i.e. strain x original length) respectively.

If M moves to M' , then the movement of M parallel to x axis is $\hat{\epsilon}_x a \cos q + g_{xy} \sin q$ and the movement parallel to the y axis is $\hat{\epsilon}_y a \sin q$

Thus the movement of M parallel to OM , which since the strains are small is practically coincident with MM' . and this would be the summation of portions (1) and (2) respectively and is equal to

$$= (\epsilon_y a \sin \theta) \sin \theta + (\epsilon_x a \cos \theta + \gamma_{xy} a \sin \theta) \cos \theta$$

$$= a [\epsilon_y \sin \theta \cdot \sin \theta + \epsilon_x \cos \theta \cdot \cos \theta + \gamma_{xy} \sin \theta \cdot \cos \theta]$$

hence the strain along OM

$$= \frac{\text{extension}}{\text{original length}}$$

$$\epsilon_\theta = \epsilon_x \cos^2 \theta + \gamma_{xy} \sin \theta \cdot \cos \theta + \epsilon_y \sin^2 \theta$$

$$\epsilon_\theta = \epsilon_x \cos^2 \theta + \epsilon_y \sin^2 \theta + \gamma_{xy} \sin \theta \cdot \cos \theta$$

$$\text{Recalling } \cos^2 \theta - \sin^2 \theta = \cos 2\theta$$

$$\text{or } 2 \cos^2 \theta - 1 = \cos 2\theta$$

$$\cos^2 \theta = \left[\frac{1 + \cos 2\theta}{2} \right]$$

$$\sin^2 \theta = \left[\frac{1 - \cos 2\theta}{2} \right]$$

hence

$$\epsilon_\theta = \epsilon_x \left[\frac{1 + \cos 2\theta}{2} \right] + \epsilon_y \left[\frac{1 - \cos 2\theta}{2} \right] + \gamma_{xy} a \sin \theta \cdot \cos \theta$$

$$= \frac{\epsilon_x + \epsilon_y}{2} + \frac{\epsilon_x - \epsilon_y}{2} \cos 2\theta + \frac{1}{2} \gamma_{xy} \sin 2\theta$$

$$\epsilon_\theta = \left\{ \frac{\epsilon_x + \epsilon_y}{2} \right\} + \left\{ \frac{\epsilon_x - \epsilon_y}{2} \right\} \cos 2\theta + \frac{1}{2} \gamma_{xy} \sin 2\theta$$

This expression is identical in form with the equation defining the direct stress on any inclined plane q with \hat{I}_x and \hat{I}_y replacing s_x and s_y and $\frac{1}{2} g_{xy}$ replacing t_{xy} i.e. the shear stress is replaced by half the shear strain

Shear strain: To determine the shear strain in the direction OM consider the displacement of point P at the foot of the perpendicular from N to OM and the following expression

$$\text{can be derived as } \frac{1}{2} \gamma_\theta = - \left[\frac{1}{2} (\epsilon_x - \epsilon_y) \sin 2\theta - \frac{1}{2} \gamma_{xy} \cos 2\theta \right]$$

In the above expression $\frac{1}{2}$ is there so as to keep the consistency with the stress relations.

Further -ve sign in the expression occurs so as to keep the consistency of sign convention, because OM' moves clockwise with respect to OM it is considered to be negative strain.

The other relevant expressions are the following :

Principal planes :

$$\tan 2\theta_p = \frac{\gamma_{xy}}{\epsilon_x - \epsilon_y}$$

Principal strains :

$$\epsilon_{1,2} = \frac{\epsilon_x + \epsilon_y}{2} \pm \sqrt{\left(\frac{\epsilon_x - \epsilon_y}{2}\right)^2 + \left(\frac{\gamma_{xy}}{2}\right)^2}$$

Maximum shear strains :

$$\frac{\gamma_{\max}}{2} = \pm \sqrt{\left(\frac{\epsilon_x - \epsilon_y}{2}\right)^2 + \left(\frac{\gamma_{xy}}{2}\right)^2}$$

Let us now define the plane strain condition

Plane Strain :

In xy plane three strain components may exist as can be seen from the following figures:

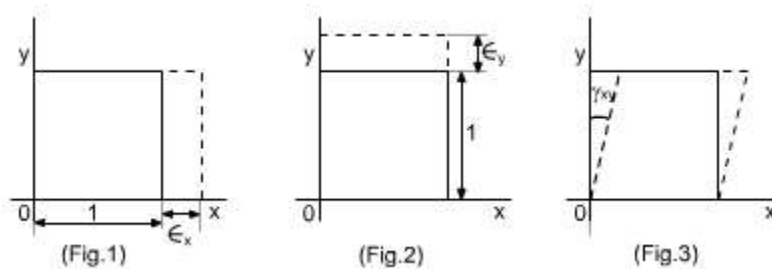

Therefore, a strain at any point in body can be characterized by two axial strains i.e \hat{I}_x in x direction, \hat{I}_y in y - direction and g_{xy} the shear strain.

In the case of normal strains subscripts have been used to indicate the direction of the strain, and \hat{I}_x , \hat{I}_y are defined as the relative changes in length in the co-ordinate directions.

With shear strains, the single subscript notation is not practical, because such strains involves displacements and length which are not in same direction. The symbol and subscript g_{xy} used for the shear strain referred to the x and y planes. The order of the subscript is unimportant. g_{xy} and g_{yx} refer to the same physical quantity. However, the sign convention is important. The shear strain g_{xy} is considered to be positive if it represents a decrease the angle between the sides of an element of material lying parallel the positive x and y axes. Alternatively we can think of positive shear strains produced by the positive shear stresses and viceversa.

Plane strain :

An element of material subjected only to the strains as shown in Fig. 1, 2, and 3 respectively is termed as the plane strain state.

Thus, the plane strain condition is defined only by the components $\hat{I}_x, \hat{I}_y, g_{xy} : \hat{I}_z = 0; g_{xz} = 0; g_{yz} = 0$

It should be noted that the plane stress is not the stress system associated with plane strain. The plane strain condition is associated with three dimensional stress system and plane stress is associated with three dimensional strain system.

LECTURE 8

PRINCIPAL STRAIN

For the strains on an oblique plane we have an oblique we have two equations which are identical in form with the equation defining the direct stress on any inclined plane q .

$$\epsilon_{\theta} = \left\{ \frac{\epsilon_x + \epsilon_y}{2} \right\} + \left\{ \frac{\epsilon_x - \epsilon_y}{2} \right\} \cos 2\theta + \frac{1}{2} \gamma_{xy} \sin 2\theta$$

$$\frac{1}{2} \gamma_{\theta} = - \left[\frac{1}{2} (\epsilon_x - \epsilon_y) \sin 2\theta - \frac{1}{2} \gamma_{xy} \cos 2\theta \right]$$

Since the equations for stress and strains on oblique planes are identical in form, so it is evident that Mohr's stress circle construction can be used equally well to represent strain conditions using the horizontal axis for linear strains and the vertical axis for half the shear strain.

It should be noted, however that the angles given by Mohr's stress circle refer to the directions of the planes on which the stress act and not the direction of the stresses themselves.

The direction of the stresses and therefore associated strains are therefore normal (i.e. at 90°) to the directions of the planes. Since angles are doubled in Mohr's stress circle construction it follows therefore that for a true similarity of working a relative rotation of axes of $2 \times 90^\circ = 180^\circ$ must be introduced. This is achieved by plotting positive shear strains vertically downwards on the strain circle construction.

The sign convention adopted for the strains is as follows:

Linear Strains : extension - positive

compression - negative

{ Shear of strains are taken positive, when they increase the original right angle of an unstrained element. }

Shear strains : for Mohr's strains circle shear strain g_{xy} - is +ve referred to x - direction

the convention for the shear strains are bit difficult. The first subscript in the symbol g_{xy} usually denotes the shear strains associated with direction. e.g. in g_{xy} represents the shear strain in x - direction and for g_{yx} represents the shear strain in y - direction. If under strain the line associated with first subscript moves counter clockwise with respect to the other line, the shearing strain is said to be positive, and if it moves clockwise it is said to be negative.

N.B: The positive shear strain is always to be drawn on the top of \hat{I}_x . [If the shear strain g_{xy} is given]

Moh's strain circle

For the plane strain conditions can we derive the following relations

$$\epsilon_{\theta} = \left\{ \frac{\epsilon_x + \epsilon_y}{2} \right\} + \left\{ \frac{\epsilon_x - \epsilon_y}{2} \right\} \cos 2\theta + \frac{1}{2} \gamma_{xy} \sin 2\theta \quad (1)$$

$$\frac{1}{2} \gamma_{\theta} = - \left[\frac{1}{2} (\epsilon_x - \epsilon_y) \sin 2\theta - \frac{1}{2} \gamma_{xy} \cos 2\theta \right] \quad (2)$$

Re writing the equation (1) as below :

$$\left[\epsilon_{\theta} - \left(\frac{\epsilon_x + \epsilon_y}{2} \right) \right] = \left\{ \frac{\epsilon_x - \epsilon_y}{2} \right\} \cos 2\theta + \frac{1}{2} \gamma_{xy} \sin 2\theta \quad (3)$$

squaring and adding equations (2) and (3)

$$\left[\epsilon_{\theta} - \left(\frac{\epsilon_x + \epsilon_y}{2} \right) \right]^2 + \left\{ \frac{1}{2} \gamma_{\theta} \right\}^2 = \left[\left\{ \frac{\epsilon_x - \epsilon_y}{2} \right\} \cos 2\theta + \frac{1}{2} \gamma_{xy} \sin 2\theta \right]^2 + \left[\frac{1}{2} (\epsilon_x - \epsilon_y) \sin 2\theta - \frac{1}{2} \gamma_{xy} \cos 2\theta \right]^2$$

$$\left[\epsilon_{\theta} - \left(\frac{\epsilon_x + \epsilon_y}{2} \right) \right]^2 + \left\{ \frac{1}{2} \gamma_{\theta} \right\}^2 = \left(\frac{\epsilon_x + \epsilon_y}{2} \right)^2 + \frac{\gamma_{xy}^2}{4}$$

Now as we know that

$$\epsilon_{1,2} = \frac{\epsilon_x + \epsilon_y}{2} \pm \sqrt{\left(\frac{\epsilon_x - \epsilon_y}{2} \right)^2 + \left(\frac{\gamma_{xy}}{2} \right)^2}$$

$$\epsilon_1 + \epsilon_2 = \epsilon_x + \epsilon_y$$

$$\left(\frac{\epsilon_1 - \epsilon_2}{2} \right)^2 = \left(\frac{\epsilon_x - \epsilon_y}{2} \right)^2 + \frac{\gamma_{xy}^2}{4}$$

Therefore the equation get transformed to

$$\left[\epsilon_{\theta} - \left(\frac{\epsilon_1 + \epsilon_2}{2} \right) \right]^2 + \left[\frac{\gamma_{\theta}}{2} \right]^2 = \left(\frac{\epsilon_1 - \epsilon_2}{2} \right)^2 \quad (4)$$

If we plot equation (4) we obtain a circle of radius $\left(\frac{\epsilon_1 - \epsilon_2}{2} \right)$ with center at $\left(\frac{\epsilon_1 + \epsilon_2}{2}, 0 \right)$

A typical point P on the circle given the normal strain and half the shear strain $1/2 g_{xy}$

associated with a particular plane. We note again that an angle subtended at the centre of Mohr's circle by an arc connecting two points on the circle is twice the physical angle in the material.

Mohr strain circle :

Since the transformation equations for plane strain are similar to those for plane stress, we can employ a similar form of pictorial representation. This is known as Mohr's strain circle.

The main difference between Mohr's stress circle and stress circle is that a factor of half is attached to the shear strains.

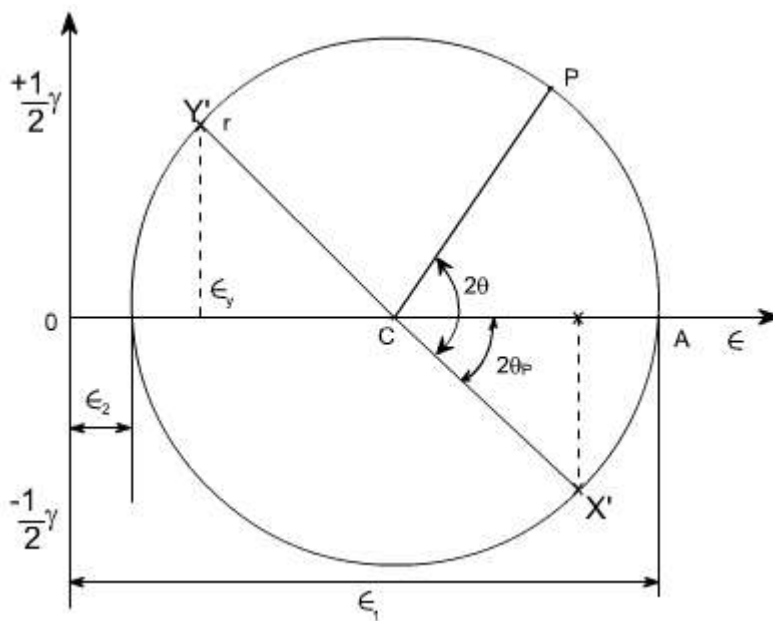

Points X' and Y' represents the strains associated with x and y directions with \hat{I} and $g_{xy} / 2$ as co-ordinates

Co-ordinates of X' and Y' points are located as follows :

$$X' = \left(\epsilon_x, -\frac{\gamma_{xy}}{2} \right)$$

$$Y' = \left(\epsilon_y, +\frac{\gamma_{xy}}{2} \right)$$

In x – direction, the strains produced, the strains produced by s_x , and $-t_{xy}$ are \hat{I}_x and $-g_{xy} / 2$

where as in the Y - direction, the strains are produced by \hat{I}_y and $+g_{xy}$ are produced by s_y and $+t_{xy}$

These co-ordinated are consistent with our sign notation (i.e. + ve shear stresses produces produce +ve shear strain & vice versa)

on the face AB is $t_{xy} +ve$ i.e strains are $(\hat{I}_y, +g_{xy}/2)$ where as on the face BC, t_{xy} is negative hence the strains are $(\hat{I}_x, - g_{xy}/2)$

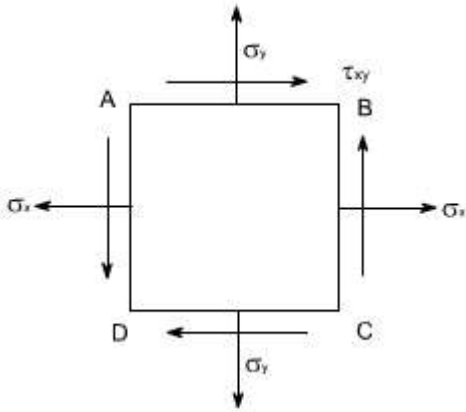

A typical point P on the circle gives the normal strains and half the shear strain, associated with a particular plane we must measure the angle from x – axis (taken as reference) as the required formulas for $\hat{I}_q, -1/2 g_q$ have been derived with reference to x-axis with angle measuring in the c.c.W direction

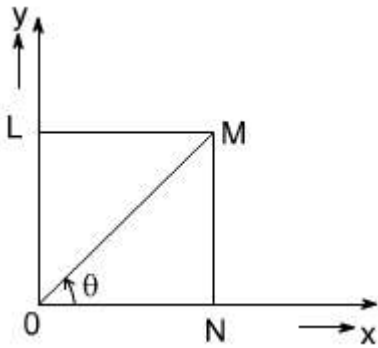

CONSTRUCTION :

In this we would like to locate the points x' & y' instead of AB and BC as we have done in the case of Mohr's stress circle.

steps

1. Take normal or linear strains on x-axis, whereas half of shear strains are plotted on y-axis.
2. Locate the points x' and y'

3. Join x' and y' and draw the Mohr's strain circle
4. Measure the required parameter from this construction.

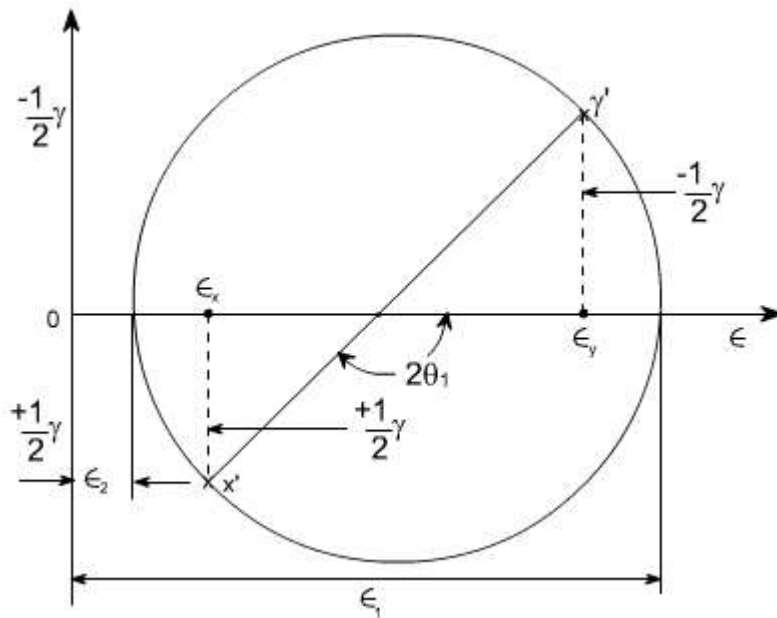

Note: positive shear strains are associated with planes carrying positive shear stresses and negative strains with planes carrying negative shear stresses.

ILLUSTRATIVE EXAMPLES :

1. At a certain point, a material is subjected to the following state of strains:

$$\hat{I}_x = 400 \times 10^{-6} \text{ units}$$

$$\hat{I}_y = 200 \times 10^{-6} \text{ units}$$

$$g_{xy} = 350 \times 10^{-6} \text{ radians}$$

Determine the magnitudes of the principal strains, the direction of the principal strains axes and the strain on an axis inclined at 30° clockwise to the x – axis.

Solution:

Draw the Mohr's strain circle by locating the points x' and y'

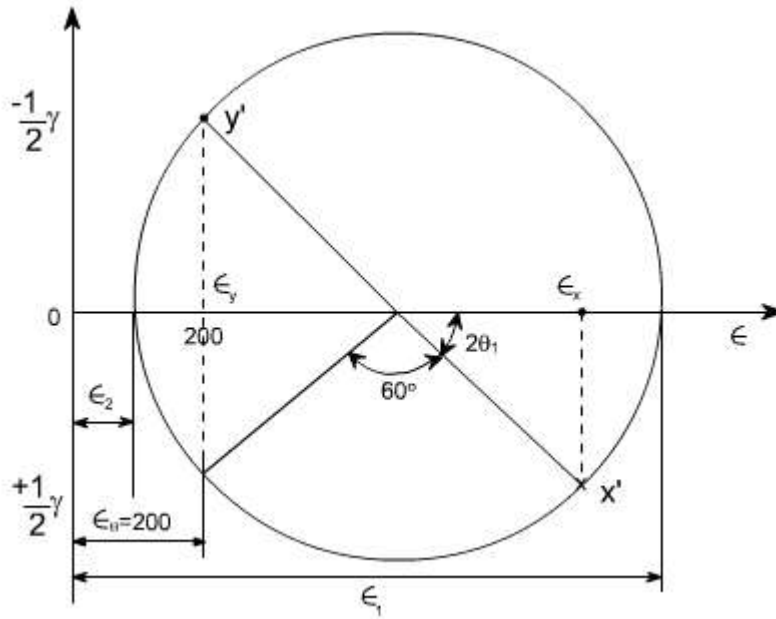

By Measurement the following values may be computed

$$\hat{\epsilon}_1 = 500 \times 10^{-6} \text{ units}$$

$$\hat{\epsilon}_2 = 100 \times 10^{-6} \text{ units}$$

$$q_1 = 60^\circ / 2 = 30^\circ$$

$$q_2 = 90 + 30 = 120^\circ$$

$$\hat{\epsilon}_{30} = 200 \times 10^{-6} \text{ units}$$

The angles being measured c.c.w. from the direction of $\hat{\epsilon}_x$.

PROB 2.

A material is subjected to two mutually perpendicular strains $\hat{\epsilon}_x = 350 \times 10^{-6}$ units and $\hat{\epsilon}_y = 50 \times 10^{-6}$ units together with an unknown shear strain g_{xy} if the principal strain in the material is 420×10^{-6} units Determine the following.

- Magnitude of the shear strain
- The other principal strain
- The direction of principal strains axes
- The magnitude of the principal stresses

$$\text{If } E = 200 \text{ GN / m}^2; \nu = 0.3$$

Solution :

The Mohr's strain circle can be drawn as per the procedure described earlier. from the graphical construction, the following results may be obtained :

(i) Shear strain $\gamma_{xy} = 324 \times 10^{-6}$ radians

(ii) other principal strain = -20×10^{-6}

(iii) direction of principal strain = $47^\circ / 2 = 23^\circ 30'$

(iv) direction of other principal strain = $90^\circ + 23^\circ 30' = 113^\circ 30'$

In order to determine the magnitude of principle stresses, the computed values of \hat{I}_1 and \hat{I}_2 from the graphical construction may be substituted in the following expressions

$$\sigma_1 = \frac{(\epsilon_1 + \gamma\epsilon_2)}{(1 - \gamma^2)} \cdot E = 91 \frac{\text{MN}}{\text{m}^2}$$

$$\sigma_2 = \frac{(\epsilon_2 + \gamma\epsilon_1)}{(1 - \gamma^2)} \cdot E = 23 \frac{\text{MN}}{\text{m}^2}$$

Use of strain Gauges :

Although we can not measure stresses within a structural member, we can measure strains, and from them the stresses can be computed, Even so, we can only measure strains on the surface. For example, we can mark points and lines on the surface and measure changes in their spacing angles. In doing this we are of course only measuring average strains over the region concerned. Also in view of the very small changes in dimensions, it is difficult to archive accuracy in the measurements

In practice, electrical strain gage provide a more accurate and convenient method of measuring strains.

A typical strain gage is shown below.

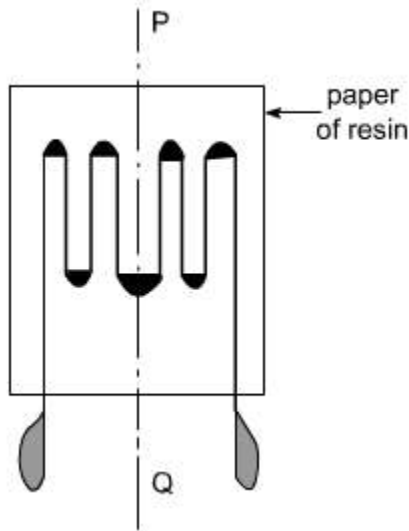

The gage shown above can measure normal strain in the local plane of the surface in the direction of line PQ, which is parallel to the folds of paper. This strain is an average value of for the region covered by the gage, rather than a value at any particular point.

The strain gage is not sensitive to normal strain in the direction perpendicular to PQ, nor does it respond to shear strain. therefore, in order to determine the state of strain at a particular small region of the surface, we usually need more than one strain gage.

To define a general two dimensional state of strain, we need to have three pieces of information, such as \hat{I}_x , \hat{I}_y and g_{xy} referred to any convenient orthogonal co-ordinates x and y in the plane of the surface. We therefore need to obtain measurements from three strain gages. These three gages must be arranged at different orientations on the surface to from a strain rosettt. Typical examples have been shown, where the gages are arranged at either 45° or 60° to each other as shown below :

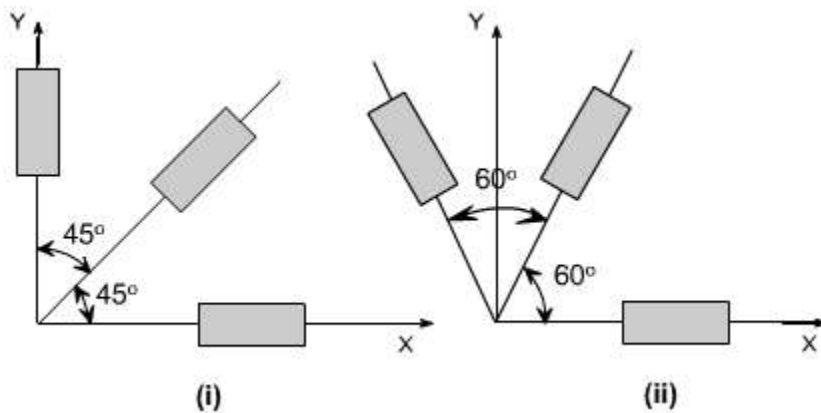

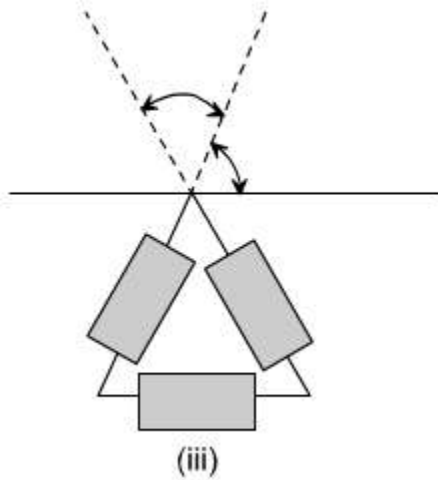

A group of three gages arranged in a particular fashion is called a strain rosette. Because the rosette is mounted on the surface of the body, where the material is in plane stress, therefore, the transformation equations for plane strain to calculate the strains in various directions.

Knowing the orientation of the three gages forming a rosette, together with the in – plane normal strains they record, the state of strain at the region of the surface concerned can be found. Let us consider the general case shown in the figure below, where three strain gages numbered 1, 2, 3, where three strain gages numbered 1, 2, 3 are arranged at an angles of θ_1 , θ_2 , θ_3 measured c.c.w from reference direction, which we take as x – axis.

Now, although the conditions at a surface, on which there are no shear or normal stress components. Are these of plane stress rather than the plane strain, we can still use strain transformation equations to express the three measured normal strains in terms of strain components \hat{I}_x , \hat{I}_y , \hat{I}_z and g_{xy} referred to x and y co-ordinates as

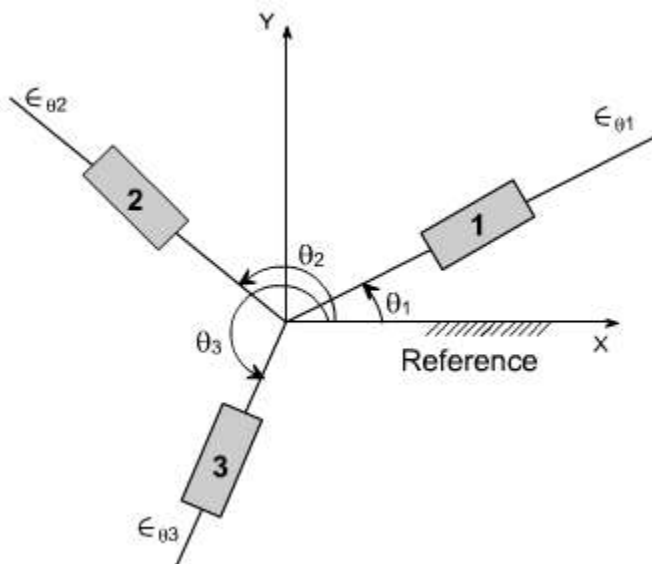

$$\begin{aligned}\epsilon_{\theta_1} &= \epsilon_x \cos^2 \theta_1 + \epsilon_y \sin^2 \theta_1 + \gamma_{xy} \sin \theta_1 \cdot \cos \theta_1 \\ \epsilon_{\theta_2} &= \epsilon_x \cos^2 \theta_2 + \epsilon_y \sin^2 \theta_2 + \gamma_{xy} \sin \theta_2 \cdot \cos \theta_2 \\ \epsilon_{\theta_3} &= \epsilon_x \cos^2 \theta_3 + \epsilon_y \sin^2 \theta_3 + \gamma_{xy} \sin \theta_3 \cdot \cos \theta_3\end{aligned}$$

This is a set of three simultaneous linear algebraic equations for the three unknowns $\hat{\epsilon}_x$, $\hat{\epsilon}_y$, γ_{xy} to solve these equations is a laborious one as far as manually is concerned, but with computer it can be readily done. Using these later on, the state of strain can be determined at any point.

Let us consider a 45° degree strain rosette consisting of three electrical – resistance strain gages arranged as shown in the figure below :

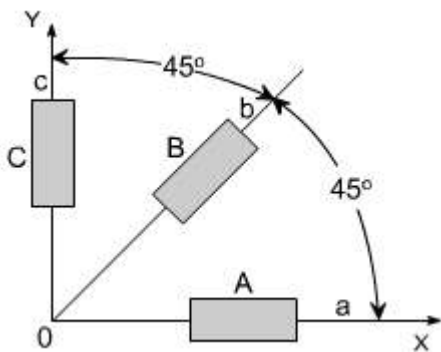

The gages A, B, C measure the normal strains $\hat{\epsilon}_a$, $\hat{\epsilon}_b$, $\hat{\epsilon}_c$ in the direction of lines OA, OB and OC.

Thus

$$\epsilon_{\theta_1} = \epsilon_x \cos^2 \theta_1 + \epsilon_y \sin^2 \theta_1 + \gamma_{xy} \sin \theta_1 \cdot \cos \theta_1$$

for $\theta_1 = 0; \epsilon_{\theta_1} = \epsilon_a$

$$\boxed{\epsilon_{\theta_1} = \epsilon_a} \quad (1)$$

again

$$\epsilon_{\theta_2} = \epsilon_x \cos^2 \theta_2 + \epsilon_y \sin^2 \theta_2 + \gamma_{xy} \sin \theta_2 \cdot \cos \theta_2$$

for gage B; $\theta_2 = 45^\circ$

$$\epsilon_{\theta_2} = \epsilon_b$$

$$\epsilon_b = \epsilon_x \cos^2 45^\circ + \epsilon_y \sin^2 45^\circ + \gamma_{xy} \sin 45^\circ \cdot \cos 45^\circ$$

$$\epsilon_b = \epsilon_x \frac{1}{2} + \epsilon_y \frac{1}{2} + \frac{1}{2} \gamma_{xy} = \frac{\epsilon_x + \epsilon_y + \gamma_{xy}}{2}$$

$$\gamma_{xy} = 2 \epsilon_b - (\epsilon_x + \epsilon_y)$$

since $\epsilon_x = \epsilon_a$

$$\boxed{\gamma_{xy} = 2 \epsilon_b - (\epsilon_a + \epsilon_y)} \quad (2)$$

for the gage C

$$\epsilon_{\theta_3} = \epsilon_x \cos^2 \theta_3 + \epsilon_y \sin^2 \theta_3 + \gamma_{xy} \sin \theta_3 \cdot \cos \theta_3$$

for $\theta_3 = 90^\circ; \epsilon_{\theta_3} = \epsilon_c$

or $\boxed{\epsilon_c = \epsilon_y} \quad (3)$

Thus, substituting the relation (3) in the equation (2) we get

$$g_{xy} = 2\hat{I}_b - (\hat{I}_a + \hat{I}_c) \text{ and other equation becomes } \hat{I}_x = \hat{I}_a ; \hat{I}_y = \hat{I}_c$$

Since the gages A and C are aligned with the x and y axes, they give the strains \hat{I}_x and \hat{I}_y directly

Thus, \hat{I}_x , \hat{I}_y and g_{xy} can easily be determined from the strain gage readings. Knowing these strains, we can calculate the strains in any other directions by means of Mohr's circle or from the transformation equations.

The 60° Rossett:

For the 60° strain rosette, using the same procedure we can obtain following relation.

$$\epsilon_x = \epsilon_a$$

$$\epsilon_y = \frac{1}{3}(2 \cdot \epsilon_b + 2 \cdot \epsilon_c - \epsilon_a)$$

$$\gamma_{xy} = \frac{2}{\sqrt{3}}(\epsilon_c - \epsilon_b)$$

LECTURE 9

STRESS - STRAIN RELATIONS

Stress – Strain Relations: The Hook's law, states that within the elastic limits the stress is proportional to the strain since for most materials it is impossible to describe the entire stress – strain curve with simple mathematical expression, in any given problem the behavior of the materials is represented by an idealized stress – strain curve, which emphasizes those aspects of the behaviors which are most important is that particular problem.

(i) Linear elastic material:

A linear elastic material is one in which the strain is proportional to stress as shown below:

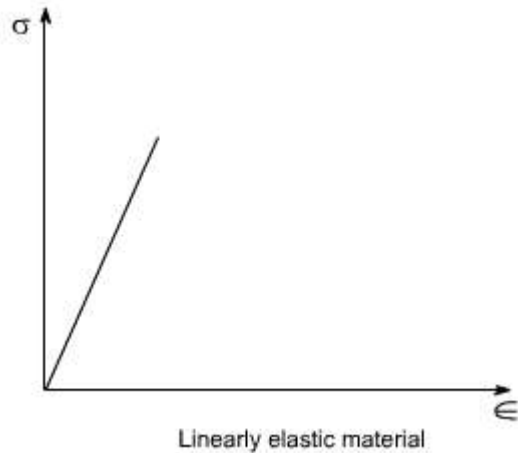

There are also other types of idealized models of material behavior.

(ii) Rigid Materials:

It is the one which donot experience any strain regardless of the applied stress.

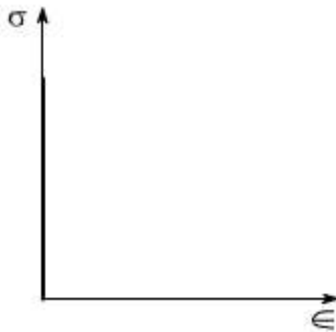

(iii) Perfectly plastic(non-strain hardening):

A perfectly plastic i.e non-strain hardening material is shown below:

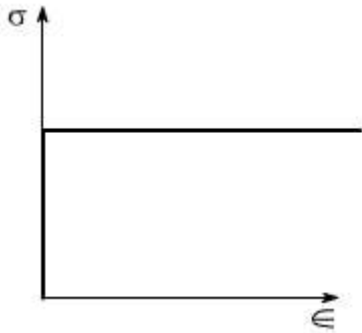

(iv) Rigid Plastic material(strain hardening):

A rigid plastic material i.e strain hardening is depicted in the figure below:

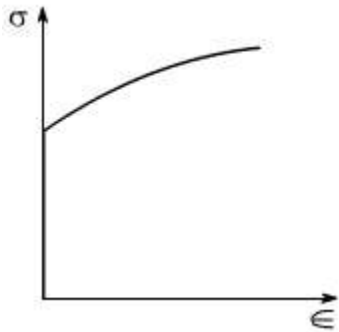

(v) Elastic Perfectly Plastic material:

The elastic perfectly plastic material is having the characteristics as shown below:

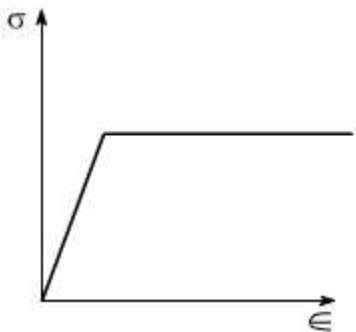

(vi) Elastic – Plastic material:

The elastic plastic material exhibits a stress Vs strain diagram as depicted in the figure below:

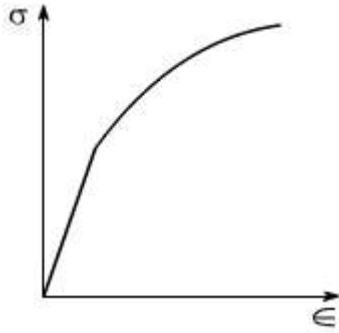

Elastic Stress – strain Relations :

Previously stress – strain relations were considered for the special case of a uniaxial loading i.e. only one component of stress i.e. the axial or normal component of stress was coming into picture. In this section we shall generalize the elastic behavior, so as to arrive at the relations which connect all the six components of stress with the six components of elastic stress. Further, we would restrict ourselves to linearly elastic material.

Before writing down the relations let us introduce a term ISOTROPY

ISOTROPIC: If the response of the material is independent of the orientation of the load axis of the sample, then we say that the material is isotropic or in other words we can say that isotropy of a material is a characteristic, which gives us the information that the properties are the same in the three orthogonal directions x y z, on the other hand if the response is dependent on orientation it is known as anisotropic.

Examples of anisotropic materials, whose properties are different in different directions are

- (i) Wood
- (ii) Fibre reinforced plastic
- (iii) Reinforced concrete

HOMOGENIUS: A material is homogenous if it has the same composition throughout its body. Hence the elastic properties are the same at every point in the body. However, the properties need not to be the same in all the directions for the material to be homogenous. Isotropic materials have the same elastic properties in all the directions. Therefore, the material must be both homogenous and isotropic in order to have the lateral strains to be the same at every point in a particular component.

Generalized Hook's Law: We know that for stresses not greater than the proportional limit.

$$\epsilon = \frac{\sigma}{E} \text{ or } \mu = - \frac{|\epsilon_{\text{lateral}}|}{|\epsilon_{\text{axial}}|}$$

These equation expresses the relationship between stress and strain (Hook's law) for uniaxial state of stress only when the stress is not greater than the proportional limit. In order to analyze the deformational effects produced by all the stresses, we shall consider the effects of one axial stress at a time. Since we presumably are dealing with strains of the order of one percent or less. These effects can be superimposed arbitrarily. The figure below shows the general triaxial state of stress.

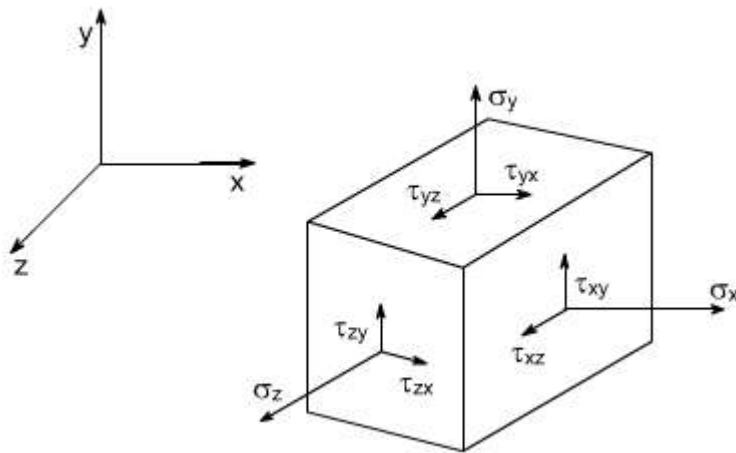

Let us consider a case when s_x alone is acting. It will cause an increase in dimension in X-direction whereas the dimensions in y and z direction will be decreased.

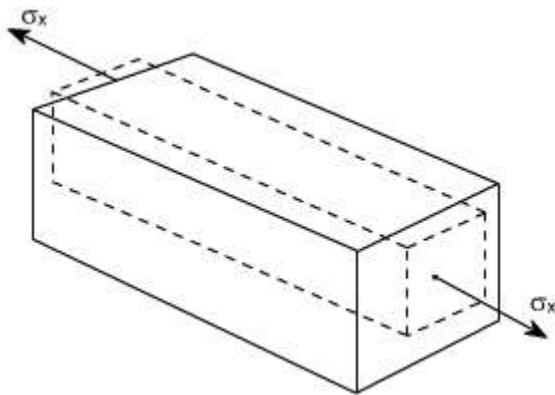

$$\epsilon_x = \frac{\sigma_x}{E}, \epsilon_y = -\mu \epsilon_x; \epsilon_z = -\mu \epsilon_x$$

$$\epsilon_x = \frac{\sigma_x}{E}; \epsilon_y = -\mu \frac{\sigma_x}{E}; \epsilon_z = -\mu \frac{\sigma_x}{E}$$

Therefore the resulting strains in three directions are

Similarly let us consider that normal stress s_y alone is acting and the resulting strains are

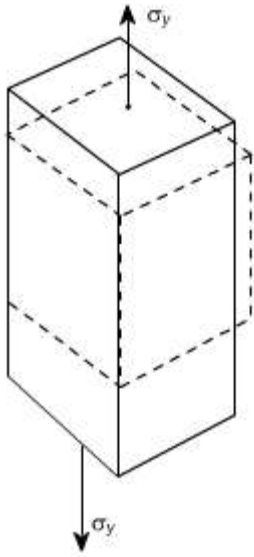

$$\epsilon_y = \frac{\sigma_y}{E}, \epsilon_x = -\mu \epsilon_y; \epsilon_z = -\mu \epsilon_y$$

$$\epsilon_y = \frac{\sigma_y}{E}; \epsilon_x = -\mu \frac{\sigma_y}{E}; \epsilon_z = -\mu \frac{\sigma_y}{E}$$

Now let us consider the stress σ_z acting alone, thus the strains produced are

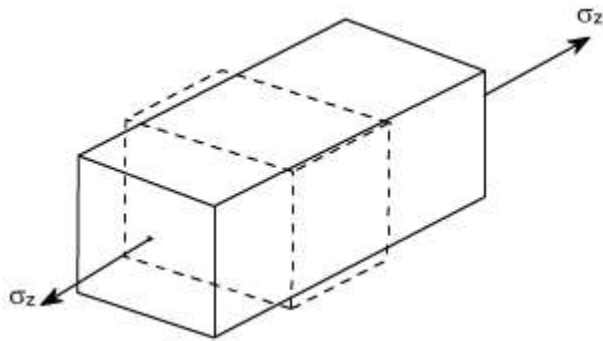

$$\epsilon_z = \frac{\sigma_z}{E}, \epsilon_y = -\mu \epsilon_z; \epsilon_x = -\mu \epsilon_z$$

$$\epsilon_z = \frac{\sigma_z}{E}; \epsilon_y = -\mu \frac{\sigma_z}{E}; \epsilon_x = -\mu \frac{\sigma_z}{E}$$

Thus the total strain in any one direction is

$$\epsilon_x = \frac{\sigma_x}{E} - \frac{\mu}{E}(\sigma_y + \sigma_z) \quad (1)$$

In a similar manner, the total strain in the y and z directions become

$$\epsilon_y = \frac{\sigma_y}{E} - \frac{\mu}{E}(\sigma_x + \sigma_z) \quad (2)$$

$$\epsilon_z = \frac{\sigma_z}{E} - \frac{\mu}{E}(\sigma_x + \sigma_y) \quad (3)$$

In the following analysis shear stresses were not considered. It can be shown that for an isotropic material's a shear stress will produce only its corresponding shear strain and will not influence the axial strain. Thus, we can write Hook's law for the individual shear

$$\gamma_{xy} = \frac{\tau_{xy}}{G} \quad (4)$$

$$\gamma_{yz} = \frac{\tau_{yz}}{G} \quad (5)$$

$$\gamma_{zx} = \frac{\tau_{zx}}{G} \quad (6)$$

strains and shear stresses in the following manner.

The Equations (1) through (6) are known as Generalized Hook's law and are the constitutive equations for the linear elastic isotropic materials. When these equations isotropic materials. When these equations are used as written, the strains can be completely determined from known values of the stresses. To engineers the plane stress situation is of much relevance (i.e. $s_z = t_{xz} = t_{yz} = 0$), Thus then the above set of equations reduces to

$$\epsilon_x = \frac{\sigma_x}{E} - \frac{\mu\sigma_y}{E}$$

$$\epsilon_y = \frac{\sigma_y}{E} - \frac{\mu\sigma_x}{E}$$

$$\epsilon_z = -\mu\frac{\sigma_x}{E} - \frac{\mu\sigma_y}{E} \text{ and } \tau_{xy} = \frac{\gamma_{xy}}{G}$$

Their inverse relations can be also determined and are given as

$$\sigma_x = \frac{E}{(1-\mu^2)} (\epsilon_x + \mu\epsilon_y)$$

$$\sigma_y = \frac{E}{(1-\mu^2)} (\epsilon_y + \mu\epsilon_x)$$

$$\tau_{xy} = G \cdot \gamma_{xy}$$

Hook's law is probably the most well known and widely used constitutive equations for an engineering materials.” However, we can not say that all the engineering materials are linear elastic isotropic ones. Because now in the present times, the new materials are being developed every day. Many useful materials exhibit nonlinear response and are not elastic too.

Plane Stress: In many instances the stress situation is less complicated for example if we pull one long thin wire of uniform section and examine – small parallelepiped where x – axis coincides with the axis of the wire

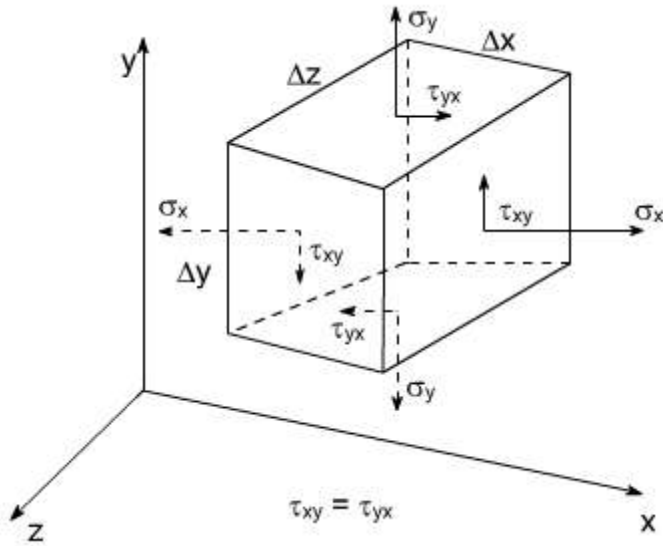

So if we take the xy plane then σ_x , σ_y , τ_{xy} will be the only stress components acting on the parallelepiped. This combination of stress components is called the plane stress situation

A plane stress may be defined as a stress condition in which all components associated with a given direction (i.e the z direction in this example) are zero

$$\sigma_z = \tau_{zx} = \tau_{zy} = 0$$

Plane strain: If we focus our attention on a body whose particles all lie in the same plane and which deforms only in this plane. This deforms only in this plane. This type of deformation is called as the plane strain, so for such a situation.

$\hat{I}_z = g_{zx} = g_{zy} = 0$ and the non – zero terms would be \hat{I}_x , \hat{I}_y & g_{xy}

i.e. if strain components \hat{I}_x , \hat{I}_y and g_{xy} and angle q are specified, the strain components \hat{I}_x' , \hat{I}_y' and g_{xy}' with respect to some other axes can be determined.

ELASTIC CONSTANTS

In considering the elastic behavior of an isotropic materials under, normal, shear and hydrostatic loading, we introduce a total of four elastic constants namely E , G , K , and g .

It turns out that not all of these are independent to the others. In fact, given any two of them, the other two can be found out . Let us define these elastic constants

- (i) E = Young's Modulus of Rigidity
= Stress / strain
- (ii) G = Shear Modulus or Modulus of rigidity

= Shear stress / Shear strain

(iii) g = Poisson's ratio

= - lateral strain / longitudinal strain

(iv) K = Bulk Modulus of elasticity

= Volumetric stress / Volumetric strain

Where

Volumetric strain = sum of linear strain in x, y and z direction.

Volumetric stress = stress which cause the change in volume.

Let us find the relations between them

LECTURE 10

RELATION AMONG ELASTIC CONSTANTS

Relation between E, G and ν :

Let us establish a relation among the elastic constants E, G and ν . Consider a cube of material of side 'a' subjected to the action of the shear and complementary shear stresses as shown in the figure and producing the strained shape as shown in the figure below.

Assuming that the strains are small and the angle A C B may be taken as 45° .

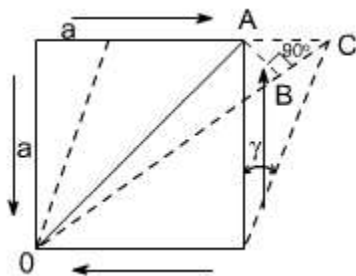

Therefore strain on the diagonal OA

= Change in length / original length

Since angle between OA and OB is very small hence OA @ OB therefore BC, is the change in the length of the diagonal OA

Thus, strain on diagonal $OA = \frac{BC}{OA}$

$$= \frac{AC \cos 45^\circ}{OA}$$

$$OA = \frac{a}{\sin 45^\circ} = a\sqrt{2}$$

hence strain = $\frac{AC}{a\sqrt{2}} \cdot \frac{1}{\sqrt{2}}$

$$= \frac{AC}{2a}$$

but $AC = a\gamma$

where $\gamma =$ shear strain

Thus, the strain on diagonal = $\frac{a\gamma}{2a} = \frac{\gamma}{2}$

From the definition

$$G = \frac{\tau}{\gamma} \text{ or } \gamma = \frac{\tau}{G}$$

thus, the strain on diagonal = $\frac{\gamma}{2} = \frac{\tau}{2G}$

Now this shear stress system is equivalent or can be replaced by a system of direct stresses at 45° as shown below. One set will be compressive, the other tensile, and both will be equal in value to the applied shear strain.

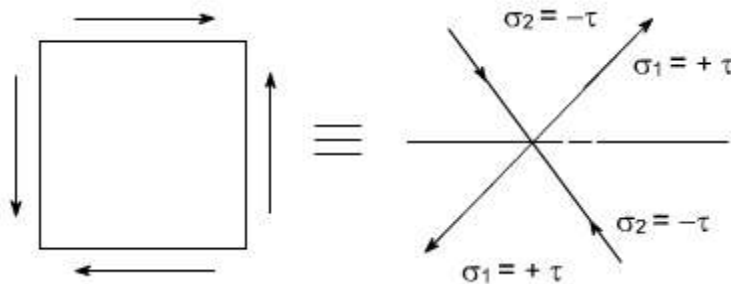

Thus, for the direct state of stress system which applies along the diagonals:

$$\begin{aligned} \text{strain on diagonal} &= \frac{\sigma_1}{E} - \mu \frac{\sigma_2}{E} \\ &= \frac{\tau}{E} - \mu \frac{(-\tau)}{E} \\ &= \frac{\tau}{E}(1 + \mu) \end{aligned}$$

equating the two strains one may get

$$\frac{\tau}{2G} = \frac{\tau}{E}(1 + \mu)$$

or $\boxed{E = 2G(1 + \mu)}$

We have introduced a total of four elastic constants, i.e E, G, K and g. It turns out that not all of these are independent of the others. Infact given any two of them, the other two can be found.

$$\text{Again } E = 3K(1 - 2\gamma)$$

$$\Rightarrow \frac{E}{3(1 - 2\gamma)} = K$$

$$\text{if } \gamma = 0.5 \quad K = \infty$$

$$\epsilon_v = \frac{(1 - 2\gamma)}{E} (\epsilon_x + \epsilon_y + \epsilon_z) = 3 \frac{\sigma}{E} (1 - 2\gamma)$$

(for $\epsilon_x = \epsilon_y = \epsilon_z$ hydrostatic state of stress)

$$\epsilon_v = 0 \text{ if } \gamma = 0.5$$

irrespective of the stresses i.e, the material is incompressible.

When $\gamma = 0.5$ Value of k is infinite, rather than a zero value of E and volumetric strain is zero, or in other words, the material is incompressible.

Relation between E, K and u :

Consider a cube subjected to three equal stresses s as shown in the figure below

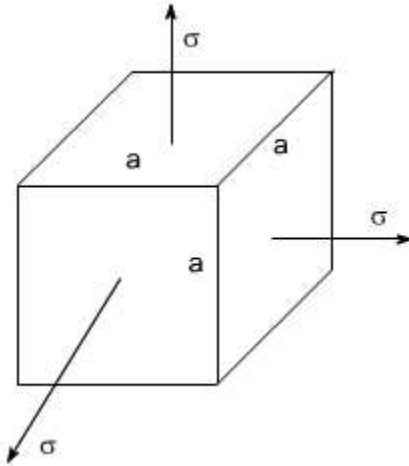

The total strain in one direction or along one edge due to the application of hydrostatic stress or volumetric stress s is given as

$$= \frac{\sigma}{E} - \gamma \frac{\sigma}{E} - \gamma \frac{\sigma}{E}$$

$$= \frac{\sigma}{E} (1 - 2\gamma)$$

volumetric strain = 3 . linear strain

$$\text{volumetric strain} = \epsilon_x + \epsilon_y + \epsilon_z$$

or thus, $\epsilon_x = \epsilon_y = \epsilon_z$

$$\text{volumetric strain} = 3 \frac{\sigma}{E} (1 - 2\gamma)$$

By definition

$$\text{Bulk Modulus of Elasticity (K)} = \frac{\text{Volumetric stress}(\sigma)}{\text{Volumetric strain}}$$

or

$$\text{Volumetric strain} = \frac{\sigma}{K}$$

Equating the two strains we get

$$\frac{\sigma}{K} = 3 \cdot \frac{\sigma}{E} (1 - 2\gamma)$$

$$\boxed{E = 3K(1 - 2\gamma)}$$

Relation between E, G and K :

The relationship between E, G and K can be easily determined by eliminating ν from the already derived relations

$$E = 2G(1 + \nu) \text{ and } E = 3K(1 - \nu)$$

Thus, the following relationship may be obtained

$$\boxed{E = \frac{9GK}{3K + G}}$$

Relation between E, K and ν :

From the already derived relations, ν can be eliminated

$$E = 2G(1 + \nu)$$

$$E = 3K(1 - 2\nu)$$

Thus, we get

$$3k(1 - 2\nu) = 2G(1 + \nu)$$

therefore

$$\nu = \frac{(3K - 2G)}{2(G + 3K)}$$

or

$$\boxed{\nu = 0.5(3K - 2G)(G + 3K)}$$

Engineering Brief about the elastic constants :

We have introduced a total of four elastic constants i.e E, G, K and ν . It may be seen that not all of these are independent of the others. Infact given any two of them, the other two can be determined. Futher, it may be noted that

$$E = 3K(1 - 2\nu)$$

or

$$K = \frac{E}{(1 - 2\nu)}$$

if $\nu = 0.5$; $K = \infty$

$$\text{Also } \epsilon_v = \frac{(1 - 2\nu)}{E} (\sigma_x + \sigma_y + \sigma_z)$$

$$= \frac{(1 - 2\nu)}{E} \cdot 3\sigma \quad (\text{for hydrostatic state of stress i.e } \sigma_x = \sigma_y = \sigma_z = \sigma)$$

hence if $\nu = 0.5$, the value of K becomes infinite, rather than a zero value of E and the volumetric strain is zero or in otherwords, the material becomes incompressible

Futher, it may be noted that under condition of simple tension and simple shear, all real materials tend to experience displacements in the directions of the applied forces and Under hydrostatic loading they tend to increase in volume. In otherwords the value of the elastic constants E, G and K cannot be negative

Therefore, the relations

$$E = 2 G (1 + \nu)$$

$$E = 3 K (1 - \nu)$$

Yields $\boxed{-1 \leq \nu \leq 0.5}$

In actual practice no real material has value of Poisson's ratio negative . Thus, the value of ν cannot be greater than 0.5, if however $\nu > 0.5$ than $\hat{I}_v = -ve$, which is physically

unlikely because when the material is stretched its volume would always increase.

Determination of Poisson's ratio: Poisson's ratio can be determined easily by simultaneous use of two strain gauges on a test specimen subjected to uniaxial tensile or compressive load. One gage is mounted parallel to the longitudinal axis of the specimen and other is mounted perpendicular to the longitudinal axis as shown below:

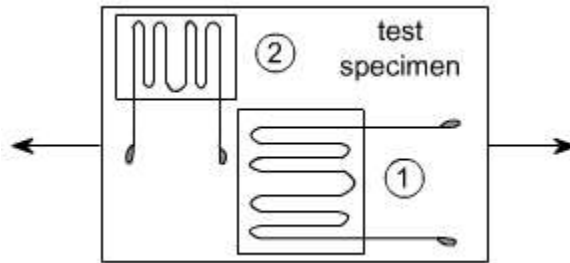

LECTURE 11

MECHANICAL PROPERTIES

Mechanical Properties:

In the course of operation or use, all the articles and structures are subjected to the action of external forces, which create stresses that inevitably cause deformation. To keep these stresses, and, consequently deformation within permissible limits it is necessary to select suitable materials for the Components of various designs and to apply the most effective heat treatment. i.e. a Comprehensive knowledge of the chief characteristics of the semi-finished metal products & finished metal articles (such as strength, ductility, toughness etc) are essential for the purpose.

For this reason the specification of metals, used in the manufacture of various products and structure, are based on the results of mechanical tests or we say that the mechanical tests conducted on the specially prepared specimens (test pieces) of standard form and size on special machines to obtained the strength, ductility and toughness characteristics of the metal.

The conditions under which the mechanical test are conducted are of three types

(1) **Static:** When the load is increased slowly and gradually and the metal is loaded by tension, compression, torsion or bending.

(2) **Dynamic:** when the load increases rapidly as in impact

(3) **Repeated or Fatigue:** (both static and impact type) . i.e. when the load repeatedly varies in the course of test either in value or both in value and direction Now let us

consider the uniaxial tension test.

[For application where a force comes on and off the structure a number of times, the material cannot withstand the ultimate stress of a static tool. In such cases the ultimate strength depends on no. of times the force is applied as the material works at a particular stress level. Experiments one conducted to compute the number of cycles requires to break to specimen at a particular stress when fatigue or fluctuating load is acting. Such tests are known as fatigue tests]

Uniaxial Tension Test: This test is of static type i.e. the load is increased comparatively slowly from zero to a certain value.

Standard specimen's are used for the tension test.

There are two types of standard specimen's which are generally used for this purpose, which have been shown below:

Specimen I:

This specimen utilizes a circular X-section.

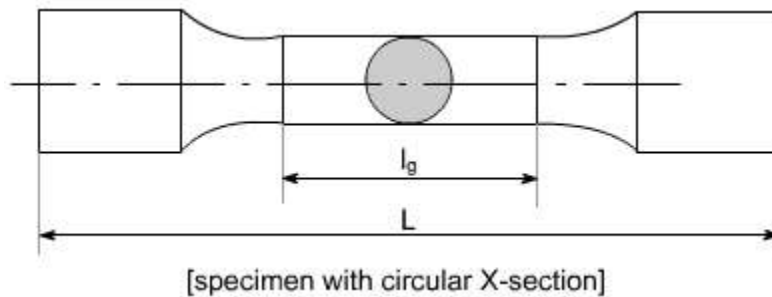

Specimen II:

This specimen utilizes a rectangular X-section.

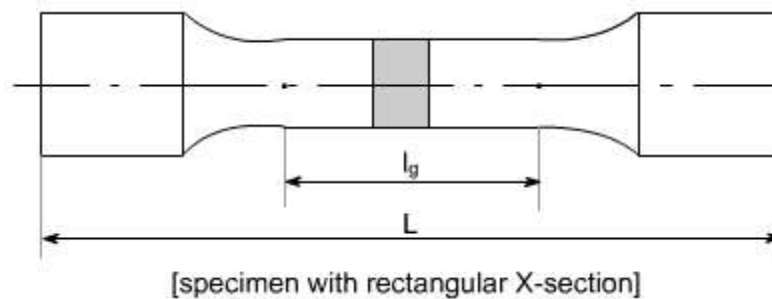

l_g = gauge length i.e. length of the specimen on which we want to determine the mechanical properties. The uniaxial tension test is carried out on tensile testing machine and the following steps are performed to conduct this test.

- (i) The ends of the specimen's are secured in the grips of the testing machine.
- (ii) There is a unit for applying a load to the specimen with a hydraulic or mechanical drive.
- (iii) There must be a some recording device by which you should be able to measure the final output in the form of Load or stress. So the testing machines are often equipped with the pendulum type lever, pressure gauge and hydraulic capsule and the stress Vs strain diagram is plotted which has the following shape.

A typical tensile test curve for the mild steel has been shown below

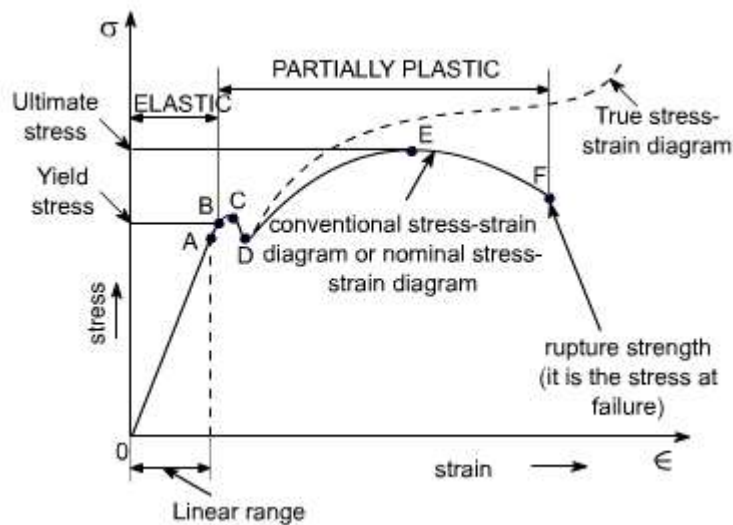

Nominal stress – Strain OR Conventional Stress – Strain diagrams:

Stresses are usually computed on the basis of the original area of the specimen; such stresses are often referred to as conventional or nominal stresses.

True stress – Strain Diagram:

Since when a material is subjected to a uniaxial load, some contraction or expansion always takes place. Thus, dividing the applied force by the corresponding actual area of the specimen at the same instant gives the so called true stress.

SALIENT POINTS OF THE GRAPH:

(A) So it is evident from the graph that the strain is proportional to strain or elongation is proportional to the load giving a st.line relationship. This law of proportionality is valid upto a point A.

or we can say that point A is some ultimate point when the linear nature of the graph ceases or there is a deviation from the linear nature. This point is known as **the limit of**

proportionality or the proportionality limit.

(B) For a short period beyond the point A, the material may still be elastic in the sense that the deformations are completely recovered when the load is removed. The limiting point B is termed as **Elastic Limit**.

(C) and (D) - Beyond the elastic limit plastic deformation occurs and strains are not totally recoverable. There will be thus permanent deformation or permanent set when load is removed. These two points are termed as upper and lower yield points respectively. The stress at the yield point is called the yield strength.

A study a stress – strain diagrams shows that the yield point is so near the proportional limit that for most purpose the two may be taken as one. However, it is much easier to locate the former. For material which do not posses a well define yield points, In order to find the yield point or yield strength, an offset method is applied.

In this method a line is drawn parallel to the straight line portion of initial stress diagram by off setting this by an amount equal to 0.2% of the strain as shown as below and this happens especially for the low carbon steel.

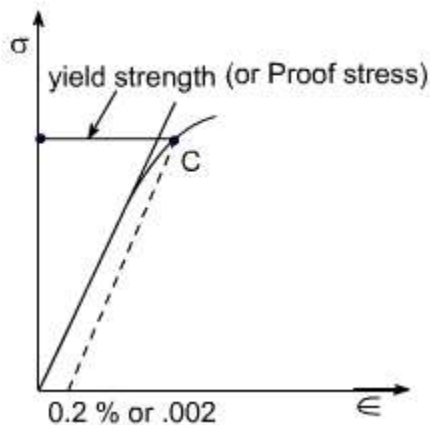

(E) A further increase in the load will cause marked deformation in the whole volume of the metal. The maximum load which the specimen can with stand without failure is called the load at the ultimate strength.

The highest point 'E' of the diagram corresponds to the ultimate strength of a material.

s_u = Stress which the specimen can with stand without failure & is known as Ultimate Strength or Tensile Strength.

s_u is equal to load at E divided by the original cross-sectional area of the bar.

(F) Beyond point E, the bar begins to forms neck. The load falling from the maximum until fracture occurs at F.

[Beyond point E, the cross-sectional area of the specimen begins to reduce rapidly over a relatively small length of bar and the bar is said to form a neck. This necking takes place whilst the load reduces, and fracture of the bar finally occurs at point F]

Note: Owing to large reduction in area produced by the necking process the actual stress at fracture is often greater than the above value. Since the designers are interested in maximum loads which can be carried by the complete cross section, hence the stress at fracture is seldom of any practical value.

Percentage Elongation: ' d ':

The ductility of a material in tension can be characterized by its elongation and by the reduction in area at the cross section where fracture occurs.

It is the ratio of the extension in length of the specimen after fracture to its initial gauge length, expressed in percent.

$$\delta = \frac{(l_1 - l_g)}{l_g} \times 100$$

l_1 = gauge length of specimen after fracture(or the distance between the gage marks at fracture)

l_g = gauge length before fracture(i.e. initial gauge length)

For 50 mm gauge length, steel may have a % elongation of the order of 10% to 40%.

Elastic Action:

The elastic is an adjective meaning capable of recovering size and shape after deformation. Elastic range is the range of stress below the elastic limit.

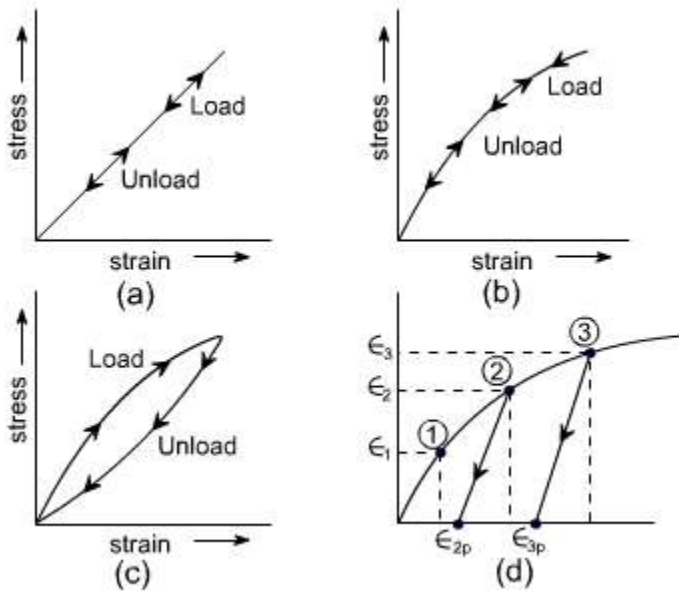

Many engineering materials behave as indicated in Fig(a) however, some behaves as shown in figures in (b) and (c) while in elastic range. When a material behaves as in (c), the σ vs ϵ is not single valued since the strain corresponding to any particular ' σ ' will depend upon loading history.

Fig (d): It illustrates the idea of elastic and plastic strain. If a material is stressed to level (1) and then released the strain will return to zero beyond this plastic deformation remains.

If a material is stressed to level (2) and then released, the material will recover the amount $(\epsilon_2 - \epsilon_{2p})$, where ϵ_{2p} is the plastic strain remaining after the load is removed. Similarly for level (3) the plastic strain will be ϵ_{3p} .

Ductile and Brittle Materials:

Based on this behaviour, the materials may be classified as ductile or brittle materials

Ductile Materials:

If we just examine the earlier tension curve one can notice that the extension of the materials over the plastic range is considerably in excess of that associated with elastic loading. The Capacity of materials to allow these large deformations or large extensions without failure is termed as ductility. The materials with high ductility are termed as ductile materials.

Brittle Materials:

A brittle material is one which exhibits a relatively small extensions or deformations to fracture, so that the partially plastic region of the tensile test graph is much reduced.

This type of graph is shown by the cast iron or steels with high carbon contents or concrete.

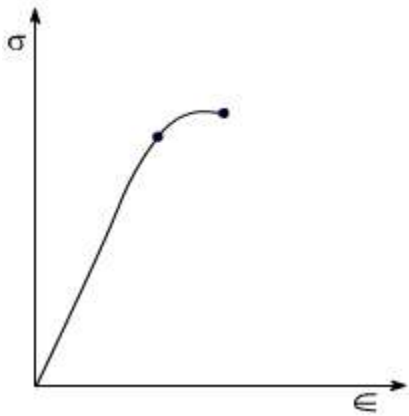

Conditions Affecting Mechanical Properties:

The Mechanical properties depend on the test conditions

- (1) It has been established that lowering the temperature or increasing the rate of deformation considerably increases the resistance to plastic deformation. Thus, at low temperature (or higher rates of deformation), metals and alloys, which are ductile at normal room temperature may fail with brittle fracture.
- (2) Notches i.e. sharp changes in cross sections have a great effect on the mechanical properties of the metals. A Notch will cause a non – uniform distribution of stresses. They will always contribute lowering the ductility of the materials. A notch reduces the ultimate strength of the high strength materials. Because of the non – uniform distribution of the stress or due to stress concentration.
- (3) Grain Size : The grain size also affects the mechanical properties.

Hardness:

Hardness is the resistance of a metal to the penetration of another harder body which does not receive a permanent set.

Hardness Tests consists in measuring the resistance to plastic deformation of layers of metals near the surface of the specimen i.e. there are Ball indentation Tests.

Ball indentation Tests:

This method consists in pressing a hardened steel ball under a constant load P into a specially prepared flat surface on the test specimen as indicated in the figures below :

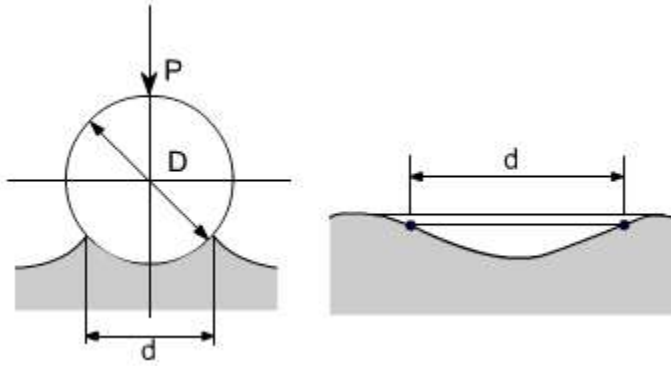

After removing the load an indentation remains on the surface of the test specimen. If area of the spherical surface in the indentation is denoted as F sq. mm. Brinell Hardness number is defined as :

$$Bhn = P / F$$

F is expressed in terms of D and d

D = ball diameter

d = diametric of indentation and Brinell Hardness number is given by

$$Bhn = \frac{2P}{\pi D (D - \sqrt{D^2 - d^2})}$$

Then is there is also **Vicker's Hardness Number** in which the ball is of conical shape.

IMPACT STRENGTH

Static tension tests of the unnotched specimen's do not always reveal the susceptibility of metal to brittle fracture. This important factor is determined in impact tests. In impact tests we use the notched specimen's



this specimen is placed on its supports on anvil so that blow of the striker is opposite to the notch the impact strength is defined as the energy A, required to rupture the specimen,

$$\text{Impact Strength} = A / f$$

Where f = It is the cross – section area of the specimen in cm² at fracture & obviously at notch.

The impact strength is a complex characteristic which takes into account both toughness

and strength of a material. The main purpose of notched – bar tests is to study the simultaneous effect of stress concentration and high velocity load application

Impact test are of the severest type and facilitate brittle fracture. Impact strength values can not be as yet be used for design calculations but these tests as rule provided for in specifications for carbon & alloy steels. Futher, it may be noted that in impact tests fracture may be either brittle or ductile. In the case of brittle fracture, fracture occurs by separation and is not accompanied by noticeable plastic deformation as occurs in the case of ductile fracture.

LECTURE 12

Compression Test: Machines used for compression testing are basically similar to those used for tensile testing often the same machine can be used to perform both tests.

Shape of the specimen: The shape of the machine to be used for the different materials are as follows:

- (i) **For metals and certain plastics:** The specimen may be in the from of a cylinder
- (ii) **For building materials:** Such as concrete or stone the shape of the specimen may be in the from of a cube.

Shape of stress stain diagram

(a) **Ductile materials:** For ductile material such as mild steel, the load Vs compression diagram would be as follows

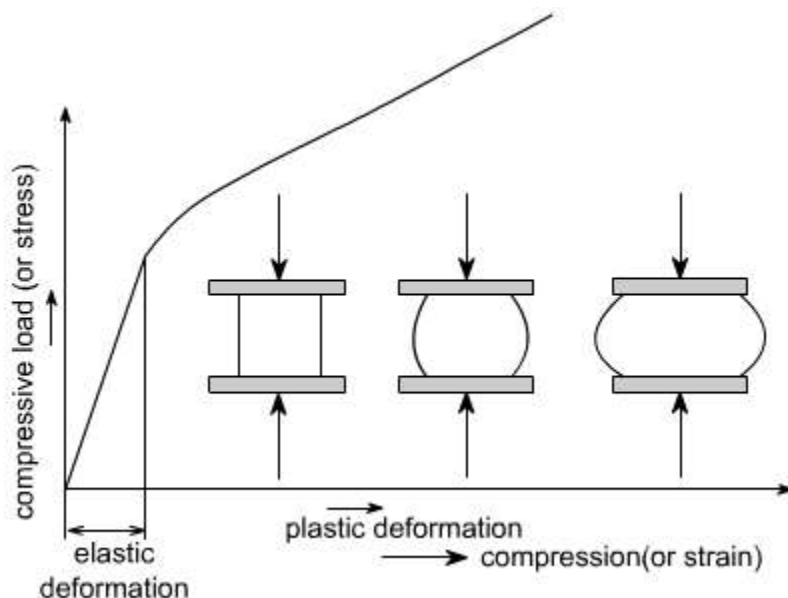

(1) The ductile materials such as steel, Aluminum, and copper have stress – strain diagrams similar to ones which we have for tensile test, there would be an elastic range which is then followed by a plastic region.

(2) The ductile materials (steel, Aluminum, copper) proportional limits in compression test are very much close to those in tension.

(3) In tension test, a specimen is being stretched, necking may occur, and ultimately fracture takes place. On the other hand when a small specimen of the ductile material is compressed, it begins to bulge on sides and becomes barrel shaped as shown in the figure above. With increasing load, the specimen is flattened out, thus offering increased resistance to further shortening (which means that the stress – strains curve goes upward) this effect is indicated in the diagram.

Brittle materials (in compression test)

Brittle materials in compression typically have an initial linear region followed by a region in which the shortening increases at a higher rate than does the load. Thus, the compression stress – strain diagram has a shape that is similar to the shape of the tensile diagram.

However, brittle materials usually reach much higher ultimate stresses in compression than in tension.

For cast iron, the shape may be like this

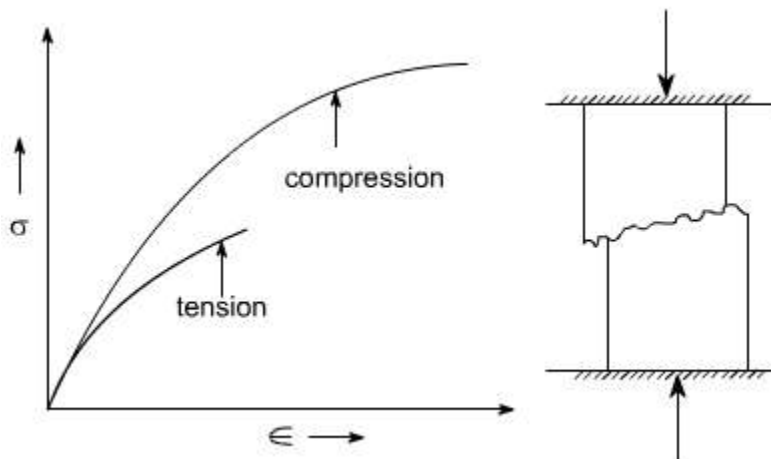

Brittle materials in compression behave elastically up to certain load, and then fail suddenly by splitting or by cracking in the way as shown in figure. The brittle fracture is performed by separation and is not accompanied by noticeable plastic deformation.

Hardness Testing:

The term 'hardness' is one having a variety of meanings; a hard material is

thought of as one whose surface resists indentation or scratching, and which has the ability to indent or cut other materials.

Hardness test: The hardness test is a comparative test and has been evolved mainly from the need to have some convenient method of measuring the resistance of materials to scratching, wear or in dentation this is also used to give a guide to overall strength of a materials, after as an inspection procedure, and has the advantage of being a non – destructive test, in that only small indentations are left permanently on the surface of the specimen.

Four hardness tests are customarily used in industry namely

- (i) Brinell
- (ii) Vickers
- (iii) Rockwell
- (vi) Shore Scleroscopy

The most widely used are the first two.

In the Brinell test the indenter is a hardened steel ball which is pressed into the surface using a known standard load. The diameter of resulting indentation is then measured using a microscope & scale.

Units:

The units of Brinell Hardness number in S.I Unit would have been N/mm^2 or Mpa

To avoid the confusion which would have been caused of her wise Hardness numbers are quotes as kgf / mm^2

Brinell Hardness test:

In the Brinell hardness test, a hardened steel ball is pressed into the flat surface of a test piece using a specified force. The ball is then removed and the diameter of the resulting indentation is measured using a microscope.

The Brinell Hardness no. (BHN) is defined as

$$BHN = P / A$$

Where P = Force applied to the ball.

A = curved area of the indentation

It may be shown that
$$A = \frac{1}{2} \pi D \left[D - \sqrt{D^2 - d^2} \right]$$

D = diameter of the ball,

d = the diameter of the indentation.

In the Brinell Test, the ball diameter and applied load are constant and are selected to suit the composition of the metal, its hardness, and selected to suit the composition of the metal, its hardness, the thickness etc. Further, the hardness of the ball should be at least 1.7 times than the test specimen to prevent permanent set in the ball.

Disadvantage of Brinell Hardness Test: The main disadvantage of the Brinell Hardness test is that the Brinell hardness number is not independent of the applied load. This can be realized from. Considering the geometry of indentations for increasing loads. As the ball is pressed into the surface under increasing load the geometry of the indentation changes.

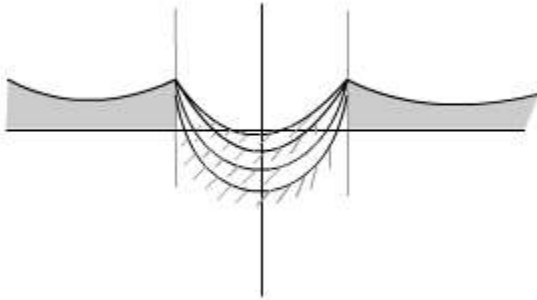

Here what we mean is that the geometry of the impression should not change w.r.t. load, however the size of impression may change.

Vickers Hardness test:

The Vicker's Hardness test follows a procedure exactly identical with that of Brinell test, but uses a different indenter. The steel ball is replaced by a diamond, having the form of a square – based pyramid with an angle of 136° between opposite faces. This is pressed into the flat surface of the test piece using a specified force, and the diagonals of the resulting indentation measured using a microscope. The Hardness, expressed as a Vicker's pyramid number is defined as the ratio F/A , where F is the force applied to the diamond and A is the surface area of the indentation.

$$A = \frac{\frac{1}{2}l^2}{\sin \frac{1}{2}(136^\circ)}$$

$$= \frac{l^2}{.854v_x} \Rightarrow H_V = \frac{F}{\frac{l^2}{.854}}$$

$$H_V = \frac{.854F}{l^2}$$

It may be shown that where l is the average length of the diagonal is $l = \frac{1}{2}(l_1 + l_2)$

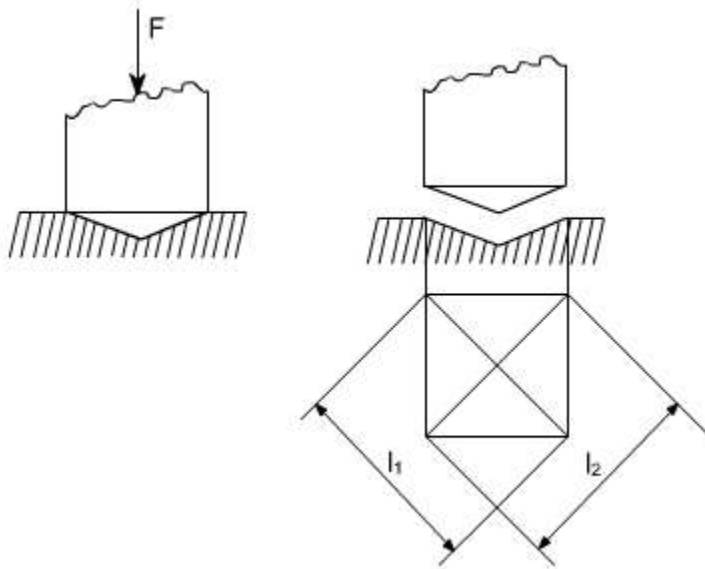

In the Vicker Test the indenters of pyramidal or conical shape are used & this overcomes the disadvantage which is faced in Brinell test i.e. as the load increases, the geometry of the indentation's does not change

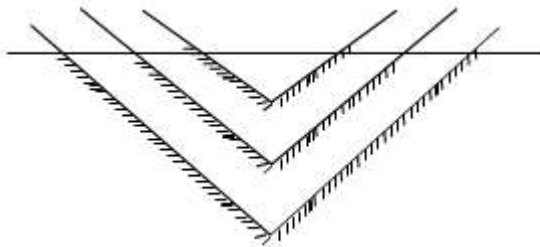

The Variation of Hardness number with load is given below.

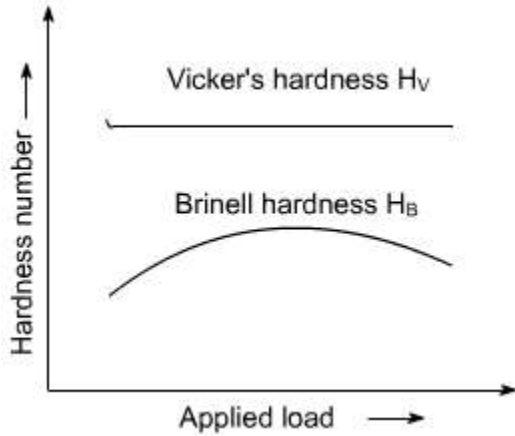

Advantage: Apart from the convenience the vicker's test has certain advantages over the Brinell test.

(i) Harder material can be tested and indentation can be smaller & therefore less obtrusive or damaging.

Upto a 300 kgf/mm^2 both tests give the same hardness number but above too the Brinell test is unreliable.

Rockwell Hardness Test :

The Rockwell Hardness test also uses an indenter when is pressed into the flat surface of the test piece, but differs from the Brinell and Vicker's test in that the measurement of hardness is based on the depth of penetration, not on the surface area of indentation. The indenter may be a conical diamond of 120° included angle, with a rounded apex. It is brought into contact with the test piece, and a force F is applied.

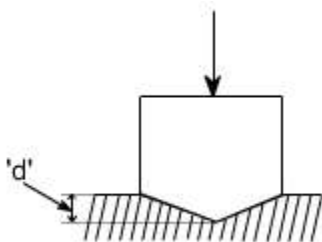

Advantages :

Rockwell tests are widely applied in industry due to rapidity and simplicity with which they may be performed, high accuracy, and due to the small size of the impressions produced on the surface.

Impact testing:

In an 'impact test' a notched bar of material, arranged either as a cantilever or as a simply

supported beam, is broken by a single blow in such a way that the total energy required to fracture it may be determined.

The energy required to fracture a material is of importance in cases of “shock loading” when a component or structure may be required to absorb the K.E of a moving object.

Often a structure must be capable of receiving an accidental ‘shock load’ without failing completely, and whether it can do this will be determined not by its strength but by its ability to absorb energy. A combination of strength and ductility will be required, since large amounts of energy can only be absorbed by large amounts of plastic deformation. The ability of a material to absorb a large amount of energy before breaking is often referred as toughness, and the energy absorbed in an impact test is an obvious indication of this property.

Impact tests are carried out on notched specimens, and the notches must not be regarded simply as a local reduction in the cross – sectional area of the specimen, Notches – and , in fact, surface irregularities of many kind – give rise to high local stresses, and are in practice, a potential source of cracks.

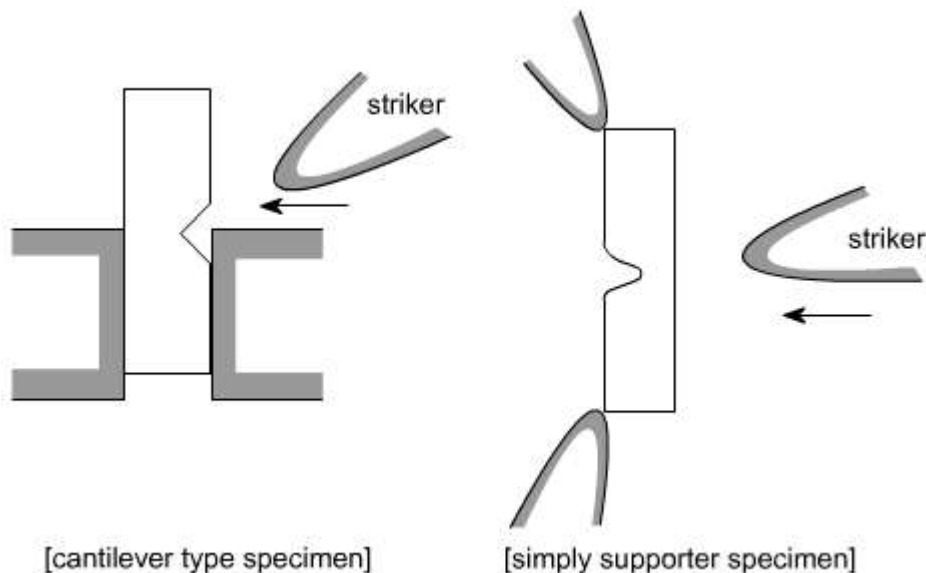

The specimen may be of circular or square cross – section arranged either as a cantilever or a simply supported beam.

Toughness: It is defined as the ability of the material to withstand crack i.e to prevent the transfer or propagation of cracks across its section hence causing failures. Cracks are propagated due to stress concentration.

Creep: Creep is the gradual increase of plastic strain in a material with time at constant load. Particularly at elevated temperatures some materials are susceptible to this phenomena and even under the constant load, mentioned strains can increase continually until fractures. This form of failure is particularly relevant to the turbines blades, nuclear

reactors, furnaces rocket motors etc.

The general form of strain versus time graph or creep curve is shown below.

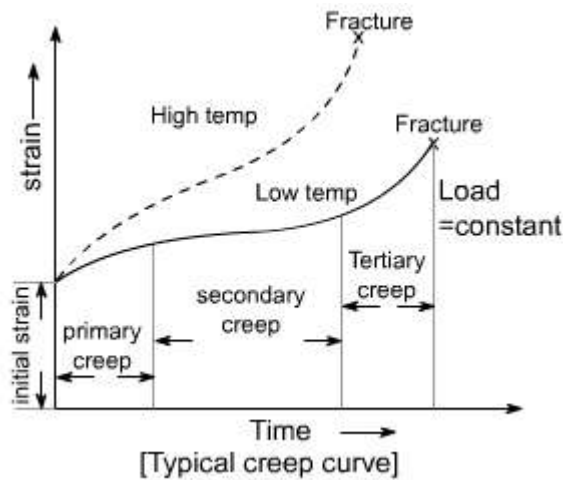

The general form of $\hat{\epsilon}$ Vs t graph or creep curve is shown below for two typical operation conditions, In each case the curve can be considered to exhibit four principal features

- An initial strain, due to the initial application of load. In most cases this would be an elastic strain.
- A primary creep region, during which the creep rate (slope of the graph) decreases.
- A secondary creep region, when the creep rate is sensibly constant.
- A tertiary creep region, during which the creep rate accelerates to final fracture.

It is obvious that a material which is susceptible to creep effects should only be subjected to stresses which keep it in secondary (st.line) region throughout its service life. This enables the amount of creep extension to be estimated and allowed for in design.

Practice Problems:

PROB 1: A standard mild steel tensile test specimen has a diameter of 16 mm and a gauge length of 80 mm such a specimen was tested to destruction, and the following results obtained.

Load at yield point = 87 kN

Extension at yield point = 173×10^{-6} m

Ultimate load = 124 kN

Total extension at fracture = 24 mm

Diameter of specimen at fracture = 9.8 mm

Cross - sectional area at fracture = 75.4 mm²

Cross - sectional Area 'A' = 200 mm²

Compute the followings:

- (i) Modulus of elasticity of steel
- (ii) The ultimate tensile stream
- (iii) The yield stress
- (iv) The percentage elongation
- (v) The Percentage reduction in Area.

PROB 2:

A light alloy specimen has a diameter of 16mm and a gauge Length of 80 mm. When tested in tension, the load extension graph proved linear up to a load of 6kN, at which point the extension was 0.034 mm. Determine the limits of proportionality stress and the modulus of elasticity of material.

Note: For a 16mm diameter specimen, the Cross – sectional area A = 200 mm²

This is according to tables Determine the limit of proportion try stream & the modulus of elasticity for the material.

Ans: 30 MN /m² , 70.5 GN /m²

solution:

$$\begin{aligned}\text{Limit of proportionaly stress} &= \frac{6 \text{ kN}}{200 \times 10^{-6}} \\ &= 30 \text{ MN/m}^2\end{aligned}$$

$$\begin{aligned}\text{Young Modulus} \quad E &= \frac{\text{Stress}}{\text{Strain}} \\ \text{strain} &= \frac{.034}{80} \\ E &= 30 \times 10^6 \div \frac{.034}{80} \\ &= 70.5 \text{ GN/m}^2\end{aligned}$$

LECTURE 13

Members Subjected to Uniaxial Stress

Members in Uni – axial state of stress

Introduction: [For members subjected to uniaxial state of stress]

For a prismatic bar loaded in tension by an axial force P, the elongation of the bar can be determined as

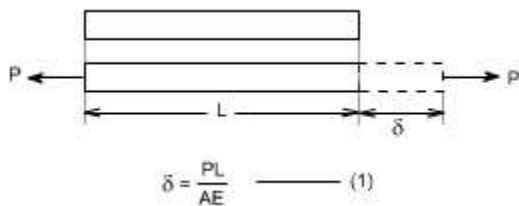

Suppose the bar is loaded at one or more intermediate positions, then equation (1) can be readily adapted to handle this situation, i.e. we can determine the axial force in each part of the bar i.e. parts AB, BC, CD, and calculate the elongation or shortening of each part separately, finally, these changes in lengths can be added algebraically to obtain the total change in length of the entire bar.

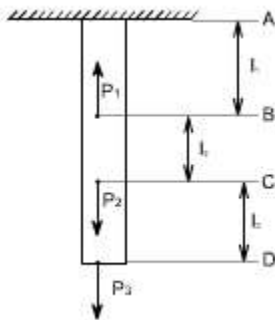

When either the axial force or the cross – sectional area varies continuously along the axis of the bar, then equation (1) is no longer suitable. Instead, the elongation can be found by considering a differential element of a bar and then the equation (1) becomes

$$d\delta = \frac{P_x dx}{E.A_x}$$
$$\delta = \int_0^l \frac{P_x dx}{E.A_x}$$

i.e. the axial force P_x and area of the cross – section A_x must be expressed as functions of x . If the expressions for P_x and A_x are not too complicated, the integral can be evaluated analytically, otherwise Numerical methods or techniques can be used to evaluate these

integrals.

stresses in Non – Uniform bars

Consider a bar of varying cross section subjected to a tensile force P as shown below.

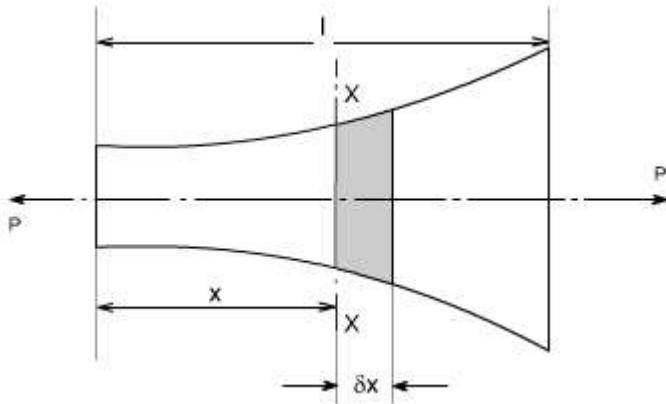

Let

a = cross sectional area of the bar at a chosen section XX

then

Stress $s = p / a$

If E = Young's modulus of bar then the strain at the section XX can be calculated

$$\hat{\epsilon} = s / E$$

Then the extension of the short element $d x. = \hat{\epsilon} \cdot \text{original length} = s / E. d^x$

$$= \frac{P}{E} \frac{\delta x}{a}$$

Thus, the extension for the entire bar is

$$\delta = \int_0^l \frac{P}{E} \frac{\delta x}{a}$$

$$\text{or total extension} = \frac{P}{E} \int_0^l \frac{\delta x}{a}$$

Now let us for example take a case when the bar tapers uniformly from d at $x = 0$ to D at $x = l$

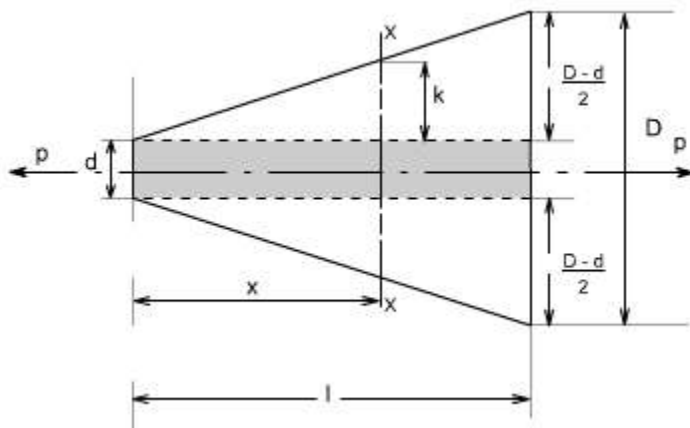
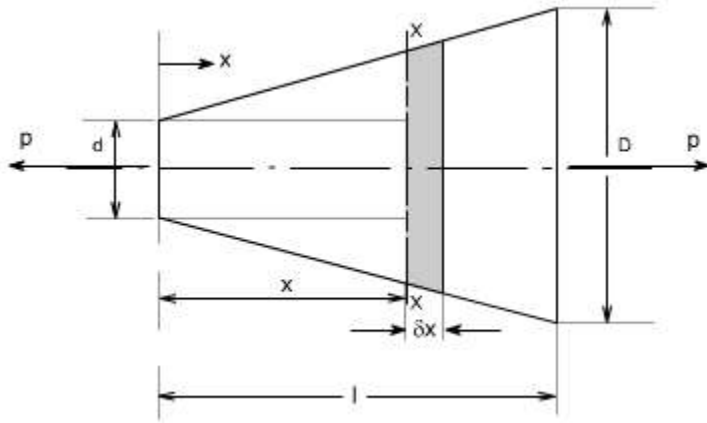

In order to compute the value of diameter of a bar at a chosen location let us determine the value of dimension k, from similar triangles

$$\frac{(D - d)/2}{l} = \frac{k}{x}$$

Thus, $k = \frac{(D - d)x}{2l}$

therefore, the diameter 'y' at the X-section is

$$\text{or } y = d + 2k$$

$$y = d + \frac{(D - d)x}{l}$$

Hence the cross-section area at section X- X will be

$$A_x \text{ or } a = \frac{\pi}{4} y^2$$

$$= \frac{\pi}{4} \left[d + (D - d) \frac{x}{l} \right]^2$$

hence the total extension of the bar will be given by expression

$$= \frac{P}{E} \int_0^l \frac{\delta x}{a}$$

substituting the value of 'a' to get the total extension of the bar

$$= \frac{\pi P}{4E} \int_0^l \frac{\delta x}{\left[d + (D - d) \frac{x}{l} \right]^2}$$

after carrying out the integration we get

$$= -\frac{4.P.l}{\pi E} \left[\frac{1}{D} - \frac{1}{d} \right]$$

$$= \frac{4.P.l}{\pi E D.d}$$

hence the total strain in the bar = $\frac{4.P.l}{\pi E D.d}$

An interesting problem is to determine the shape of a bar which would have a uniform stress in it under the action of its own weight and a load P.

let us consider such a bar as shown in the figure below:

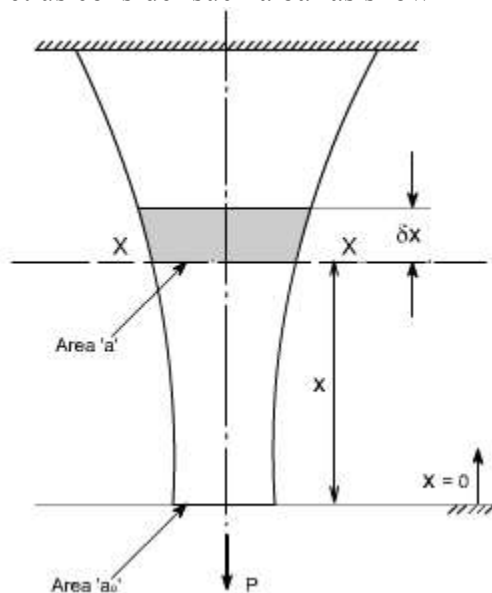

The weight of the bar being supported under section XX is

$$= \int_0^x \rho g a dx$$

where ρ is density of the bar.

thus the stress at XX is

$$\sigma = \frac{P + \int_0^x \rho g a dx}{a}$$

$$\text{or } \sigma \cdot a = P + \int_0^x \rho \cdot g \cdot a dx$$

Differentiating the above equation with respect to x we get

$$\sigma \cdot \frac{da}{dx} = \rho \cdot g \cdot a$$

$$\frac{da}{a} = \frac{\rho \cdot g}{\sigma} dx$$

integrating the above equation we get

$$\int \frac{da}{a} = \int \frac{\rho \cdot g}{\sigma} dx$$

$$\log_e a = \frac{\rho \cdot g \cdot x}{\sigma} + \text{constant}$$

In order to determine the constant of integration

let us apply the boundary conditions

at $x = 0$; $a = a_0$

thus, constant = $\log_e a_0$

or

$$\log_e a = \frac{\rho \cdot g \cdot x}{\sigma} + \log_e a_0$$

$$\log_e \left(\frac{a}{a_0} \right) = \frac{\rho \cdot g \cdot x}{\sigma}$$

$$\text{or } \boxed{e^{\frac{\rho \cdot g \cdot x}{\sigma}} = \frac{a}{a_0}}$$

also at $x = 0$

$$\sigma = \frac{P}{a_0}$$

Thus,

$$\frac{a}{a_0} = e^{\frac{\rho \cdot g \cdot x \cdot a_0}{P}}$$

The same results are obtained if the bar is turned upside down and loaded as a column as shown in the figure below:

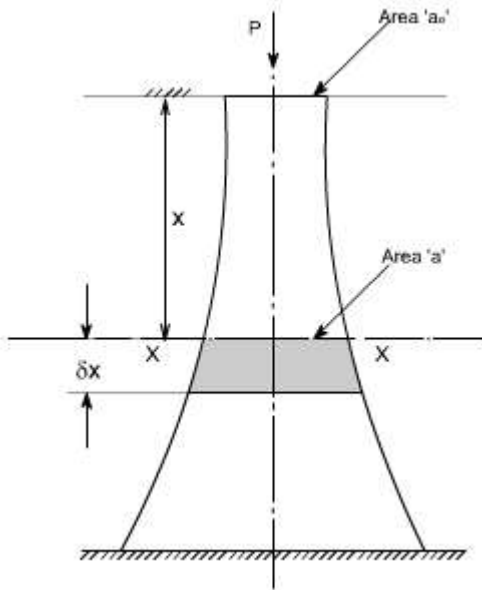

Illustrative Problem 1: Calculate the overall change in length of the tapered rod as shown in figure below. It carries a tensile load of 10kN at the free end and at the step change in section a compressive load of 2 MN/m evenly distributed around a circle of 30 mm diameter take the value of $E = 208 \text{ GN} / \text{m}^2$.

This problem may be solved using the procedure as discussed earlier in this section

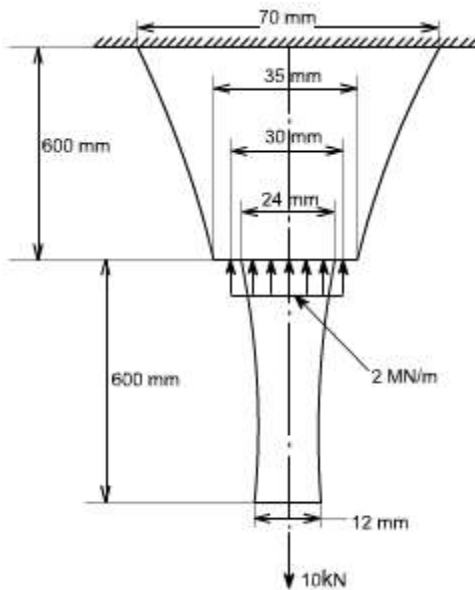

Illustrative Problem 2: A round bar, of length L , tapers uniformly from radius r_1 at one end to radius r_2 at the other. Show that the extension produced by a tensile axial load P

$$\text{is } \frac{PL}{2\pi E r_1^2}$$

If $r_2 = 2r_1$, compare this extension with that of a uniform cylindrical bar having a radius equal to the mean radius of the tapered bar.

Solution:

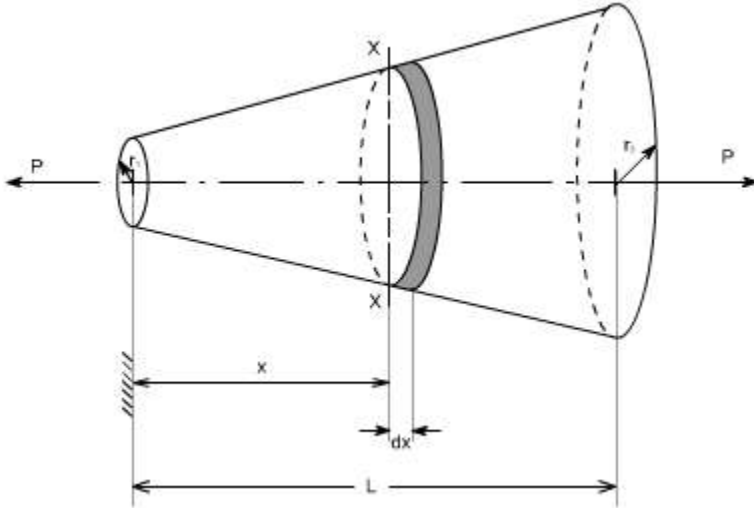

consider the above figure let r_1 be the radius at the smaller end. Then at a X crosssection XX located at a distance x from the smaller end, the value of radius is equal to

$$= r_1 + \frac{x}{L}(r_2 - r_1)$$

$$= r_1(1 + kx)$$

$$\text{where } k = \left(\frac{r_2 - r_1}{L}\right) \cdot \frac{1}{r_1}$$

$$\begin{aligned} \text{stress at section XX} &= \frac{\text{load}}{\text{area}} \\ &= \frac{P}{\pi r_1^2 (1 + kx)^2} \end{aligned}$$

$$\begin{aligned} \text{hence strain at this section} &= \frac{\text{stress}}{E} \\ &= \frac{P}{E \pi r_1^2 (1 + kx)^2} \end{aligned}$$

Thus, for a small length dx of the bar at this section the extension is $\frac{P \cdot dx}{E \pi r_1^2 (1 + kx)^2}$

Total extension of the bar can be found by integrating the above expression within the limits from $x=0$ to $x=L$

$$\text{Extension} = \int_0^L \frac{P \cdot dx}{E \pi r_1^2 (1 + kx)^2}$$

$$= \frac{P}{E \pi r_1^2} \int_0^L (1 + kx)^{-2} dx$$

$$= \frac{P}{E \pi r_1^2} \left[\frac{(1 + kx)^{-1}}{-k} \right]_0^L$$

$$= \frac{P}{E \pi r_1^2} \left[\frac{(1 + kL)^{-1}}{-k} - \frac{1}{-k} \right]$$

$$= \frac{P}{E \pi r_1^2 k} \left[1 - \frac{1}{1 + kL} \right]$$

$$= \frac{PL}{E \pi r_1^2 (1 + kL)}$$

$$\text{since } k = \frac{(r_2 - r_1)}{r_1 L}$$

$$\text{Thus, } 1 + kL = \frac{r_2}{r_1}$$

$$\text{Therefore, the extension} = \frac{PL}{\pi E r_1 r_2}$$

Comparing of extensions

For the case when $r_2 = 2r_1$, the value of computed extension as above becomes equal to

$$\frac{PL}{2\pi E r_1^2}$$

The mean radius of taper bar

$$= 1/2(r_1 + r_2)$$

$$= 1/2(r_1 + 2r_2)$$

$$= 3/2 \cdot r_1$$

Therefore, the extension of uniform bar

$$= \text{Original length} \cdot \text{strain}$$

$$= L \cdot \frac{\sigma}{E}$$

$$= \frac{L}{E} \cdot \frac{P}{\pi \left(\frac{3}{2}r_1\right)^2}$$

$$= \frac{4PL}{9\pi E r_1^2}$$

hence the

$$\frac{\text{Extension of uniform}}{\text{Extension of tapered}} = \left(\frac{4PL}{9\pi E r_1^2} \right) \bigg/ \frac{PL}{2\pi E r_1^2}$$

$$= \frac{8}{9}$$

LECTURE 14

Thermal stresses, Bars subjected to tension and Compression

Compound bar: In certain application it is necessary to use a combination of elements or bars made from different materials, each material performing a different function. In overhead electric cables or Transmission Lines for example it is often convenient to carry the current in a set of copper wires surrounding steel wires. The latter being designed to support the weight of the cable over large spans. Such a combination of materials is generally termed compound bars.

Consider therefore, a compound bar consisting of n members, each having a different length and cross sectional area and each being of a different material. Let all member have a common extension 'x' i.e. the load is positioned to produce the same extension in each member.

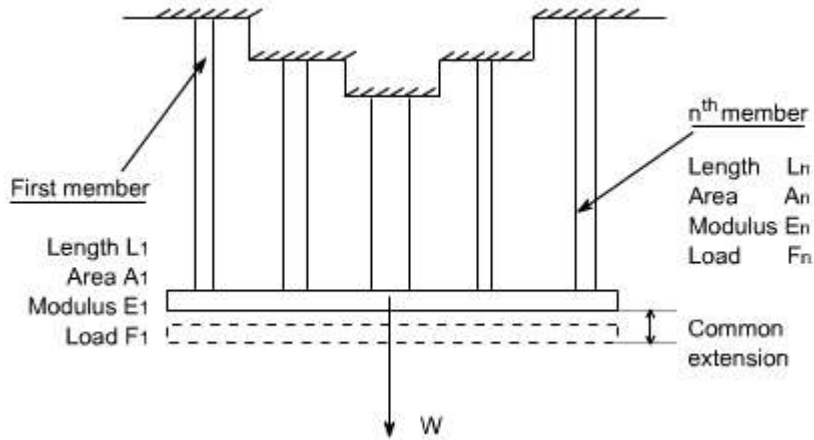

For the 'n' the members

$$\frac{\text{stress}}{\text{strain}} = E_n = \frac{F_n/A_n}{x_n/L_n}$$

$$= \frac{F_n \cdot L_n}{A_n \cdot x_n}$$

or $F_n = \frac{E_n \cdot A_n \cdot x_n}{L_n} = \frac{E_n \cdot A_n \cdot x}{L_n} \dots (1)$

Where \$F_n\$ is the force in the \$n^{th}\$ member and \$A_n\$ and \$L_n\$ are its cross - sectional area and length.

Let \$W\$ be the total load, the total load carried will be the sum of all loads for all the members.

$$W = \sum \frac{E_n \cdot A_n \cdot x}{L_n}$$

$$= x \cdot \sum \frac{E_n \cdot A_n}{L_n} \dots (2)$$

From equation (1), force in member 1 is given as

$$F_1 = \frac{E_1 \cdot A_1 \cdot x}{L_1}$$

from equation (2)

$$x = \frac{W}{\sum \frac{E_n \cdot A_n}{L_n}}$$

$$\text{Thus, } F_1 = \frac{E_1 \cdot A_1}{L_1} \cdot \frac{W}{\sum \left(\frac{E_n \cdot A_n}{L_n} \right)}$$

Therefore, each member carries a portion of the total load \$W\$ proportional of \$EA / L\$

value.

$$F_1 = \frac{\frac{E_1 \cdot A_1}{L_1}}{\sum \frac{E_n \cdot A_n}{L_n}} \cdot W$$

The above expression may be written as

if the length of each individual member is same then, we may write $F_1 = \frac{E_1 \cdot A_1}{\sum E \cdot A} \cdot W$

Thus, the stress in member '1' may be determined as $s_1 = F_1 / A_1$

Determination of common extension of compound bars: In order to determine the common extension of a compound bar it is convenient to consider it as a single bar of an imaginary material with an equivalent or combined modulus E_c .

Assumption: Here it is necessary to assume that both the extension and original lengths of the individual members of the compound bar are the same, the strains in all members will then be equal.

Total load on compound bar = $F_1 + F_2 + F_3 + \dots + F_n$

where F_1, F_2, \dots , etc are the loads in members 1, 2 etc

But force = stress . area, therefore

$$s (A_1 + A_2 + \dots + A_n) = s_1 A_1 + s_2 A_2 + \dots + s_n A_n$$

Where s is the stress in the equivalent single bar

Dividing throughout by the common strain $\hat{\epsilon}$.

$$\frac{\sigma}{\epsilon}(A_1 + A_2 + \dots + A_n) = \frac{\sigma_1}{\epsilon} A_1 + \frac{\sigma_2}{\epsilon} A_2 + \dots + \frac{\sigma_n}{\epsilon} A_n$$

ie $E_c(A_1 + A_2 + \dots + A_n) = E_1 A_1 + E_2 A_2 + \dots + E_n A_n$

or $E_c = \frac{E_1 A_1 + E_2 A_2 + \dots + E_n A_n}{A_1 + A_2 + \dots + A_n}$

or $E_c = \frac{\sum EA}{\sum A}$

with an external load W applied stress in the equivalent bar may be computed as

$$\text{stress} = \frac{W}{\sum A}$$

$$\text{strain in the equivalent bar} = \frac{x}{L} = \frac{W}{\sum A E_c}$$

$$\text{hence common extension } x = \frac{WL}{E_c \sum A}$$

Compound bars subjected to Temp. Change : Ordinary materials expand when heated and contract when cooled, hence , an increase in temperature produce a positive thermal strain. Thermal strains usually are reversible in a sense that the member returns to its original shape when the temperature return to its original value. However, there here are some materials which do not behave in this manner. These metals differs from ordinary materials in a sence that the strains are related non linearly to temperature and some times are irreversible .when a material is subjected to a change in temp. is a length will change by an amount.

$$d_t = a .L.t$$

$$\text{or } \hat{I}_t = a .L.t \text{ or } s_t = E .a.t$$

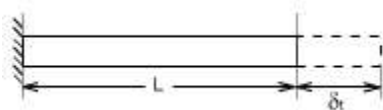

a = coefficient of linear expansoin for the material

L = original Length

t = temp. change

Thus an increase in temperature produces an increase in length and a decrease in temperature results in a decrease in length except in very special cases of materials with zero or negative coefficients of expansion which need not to be considered here.

If however, the free expansion of the material is prevented by some external force, then a stress is set up in the material. They stress is equal in magnitude to that which would be produced in the bar by initially allowing the bar to its free length and then applying sufficient force to return the bar to its original length.

Change in Length = $\alpha L t$

Therefore, strain = $\alpha L t / L$

$$= \alpha t$$

Therefore, the stress generated in the material by the application of sufficient force to remove this strain

$$= \text{strain} \times E$$

or Stress = $E \alpha t$

Consider now a compound bar constructed from two different materials rigidly joined together, for simplicity.

Let us consider that the materials in this case are steel and brass.

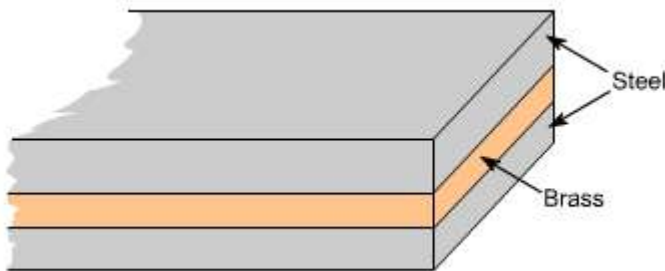

If we have both applied stresses and a temp. change, thermal strains may be added to those given by generalized hook's law equation –e.g.

$$\epsilon_x = \frac{1}{E} [\sigma_x - \nu(\sigma_y + \sigma_z)] + \alpha \Delta t$$

$$\epsilon_y = \frac{1}{E} [\sigma_y - \nu(\sigma_x + \sigma_z)] + \alpha \Delta t$$

$$\epsilon_z = \frac{1}{E} [\sigma_z - \nu(\sigma_x + \sigma_y)] + \alpha \Delta t$$

While the normal strains a body are affected by changes in temperatures, shear strains are not. Because if the temp. of any block or element changes, then its size changes not its shape therefore shear strains do not change.

In general, the coefficients of expansion of the two materials forming the compound bar will be different so that as the temp. rises each material will attempt to expand by different amounts. Figure below shows the positions to which the individual materials will expand if they are completely free to expand (i.e not joined rigidly together as a compound bar). The extension of any Length L is given by $\alpha L t$

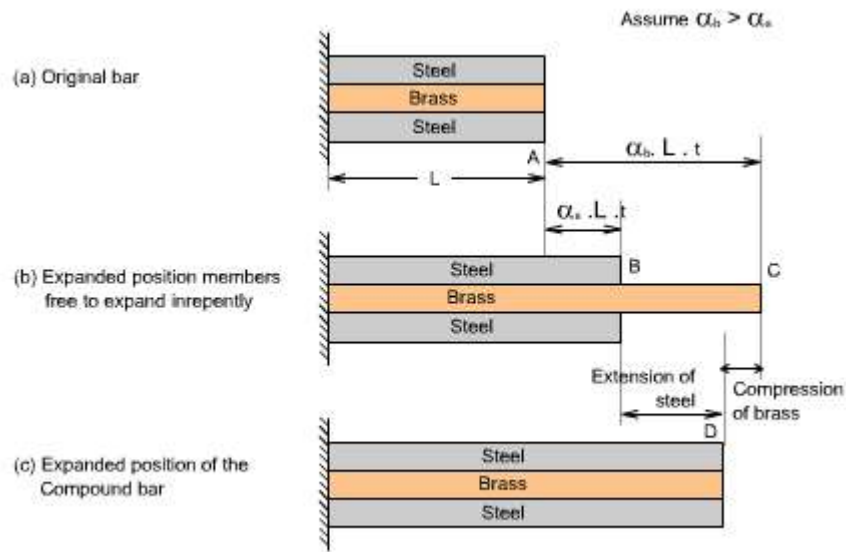

In general, changes in lengths due to thermal strains may be calculated from equation $d_t = \alpha L t$, provided that the members are able to expand or contract freely, a situation that exists in statically determinate structures. As a consequence no stresses are generated in a statically determinate structure when one or more members undergo a uniform temperature change. If in a structure (or a compound bar), the free expansion or contraction is not allowed then the member becomes statically indeterminate, which is just being discussed as an example of the compound bar and thermal stresses would be generated.

Thus the difference of free expansion lengths or so called free lengths

$$= \alpha_b L t - \alpha_s L t$$

$$= (\alpha_b - \alpha_s) L t$$

Since in this case the coefficient of expansion of the brass α_b is greater than that for the steel α_s , the initial lengths L of the two materials are assumed equal.

If the two materials are now rigidly joined as a compound bar and subjected to the same temp. rise, each material will attempt to expand to its free length position but each will be affected by the movement of the other. The higher coefficient of expansion material (brass) will therefore, seek to pull the steel up to its free length position and conversely, the lower coefficient of expansion material (steel) will try to hold the brass back. In practice a compromise is reached, the compound bar extending to the position shown in fig (c), resulting in an effective compression of the brass from its free length position and an effective extension of steel from its free length position.

Therefore, from the diagrams, we may conclude the following

Conclusion 1.

Extension of steel + compression brass = difference in “ free” length

Applying Newton 's law of equal action and reaction the following second Conclusion also holds good.

Conclusion 2.

The tensile force applied to the short member by the long member is equal in magnitude to the compressive force applied to long member by the short member.

Thus in this case

Tensile force in steel = compressive force in brass

These conclusions may be written in the form of mathematical equations as given below:

for conclusion1

$$\frac{\sigma_s \cdot L}{E_s} + \frac{\sigma_B \cdot L}{E_B} = (\alpha_B - \alpha_s) L \cdot t$$

for conclusion2

$$\sigma_s \cdot A_s = \sigma_B \cdot A_B$$

Using these two equations, the magnitude of the stresses may be determined.

LECTURE 15

Members Subjected to Axisymmetric Loads

Pressurized thin walled cylinder:

Preamble : Pressure vessels are exceedingly important in industry. Normally two types of pressure vessel are used in common practice such as cylindrical pressure vessel and spherical pressure vessel.

In the analysis of this walled cylinders subjected to internal pressures it is assumed that the radial plans remains radial and the wall thickness dose not change due to internal pressure. Although the internal pressure acting on the wall causes a local compressive stresses (equal to pressure) but its value is negligibly small as compared to other stresses & hence the sate of stress of an element of a thin walled pressure is considered a biaxial one.

Further in the analysis of them walled cylinders, the weight of the fluid is considered negligible.

Let us consider a long cylinder of circular cross - section with an internal radius of R_2 and a constant wall thickness 't' as showing fig.

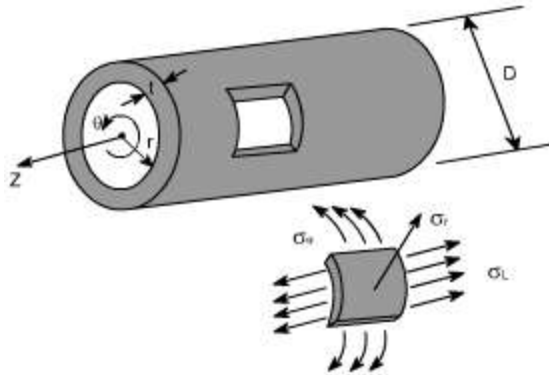

This cylinder is subjected to a difference of hydrostatic pressure of 'p' between its inner and outer surfaces. In many cases, 'p' between gage pressure within the cylinder, taking outside pressure to be ambient.

By thin walled cylinder we mean that the thickness 't' is very much smaller than the radius R_i and we may quantify this by stating that the ratio t / R_i of thickness of radius should be less than 0.1.

An appropriate co-ordinate system to be used to describe such a system is the cylindrical polar one r, θ, z shown, where z axis lies along the axis of the cylinder, r is radial to it and θ is the angular co-ordinate about the axis.

The small piece of the cylinder wall is shown in isolation, and stresses in respective direction have also been shown.

Type of failure:

Such a component fails in since when subjected to an excessively high internal pressure. While it might fail by bursting along a path following the circumference of the cylinder. Under normal circumstance it fails by circumstances it fails by bursting along a path parallel to the axis. This suggests that the hoop stress is significantly higher than the axial stress.

In order to derive the expressions for various stresses we make following

Applications :

Liquid storage tanks and containers, water pipes, boilers, submarine hulls, and certain air plane components are common examples of thin walled cylinders and spheres, roof domes.

ANALYSIS : In order to analyse the thin walled cylinders, let us make the following assumptions :

- There are no shear stresses acting in the wall.
- The longitudinal and hoop stresses do not vary through the wall.
- Radial stresses s_r which acts normal to the curved plane of the isolated element are

negligibly small as compared to other two stresses especially when $\left[\frac{t}{R_i} < \frac{1}{20} \right]$

The state of stress for an element of a thin walled pressure vessel is considered to be biaxial, although the internal pressure acting normal to the wall causes a local compressive stress equal to the internal pressure, Actually a state of tri-axial stress exists on the inside of the vessel. However, for then walled pressure vessel the third stress is much smaller than the other two stresses and for this reason in can be neglected.

Thin Cylinders Subjected to Internal Pressure:

When a thin – walled cylinder is subjected to internal pressure, three mutually

perpendicular principal stresses will be set up in the cylinder materials, namely

- Circumferential or hoop stress
- The radial stress
- Longitudinal stress

now let us define these stresses and determine the expressions for them

Hoop or circumferential stress:

This is the stress which is set up in resisting the bursting effect of the applied pressure and can be most conveniently treated by considering the equilibrium of the cylinder.

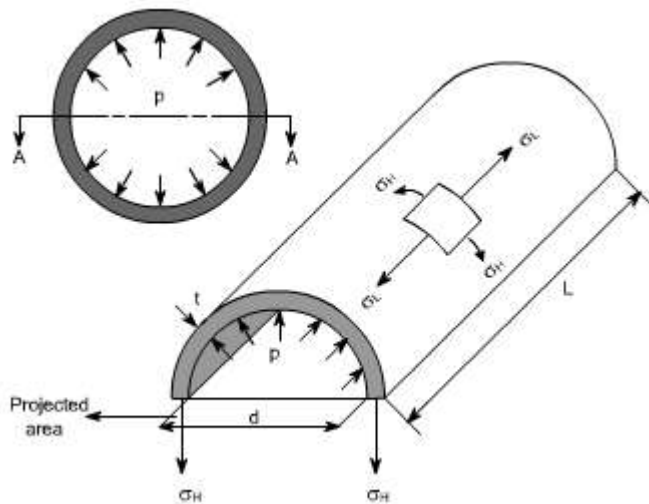

In the figure we have shown a one half of the cylinder. This cylinder is subjected to an internal pressure p.

- i.e. p = internal pressure
- d = inside diameter
- L = Length of the cylinder
- t = thickness of the wall

Total force on one half of the cylinder owing to the internal pressure 'p'
 = p x Projected Area
 = p x d x L
 = **p .d. L** ----- (1)

The total resisting force owing to hoop stresses s_H set up in the cylinder walls
 = **2 .s_H .L.t** -----(2)

Because $s_H.L.t$ is the force in the one wall of the half cylinder.
 the equations (1) & (2) we get

$$2 \cdot s_H \cdot L \cdot t = p \cdot d \cdot L$$

$$s_H = (p \cdot d) / 2t$$

<p>Circumferential or hoop Stress (s_H) = (p .d)/ 2t</p>
--

Longitudinal Stress:

Consider now again the same figure and the vessel could be considered to have closed ends and contains a fluid under a gage pressure p. Then the walls of the cylinder will have a longitudinal stress as well as a circumferential stress.

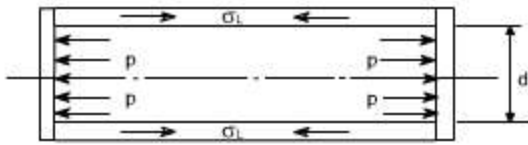

Total force on the end of the cylinder owing to internal pressure
 = pressure x area
 = $p \times \frac{\pi d^2}{4}$

Area of metal resisting this force = $\pi d \cdot t$. (approximately)
 because πd is the circumference and this is multiplied by the wall thickness

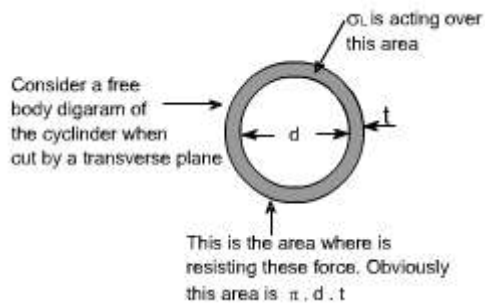

Hence the longitudinal stresses

$$\text{Set up} = \frac{\text{force}}{\text{area}} = \frac{[p \times \frac{\pi d^2}{4}]}{\pi d t}$$

$$= \frac{p d}{4 t} \quad \text{or} \quad \sigma_L = \frac{p d}{4 t}$$

or alternatively from equilibrium conditions

$$\sigma_L \cdot (\pi d t) = p \cdot \frac{\pi d^2}{4}$$

Thus $\sigma_L = \frac{p d}{4 t}$

LECTURE 16

Change in Dimensions :

The change in length of the cylinder may be determined from the longitudinal strain.

Since whenever the cylinder will elongate in axial direction or longitudinal direction, this will also get decreased in diameter or the lateral strain will also take place. Therefore we will have to also take into consideration the lateral strain. as we know that the poisson's ratio (ν) is

$$\nu = \frac{- \text{lateral strain}}{\text{longitudinal strain}}$$

where the -ve sign emphasized that the change is negative

Consider an element of cylinder wall which is subjected to two mutually \perp normal stresses s_L and s_H .

Let E = Young's modulus of elasticity

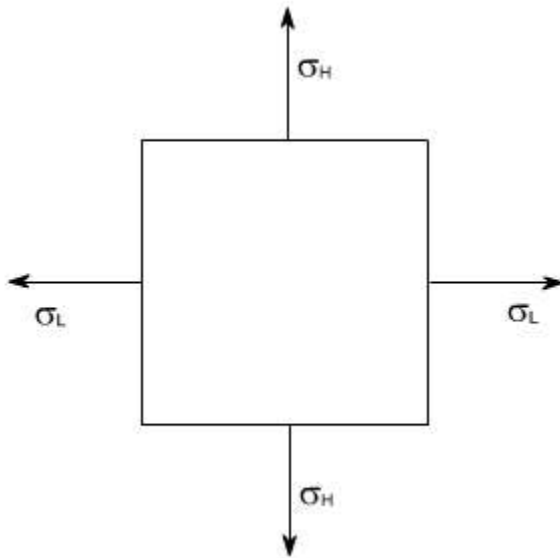

$$\text{Resultant Strain in longitudinal direction} = \frac{\sigma_L}{E} - \nu \frac{\sigma_H}{E} = \frac{1}{E} (\sigma_L - \nu \sigma_H)$$

recalling

$$\sigma_L = \frac{pd}{4t} \quad \sigma_H = \frac{pd}{2t}$$

$$\epsilon_1 \text{ (longitudinal strain)} = \frac{pd}{4Et} [1-2\nu]$$

or

$$\begin{aligned} \text{Change in Length} &= \text{Longitudinal strain} \times \text{original Length} \\ &= \epsilon_1 \cdot L \end{aligned}$$

$$\text{Similarly the hoop Strain } \epsilon_2 = \frac{1}{E} (\sigma_H - \nu \sigma_L) = \frac{1}{E} \left[\frac{pd}{2t} - \nu \frac{pd}{4t} \right]$$

$$\epsilon_2 = \frac{pd}{4Et} [2-\nu]$$

In fact ϵ_2 is the hoop strain if we just go by the definition then

$$\epsilon_2 = \frac{\text{Change in diameter}}{\text{Original diameter}} = \frac{\delta d}{d}$$

where d = original diameter.

if we are interested to find out the change in diameter then

$$\text{Change in diameter} = \epsilon_2 \cdot \text{Original diameter}$$

i.e $\delta d = \epsilon_2 \cdot d$ substituting the value of ϵ_2 we get

$$\delta d = \frac{p \cdot d}{4 \cdot t \cdot E} [2-\nu] \cdot d$$

$$= \frac{p \cdot d^2}{4 \cdot t \cdot E} [2-\nu]$$

$$\text{i.e } \boxed{\delta d = \frac{p \cdot d^2}{4 \cdot t \cdot E} [2-\nu]}$$

Volumetric Strain or Change in the Internal Volume:

When the thin cylinder is subjected to the internal pressure as we have already calculated that there is a change in the cylinder dimensions i.e, longitudinal strain and hoop strains come into picture. As a result of which there will be change in capacity of the cylinder or there is a change in the volume of the cylinder hence it becomes imperative to determine the change in volume or the volumetric strain.

The capacity of a cylinder is defined as

$$V = \text{Area} \times \text{Length}$$

$$= \frac{pd^2}{4} \times L$$

Let there be a change in dimensions occurs, when the thin cylinder is subjected to an internal pressure.

(i) The diameter d changes to $d + \delta d$

(ii) The length L changes to $L + \delta L$

Therefore, the change in volume = Final volume - Original volume

$$= \frac{\pi}{4} [d + \delta d]^2 \cdot (L + \delta L) - \frac{\pi}{4} d^2 \cdot L$$

$$\text{Volumetric strain} = \frac{\text{Change in volume}}{\text{Original volume}} = \frac{\frac{\pi}{4} [d + \delta d]^2 \cdot (L + \delta L) - \frac{\pi}{4} d^2 \cdot L}{\frac{\pi}{4} d^2 \cdot L}$$

$$\epsilon_v = \frac{\{ [d + \delta d]^2 \cdot (L + \delta L) - d^2 \cdot L \}}{d^2 \cdot L} = \frac{\{ (d^2 + \delta d^2 + 2d \cdot \delta d) \cdot (L + \delta L) - d^2 \cdot L \}}{d^2 \cdot L}$$

simplifying and neglecting the products and squares of small quantities, i.e. δd & δL hence

$$= \frac{2d \cdot \delta d \cdot L + \delta L \cdot d^2}{d^2 L} = \frac{\delta L}{L} + 2 \cdot \frac{\delta d}{d}$$

By definition $\frac{\delta L}{L} = \text{Longitudinal strain}$

$\frac{\delta d}{d} = \text{hoop strain, Thus}$

Volumetric strain = longitudinal strain + 2 x hoop strain

on substituting the value of longitudinal and hoop strains we get

$$\epsilon_1 = \frac{pd}{4tE} [1 - 2\nu] \quad \& \quad \epsilon_2 = \frac{pd}{4tE} [1 - 2\nu]$$

$$\text{or Volumetric} = \epsilon_1 + 2\epsilon_2 = \frac{pd}{4tE} [1 - 2\nu] + 2 \cdot \left(\frac{pd}{4tE} [1 - 2\nu] \right)$$

$$= \frac{pd}{4tE} \{ 1 - 2\nu + 4 - 2\nu \} = \frac{pd}{4tE} [5 - 4\nu]$$

$$\text{Volumetric Strain} = \frac{pd}{4tE} [5 - 4\nu] \quad \text{or} \quad \boxed{\epsilon_v = \frac{pd}{4tE} [5 - 4\nu]}$$

Therefore to find but the increase in capacity or volume, multiply the volumetric strain by original volume.

Hence

Change in Capacity / Volume or

$$\boxed{\text{Increase in volume} = \frac{pd}{4tE} [5 - 4\nu] V}$$

LECTURE 17

Cylindrical Vessel with Hemispherical Ends:

Let us now consider the vessel with hemispherical ends. The wall thickness of the cylindrical and hemispherical portion is different. While the internal diameter of both the portions is assumed to be equal

Let the cylindrical vessel is subjected to an internal pressure p .

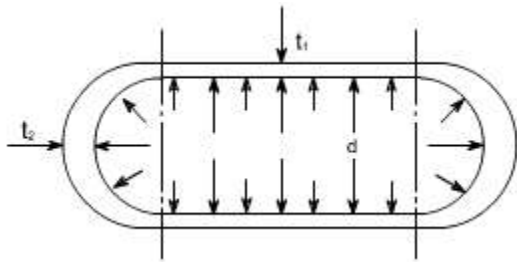

For the Cylindrical Portion

hoop or circumferential stress = σ_{HC} 'c' here signifies the cylindrical portion.

$$= \frac{pd}{2t_1}$$

longitudinal stress = σ_{LC}

$$= \frac{pd}{4t_1}$$

hoop or circumferential strain $\epsilon_2 = \frac{\sigma_{HC}}{E} - \nu \frac{\sigma_{LC}}{E} = \frac{pd}{4t_1 E} [2 - \nu]$

or
$$\epsilon_2 = \frac{pd}{4t_1 E} [2 - \nu]$$

For The Hemispherical Ends:

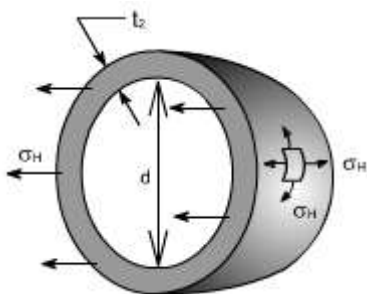

Because of the symmetry of the sphere the stresses set up owing to internal pressure will be two mutually perpendicular hoops or circumferential stresses of equal values. Again the radial stresses are neglected in comparison to the hoop stresses as with this cylinder

having thickness to diameter less than 1:20.

Consider the equilibrium of the half – sphere

Force on half-sphere owing to internal pressure = pressure x projected Area

$$= p \cdot \frac{\pi d^2}{4}$$

$$\text{Resisting force} = \sigma_H \cdot \pi d \cdot t_2$$

$$\therefore p \cdot \frac{\pi d^2}{4} = \sigma_H \cdot \pi d \cdot t_2$$

$$\Rightarrow \sigma_H \text{ (for sphere)} = \frac{pd}{4t_2}$$

$$\text{similarly the hoop strain} = \frac{1}{E} [\sigma_H - \nu \sigma_H] = \frac{\sigma_H}{E} [1 - \nu] = \frac{pd}{4t_2 E} [1 - \nu] \text{ or } \epsilon_{2s} = \frac{pd}{4t_2 E} [1 - \nu]$$



Fig – shown the (by way of dotted lines) the tendency, for the cylindrical portion and the spherical ends to expand by a different amount under the action of internal pressure. So owing to difference in stress, the two portions (i.e. cylindrical and spherical ends) expand by a different amount. This incompatibility of deformations causes a local bending and shearing stresses in the neighborhood of the joint. Since there must be physical continuity between the ends and the cylindrical portion, for this reason, properly curved ends must be used for pressure vessels.

Thus equating the two strains in order that there shall be no distortion of the junction

$$\frac{pd}{4t_1 E} [2 - \nu] = \frac{pd}{4t_2 E} [1 - \nu] \text{ or } \frac{t_2}{t_1} = \frac{1 - \nu}{2 - \nu}$$

But for general steel works $\nu = 0.3$, therefore, the thickness ratios becomes

$$t_2 / t_1 = 0.7/1.7 \text{ or}$$

$$t_1 = 2.4 t_2$$

i.e. the thickness of the cylinder walls must be approximately 2.4 times that of the hemispheroid ends for no distortion of the junction to occur.

SUMMARY OF THE RESULTS : Let us summarise the derived results

(A) The stresses set up in the walls of a thin cylinder owing to an internal pressure p are :

(i) Circumferential or hoop stress

$$s_H = \frac{pd}{2t}$$

(ii) Longitudinal or axial stress

$$s_L = \frac{pd}{4t}$$

Where d is the internal diameter and t is the wall thickness of the cylinder.

then

$$\text{Longitudinal strain } \hat{\epsilon}_L = \frac{1}{E} [s_L - \nu s_H]$$

$$\text{Hoop strain } \hat{\epsilon}_H = \frac{1}{E} [s_H - \nu s_L]$$

(B) Change of internal volume of cylinder under pressure

$$= \frac{pd}{4tE} [5 - 4\nu] V$$

(C) For thin spheres circumferential or hoop stress

$$\sigma_H = \frac{pd}{4t}$$

Thin rotating ring or cylinder

Consider a thin ring or cylinder as shown in Fig below subjected to a radial internal pressure p caused by the centrifugal effect of its own mass when rotating. The centrifugal effect on a unit length of the circumference is

$$p = m w^2 r$$

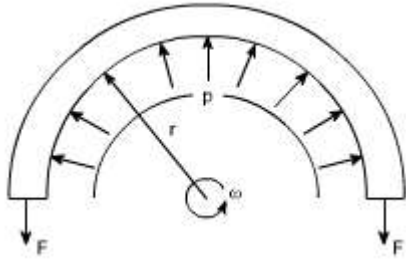

Fig 19.1: Thin ring rotating with constant angular velocity ω

Here the radial pressure 'p' is acting per unit length and is caused by the centrifugal effect if its own mass when rotating.

Thus considering the equilibrium of half the ring shown in the figure,

$2F = p \times 2r$ (assuming unit length), as $2r$ is the projected area

$$F = pr$$

Where F is the hoop tension set up owing to rotation.

The cylinder wall is assumed to be so thin that the centrifugal effect can be assumed constant across the wall thickness.

$$F = \text{mass} \times \text{acceleration} = m \omega^2 r \times r$$

This tension is transmitted through the complete circumference and therefore is resisted by the complete cross – sectional area.

$$\text{hoop stress} = F/A = m \omega^2 r^2 / A$$

Where A is the cross – sectional area of the ring.

Now with unit length assumed m/A is the mass of the material per unit volume, i.e. the density ρ .

$$\text{hoop stress} = \rho \omega^2 r^2$$

$$s_H = \rho \cdot \omega^2 \cdot r^2$$

LECTURE 18

Members Subjected to Torsional Loads

Torsion of circular shafts

Definition of Torsion: Consider a shaft rigidly clamped at one end and twisted at the other end by a torque $T = F.d$ applied in a plane perpendicular to the axis of the bar such a shaft is said to be in torsion.

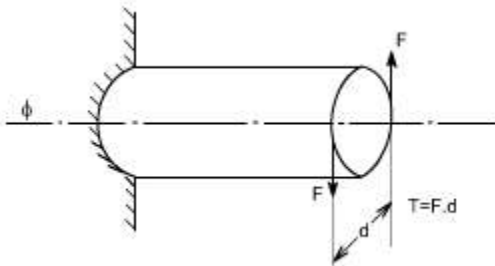

Effects of Torsion: The effects of a torsional load applied to a bar are

- (i) To impart an angular displacement of one end cross – section with respect to the other end.
- (ii) To setup shear stresses on any cross section of the bar perpendicular to its axis.

GENERATION OF SHEAR STRESSES

The physical understanding of the phenomena of setting up of shear stresses in a shaft subjected to a torsion may be understood from the figure 1-3.

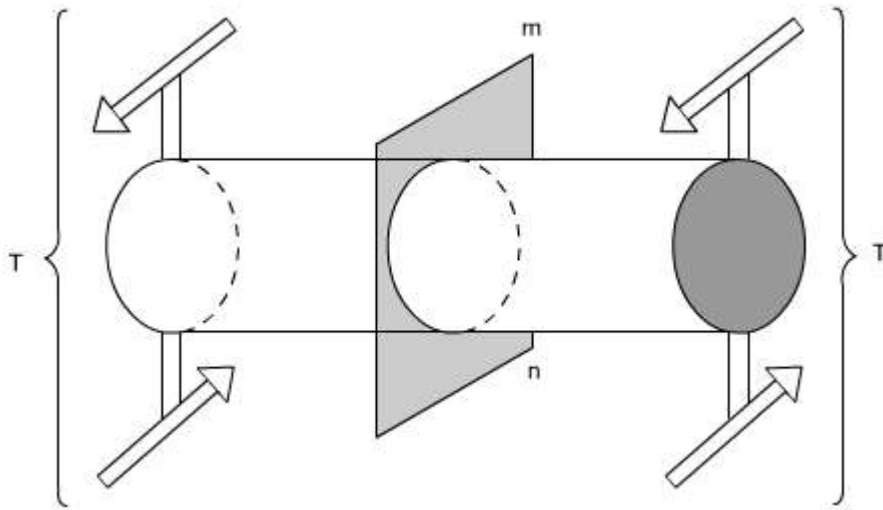

Fig 1: Here the cylindrical member or a shaft is in static equilibrium where T is the resultant external torque acting on the member. Let the member be imagined to be cut by some imaginary plane 'mn'.

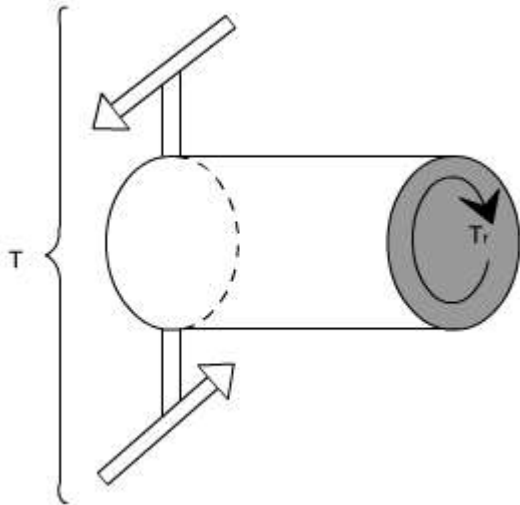

Fig 2: When the plane 'mn' cuts remove the portion on R.H.S. and we get a fig 2. Now since the entire member is in equilibrium, therefore, each portion must be in equilibrium. Thus, the member is in equilibrium under the action of resultant external torque T and developed resisting Torque T_r .

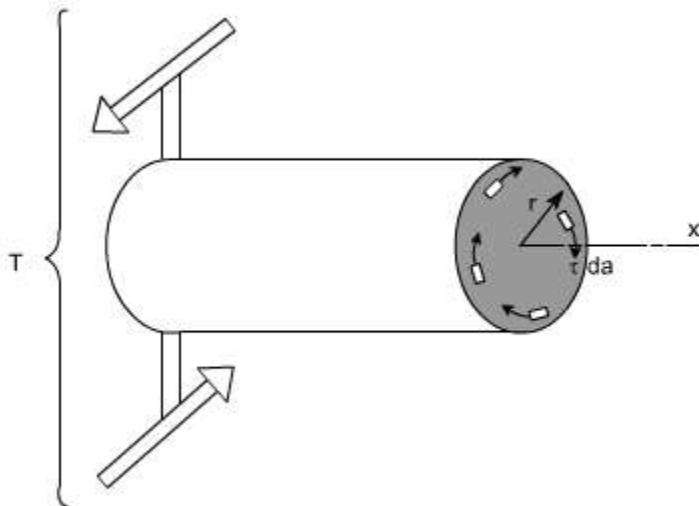

Fig 3: The Figure shows that how the resisting torque T_r is developed. The resisting torque T_r is produced by virtue of an infinitesimal shear forces acting on the plane perpendicular to the axis of the shaft. Obviously such shear forces would be developed by virtue of shear stresses.

Therefore we can say that when a particular member (say shaft in this case) is subjected to a torque, the result would be that on any element there will be shear stresses acting.

While on other faces the complementary shear forces come into picture. Thus, we can say that when a member is subjected to torque, an element of this member will be subjected to a state of pure shear.

Shaft: The shafts are the machine elements which are used to transmit power in machines.

Twisting Moment: The twisting moment for any section along the bar / shaft is defined to be the algebraic sum of the moments of the applied couples that lie to one side of the section under consideration. The choice of the side in any case is of course arbitrary.

Shearing Strain: If a generator $a - b$ is marked on the surface of the unloaded bar, then after the twisting moment 'T' has been applied this line moves to ab' . The angle 'g' measured in radians, between the final and original positions of the generators is defined as the shearing strain at the surface of the bar or shaft. The same definition will hold at any interior point of the bar.

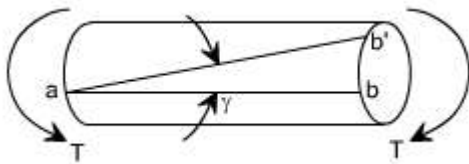

Modulus of Elasticity in shear: The ratio of the shear stress to the shear strain is called the modulus of elasticity in shear OR Modulus of Rigidity and is represented by the

symbol $G = \frac{\tau}{r}$

Angle of Twist: If a shaft of length L is subjected to a constant twisting moment T along its length, then the angle ϕ through which one end of the bar will twist relative to the other is known as the angle of twist.

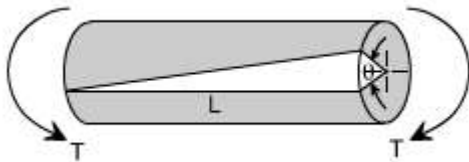

- Despite the differences in the forms of loading, we see that there are number of similarities between bending and torsion, including for example, a linear variation of stresses and strain with position.

In torsion the members are subjected to moments (couples) in planes normal to their axes.

- For the purpose of designing a circular shaft to withstand a given torque, we must develop an equation giving the relation between twisting moment, maximum shear stress produced, and a quantity representing the size and shape of the cross-sectional area of the shaft.

Not all torsion problems, involve rotating machinery, however, for example some types of vehicle suspension system employ torsional springs. Indeed, even coil springs are really curved members in torsion as shown in figure.

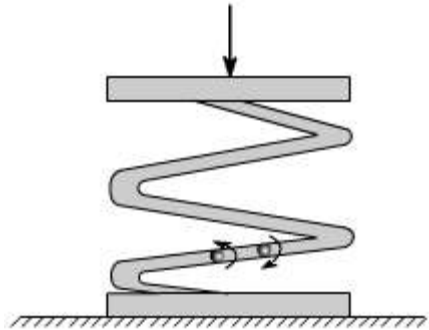

- Many torque carrying engineering members are cylindrical in shape. Examples are drive shafts, bolts and screw drivers.

Simple Torsion Theory or Development of Torsion Formula : Here we are basically interested to derive an equation between the relevant parameters

$$\frac{T}{J} = \frac{\tau}{r} = \frac{G\theta}{l}$$

Relationship in Torsion:

1 st Term: It refers to applied loading and a property of section, which in the instance is the polar second moment of area.

2 nd Term: This refers to stress, and the stress increases as the distance from the axis increases.

3 rd Term: it refers to the deformation and contains the terms modulus of rigidity & combined term (q / l) which is equivalent to strain for the purpose of designing a circular shaft to withstand a given torque we must develop an equation giving the relation between Twisting moments max m shear stain produced and a quantity representing the size and shape of the cross – sectional area of the shaft.

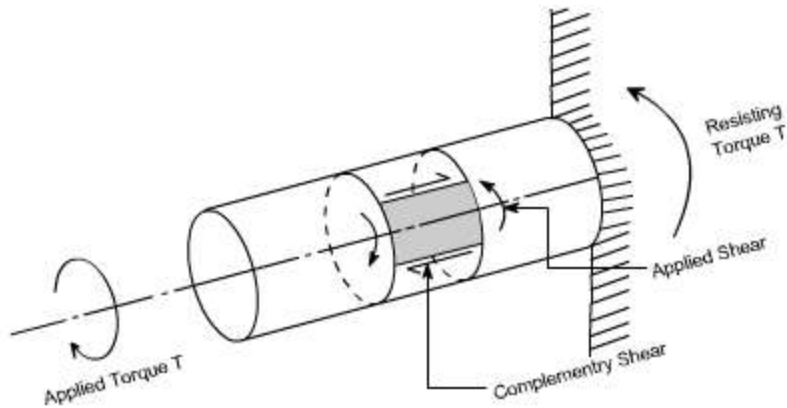

Refer to the figure shown above where a uniform circular shaft is subjected to a torque it can be shown that every section of the shaft is subjected to a state of pure shear, the moment of resistance developed by the shear stresses being every where equal to the magnitude, and opposite in sense, to the applied torque. For the purpose of deriving a simple theory to describe the behavior of shafts subjected to torque it is necessary make the following base assumptions.

Assumption:

- (i) The material is homogenous i.e of uniform elastic properties exists throughout the material.
- (ii) The material is elastic, follows Hook's law, with shear stress proportional to shear strain.
- (iii) The stress does not exceed the elastic limit.
- (iv) The circular section remains circular
- (v) Cross section remain plane.
- (vi) Cross section rotate as if rigid i.e. every diameter rotates through the same angle.

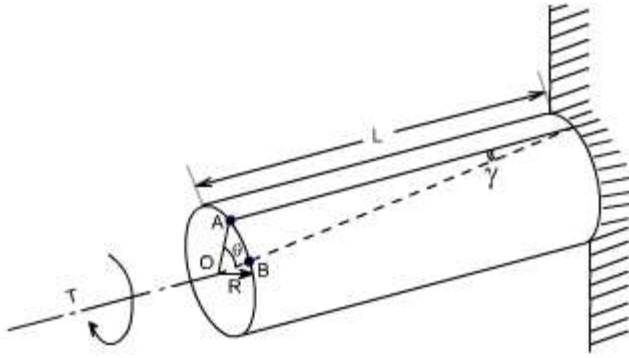

Consider now the solid circular shaft of radius R subjected to a torque T at one end, the other end being fixed. Under the action of this torque a radial line at the free end of the shaft twists through an angle q , point A moves to B , and AB subtends an angle ' g ' at the fixed end. This is then the angle of distortion of the shaft i.e the shear strain.

Since angle in radius = arc / Radius

$$\text{arc } AB = Rq$$

$$= L g \text{ [since } L \text{ and } g \text{ also constitute the arc } AB]$$

$$\text{Thus, } g = Rq / L \quad (1)$$

From the definition of Modulus of rigidity or Modulus of elasticity in shear

$$G = \frac{\text{shear stress}(\tau)}{\text{shear strain}(\gamma)}$$

where γ is the shear strain set up at radius R .

$$\text{Then } \frac{T}{G} = \gamma$$

$$\text{Equating the equations (1) and (2) we get } \frac{R\theta}{L} = \frac{\tau}{G}$$

$$\frac{\tau}{R} = \frac{G\theta}{L} \left(= \frac{\tau'}{r} \right) \text{ where } \tau' \text{ is the shear stress at any radius } r.$$

Stresses: Let us consider a small strip of radius r and thickness dr which is subjected to shear stress τ' .

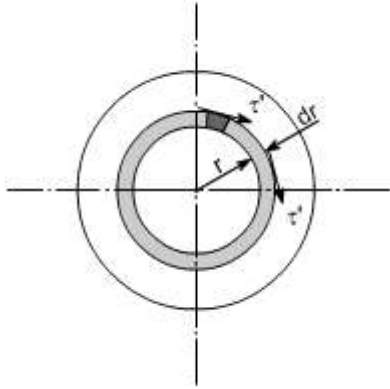

The force set up on each element

= stress x area

= $t' \times 2\pi r dr$ (approximately)

This force will produce a moment or torque about the center axis of the shaft.

= $t' \cdot 2\pi r dr \cdot r$

= $2\pi t' \cdot r^2 \cdot dr$

The total torque T on the section, will be the sum of all the contributions.

$$T = \int_0^R 2\pi r^2 t' dr$$

Since t' is a function of r , because it varies with radius so writing down t' in terms of r from the equation (1).

$$\text{i.e. } \tau' = \frac{G\theta r}{L}$$

$$\text{we get } T = \int_0^R 2\pi \frac{G\theta}{L} r^3 dr$$

$$T = \frac{2\pi G\theta}{L} \int_0^R r^3 dr$$

$$= \frac{2\pi G\theta}{L} \left[\frac{R^4}{4} \right]_0^R$$

$$= \frac{G\theta}{L} \cdot \frac{2\pi R^4}{4}$$

$$= \frac{G\theta}{L} \cdot \frac{\pi R^4}{2}$$

$$= \frac{G\theta}{L} \left[\frac{\pi d^4}{32} \right] \text{ now substituting } R = d/2$$

$$= \frac{G\theta}{L} J$$

since $\frac{\pi d^4}{32} = J$ the polar moment of inertia

$$\text{or } \frac{T}{J} = \frac{G\theta}{L} \quad \dots\dots(2)$$

if we combine the equation no.(1) and (2) we get $\boxed{\frac{T}{J} = \frac{\tau'}{r} = \frac{G\theta}{L}}$

Where

T = applied external Torque, which is constant over Length L;

J = Polar moment of Inertia

$$= \frac{\pi d^4}{32} \text{ for solid shaft}$$

$$= \frac{\pi(D^4 - d^4)}{32} \text{ for a hollow shaft. [D = Outside diameter ; d = inside diameter]}$$

G = Modulus of rigidity (or Modulus of elasticity in shear)

q = It is the angle of twist in radians on a length L.

Tensional Stiffness: The tensional stiffness k is defined as the torque per radius twist

$$\text{i.e. } k = T / q = GJ / L$$

Power Transmitted by a shaft : If T is the applied Torque and w is the angular velocity

of the shaft, then the power transmitted by the shaft is

$$P = T \cdot \omega = \frac{2\pi NT}{60} = \frac{2\pi NT}{60 \cdot 10^3} \text{ kW}$$

where N = rpm

LECTURE 19

Distribution of shear stresses in circular Shafts subjected to torsion :

The simple torsion equation is written as

$$\frac{T}{J} = \frac{\tau}{r} = \frac{G \cdot \theta}{L}$$

or

$$\tau = \frac{G \theta \cdot r}{L}$$

This states that the shearing stress varies directly as the distance 'r' from the axis of the shaft and the following is the stress distribution in the plane of cross section and also the complementary shearing stresses in an axial plane.

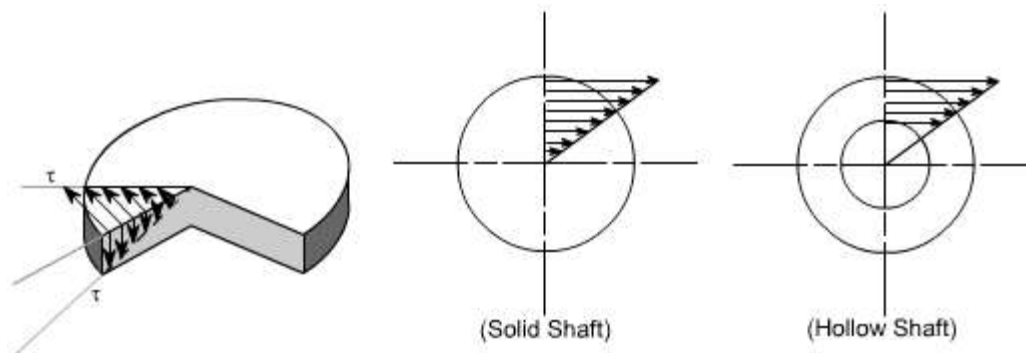

Hence the maximum shear stress occurs on the outer surface of the shaft where $r = R$

The value of maximum shearing stress in the solid circular shaft can be determined as

$$\frac{\tau}{r} = \frac{T}{J}$$

$$\tau_{\max} \text{ at } r = \frac{d}{2} = \frac{T.R}{J} = \frac{T}{\frac{\pi d^4}{32}} \cdot \frac{d}{2}$$

where d = diameter of solid shaft

$$\text{or } \tau_{\max} = \frac{16T}{\pi d^3}$$

From the above relation, following conclusion can be drawn

(i) $\tau_{\max} \propto T$

(ii) $\tau_{\max} \propto 1/d^3$

Power Transmitted by a shaft:

In practical application, the diameter of the shaft must sometimes be calculated from the power which it is required to transmit.

Given the power required to be transmitted, speed in rpm 'N' Torque T, the formula connecting

These quantities can be derived as follows

$$\begin{aligned} P &= T \cdot \omega \\ &= \frac{T \cdot 2\pi N}{60} \text{ watts} \\ &= \frac{2\pi NT}{60 \times 10^3} \text{ (kw)} \end{aligned}$$

Torsional stiffness: The torsional stiffness k is defined as the torque per radian twist .

$$\begin{aligned} k &= \frac{T}{\theta} \\ \text{i.e. } &= \frac{GJ}{L} \\ \text{or } k &= \frac{G \cdot J}{L} \end{aligned}$$

For a ductile material, the plastic flow begins first in the outer surface. For a material which is weaker in shear longitudinally than transversely – for instance a wooden shaft, with the fibres parallel to axis the first cracks will be produced by the shearing stresses acting in the axial section and they will appear on the surface of the shaft in the longitudinal direction.

In the case of a material which is weaker in tension than in shear. For instance a, circular shaft of cast iron or a cylindrical piece of chalk a crack along a helix inclined at 45° to the axis of shaft often occurs.

Explanation: This is because of the fact that the state of pure shear is equivalent to a state of stress tension in one direction and equal compression in perpendicular direction.

A rectangular element cut from the outer layer of a twisted shaft with sides at 45° to the axis will be subjected to such stresses, the tensile stresses shown will produce a helical crack mentioned.

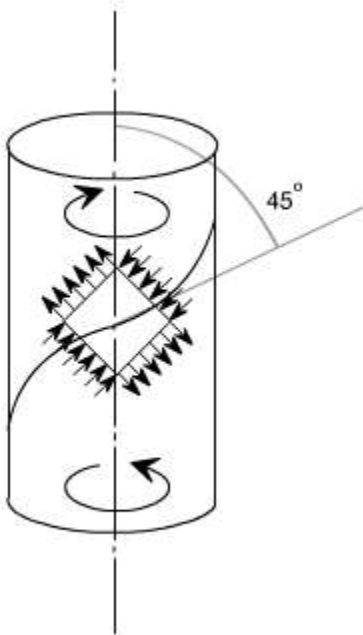

TORSION OF HOLLOW SHAFTS:

From the torsion of solid shafts of circular x – section , it is seen that only the material at the outer surface of the shaft can be stressed to the limit assigned as an allowable working stresses. All of the material within the shaft will work at a lower stress and is not being used to full capacity. Thus, in these cases where the weight reduction is important, it is advantageous to use hollow shafts. In discussing the torsion of hollow shafts the same assumptions will be made as in the case of a solid shaft. The general torsion equation as we have applied in the case of torsion of solid shaft will hold good

$$\frac{T}{J} = \frac{\tau}{r} = \frac{G.\theta}{l}$$

For the hollow shaft

$$J = \frac{\pi(D_0^4 - d_i^4)}{32} \quad \text{where } D_0 = \text{Outside diameter}$$

$d_i = \text{Inside diameter}$

$$\text{Let } d_i = \frac{1}{2}.D_0$$

$$\tau_{\max}^m \Big|_{\text{solid}} = \frac{16T}{\pi D_0^3} \quad (1)$$

$$\begin{aligned} \tau_{\max}^m \Big|_{\text{hollow}} &= \frac{T.D_0/2}{\frac{\pi}{32}(D_0^4 - d_i^4)} \\ &= \frac{16T.D_0}{\pi D_0^4 \left[1 - (d_i/D_0)^4\right]} \\ &= \frac{16T}{\pi D_0^3 \left[1 - (1/2)^4\right]} = 1.066 \cdot \frac{16T}{\pi D_0^3} \quad (2) \end{aligned}$$

Hence by examining the equation (1) and (2) it may be seen that the τ_{\max}^m in the case of hollow shaft is 6.6% larger than in the case of a solid shaft having the same outside diameter.

Reduction in weight:

Considering a solid and hollow shafts of the same length 'l' and density 'r' with $d_i = 1/2 D_0$

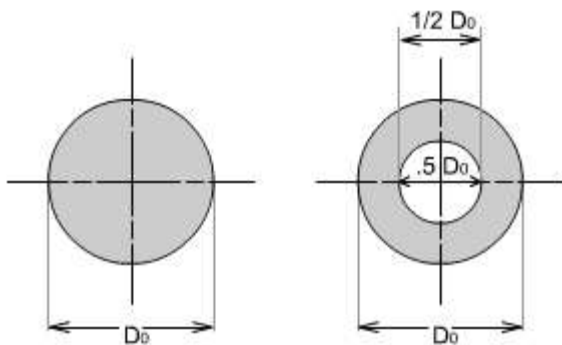

Weight of hollow shaft

$$\begin{aligned}
 &= \left[\frac{\pi D_0^2}{4} - \frac{\pi (D_0/2)^2}{4} \right] l \times \rho \\
 &= \left[\frac{\pi D_0^2}{4} - \frac{\pi D_0^2}{16} \right] l \times \rho \\
 &= \frac{\pi D_0^2}{4} [1 - 1/4] l \times \rho \\
 &= 0.75 \frac{\pi D_0^2}{4} l \times \rho
 \end{aligned}$$

$$\text{Weight of solid shaft} = \frac{\pi D_0^2}{4} l \times \rho$$

$$\begin{aligned}
 \text{Reduction in weight} &= (1 - 0.75) \frac{\pi D_0^2}{4} l \times \rho \\
 &= 0.25 \frac{\pi D_0^2}{4} l \times \rho
 \end{aligned}$$

Hence the reduction in weight would be just 25%.

Illustrative Examples :

Problem 1

A stepped solid circular shaft is built in at its ends and subjected to an externally applied torque, T_0 at the shoulder as shown in the figure. Determine the angle of rotation θ_0 of the shoulder section where T_0 is applied ?

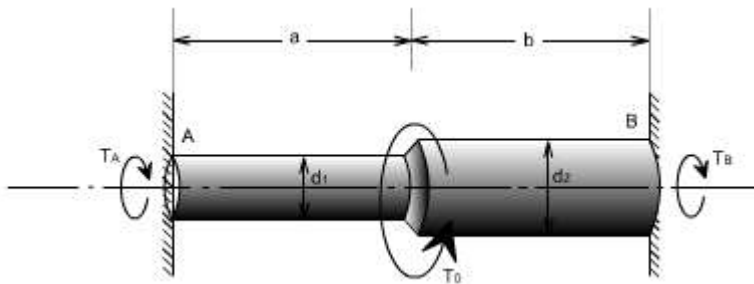

Solution: This is a statically indeterminate system because the shaft is built in at both ends. All that we can find from the statics is that the sum of two reactive torque T_A and T_B at the built – in ends of the shafts must be equal to the applied torque T_0

$$\text{Thus } T_A + T_B = T_0 \quad \text{----- (1)}$$

[from static principles]

Where T_A, T_B are the reactive torque at the built in ends A and B. whereas T_0 is the

applied torque

From consideration of consistent deformation, we see that the angle of twist in each portion of the shaft must be same.

i.e $\theta_a = \theta_b = \theta_0$

$$\begin{aligned} \frac{T}{J} &= \frac{G \cdot \theta}{L} \\ \text{or } \theta_A &= \frac{T_A a}{J_A G} \\ \theta_B &= \frac{T_B b}{J_B G} \\ \Rightarrow \frac{T_A a}{J_A G} &= \frac{T_B b}{J_B G} = \theta_0 \quad \text{or } \frac{T_A}{T_B} = \frac{J_A}{J_B} \cdot \frac{b}{a} \quad (2) \end{aligned}$$

using the relation for angle of twist

N.B: Assuming modulus of rigidity G to be same for the two portions

So the defines the ratio of T_A and T_B

So by solving (1) & (2) we get

$$T_A = \frac{T_0}{1 + \frac{J_B a}{J_A b}}$$

$$T_b = \frac{T_0}{1 + \frac{J_a b}{J_b a}}$$

Using either of these values in (2) we have the angle of rotation θ_0 at the junction

$$\theta_0 = \frac{T_0 \cdot a \cdot b}{[J_A \cdot b + J_B \cdot a] G}$$

Non Uniform Torsion: The pure torsion refers to a torsion of a prismatic bar subjected to torques acting only at the ends. While the non uniform torsion differs from pure torsion in a sense that the bar / shaft need not to be prismatic and the applied torques may vary along the length.

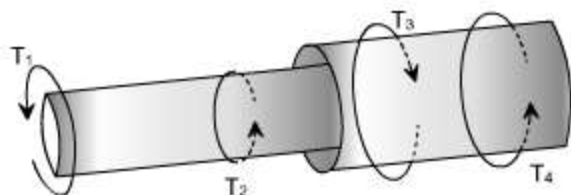

Here the shaft is made up of two different segments of different diameters and having

torques applied at several cross sections. Each region of the bar between the applied loads between changes in cross section is in pure torsion, hence the formula's derived earlier may be applied. Then from the internal torque, maximum shear stress and angle of rotation for each region can be calculated from the relation

$$\frac{T}{J} = \frac{\tau}{r} \text{ and } \frac{T}{J} = \frac{G\theta}{L}$$

The total angle to twist of one end of the bar with respect to the other is obtained by summation using the formula

$$\theta = \sum_{i=1}^n \frac{T_i L_i}{G_i J_i}$$

i = index for no. of parts

n = total number of parts

If either the torque or the cross section changes continuously along the axis of the bar, then the \sum (summation can be replaced by an integral sign (\int)). i.e We will have to consider a differential element.

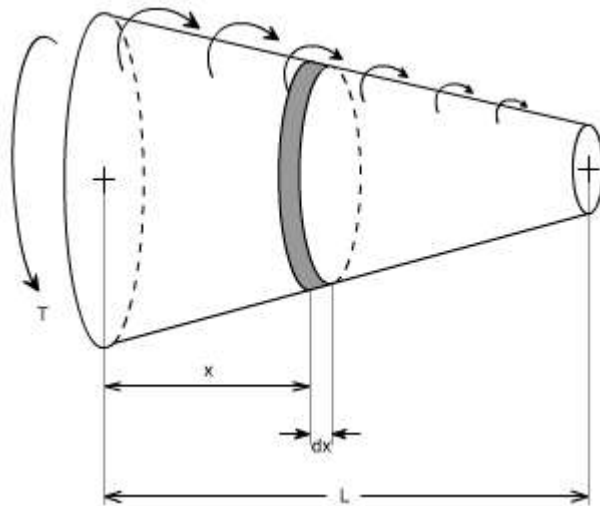

$$d\theta = \frac{T_x dx}{GJ_x}$$

After considering the differential element, we can write

Substituting the expressions for T_x and J_x at a distance x from the end of the bar, and then integrating between the limits 0 to L , find the value of angle of twist may be determined.

$$\theta = \int_0^L d\theta = \int_0^L \frac{T_x dx}{G I_x}$$

LECTURE 20

Closed Coiled helical springs subjected to axial loads:

Definition: A spring may be defined as an elastic member whose primary function is to deflect or distort under the action of applied load; it recovers its original shape when load is released.

or

Springs are energy absorbing units whose function is to store energy and to restore it slowly or rapidly depending on the particular application.

Important types of springs are:

There are various types of springs such as

(i) helical spring: They are made of wire coiled into a helical form, the load being applied along the axis of the helix. In these type of springs the major stresses is torsional shear stress due to twisting. They are both used in tension and compression.



(ii) Spiral springs: They are made of flat strip of metal wound in the form of spiral and loaded in torsion.

In this the major stresses are tensile and compression due to bending.

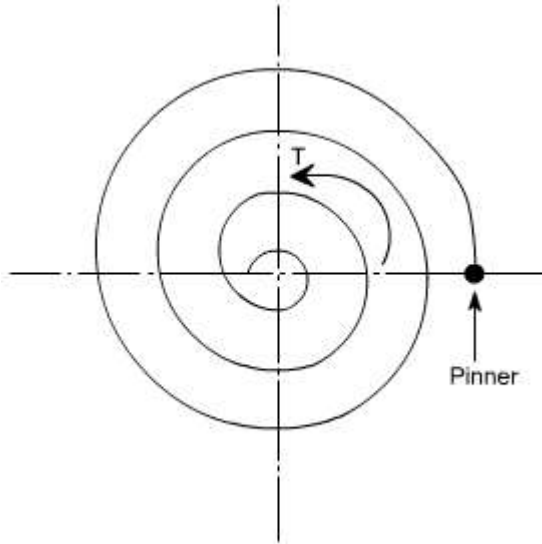

(iv) Leaf springs: They are composed of flat bars of varying lengths clamped together so as to obtain greater efficiency. Leaf springs may be full elliptic, semi elliptic or cantilever types, In these type of springs the major stresses which come into picture are tensile & compressive.

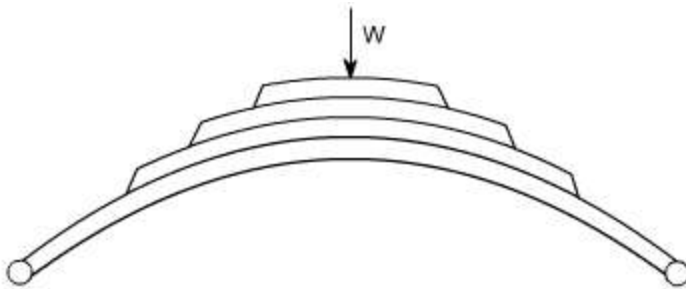

These type of springs are used in the automobile suspension system.

Uses of springs :

- (a) To apply forces and to control motions as in brakes and clutches.
- (b) To measure forces as in spring balance.
- (c) To store energy as in clock springs.
- (d) To reduce the effect of shock or impact loading as in carriage springs.
- (e) To change the vibrating characteristics of a member as inflexible mounting of motors.

Derivation of the Formula :

In order to derive a necessary formula which governs the behaviour of springs, consider a

closed coiled spring subjected to an axial load W .

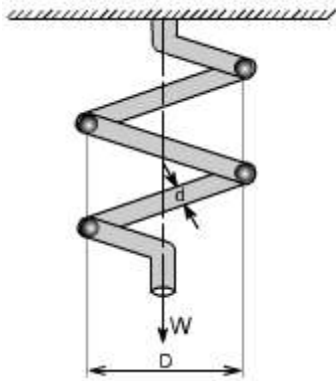

Let

W = axial load

D = mean coil diameter

d = diameter of spring wire

n = number of active coils

C = spring index = D / d For circular wires

l = length of spring wire

G = modulus of rigidity

x = deflection of spring

q = Angle of twist

when the spring is being subjected to an axial load to the wire of the spring gets be twisted like a shaft.

If q is the total angle of twist along the wire and x is the deflection of spring under the action of load W along the axis of the coil, so that

$$x = D / 2 \cdot q$$

again $l = p D n$ [consider ,one half turn of a close coiled helical spring]

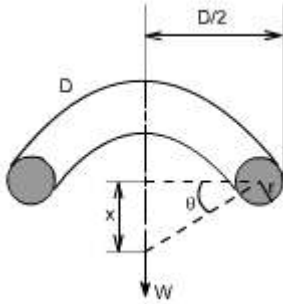

Assumptions: (1) The Bending & shear effects may be neglected

(2) For the purpose of derivation of formula, the helix angle is considered to be so small that it may be neglected.

Any one coil of a such a spring will be assumed to lie in a plane which is nearly \perp to the axis of the spring. This requires that adjoining coils be close together. With this limitation, a section taken perpendicular to the axis the spring rod becomes nearly vertical. Hence to maintain equilibrium of a segment of the spring, only a shearing force $V = F$ and Torque $T = F \cdot r$ are required at any X – section. In the analysis of springs it is customary to assume that the shearing stresses caused by the direct shear force is uniformly distributed and is negligible

so applying the torsion formula.

Using the torsion formula i.e

$$\frac{T}{J} = \frac{\tau}{r} = \frac{G \cdot \theta}{l}$$

and substituting $J = \frac{\pi d^4}{32}$; $T = w \cdot \frac{d}{2}$

$$\theta = \frac{2 \cdot x}{D}; l = \pi D \cdot x$$

SPRING DEFLECTION

$$\frac{w \cdot d / 2}{\frac{\pi d^4}{32}} = \frac{G \cdot 2x / D}{\pi D \cdot x}$$

Thus,

$$x = \frac{8w \cdot D^3 \cdot n}{G \cdot d^4}$$

Spring stiffness: The stiffness is defined as the load per unit deflection therefore

$$k = \frac{w}{x} = \frac{w}{\frac{8wD^3 \cdot n}{G \cdot d^4}}$$

Therefore

$$k = \frac{G \cdot d^4}{8 \cdot D^3 \cdot n}$$

Shear stress

$$\frac{w \cdot d/2}{\frac{\pi d^4}{32}} = \frac{\tau_{\max}}{d/2}$$

$$\text{or } \tau_{\max} = \frac{8wD}{\pi d^3}$$

WAHL'S FACTOR :

In order to take into account the effect of direct shear and change in coil curvature a stress factor is defined, which is known as Wahl's factor

$$K = \text{Wahl's factor and is defined as } K = \frac{4c - 1}{4c - 4} + \frac{0.615}{c}$$

Where C = spring index

$$= D/d$$

if we take into account the Wahl's factor than the formula for the shear stress becomes

$$\tau_{\max} = \frac{16 \cdot T \cdot k}{\pi d^3}$$

Strain Energy : The strain energy is defined as the energy which is stored within a material when the work has been done on the material.

In the case of a spring the strain energy would be due to bending and the strain energy due to bending is given by the expansion

$$U = \frac{T^2 L}{2EI}$$

$$L = \pi D n$$

$$I = \frac{\pi d^4}{64}$$

so after substitution we get

$$U = \frac{32 T^2 D n}{E \cdot d^4}$$

Example: A close coiled helical spring is to carry a load of 5000N with a deflection of 50 mm and a maximum shearing stress of 400 N/mm² .if the number of active turns or active coils is 8.Estimate the following:

(i) wire diameter

(ii) mean coil diameter

(iii) weight of the spring.

Assume $G = 83,000 \text{ N/mm}^2$; $r = 7700 \text{ kg/m}^3$

solution :

(i) for wire diameter if W is the axial load, then

$$\frac{w \cdot d/2}{\frac{\pi d^4}{32}} = \frac{\tau_{\max}}{d/2}$$

$$D = \frac{400 \cdot \pi d^4 \cdot 2}{d/2 \cdot 32 \cdot W}$$

$$D = \frac{400 \cdot \pi d^3 \cdot 2}{5000 \cdot 16}$$

$$D = 0.0314 d^3$$

Further, deflection is given as

$$x = \frac{8wD^3 \cdot n}{G \cdot d^4}$$

on substituting the relevant parameters we get

$$50 = \frac{8 \cdot 5000 \cdot (0.0314 d^3)^3 \cdot 8}{83,000 \cdot d^4}$$

$$d = 13.32 \text{ mm}$$

Therefore,

$$D = 0.0314 \times (13.317)^3 \text{ mm}$$

$$= 74.15 \text{ mm}$$

$$D = 74.15 \text{ mm}$$

Weight

$$\begin{aligned} \text{mass or weight} &= \text{volume} \cdot \text{density} \\ &= \text{area} \cdot \text{length of the spring} \cdot \text{density of spring material} \\ &= \frac{\pi d^2}{4} \cdot \pi D n \cdot \rho \end{aligned}$$

On substituting the relevant parameters we get

$$\begin{aligned} \text{Weight} &= 1.996 \text{ kg} \\ &= 2.0 \text{ kg} \end{aligned}$$

Close – coiled helical spring subjected to axial torque T or axial couple.

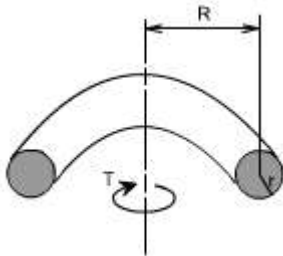

In this case the material of the spring is subjected to pure bending which tends to reduce Radius R of the coils. In this case the bending moment is constant through out the spring and is equal to the applied axial Torque T. The stresses i.e. maximum bending stress may

$$\begin{aligned} \sigma_{\max} &= \frac{M \cdot y}{I} \\ &= \frac{T \cdot d/2}{\frac{\pi d^4}{64}} \\ \sigma_{\max} &= \frac{32T}{\pi d^3} \end{aligned}$$

thus be determined from the bending theory.

Deflection or wind – up angle:

Under the action of an axial torque the deflection of the spring becomes the “wind – up” angle of the spring which is the angle through which one end turns relative to the other. This will be equal to the total change of slope along the wire, according to area – moment theorem

$$\theta = \int_0^L \frac{MdL}{EI} \text{ but } M = T$$

$$= \int_0^L \frac{T \cdot dL}{EI} = \frac{T}{EI} \int_0^L dL$$

Thus, as 'T' remains constant

$$\theta = \frac{T \cdot L}{EI}$$

Further

$$L = \pi D \cdot n$$

$$I = \frac{\pi d^4}{64}$$

Therefore, on substitution, the value of θ obtained is

$$\theta = \frac{64TD \cdot n}{E \cdot d^4}$$

Springs in Series: If two springs of different stiffness are joined end on and carry a common load W , they are said to be connected in series and the combined stiffness and deflection are given by the following equation.

$$\frac{W}{k} = x_1 + x_2 = \frac{W}{k_1} + \frac{W}{k_2}$$

or

$$\frac{1}{k} = \frac{1}{k_1} + \frac{1}{k_2}$$



Springs in parallel: If the two spring are joined in such a way that they have a common deflection 'x'; then they are said to be connected in parallel. In this case the load carried is shared between the two springs and total load $W = W_1 + W_2$

$$x = \frac{W}{k} = \frac{W_1}{k_1} = \frac{W_2}{k_2}$$

$$\text{Thus } W_1 = \frac{Wk_1}{k}$$

$$W_2 = \frac{Wk_2}{k}$$

Further

$$W = W_1 + W_2$$

$$\text{thus } k = k_1 + k_2$$

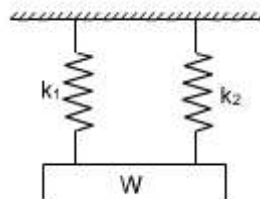

LECTURE 21

Members Subjected to Flexural Loads

Introduction:

In many engineering structures members are required to resist forces that are applied laterally or transversely to their axes. These type of members are termed as beam.

There are various ways to define the beams such as

Definition I: A beam is a laterally loaded member, whose cross-sectional dimensions are small as compared to its length.

Definition II: A beam is nothing simply a bar which is subjected to forces or couples that lie in a plane containing the longitudinal axis of the bar. The forces are understood to act perpendicular to the longitudinal axis of the bar.

Definition III: A bar working under bending is generally termed as a beam.

Materials for Beam:

The beams may be made from several usable engineering materials such commonly among them are as follows:

- Metal
- Wood
- Concrete
- Plastic

Examples of Beams:

Refer to the figures shown below that illustrates the beam

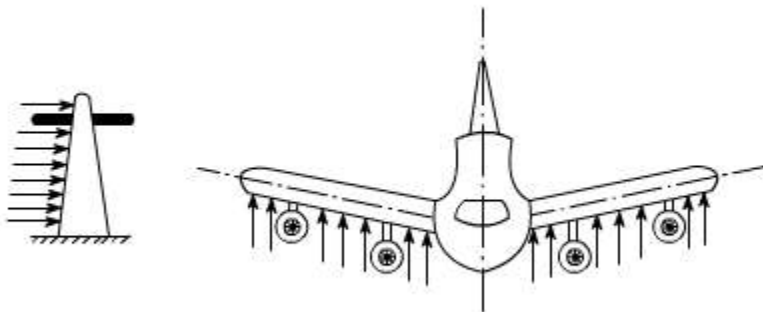

Fig 1

In the fig.1, an electric pole has been shown which is subject to forces occurring due to wind; hence it is an example of beam.

Fig 2

In the fig.2, the wings of an aeroplane may be regarded as a beam because here the aerodynamic action is responsible to provide lateral loading on the member.

Geometric forms of Beams:

The Area of X-section of the beam may take several forms some of them have been shown below:

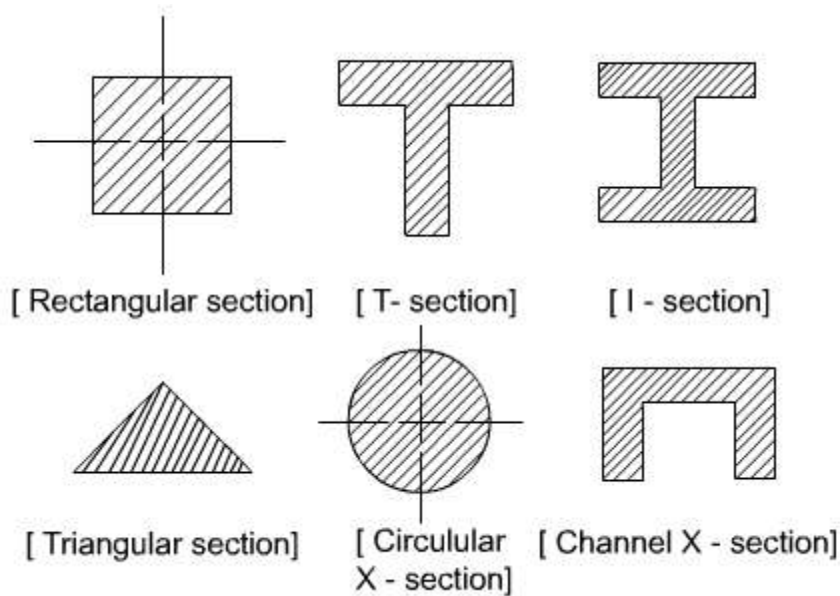

Issues Regarding Beam:

Designer would be interested to know the answers to following issues while dealing with beams in practical engineering application

- At what load will it fail
- How much deflection occurs under the application of loads.

Classification of Beams:

Beams are classified on the basis of their geometry and the manner in which they are supported.

Classification I: The classification based on the basis of geometry normally includes features such as the shape of the X-section and whether the beam is straight or curved.

Classification II: Beams are classified into several groups, depending primarily on the kind of supports used. But it must be clearly understood why do we need supports. The supports are required to provide constraint to the movement of the beams or simply the supports resist the movements either in particular direction or in rotational direction or both. As a consequence of this, the reaction comes into picture whereas to resist rotational movements the moment comes into picture. On the basis of the support, the beams may be classified as follows:

Cantilever Beam: A beam which is supported on the fixed support is termed as a cantilever beam: Now let us understand the meaning of a fixed support. Such a support is obtained by building a beam into a brick wall, casting it into concrete or welding the end of the beam. Such a support provides both the translational and rotational constraint to the beam, therefore the reaction as well as the moments appears, as shown in the figure below

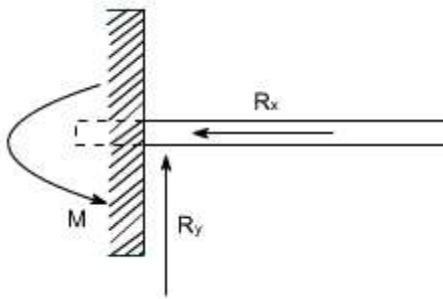

Simply Supported Beam: The beams are said to be simply supported if their supports create only the translational constraints.

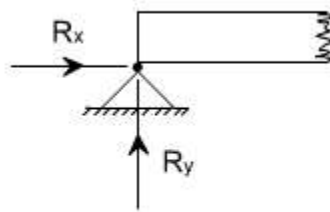
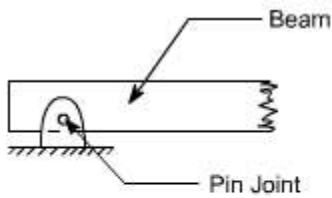

(a) Actual Representation

(b) Diagrammatic Representation

Some times the translational movement may be allowed in one direction with the help of rollers and can be represented like this

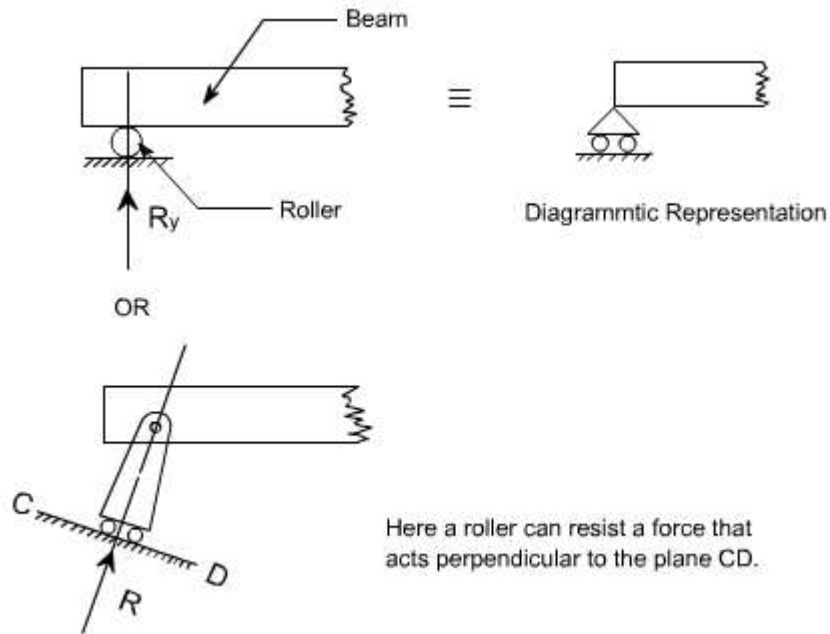

Statically Determinate or Statically Indeterminate Beams:

The beams can also be categorized as statically determinate or else it can be referred as statically indeterminate. If all the external forces and moments acting on it can be determined from the equilibrium conditions alone then. It would be referred as a statically determinate beam, whereas in the statically indeterminate beams one has to consider deformation i.e. deflections to solve the problem.

Types of loads acting on beams:

A beam is normally horizontal where as the external loads acting on the beams is generally in the vertical directions. In order to study the behaviors of beams under flexural loads. It becomes pertinent that one must be familiar with the various types of loads acting on the beams as well as their physical manifestations.

A. Concentrated Load: It is a kind of load which is considered to act at a point. By this we mean that the length of beam over which the force acts is so small in comparison to its total length that one can model the force as though applied at a point in two dimensional view of beam. Here in this case, force or load may be made to act on a beam by a hanger or through other means

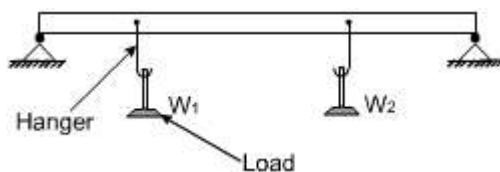

B. Distributed Load: The distributed load is a kind of load which is made to spread over a entire span of beam or over a particular portion of the beam in some specific manner

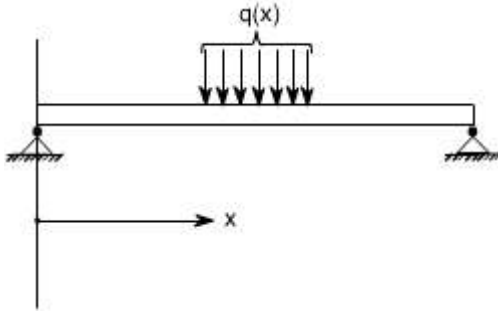

In the above figure, the rate of loading 'q' is a function of x i.e. span of the beam, hence this is a non uniformly distributed load.

The rate of loading 'q' over the length of the beam may be uniform over the entire span of beam, then we call this as a uniformly distributed load (U.D.L). The U.D.L may be represented in either of the way on the beams

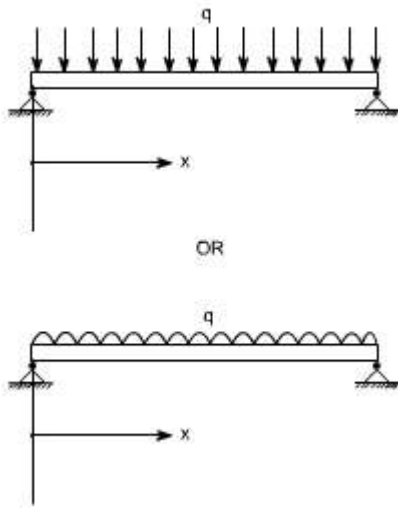

some times the load acting on the beams may be the uniformly varying as in the case of dams or on inclind wall of a vessel containing liquid, then this may be represented on the beam as below:

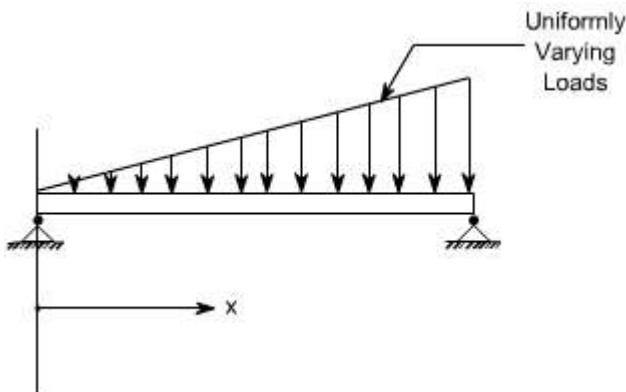

The U.D.L can be easily realized by making idealization of the ware house load, where the bags of grains are placed over a beam.

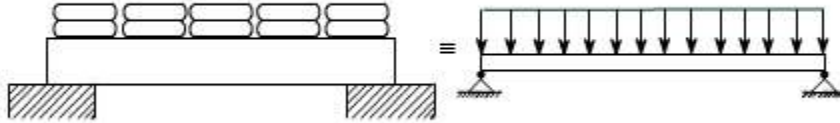

Concentrated Moment:

The beam may be subjected to a concentrated moment essentially at a point. One of the possible arrangement for applying the moment is being shown in the figure below:

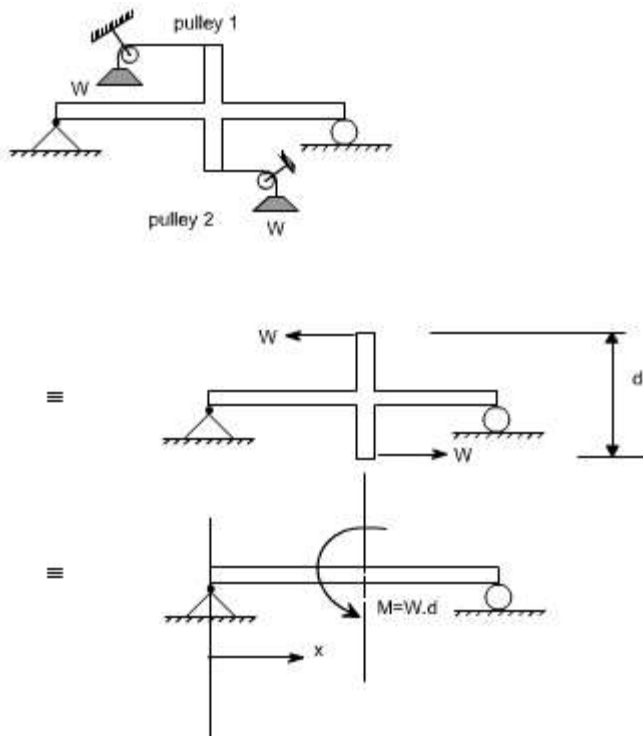

LECTURE 22

Concept of Shear Force and Bending moment in beams:

When the beam is loaded in some arbitrarily manner, the internal forces and moments are developed and the terms shear force and bending moments come into pictures which are helpful to analyze the beams further. Let us define these terms

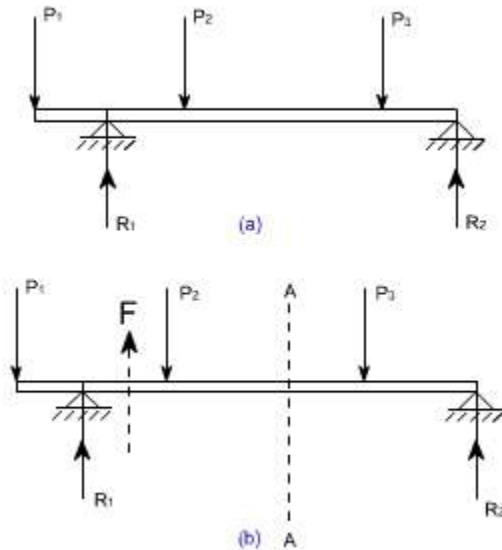

Fig 1

Now let us consider the beam as shown in fig 1(a) which is supporting the loads P_1 , P_2 , P_3 and is simply supported at two points creating the reactions R_1 and R_2 respectively. Now let us assume that the beam is to be divided into or imagined to be cut into two portions at a section AA. Now let us assume that the resultant of loads and reactions to the left of AA is 'F' vertically upwards, and since the entire beam is to remain in equilibrium, thus the resultant of forces to the right of AA must also be F, acting downwards. This force 'F' is as a shear force. The shearing force at any x-section of a beam represents the tendency for the portion of the beam to one side of the section to slide or shear laterally relative to the other portion.

Therefore, now we are in a position to define the shear force 'F' to as follows:

At any x-section of a beam, the shear force 'F' is the algebraic sum of all the lateral components of the forces acting on either side of the x-section.

Sign Convention for Shear Force:

The usual sign conventions to be followed for the shear forces have been illustrated in figures 2 and 3.

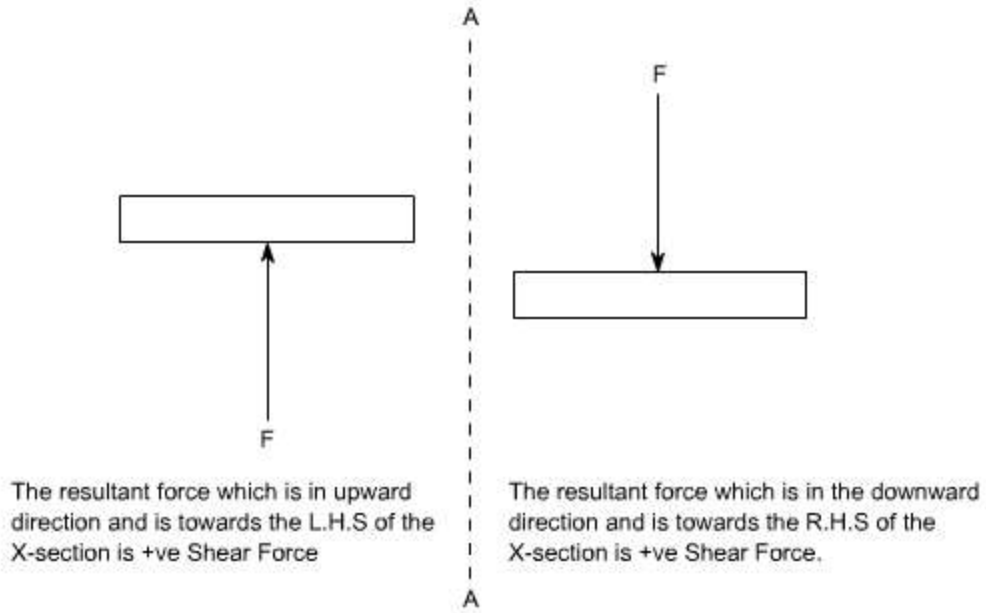

Fig 2: Positive Shear Force

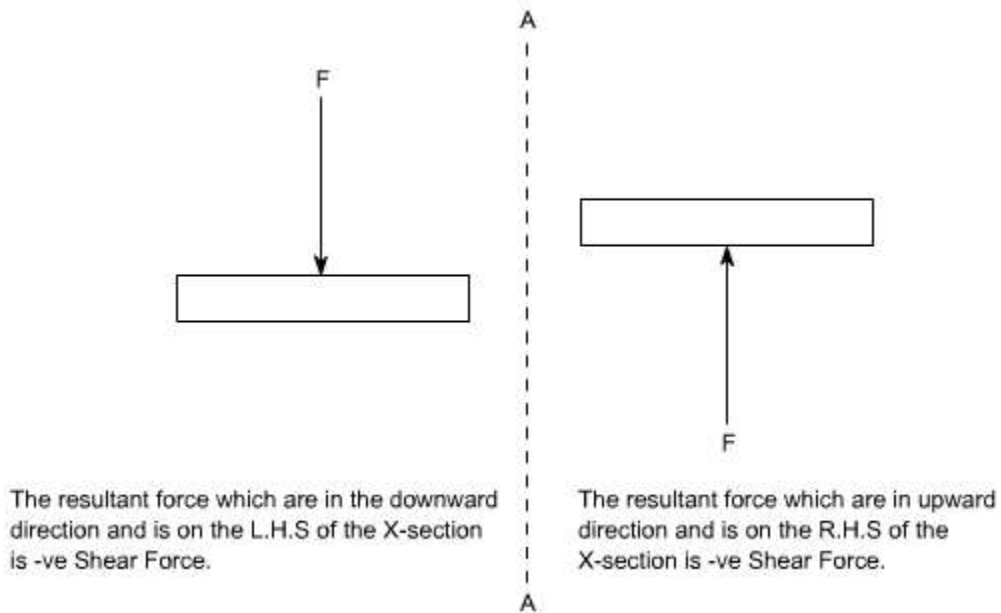

Fig 3: Negative Shear Force

Bending Moment:

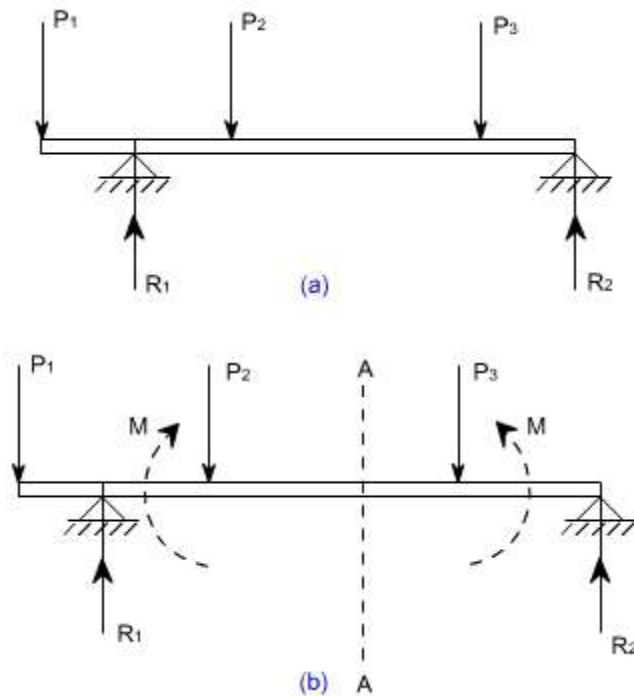

Fig 4

Let us again consider the beam which is simply supported at the two prints, carrying loads P_1 , P_2 and P_3 and having the reactions R_1 and R_2 at the supports Fig 4. Now, let us imagine that the beam is cut into two potions at the x-section AA. In a similar manner, as done for the case of shear force, if we say that the resultant moment about the section AA of all the loads and reactions to the left of the x-section at AA is M in C.W direction, then moment of forces to the right of x-section AA must be ' M ' in C.C.W. Then ' M ' is called as the Bending moment and is abbreviated as B.M. Now one can define the bending moment to be simply as the algebraic sum of the moments about an x-section of all the forces acting on either side of the section

Sign Conventions for the Bending Moment:

For the bending moment, following sign conventions may be adopted as indicated in Fig 5 and Fig 6.

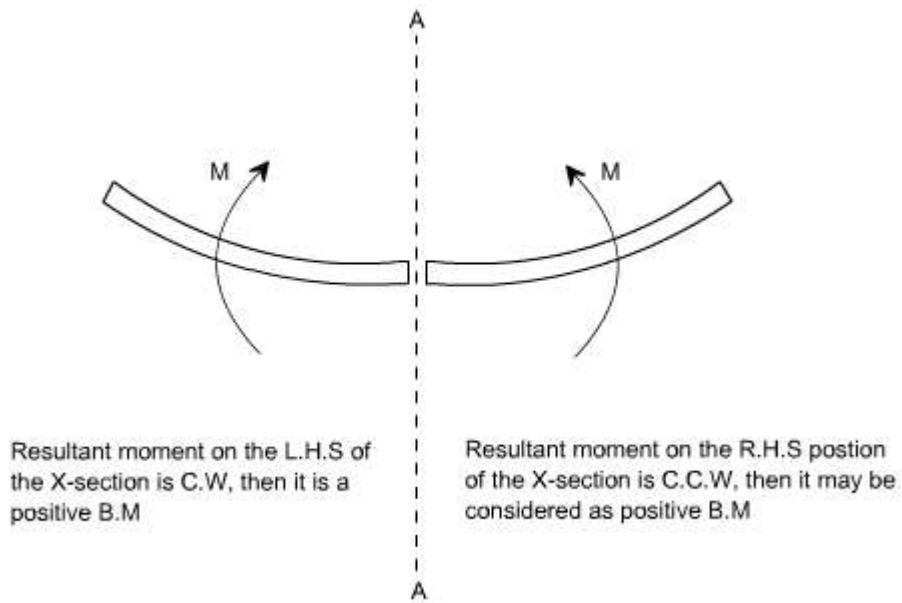

Fig 5: Positive Bending Moment

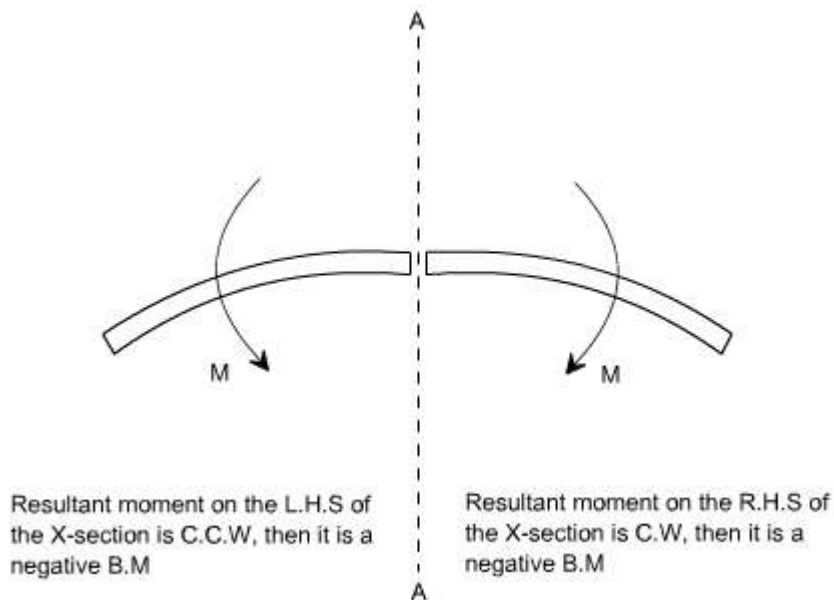

Fig 6: Negative Bending Moment

Some times, the terms 'Sagging' and Hogging are generally used for the positive and negative bending moments respectively.

Bending Moment and Shear Force Diagrams:

The diagrams which illustrate the variations in B.M and S.F values along the length of

the beam for any fixed loading conditions would be helpful to analyze the beam further.

Thus, a shear force diagram is a graphical plot, which depicts how the internal shear force 'F' varies along the length of beam. If x denotes the length of the beam, then F is function x i.e. $F(x)$.

Similarly a bending moment diagram is a graphical plot which depicts how the internal bending moment 'M' varies along the length of the beam. Again M is a function x i.e. $M(x)$.

Basic Relationship Between The Rate of Loading, Shear Force and Bending Moment:

The construction of the shear force diagram and bending moment diagrams is greatly simplified if the relationship among load, shear force and bending moment is established.

Let us consider a simply supported beam AB carrying a uniformly distributed load w/length . Let us imagine to cut a short slice of length dx cut out from this loaded beam at distance ' x ' from the origin 'O'.

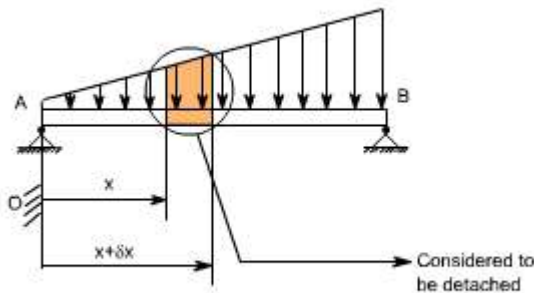

Let us detach this portion of the beam and draw its free body diagram.

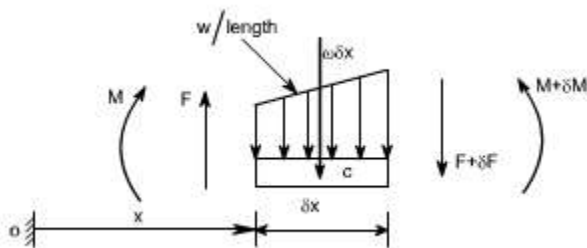

The forces acting on the free body diagram of the detached portion of this loaded beam are the following

- The shearing force F and $F + dF$ at the section x and $x + dx$ respectively.

- The bending moment at the sections x and $x + dx$ be M and $M + dM$ respectively.
- Force due to external loading, if 'w' is the mean rate of loading per unit length then the total loading on this slice of length dx is $w \cdot dx$, which is approximately acting through the centre 'c'. If the loading is assumed to be uniformly distributed then it would pass exactly through the centre 'c'.

This small element must be in equilibrium under the action of these forces and couples.

Now let us take the moments at the point 'c'. Such that

$$M + F \cdot \frac{\delta x}{2} + (F + \delta F) \cdot \frac{\delta x}{2} = M + \delta M$$

$$\Rightarrow F \cdot \frac{\delta x}{2} + (F + \delta F) \cdot \frac{\delta x}{2} = \delta M$$

$$\Rightarrow F \cdot \frac{\delta x}{2} + F \cdot \frac{\delta x}{2} + \delta F \cdot \frac{\delta x}{2} = \delta M \text{ [Neglecting the product of } \delta F \text{ and } \delta x \text{ being small quantities]}$$

$$\Rightarrow F \cdot \delta x = \delta M$$

$$\Rightarrow F = \frac{\delta M}{\delta x}$$

Under the limits $\delta x \rightarrow 0$

$$\boxed{F = \frac{dM}{dx}} \quad \dots\dots\dots (1)$$

Re solving the forces vertically we get

$$w \cdot \delta x + (F + \delta F) = F$$

$$\Rightarrow w = - \frac{\delta F}{\delta x}$$

Under the limits $\delta x \rightarrow 0$

$$\Rightarrow w = - \frac{dF}{dx} \text{ or } - \frac{d}{dx} \left(\frac{dM}{dx} \right)$$

$$\boxed{w = - \frac{dF}{dx} = - \frac{d^2M}{dx^2}} \quad \dots\dots\dots (2)$$

Conclusions: From the above relations, the following important conclusions may be drawn

- From Equation (1), the area of the shear force diagram between any two points, from the basic calculus is the bending moment diagram

$$M = \int F \cdot dx$$

- The slope of bending moment diagram is the shear force, thus

$$F = \frac{dM}{dx}$$

Thus, if $F=0$; the slope of the bending moment diagram is zero and the bending moment is therefore constant.'

- The maximum or minimum Bending moment occurs where $\frac{dM}{dx} = 0$.

The slope of the shear force diagram is equal to the magnitude of the intensity of the distributed loading at any position along the beam. The -ve sign is as a consequence of our particular choice of sign conventions

LECTURE 23 and 24

Procedure for drawing shear force and bending moment diagram:

Preamble:

The advantage of plotting a variation of shear force F and bending moment M in a beam as a function of 'x' measured from one end of the beam is that it becomes easier to determine the maximum absolute value of shear force and bending moment.

Further, the determination of value of M as a function of 'x' becomes of paramount importance so as to determine the value of deflection of beam subjected to a given loading.

Construction of shear force and bending moment diagrams:

A shear force diagram can be constructed from the loading diagram of the beam. In order to draw this, first the reactions must be determined always. Then the vertical components of forces and reactions are successively summed from the left end of the beam to preserve the mathematical sign conventions adopted. The shear at a section is simply equal to the sum of all the vertical forces to the left of the section.

When the successive summation process is used, the shear force diagram should end up with the previously calculated shear (reaction at right end of the beam. No shear force acts through the beam just beyond the last vertical force or reaction. If the shear force diagram closes in this fashion, then it gives an important check on mathematical calculations.

The bending moment diagram is obtained by proceeding continuously along the length of beam from the left hand end and summing up the areas of shear force diagrams giving due regard to sign. The process of obtaining the moment diagram from the shear force

diagram by summation is exactly the same as that for drawing shear force diagram from load diagram.

It may also be observed that a constant shear force produces a uniform change in the bending moment, resulting in straight line in the moment diagram. If no shear force exists along a certain portion of a beam, then it indicates that there is no change in moment takes place. It may also further observe that $dm/dx = F$ therefore, from the fundamental theorem of calculus the maximum or minimum moment occurs where the shear is zero. In order to check the validity of the bending moment diagram, the terminal conditions for the moment must be satisfied. If the end is free or pinned, the computed sum must be equal to zero. If the end is built in, the moment computed by the summation must be equal to the one calculated initially for the reaction. These conditions must always be satisfied.

Illustrative problems:

In the following sections some illustrative problems have been discussed so as to illustrate the procedure for drawing the shear force and bending moment diagrams

1. A cantilever of length carries a concentrated load 'W' at its free end.

Draw shear force and bending moment.

Solution:

At a section a distance x from free end consider the forces to the left, then $F = -W$ (for all values of x) -ve sign means the shear force to the left of the x -section are in downward direction and therefore negative

Taking moments about the section gives (obviously to the left of the section)

$M = -Wx$ (-ve sign means that the moment on the left hand side of the portion is in the anticlockwise direction and is therefore taken as -ve according to the sign convention)

so that the maximum bending moment occurs at the fixed end i.e. $M = -Wl$

From equilibrium consideration, the fixing moment applied at the fixed end is Wl and the reaction is W . the shear force and bending moment are shown as,

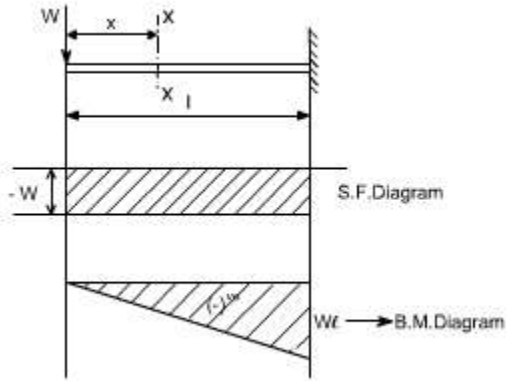

2. Simply supported beam subjected to a central load (i.e. load acting at the mid-way)

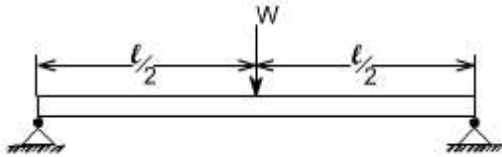

By symmetry the reactions at the two supports would be $W/2$ and $W/2$. now consider any section X-X from the left end then, the beam is under the action of following forces.

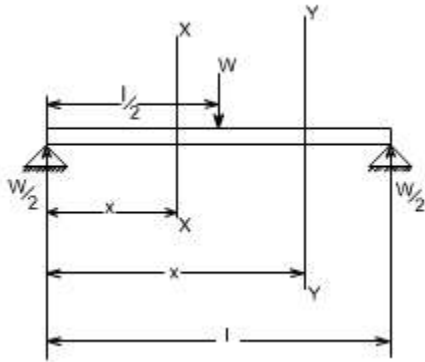

.So the shear force at any X-section would be = $W/2$ [Which is constant upto $x < l/2$]

If we consider another section Y-Y which is beyond $l/2$ then

$$S.F_{Y-Y} = \frac{W}{2} - W = \frac{-W}{2} \text{ for all values greater } = l/2$$

Hence S.F diagram can be plotted as,

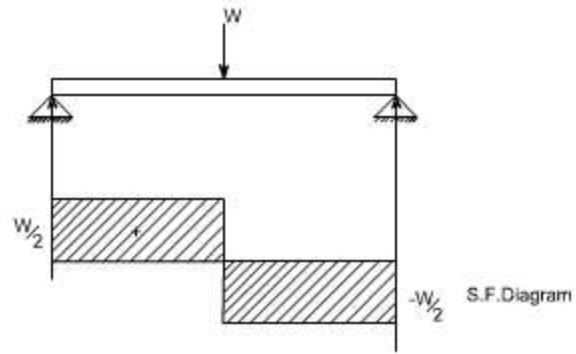

.For B.M diagram:

If we just take the moments to the left of the cross-section,

$$B.M_{x-x} = \frac{W}{2} x \text{ for } x \text{ lies between } 0 \text{ and } l/2$$

$$B.M_{\text{at } x = \frac{l}{2}} = \frac{W}{2} \cdot \frac{l}{2} \text{ i.e. B.M at } x = 0$$

$$= \frac{Wl}{4}$$

$$B.M_{Y-Y} = \frac{W}{2} x - W \left(x - \frac{l}{2} \right)$$

Again

$$= \frac{W}{2} x - Wx + \frac{Wl}{2}$$

$$= -\frac{W}{2} x + \frac{Wl}{2}$$

$$B.M_{\text{at } x = l} = -\frac{Wl}{2} + \frac{Wl}{2}$$

$$= 0$$

Which when plotted will give a straight relation i.e.

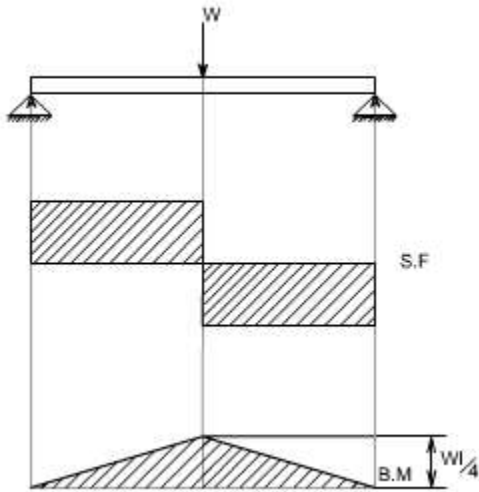

It may be observed that at the point of application of load there is an abrupt change in the shear force, at this point the B.M is maximum.

3. A cantilever beam subjected to U.d.L, draw S.F and B.M diagram.

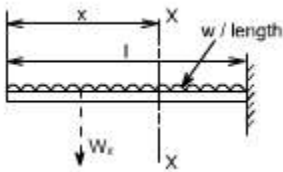

Here the cantilever beam is subjected to a uniformly distributed load whose intensity is given w / length .

Consider any cross-section XX which is at a distance of x from the free end. If we just take the resultant of all the forces on the left of the X-section, then

$$S.F_{xx} = -Wx \text{ for all values of 'x'. ----- (1)}$$

$$S.F_{xx} = 0$$

$$S.F_{xx \text{ at } x=l} = -Wl$$

So if we just plot the equation No. (1), then it will give a straight line relation. Bending Moment at X-X is obtained by treating the load to the left of X-X as a concentrated load of the same value acting through the centre of gravity.

Therefore, the bending moment at any cross-section X-X is

$$\begin{aligned}
 \text{B.M}_{x-x} &= - W x \frac{x}{2} \\
 &= - W \frac{x^2}{2}
 \end{aligned}$$

The above equation is a quadratic in x , when B.M is plotted against x this will produce a parabolic variation.

The extreme values of this would be at $x = 0$ and $x = l$

$$\begin{aligned}
 \text{B.M}_{\text{at } x=l} &= - \frac{Wl^2}{2} \\
 &= \frac{Wl}{2} - Wx
 \end{aligned}$$

Hence S.F and B.M diagram can be plotted as follows:

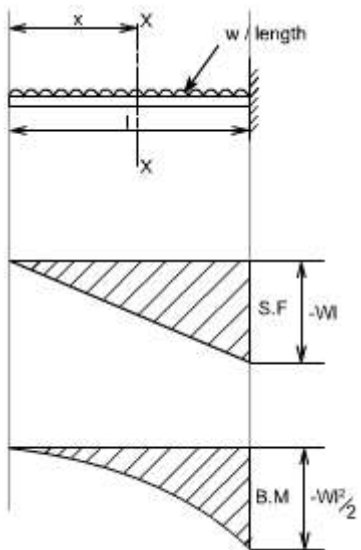

4. Simply supported beam subjected to a uniformly distributed load [U.D.L].

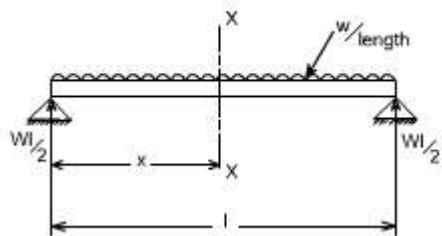

The total load carried by the span would be

= intensity of loading x length

$$= w \times l$$

By symmetry the reactions at the end supports are each $wl/2$

If x is the distance of the section considered from the left hand end of the beam.

S.F at any X-section X-X is

$$= \frac{wl}{2} - wx$$
$$= w \left(\frac{l}{2} - x \right)$$

Giving a straight relation, having a slope equal to the rate of loading or intensity of the loading.

$$\text{S.F. at } x=0 = \frac{wl}{2} - wx$$

so at

$$\text{S.F. at } x = \frac{l}{2} = 0 \text{ hence the S.F is zero at the centre}$$

$$\text{S.F. at } x=l = -\frac{wl}{2}$$

The bending moment at the section x is found by treating the distributed load as acting at its centre of gravity, which is at a distance of $x/2$ from the section

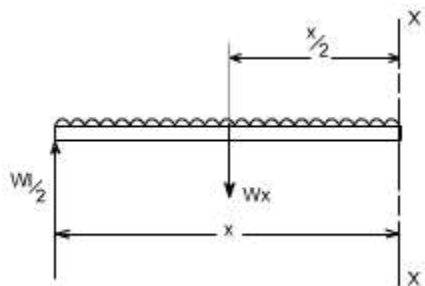

$$B.M_{x-x} = \frac{Wl}{2}x - Wx \cdot \frac{x}{2}$$

so the

$$= W \cdot \frac{x}{2} (l - x) \dots\dots (2)$$

$$B.M_{\text{at } x=0} = 0$$

$$B.M_{\text{at } x=l} = 0$$

$$B.M \Big|_{\text{at } x=l} = -\frac{Wl^2}{8}$$

So the equation (2) when plotted against x gives rise to a parabolic curve and the shear force and bending moment can be drawn in the following way will appear as follows:

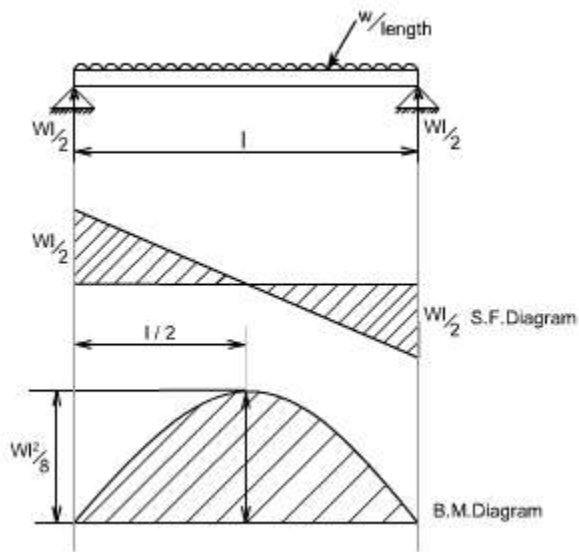

5. Couple.

When the beam is subjected to couple, the shear force and Bending moment diagrams may be drawn exactly in the same fashion as discussed earlier.

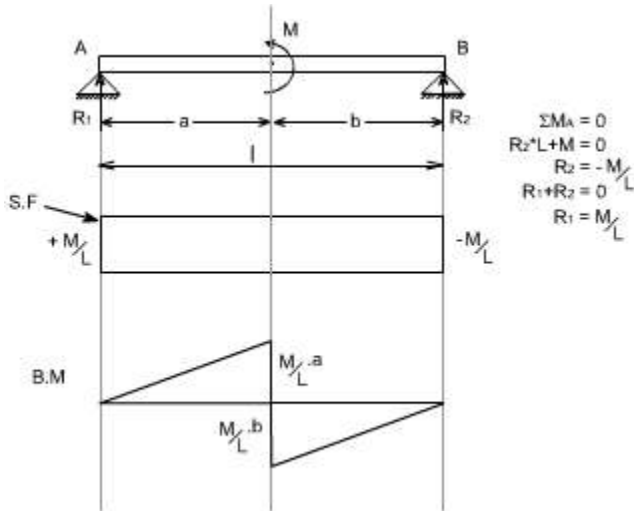

6. Eccentric loads.

When the beam is subjected to an eccentric load, the eccentric load is to be changed into a couple/force as the case may be. In the illustrative example given below, the 20 kN load acting at a distance of 0.2m may be converted to an equivalent of 20 kN force and a couple of 2 kN.m. Similarly a 10 kN force which is acting at an angle of 30° may be resolved into horizontal and vertical components. The rest of the procedure for drawing the shear force and Bending moment diagrams remains the same.

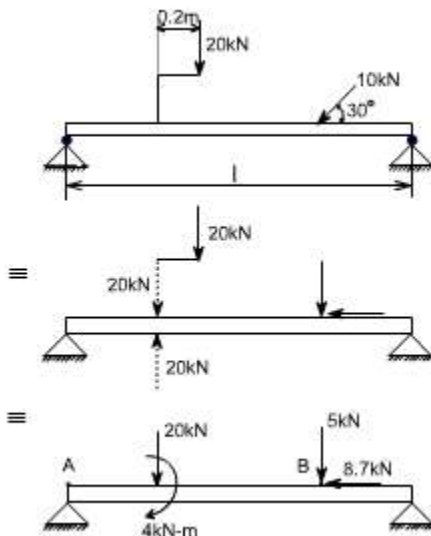

6. Loading changes or there is an abrupt change of loading:

When there is an abrupt change of loading or loads change, the problem may be tackled in a systematic way. Consider a cantilever beam of 3 meters length. It carries a uniformly distributed load of 2 kN/m and a concentrated load of 2kN at the free end and 4kN at 2 meters from the fixed end. The shearing force and bending moment diagrams are required to

be drawn and state the maximum values of the shearing force and bending moment.

Solution

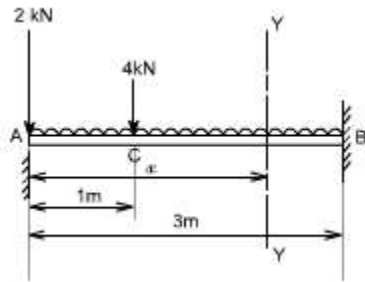

Consider any cross section x-x, at a distance x from the free end

$$\text{Shear Force at } x-x = -2 - 2x \quad 0 < x < 1$$

$$\text{S.F at } x = 0 \text{ i.e. at A} = -2 \text{ kN}$$

$$\text{S.F at } x = 1 = -2 - 2 = -4 \text{ kN}$$

$$\text{S.F at C (} x = 1) = -2 - 2x - 4 \text{ Concentrated load}$$

$$= -2 - 4 - 2 \times 1 \text{ kN}$$

$$= -8 \text{ kN}$$

Again consider any cross-section YY, located at a distance x from the free end

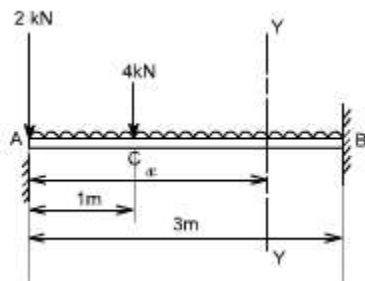

$$\text{S.F at Y-Y} = -2 - 2x - 4 \quad 1 < x < 3$$

This equation again gives S.F at point C equal to -8kN

$$\text{S.F at } x = 3 \text{ m} = -2 - 4 - 2 \times 3$$

$$= -12 \text{ kN}$$

Hence the shear force diagram can be drawn as below:

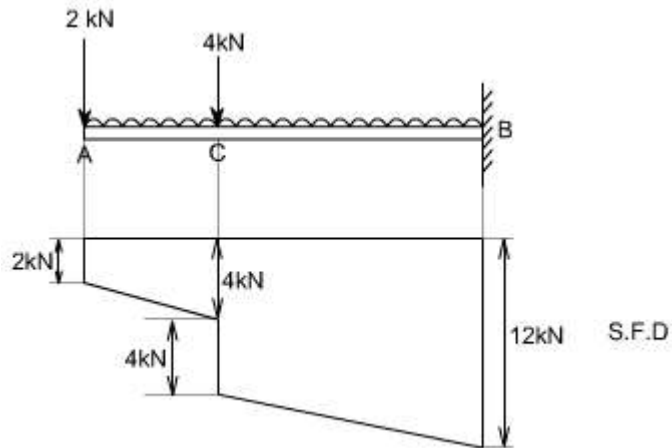

For bending moment diagrams – Again write down the equations for the respective cross sections, as consider above

Bending Moment at $xx = -2x - 2x.x/2$ valid upto AC

B.M at $x = 0 = 0$

B.M at $x = 1\text{m} = -3 \text{ kN.m}$

For the portion CB, the bending moment equation can be written for the x-section at Y-Y

B.M at YY = $-2x - 2x.x/2 - 4(x - 1)$

This equation again gives,

B.M at point C = $- 2.1 - 1 - 0$ i.e. at $x = 1$

= -3 kN.m

B.M at point B i.e. at $x = 3 \text{ m}$

= $- 6 - 9 - 8$

= $- 23 \text{ kN-m}$

The variation of the bending moment diagrams would obviously be a parabolic curve

Hence the bending moment diagram would be

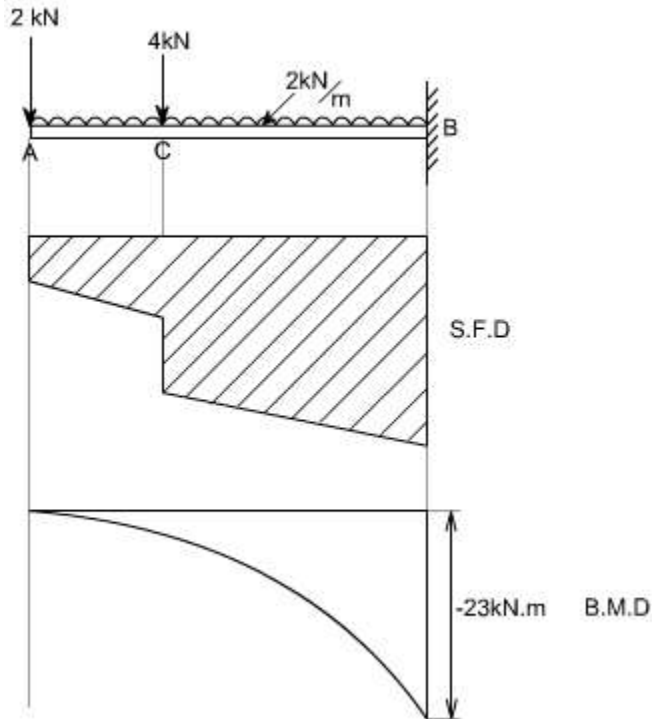

7. Illustrative Example :

In this there is an abrupt change of loading beyond a certain point thus, we shall have to be careful at the jumps and the discontinuities.

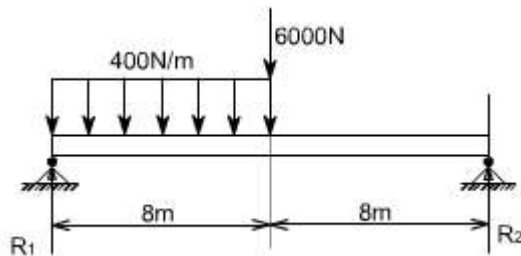

For the given problem, the values of reactions can be determined as

$$R_2 = 3800\text{N and } R_1 = 5400\text{N}$$

The shear force and bending moment diagrams can be drawn by considering the X-sections at the suitable locations.

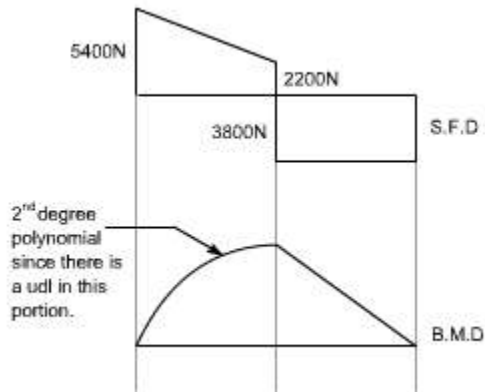

8. Illustrative Problem :

The simply supported beam shown below carries a vertical load that increases uniformly from zero at the one end to the maximum value of 6kN/m of length at the other end .Draw the shearing force and bending moment diagrams.

Solution

Determination of Reactions

For the purpose of determining the reactions R₁ and R₂ , the entire distributed load may be replaced by its resultant which will act through the centroid of the triangular loading diagram.

So the total resultant load can be found like this-

$$\text{Average intensity of loading} = (0 + 6)/2$$

$$= 3 \text{ kN/m}$$

$$\text{Total Load} = 3 \times 12$$

$$= 36 \text{ kN}$$

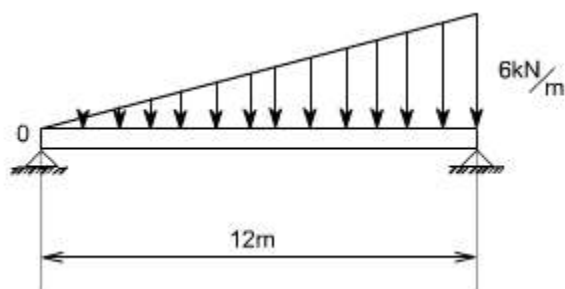

Since the centroid of the triangle is at a 2/3 distance from the one end, hence $2/3 \times 3 = 8$

m from the left end support.

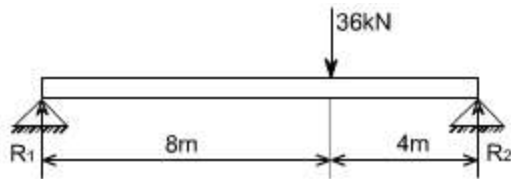

Now taking moments or applying conditions of equilibrium

$$36 \times 8 = R_2 \times 12$$

$$R_1 = 12 \text{ kN}$$

$$R_2 = 24 \text{ kN}$$

Note: however, this resultant can not be used for the purpose of drawing the shear force and bending moment diagrams. We must consider the distributed load and determine the shear and moment at a section x from the left hand end.

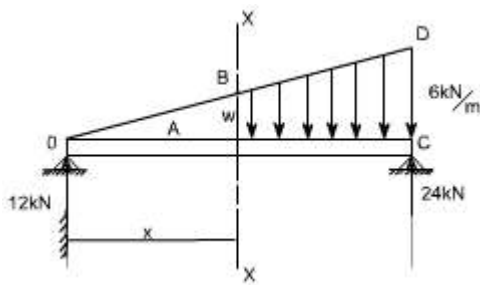

Consider any X-section X-X at a distance x , as the intensity of loading at this X-section, is unknown let us find out the resultant load which is acting on the L.H.S of the X-section X-X, hence

So consider the similar triangles

OAB & OCD

$$\frac{w}{6} = \frac{x}{12}$$

$$w = \frac{x}{2} \text{ k} \frac{\text{N}}{\text{m}}$$

In order to find out the total resultant load on the left hand side of the X-section

Find the average load intensity

$$= \frac{0 + \frac{x}{2}}{2}$$

$$= \frac{x}{4} \text{ k} \frac{\text{N}}{\text{m}}$$

Therefore the total load over the length x would be

$$= \frac{x}{4} \cdot x \text{ kN}$$

$$= \frac{x^2}{4} \text{ kN}$$

Now these loads will act through the centroid of the triangle OAB. i.e. at a distance $\frac{2}{3}x$ from the left hand end. Therefore, the shear force and bending moment equations may be written as

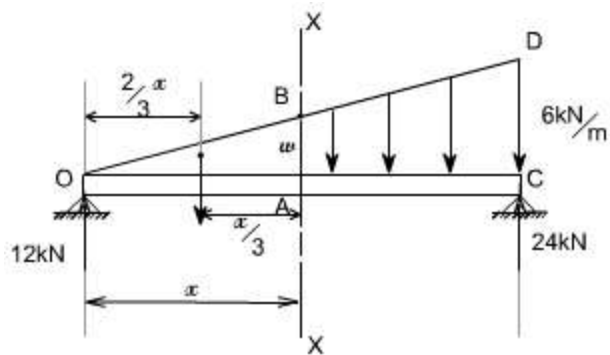

$$S.F_{\text{at } xx} = \left(12 - \frac{x^2}{4}\right) \text{ kN}$$

valid for all values of x(1)

$$B.M_{\text{at } xx} = 12x - \frac{x^2}{4} \cdot \frac{x}{3}$$

$$B.M_{\text{at } xx} = 12x - \frac{x^3}{12} \text{ kN-m}$$

valid for all values of x(2)

$$S.F_{\text{at } x=0} = 12 \text{ kN}$$

$$S.F_{\text{at } x=12\text{m}} = 12 - \frac{12 \times 12}{4}$$

$$= -24 \text{ kN}$$

In order to find out the point where S.F is zero

$$\left(12 - \frac{x^2}{4}\right) = 0$$

$x = 6.92 \text{ m}$ (selecting the positive values)

Again

$$B.M_{\text{at } x=0} = 0$$

$$B.M_{\text{at } x=12} = 12 \times 12 - \frac{12^3}{12}$$

$$= 0$$

$$B.M_{\text{at } x=6.92} = 12 \times 6.92 - \frac{6.92^3}{12}$$

$$= 55.42 \text{ kN-m}$$

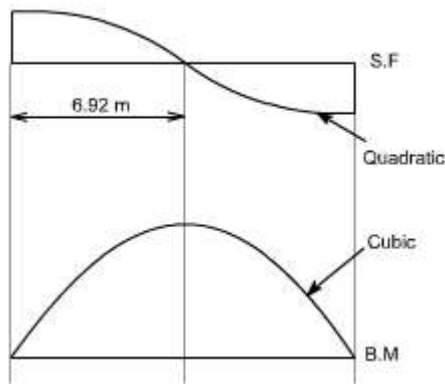

9. Illustrative problem :

In the same way, the shear force and bending moment diagrams may be attempted for the given problem

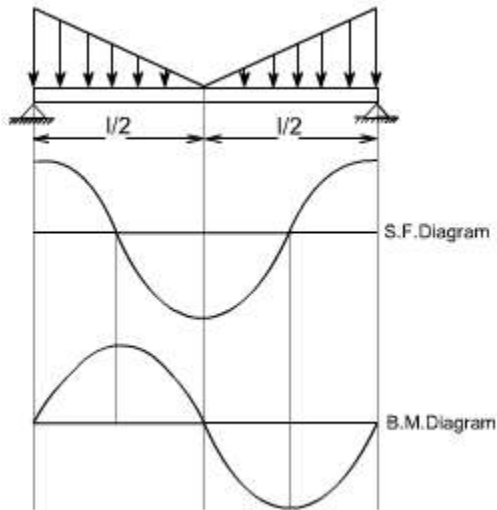

10. Illustrative problem :

For the uniformly varying loads, the problem may be framed in a variety of ways, observe the shear force and bending moment diagrams

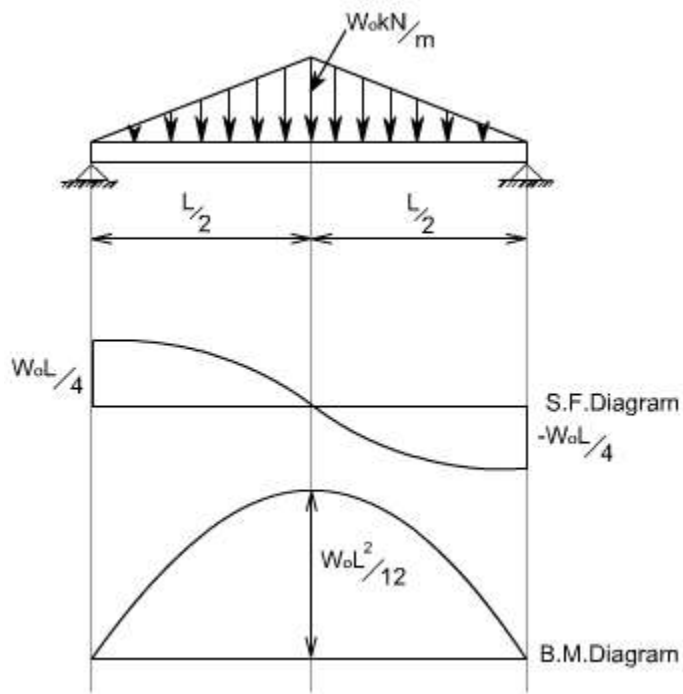

11. Illustrative problem :

In the problem given below, the intensity of loading varies from q_1 kN/m at one end to the q_2 kN/m at the other end. This problem can be treated by considering a U.d.l of intensity q_1 kN/m over the entire span and a uniformly varying load of 0 to $(q_2 - q_1)$ kN/m over the entire span and then super impose the two loadings.

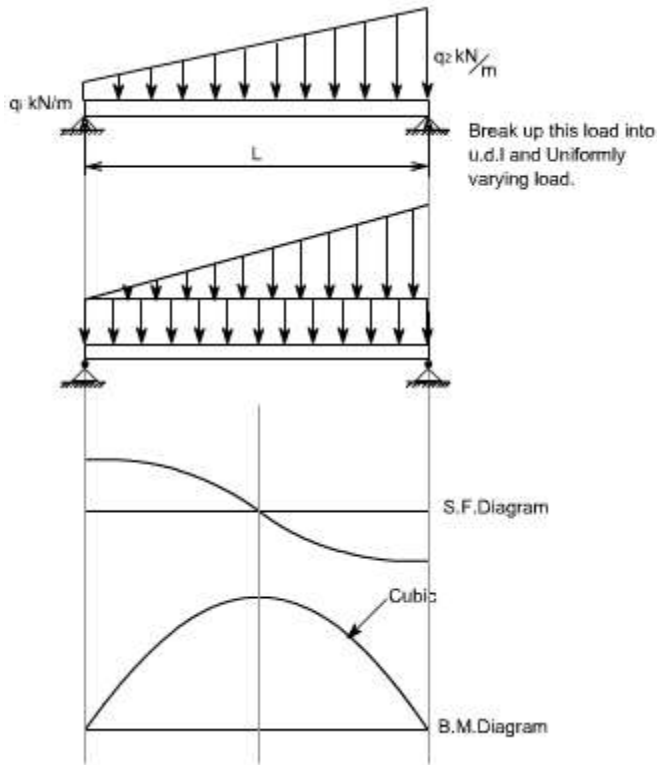

Point of Contraflexure:

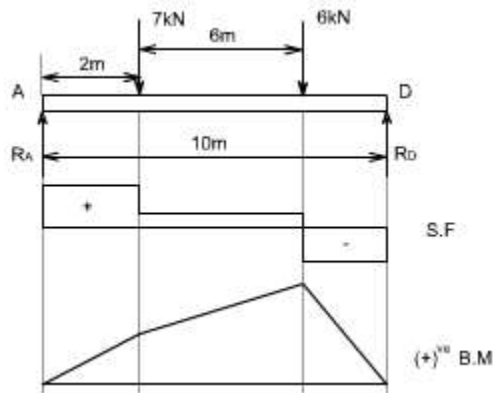

Consider the loaded beam as shown below along with the shear force and Bending moment diagrams for it. It may be observed that in this case, the bending moment diagram is completely positive so that the curvature of the beam varies along its length, but it is always concave upwards or sagging. However, if we consider again a loaded beam as shown below along with the S.F. and B.M. diagrams, then

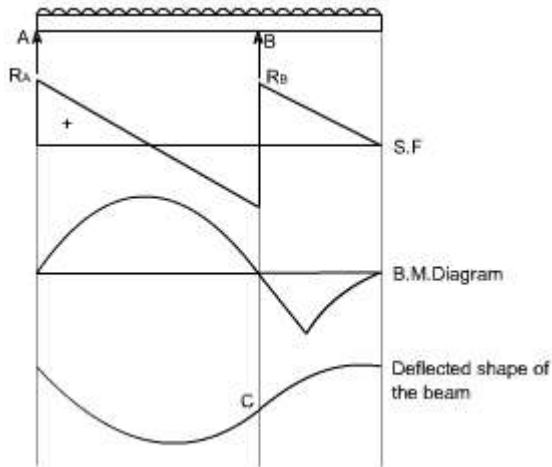

It may be noticed that for the beam loaded as in this case,

The bending moment diagram is partly positive and partly negative. If we plot the deflected shape of the beam just below the bending moment

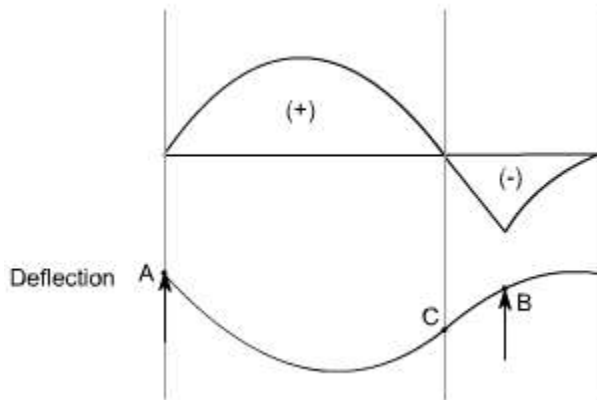

This diagram shows that L.H.S of the beam 'sags' while the R.H.S of the beam 'hogs'

The point C on the beam where the curvature changes from sagging to hogging is a point of contraflexure.

OR

It corresponds to a point where the bending moment changes the sign, hence in order to find the point of contraflexure obviously the B.M would change its sign when it cuts the X-axis therefore to get the points of contraflexure equate the bending moment equation equal to zero. The fibre stress is zero at such sections

Note: there can be more than one point of contraflexure.

LECTURE 25 and 26

Simple Bending Theory OR Theory of Flexure for Initially Straight Beams

(The normal stress due to bending are called flexure stresses)

Preamble:

When a beam having an arbitrary cross section is subjected to a transverse loads the beam will bend. In addition to bending the other effects such as twisting and buckling may occur, and to investigate a problem that includes all the combined effects of bending, twisting and buckling could become a complicated one. Thus we are interested to investigate the bending effects alone, in order to do so, we have to put certain constraints on the geometry of the beam and the manner of loading.

Assumptions:

The constraints put on the geometry would form the **assumptions**:

1. Beam is initially **straight** , and has a **constant cross-section**.
2. Beam is made of **homogeneous material** and the beam has a **longitudinal plane of symmetry**.
3. Resultant of the applied loads lies in the plane of symmetry.
4. The geometry of the overall member is such that bending not buckling is the primary cause of failure.
5. Elastic limit is nowhere exceeded and 'E' is same in tension and compression.
6. Plane cross - sections remains plane before and after bending.

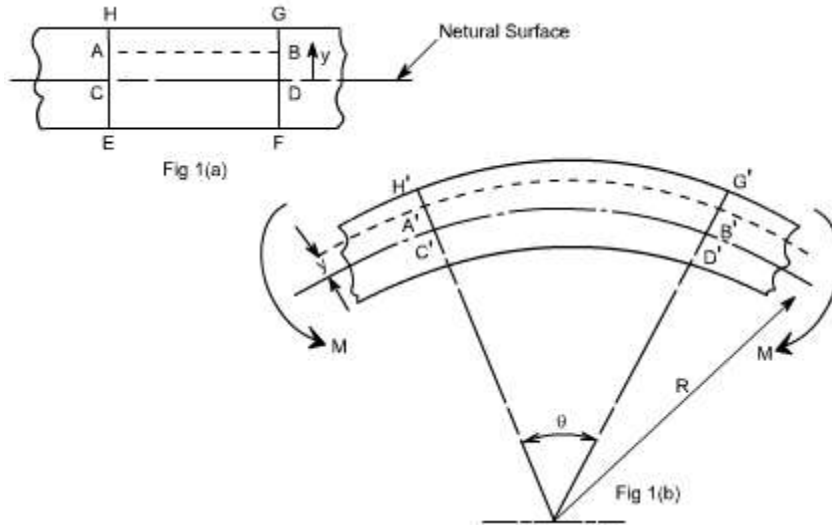

Let us consider a beam initially unstressed as shown in fig 1(a). Now the beam is subjected to a constant bending moment (i.e. 'Zero Shearing Force') along its length as would be obtained by applying equal couples at each end. The beam will bend to the radius R as shown in Fig 1(b)

As a result of this bending, the top fibers of the beam will be subjected to tension and the bottom to compression it is reasonable to suppose, therefore, **that some where between the two there are points at which the stress is zero. The locus of all such points is known as neutral axis** . The radius of curvature R is then measured to this axis. For symmetrical sections the N. A. is the axis of symmetry but what ever the section N. A. will always pass through the centre of the area or centroid.

The above restrictions have been taken so as to eliminate the possibility of 'twisting' of the beam.

Concept of pure bending:

Loading restrictions:

As we are aware of the fact internal reactions developed on any cross-section of a beam may consists of a resultant normal force, a resultant shear force and a resultant couple. In order to ensure that the bending effects alone are investigated, we shall put a constraint on the loading such that the resultant normal and the resultant shear forces are zero on any cross-section perpendicular to the longitudinal axis of the member,

That means $F = 0$

since $\frac{dM}{dx} = F = 0$ or $M = \text{constant}$.

Thus, the zero shear force means that the bending moment is constant or the bending is

same at every cross-section of the beam. Such a situation may be visualized or envisaged when the beam or some portion of the beam, as been loaded only by pure couples at its ends. It must be recalled that the couples are assumed to be loaded in the plane of symmetry.

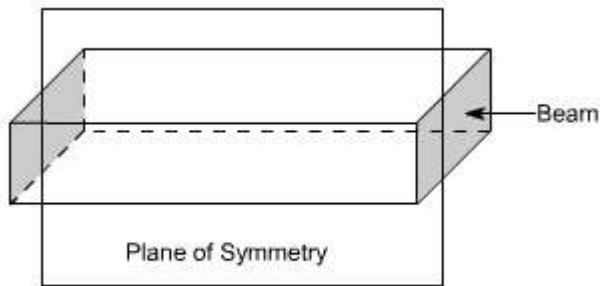

Fig (1)

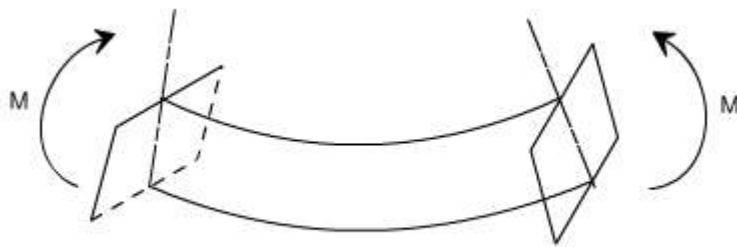
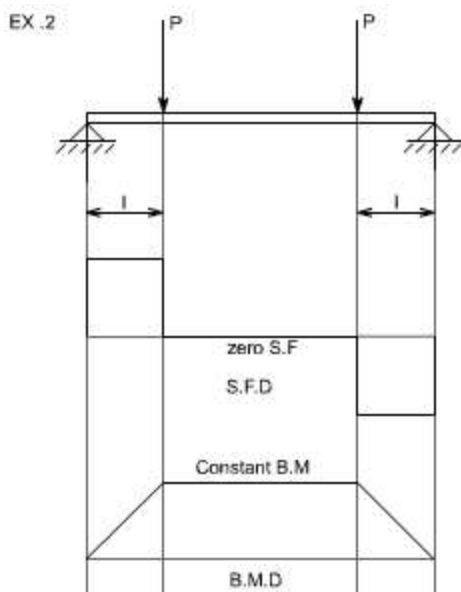
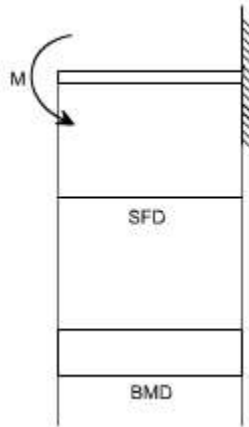

Fig (2)

When a member is loaded in such a fashion it is said to be in **pure bending**. The examples of pure bending have been indicated in EX 1 and EX 2 as shown below :



EX. 1



When a beam is subjected to pure bending and loaded by the couples at the ends, certain cross-section gets deformed and we shall have to make out the conclusion that,

1. Plane sections originally perpendicular to longitudinal axis of the beam remain plane and perpendicular to the longitudinal axis even after bending, i.e. the cross-section A'E', B'F' (refer Fig 1(a)) do not get warped or curved.
2. In the deformed section, the planes of this cross-section have a common intersection i.e. any line originally parallel to the longitudinal axis of the beam becomes an arc of circle.

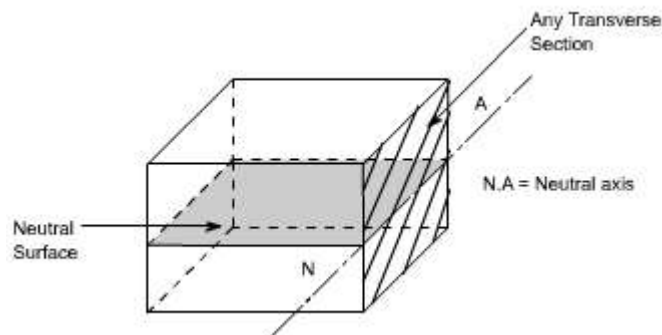

We know that when a beam is under bending the fibres at the top will be lengthened while at the bottom will be shortened provided the bending moment M acts at the ends. In between these there are some fibres which remain unchanged in length that is they are not strained, that is they do not carry any stress. The plane containing such fibres is called neutral surface.

The line of intersection between the neutral surface and the transverse exploratory section is called the neutral axis **(N A)**.

Bending Stresses in Beams or Derivation of Elastic Flexural formula :

In order to compute the value of bending stresses developed in a loaded beam, let us consider the two cross-sections of a beam **HE** and **GF**, originally parallel as shown in fig 1(a). when the beam is to bend it is assumed that these sections remain parallel i.e. **H'E'** and **G'F'**, the final position of the sections, are still straight lines, they then subtend some angle θ .

Consider now fiber AB in the material, at a distance y from the N.A, when the beam bends this will stretch to A'B'

Therefore,

$$\text{strain in fibre AB} = \frac{\text{change in length}}{\text{original length}}$$

$$= \frac{A'B' - AB}{AB} \quad \text{But } AB = CD \text{ and } CD = C'D'$$

refer to fig1(a) and fig1(b)

$$\therefore \text{strain} = \frac{A'B' - C'D'}{C'D'}$$

Since CD and C'D' are on the neutral axis and it is assumed that the Stress on the neutral axis zero. Therefore, there won't be any strain on the neutral axis

$$= \frac{(R + y)\theta - R\theta}{R\theta} = \frac{R\theta + y\theta - R\theta}{R\theta} = \frac{y}{R}$$

However $\frac{\text{stress}}{\text{strain}} = E$ where $E = \text{Young's Modulus of elasticity}$

Therefore, equating the two strains as obtained from the two relations i.e.,

$$\frac{\sigma}{E} = \frac{y}{R} \text{ or } \frac{\sigma}{y} = \frac{E}{R} \quad \dots\dots\dots(1)$$

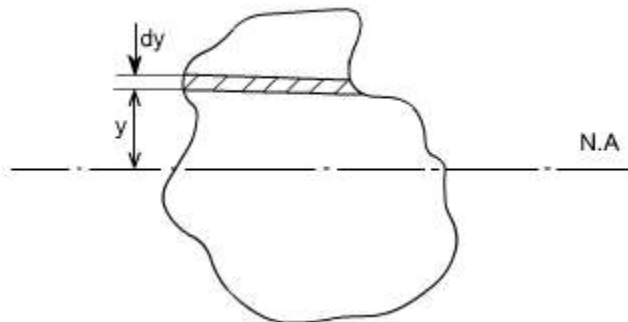

Consider any arbitrary a cross-section of beam, as shown above now the strain on a fibre at a distance 'y' from the N.A, is given by the expression

$$\sigma = \frac{E}{R} y$$

if the shaded strip is of area 'dA'

then the force on the strip is

$$F = \sigma \delta A = \frac{E}{R} y \delta A$$

Moment about the neutral axis would be = $F \cdot y = \frac{E}{R} y^2 \delta A$

The total moment for the whole cross-section is therefore equal to

$$M = \sum \frac{E}{R} y^2 \delta A = \frac{E}{R} \sum y^2 \delta A$$

Now the term $\sum y^2 \delta A$ is the property of the material and is called as a second moment of area of the cross-section and is denoted by a symbol I.

Therefore

$$M = \frac{E}{R} I \quad \dots\dots\dots(2)$$

combining equation 1 and 2 we get

$$\boxed{\frac{\sigma}{y} = \frac{M}{I} = \frac{E}{R}}$$

This equation is known as the Bending Theory Equation. The above proof has involved the assumption of pure bending without any shear force being present. Therefore this termed as the pure bending equation. This equation gives distribution of stresses which are normal to cross-section i.e. in x-direction.

Section Modulus:

From simple bending theory equation, the maximum stress obtained in any cross-section is given as

$$\sigma_{\max} = \frac{M}{I} y_{\max}$$

For any given allowable stress the maximum moment which can be accepted by a particular shape of cross-section is therefore

$$M = \frac{I}{y_{\max}} \sigma_{\max}$$

For ready comparison of the strength of various beam cross-section this relationship is some times written in the form

$$M = Z \sigma_{\max} \quad \text{where } Z = \frac{I}{y_{\max}} \quad \text{Is termed as section modulus}$$

The higher value of Z for a particular cross-section, the higher the bending moment which it can withstand for a given maximum stress.

Theorems to determine second moment of area: There are two theorems which are helpful to determine the value of second moment of area, which is required to be used while solving the simple bending theory equation.

Second Moment of Area :

Taking an analogy from the mass moment of inertia, the second moment of area is defined as the summation of areas times the distance squared from a fixed axis. (This property arised while we were driving bending theory equation). This is also known as the moment of inertia. An alternative name given to this is second moment of area, because the first moment being the sum of areas times their distance from a given axis and the second moment being the square of the distance or $\int y^2 dA$.

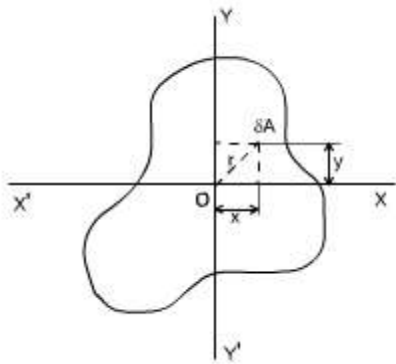

Consider any cross-section having small element of area dA then by the definition

$$I_x(\text{Mass Moment of Inertia about x-axis}) = \int y^2 dA \quad \text{and} \quad I_y(\text{Mass Moment of Inertia about y-axis}) = \int x^2 dA$$

Now the moment of inertia about an axis through 'O' and perpendicular to the plane of figure is called the polar moment of inertia. (The polar moment of inertia is also the area moment of inertia).

i.e,

$$J = \text{polar moment of inertia}$$

$$\begin{aligned}
&= \int r^2 dA \\
&= \int (x^2 + y^2) dA \\
&= \int x^2 dA + \int y^2 dA \\
&= I_x + I_y \\
\text{or } J &= I_x + I_y \quad \dots\dots\dots (1)
\end{aligned}$$

The relation (1) is known as the **perpendicular axis theorem** and may be stated as follows:

The sum of the Moment of Inertia about any two axes in the plane is equal to the moment of inertia about an axis perpendicular to the plane, the three axes being concurrent, i.e, the three axes exist together.

CIRCULAR SECTION :

For a circular x-section, the polar moment of inertia may be computed in the following manner

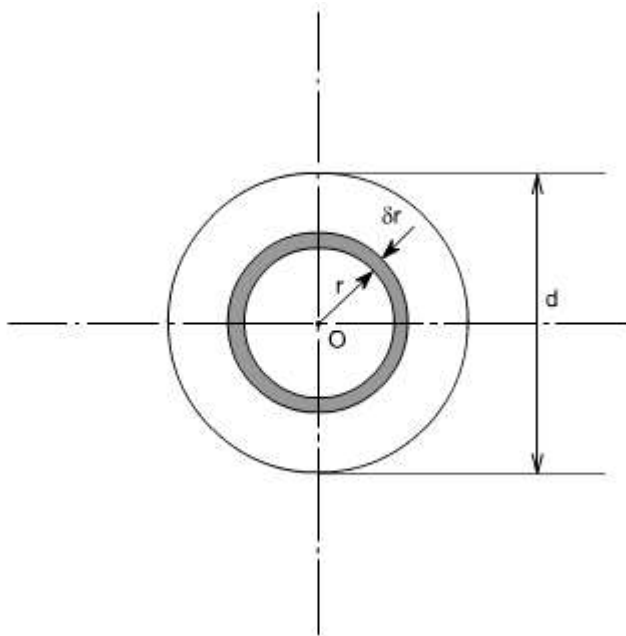

Consider any circular strip of thickness dr located at a radius ' r '.

Then the area of the circular strip would be $dA = 2\pi r \cdot dr$

$$J = \int r^2 dA$$

Taking the limits of integration from 0 to $d/2$

$$J = \int_0^{\frac{d}{2}} r^2 2\pi r dr$$

$$= 2\pi \int_0^{\frac{d}{2}} r^3 dr$$

$$J = 2\pi \left[\frac{r^4}{4} \right]_0^{\frac{d}{2}} = \frac{\pi d^4}{32}$$

however, by perpendicular axis theorem

$$J = I_x + I_y$$

But for the circular cross-section, the I_x and I_y are both equal being moment of inertia about a diameter

$$I_{\text{dia}} = \frac{1}{2} J$$

$$I_{\text{dia}} = \frac{\pi d^4}{64}$$

for a hollow circular section of diameter D and d , the values of J and I are defined as

$$J = \frac{\pi(D^4 - d^4)}{32}$$

$$I = \frac{\pi(D^4 - d^4)}{64}$$

Thus

Parallel Axis Theorem:

The moment of inertia about any axis is equal to the moment of inertia about a parallel axis through the centroid plus the area times the square of the distance between the axes.

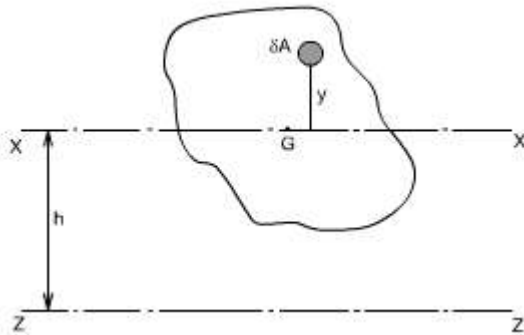

If 'ZZ' is any axis in the plane of cross-section and 'XX' is a parallel axis through the centroid G, of the cross-section, then

$$\begin{aligned}
 I_z &= \int (y+h)^2 dA \text{ by definition (moment of inertia about an axis ZZ)} \\
 &= \int (y^2 + 2yh + h^2) dA \\
 &= \int y^2 dA + h^2 \int dA + 2h \int y dA \\
 &\qquad\qquad\qquad \text{Since } \int y dA = 0 \\
 &= \int y^2 dA + h^2 \int dA \\
 &= \int y^2 dA + h^2 A \\
 I_z &= I_x + Ah^2 \quad I_x = I_G \text{ (since cross-section axes also pass through G)} \\
 &\qquad\qquad\qquad \text{Where } A = \text{Total area of the section}
 \end{aligned}$$

Rectangular Section:

For a rectangular x-section of the beam, the second moment of area may be computed as below :

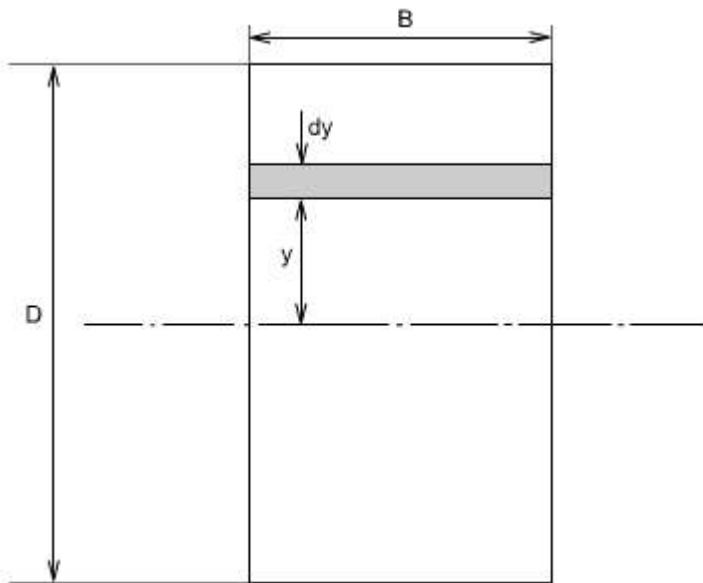

Consider the rectangular beam cross-section as shown above and an element of area dA , thickness dy , breadth B located at a distance y from the neutral axis, which by symmetry passes through the centre of section. The second moment of area I as defined earlier would be

$$I_{N.A} = \int y^2 dA$$

Thus, for the rectangular section the second moment of area about the neutral axis i.e., an axis through the centre is given by

$$\begin{aligned}
I_{N.A} &= \int_{-\frac{D}{2}}^{\frac{D}{2}} y^2 (B \, dy) \\
&= B \int_{-\frac{D}{2}}^{\frac{D}{2}} y^2 \, dy \\
&= B \left[\frac{y^3}{3} \right]_{-\frac{D}{2}}^{\frac{D}{2}} \\
&= \frac{B}{3} \left[\frac{D^3}{8} - \left(\frac{-D^3}{8} \right) \right] \\
&= \frac{B}{3} \left[\frac{D^3}{8} + \frac{D^3}{8} \right] \\
I_{N.A} &= \frac{BD^3}{12}
\end{aligned}$$

Similarly, the second moment of area of the rectangular section about an axis through the lower edge of the section would be found using the same procedure but with integral limits of **0** to **D** .

Therefore
$$I = B \left[\frac{y^3}{3} \right]_0^D = \frac{BD^3}{3}$$

These standard formulas prove very convenient in the determination of I_{NA} for build up sections which can be conveniently divided into rectangles. For instance if we just want to find out the Moment of Inertia of an I - section, then we can use the above relation.

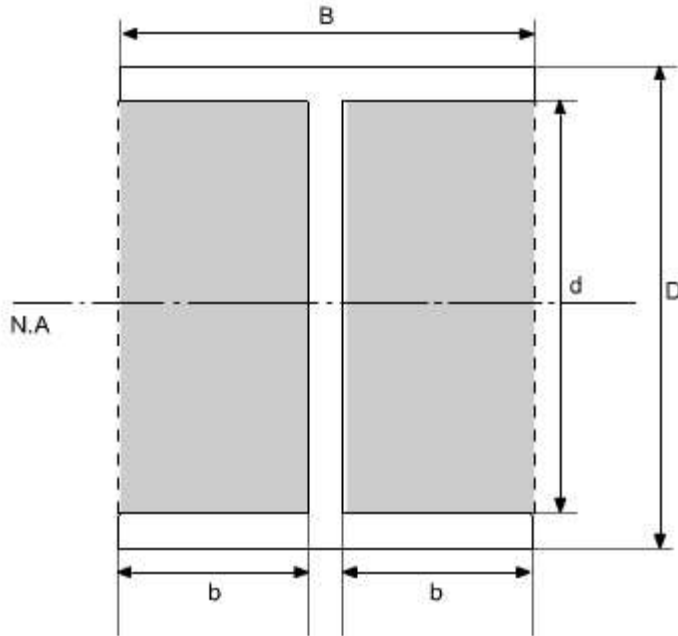

$$I_{N.A.} = I_{\text{of dotted rectangle}} - I_{\text{of shaded portion}}$$

$$\therefore I_{N.A.} = \frac{BD^3}{12} - 2\left(\frac{bd^3}{12}\right)$$

$$I_{N.A.} = \frac{BD^3}{12} - \frac{bd^3}{6}$$

LECTURE 27

Use of Flexure Formula:

Illustrative Problems:

An I - section girder, 200mm wide by 300 mm depth flange and web of thickness is 20 mm is used as simply supported beam for a span of 7 m. The girder carries a distributed load of 5 KN /m and a concentrated load of 20 KN at mid-span.

Determine the

- (i). The second moment of area of the cross-section of the girder
- (ii). The maximum stress set up.

Solution:

The second moment of area of the cross-section can be determined as follows :

For sections with symmetry about the neutral axis, use can be made of standard I value

for a rectangle about an axis through centroid i.e. $(bd^3)/12$. The section can thus be divided into convenient rectangles for each of which the neutral axis passes through the centroid. Example in the case enclosing the girder by a rectangle

$$\begin{aligned}
 I_{\text{girder}} &= I_{\text{rectangle}} - I_{\text{shaded portion}} \\
 &= \left[\frac{200 \times 300^3}{12} \right] 10^{-12} - 2 \left[\frac{90 \times 260^3}{12} \right] 10^{-12} \\
 &= (4.5 - 2.64) 10^{-4} \\
 &= 1.86 \times 10^{-4} \text{ m}^4
 \end{aligned}$$

The maximum stress may be found from the simple bending theory by equation

$$\frac{\sigma}{y} = \frac{M}{I} = \frac{E}{R}$$

i.e.

$$\sigma_{\text{max}^m} = \frac{M_{\text{max}^m}}{I} y_{\text{max}^m}$$

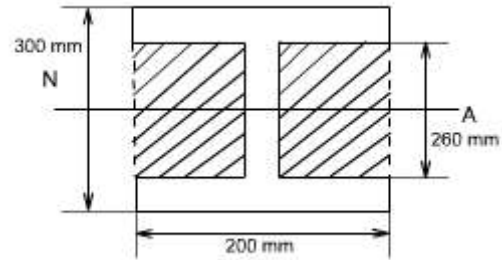

Computation of Bending Moment:

In this case the loading of the beam is of two types

- (a) Uniformly distributed load
- (b) Concentrated Load

In order to obtain the maximum bending moment the technique will be to consider each loading on the beam separately and get the bending moment due to it as if no other forces acting on the structure and then superimpose the two results.

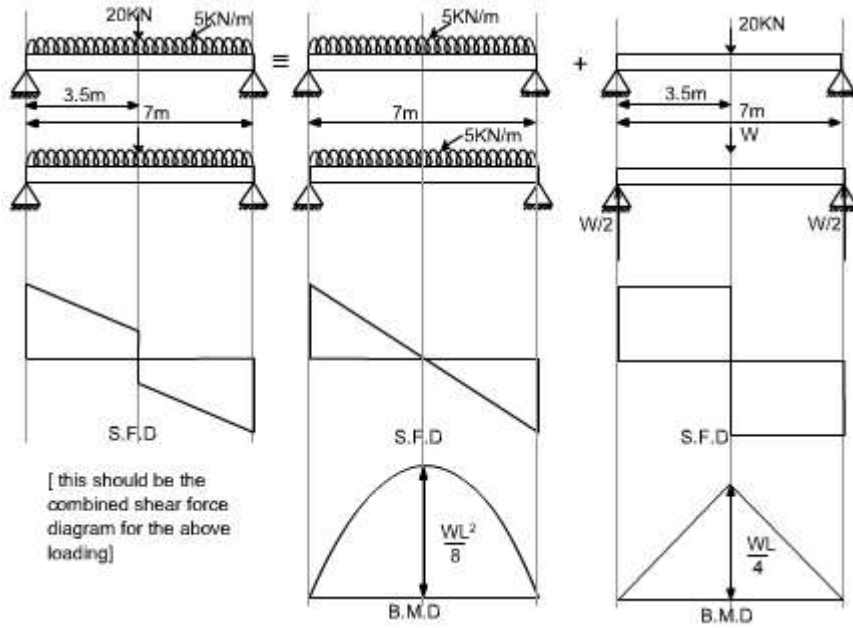

Hence

$$\begin{aligned}
 M_{\max}^m &= \frac{wL}{4} + \frac{wL^2}{8} \\
 &= \frac{20 \times 10^3 \times 7}{4} + \frac{5 \times 10^3 \times 7^2}{8} \\
 &= (35.0 + 30.63) 10^3 \\
 &= 65.63 \text{ kNm}
 \end{aligned}$$

$$\begin{aligned}
 \sigma_{\max}^m &= \frac{M_{\max}^m}{I} y_{\max}^m \\
 &= \frac{65.63 \times 10^3 \times 150 \times 10^3}{1.06 \times 10^{-4}}
 \end{aligned}$$

$$\sigma_{\max}^m = 51.8 \text{ MN/m}^2$$

Shearing Stresses in Beams

All the theory which has been discussed earlier, while we discussed the bending stresses in beams was for the case of pure bending i.e. constant bending moment acts along the entire length of the beam.

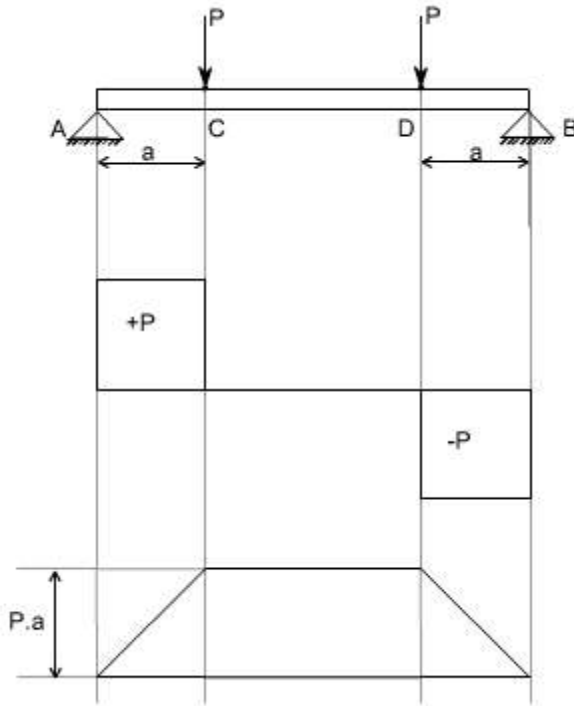

Let us consider the beam AB transversely loaded as shown in the figure above. Together with shear force and bending moment diagrams we note that the middle portion CD of the beam is free from shear force and that its bending moment, $M = P \cdot a$ is uniform between the portion C and D. This condition is called the pure bending condition.

Since shear force and bending moment are related to each other $F = dM/dX$ (eq) therefore if the shear force changes then there will be a change in the bending moment also, and then this won't be the pure bending.

Conclusions :

Hence one can conclude from the pure bending theory was that the shear force at each X-section is zero and the normal stresses due to bending are the only ones produced.

In the case of non-uniform bending of a beam where the bending moment varies from one X-section to another, there is a shearing force on each X-section and shearing stresses are also induced in the material. The deformation associated with those shearing stresses causes “warping” of the x-section so that the assumption which we assumed

while deriving the relation $\frac{\sigma}{y} = \frac{M}{I} = \frac{E}{R}$ that the plane cross-section after bending remains plane is violated. Now due to warping the plane cross-section before bending do not remain plane after bending. This complicates the problem but more elaborate analysis

shows that the normal stresses due to bending, as calculated from the equation $\frac{\sigma}{y} = \frac{M}{I} = \frac{E}{R}$.

The above equation gives the distribution of stresses which are normal to the cross-section that is in x-direction or along the span of the beam are not greatly altered by the presence of these shearing stresses. Thus, it is justifiable to use the theory of pure bending in the case of non uniform bending and it is accepted practice to do so.

Let us study the shear stresses in the beams.

Concept of Shear Stresses in Beams :

By the earlier discussion we have seen that the bending moment represents the resultant of certain linear distribution of normal stresses s_x over the cross-section. Similarly, the shear force F_x over any cross-section must be the resultant of a certain distribution of shear stresses.

Derivation of equation for shearing stress :

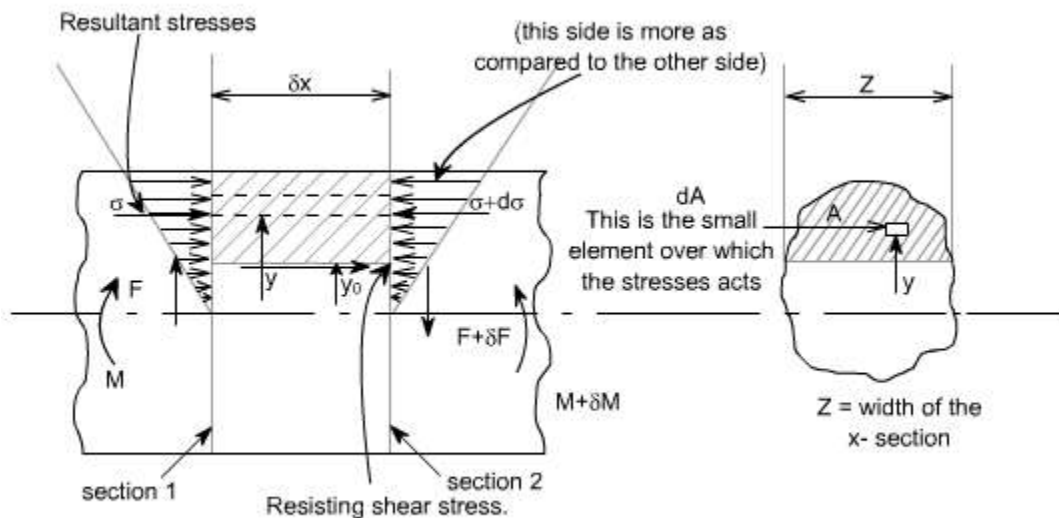

Assumptions :

1. Stress is uniform across the width (i.e. parallel to the neutral axis)
2. The presence of the shear stress does not affect the distribution of normal bending stresses.

It may be noted that the assumption no.2 cannot be rigidly true as the existence of shear stress will cause a distortion of transverse planes, which will no longer remain plane.

In the above figure let us consider the two transverse sections which are at a distance ' δx ' apart. The shearing forces and bending moments being F , $F + \delta F$ and M , $M + \delta M$

respectively. Now due to the shear stress on transverse planes there will be a complementary shear stress on longitudinal planes parallel to the neutral axis.

Let t be the value of the complementary shear stress (and hence the transverse shear stress) at a distance ' Y' ' from the neutral axis. Z is the width of the x-section at this position

A is area of cross-section cut-off by a line parallel to the neutral axis.

\bar{Y} = distance of the centroid of Area from the neutral axis.

Let s , $s + ds$ are the normal stresses on an element of area dA at the two transverse sections, then there is a difference of longitudinal forces equal to $(ds \cdot dA)$, and this quantity summed over the area A is in equilibrium with the transverse shear stress t on the longitudinal plane of area $z dx$.

$$\text{i.e. } \tau \cdot z \delta x = \int d\sigma \cdot dA$$

from the bending theory equation

$$\frac{\sigma}{y} = \frac{M}{I}$$

$$\sigma = \frac{M \cdot y}{I}$$

$$\sigma + d\sigma = \frac{(M + \delta M) \cdot y}{I}$$

$$\text{Thus } d\sigma = \frac{\delta M \cdot y}{I}$$

The figure shown below indicates the pictorial representation of the part.

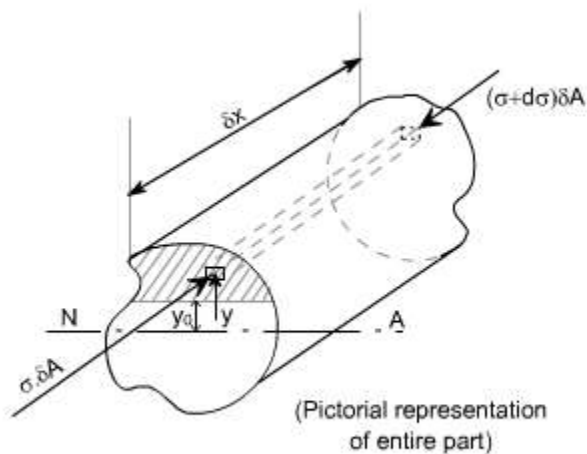

$$d\sigma = \frac{\delta M \cdot y}{I}$$

$$\tau \cdot z \delta x = \int d\sigma \cdot dA$$

$$= \int \frac{\delta M \cdot y \cdot \delta A}{I}$$

$$\tau \cdot z \delta x = \frac{\delta M}{I} \int y \cdot \delta A$$

But $F = \frac{\delta M}{\delta x}$

i.e. $\tau = \frac{F}{I \cdot z} \int y \cdot \delta A$

But from definition, $\int y \cdot dA = A \bar{y}$

$\int y \cdot dA$ is the first moment of area of the shaded portion

and \bar{y} = centroid of the area 'A'

Hence

$$\tau = \frac{F \cdot A \cdot \bar{y}}{I \cdot z}$$

So substituting

Where 'z' is the actual width of the section at the position where 't' is being calculated and I is the total moment of inertia about the neutral axis.

LECTURE 28 and 29

Shearing stress distribution in typical cross-sections:

Let us consider few examples to determine the shear stress distribution in a given X-sections

Rectangular x-section:

Consider a rectangular x-section of dimension b and d

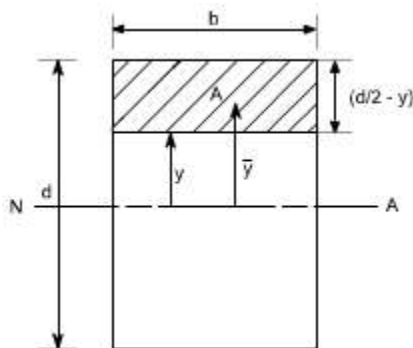

A is the area of the x-section cut off by a line parallel to the neutral axis. \bar{y} is the distance of the centroid of A from the neutral axis

$$\tau = \frac{F.A.\bar{y}}{l.z}$$

for this case, $A = b\left(\frac{d}{2} - y\right)$

While $\bar{y} = \left[\frac{1}{2}\left(\frac{d}{2} - y\right) + y\right]$

i.e $\bar{y} = \frac{1}{2}\left(\frac{d}{2} + y\right)$ and $z = b; l = \frac{b.d^3}{12}$

substituting all these values, in the formula

$$\begin{aligned} \tau &= \frac{F.A.\bar{y}}{l.z} \\ &= \frac{F.b\left(\frac{d}{2} - y\right) \cdot \frac{1}{2}\left(\frac{d}{2} + y\right)}{b \cdot \frac{b.d^3}{12}} \\ &= \frac{F}{2} \cdot \frac{\left\{\left(\frac{d}{2}\right)^2 - y^2\right\}}{\frac{b.d^3}{12}} \\ &= \frac{6.F \cdot \left\{\left(\frac{d}{2}\right)^2 - y^2\right\}}{b.d^3} \end{aligned}$$

This shows that there is a parabolic distribution of shear stress with y.

The maximum value of shear stress would obviously be at the location $y = 0$.

$$\begin{aligned} \text{Such that } \tau_{\max} &= \frac{6.F}{b.d^3} \cdot \frac{d^2}{4} \\ &= \frac{3.F}{2.b.d} \end{aligned}$$

So $\tau_{\max} = \frac{3.F}{2.b.d}$ The value of τ_{\max} occurs at the neutral axis

The mean shear stress in the beam is defined as

$$\begin{aligned} \tau_{\text{mean or } \tau_{\text{avg}}} &= F/A = F/b.d \\ \text{So } \tau_{\max} &= 1.5 \tau_{\text{mean}} = 1.5 \tau_{\text{avg}} \end{aligned}$$

Therefore the shear stress distribution is shown as below.

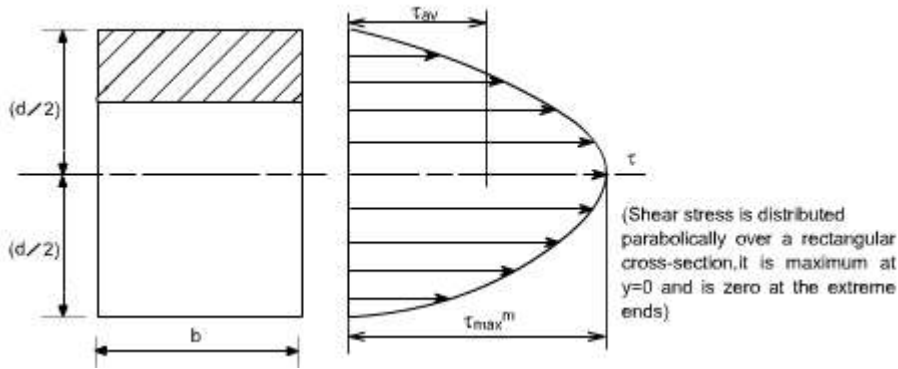

It may be noted that the shear stress is distributed parabolically over a rectangular cross-section, it is maximum at $y = 0$ and is zero at the extreme ends.

I - section :

Consider an I - section of the dimension shown below.

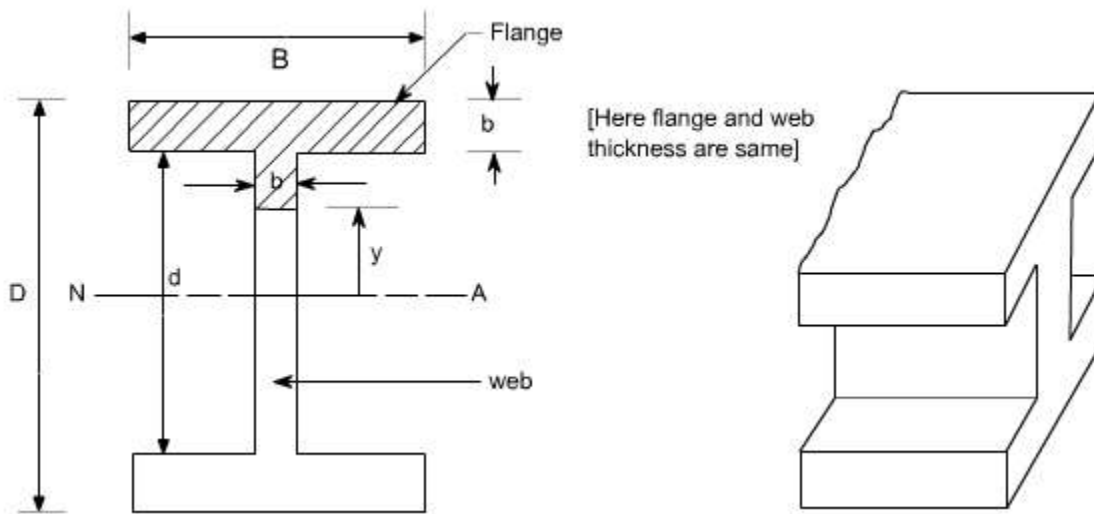

The shear stress distribution for any arbitrary shape is given as $\tau = \frac{F A \bar{y}}{Z I}$

Let us evaluate the quantity $A\bar{y}$, the $A\bar{y}$ quantity for this case comprise the contribution due to flange area and web area

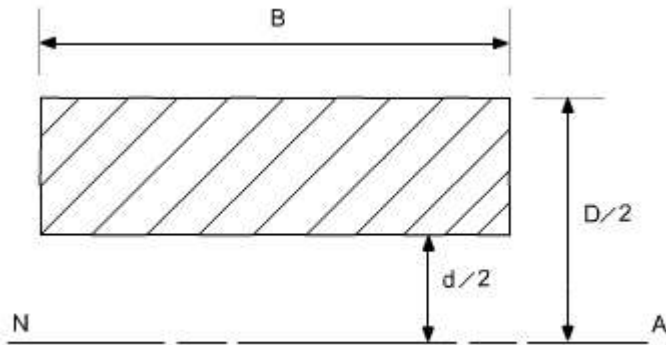

Flange area

Area of the flange = $B \left(\frac{D - d}{2} \right)$

Distance of the centroid of the flange from the N.A

$$\bar{y} = \frac{1}{2} \left(\frac{D - d}{2} \right) + \frac{d}{2}$$

$$\bar{y} = \left(\frac{D + d}{4} \right)$$

Hence,

$$A\bar{y}|_{\text{Flange}} = B \left(\frac{D - d}{2} \right) \left(\frac{D + d}{4} \right)$$

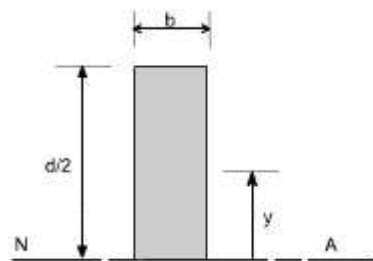

Web Area

Area of the web

$$A = b \left(\frac{d}{2} - y \right)$$

Distance of the centroid from N.A

$$\bar{y} = \frac{1}{2} \left(\frac{d}{2} - y \right) + y$$

$$\bar{y} = \frac{1}{2} \left(\frac{d}{2} + y \right)$$

Therefore,

$$A\bar{y}|_{web} = b \left(\frac{d}{2} - y \right) \frac{1}{2} \left(\frac{d}{2} + y \right)$$

Hence,

$$A\bar{y}|_{Total} = B \left(\frac{D-d}{2} \right) \left(\frac{D+d}{4} \right) + b \left(\frac{d}{2} - y \right) \left(\frac{d}{2} + y \right) \frac{1}{2}$$

Thus,

$$A\bar{y}|_{Total} = B \left(\frac{D^2 - d^2}{8} \right) + \frac{b}{2} \left(\frac{d^2}{4} - y^2 \right)$$

Therefore shear stress,

$$\tau = \frac{F}{bI} \left[\frac{B(D^2 - d^2)}{8} + \frac{b}{2} \left(\frac{d^2}{4} - y^2 \right) \right]$$

To get the maximum and minimum values of τ substitute in the above relation.

$y = 0$ at N. A. And $y = d/2$ at the tip.

The maximum shear stress is at the neutral axis. i.e. for the condition $y = 0$ at N. A.

$$\text{Hence, } \tau_{\max} \text{ at } y=0 = \frac{F}{8bI} \left[B(D^2 - d^2) + bd^2 \right] \quad \dots\dots\dots(2)$$

The minimum stress occur at the top of the web, the term bd^2 goes off and shear stress is given by the following expression

$$\tau_{\min} \text{ at } y = d/2 = \frac{F}{8bI} \left[B(D^2 - d^2) \right] \quad \dots\dots\dots(3)$$

The distribution of shear stress may be drawn as below, which clearly indicates a parabolic distribution

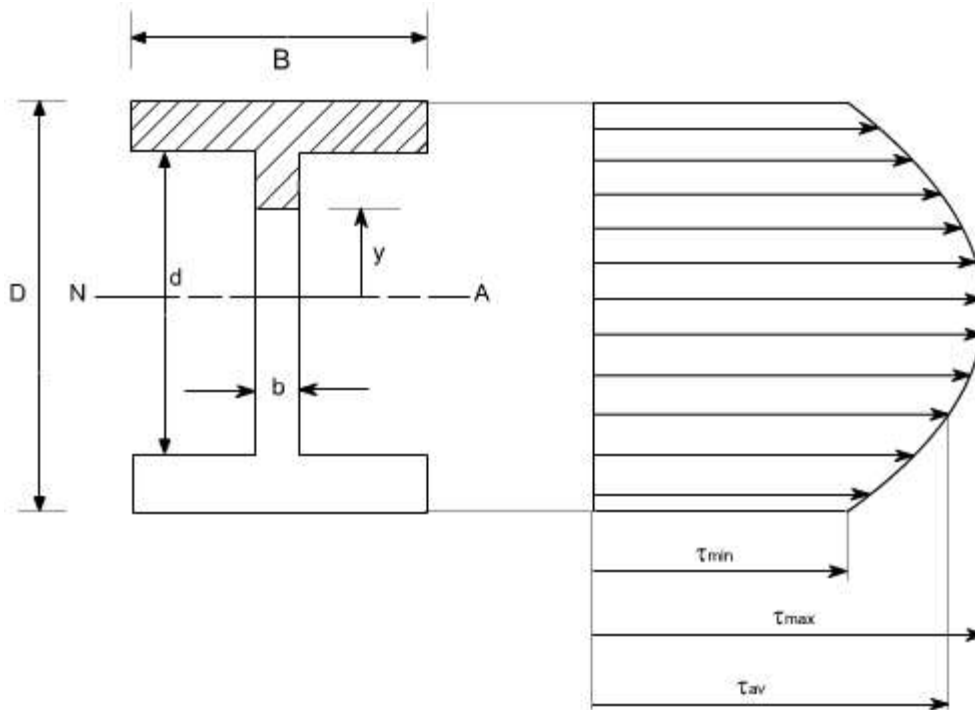

$$\tau_{\max}^m = \frac{F}{8bl} \left[B (D^2 - d^2) + bd^2 \right]$$

Note: from the above distribution we can see that the shear stress at the flanges is not zero, but it has some value, this can be analyzed from equation (1). At the flange tip or flange or web interface $y = d/2$. Obviously than this will have some constant value and than onwards this will have parabolic distribution.

In practice it is usually found that most of shearing stress usually about 95% is carried by the web, and hence the shear stress in the flange is negligible however if we have the concrete analysis i.e. if we analyze the shearing stress in the flange i.e. writing down the expression for shear stress for flange and web separately, we will have this type of variation.

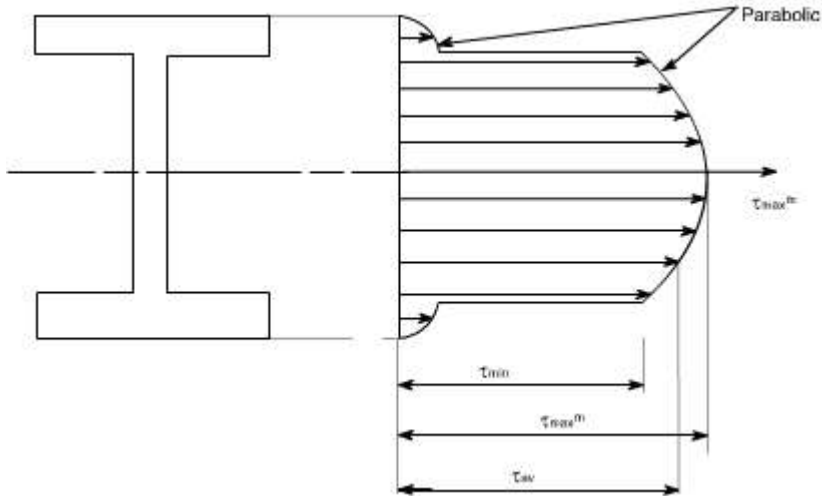

This distribution is known as the “top – hat” distribution. Clearly the web bears the most of the shear stress and bending theory we can say that the flange will bear most of the bending stress.

Shear stress distribution in beams of circular cross-section:

Let us find the shear stress distribution in beams of circular cross-section. In a beam of circular cross-section, the value of Z width depends on y.

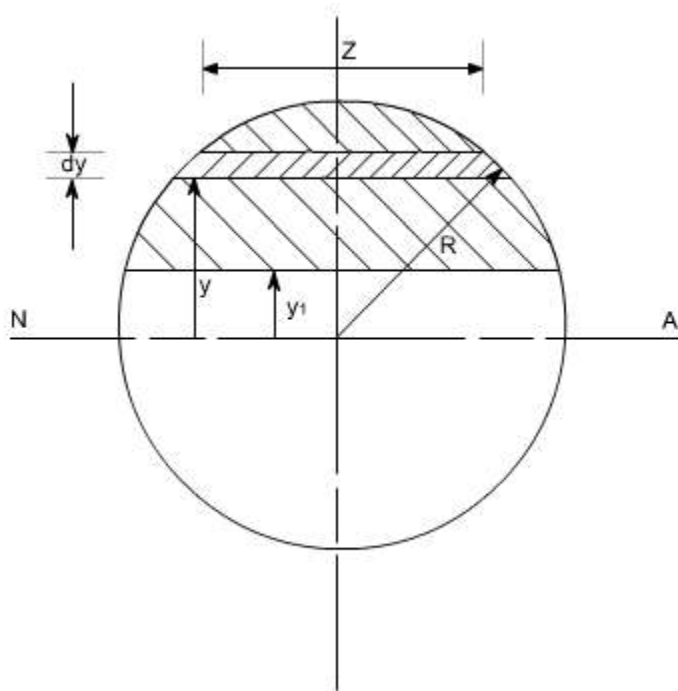

Using the expression for the determination of shear stresses for any arbitrary shape or a arbitrary section.

$$\tau = \frac{FA \bar{y}}{ZI} = \frac{FA \int y dA}{ZI}$$

Where $\int y dA$ is the area moment of the shaded portion or the first moment of area.

Here in this case 'dA' is to be found out using the Pythagoras theorem

$$\left(\frac{Z}{2}\right)^2 + y^2 = R^2$$

$$\left(\frac{Z}{2}\right)^2 = R^2 - y^2 \text{ or } \frac{Z}{2} = \sqrt{R^2 - y^2}$$

$$Z = 2\sqrt{R^2 - y^2}$$

$$dA = Z dy = 2\sqrt{R^2 - y^2} \cdot dy$$

$$I_{N.A} \text{ for a circular cross-section} = \frac{\pi R^4}{4}$$

Hence,

$$\tau = \frac{FA \bar{y}}{ZI} = \frac{F}{\frac{\pi R^4}{4} \cdot 2\sqrt{R^2 - y^2}} \int_{y_1}^R 2y\sqrt{R^2 - y^2} dy$$

Where R = radius of the circle.

[The limits have been taken from y_1 to R because we have to find moment of area the shaded portion]

$$= \frac{4F}{\pi R^4 \sqrt{R^2 - y^2}} \int_{y_1}^R y\sqrt{R^2 - y^2} dy$$

The integration yields the final result to be

$$\tau = \frac{4F(R^2 - y_1^2)}{3\pi R^4}$$

Again this is a parabolic distribution of shear stress, having a maximum value when $y_1 = 0$

$$\tau_{\max} |_{y_1=0} = \frac{4F}{3\pi R^2}$$

Obviously at the ends of the diameter the value of $y_1 = \pm R$ thus $\tau = 0$ so this again a parabolic distribution; maximum at the neutral axis

Also

$$\tau_{\text{avg}} \text{ or } \tau_{\text{mean}} = \frac{F}{A} = \frac{F}{\pi R^2}$$

Hence,

$$\boxed{\tau_{\max} = \frac{4}{3} \tau_{\text{avg}}}$$

The distribution of shear stresses is shown below, which indicates a parabolic distribution

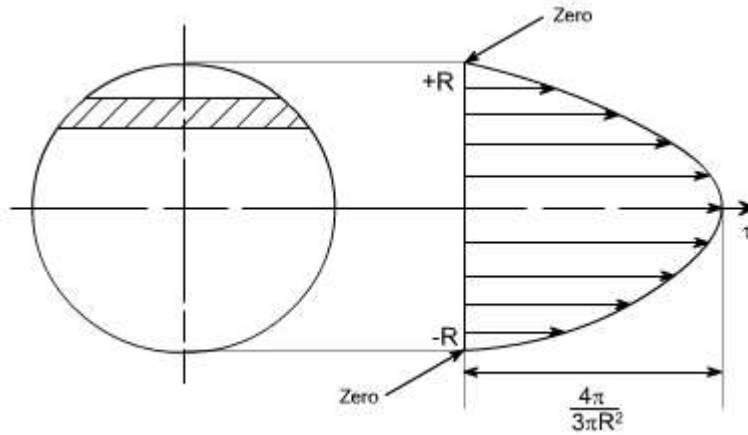

Principal Stresses in Beams

It becomes clear that the bending stress in beam s_x is not a principal stress, since at any distance y from the neutral axis; there is a shear stress t (or t_{xy} we are assuming a plane stress situation)

In general the state of stress at a distance y from the neutral axis will be as follows.

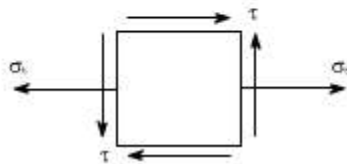
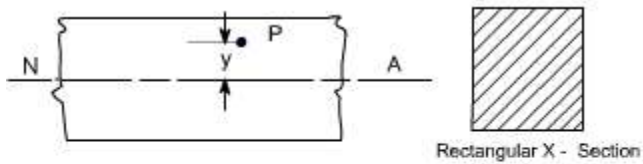

At some point 'P' in the beam, the value of bending stresses is given as

$$\sigma_b = \frac{My}{I} \text{ for a beam of rectangular cross-section of dimensions } b \text{ and } d; I = \frac{bd^3}{12}$$

$$\sigma_b = \frac{12 My}{bd^3}$$

whereas the value shear stress in the rectangular cross-section is given as

$$\tau = \frac{6F}{bd^3} \left[\frac{d^2}{4} - y^2 \right]$$

Hence the values of principle stress can be determined from the relations,

$$\sigma_1, \sigma_2 = \frac{1}{2}(\sigma_x + \sigma_y) \pm \frac{1}{2} \sqrt{(\sigma_x - \sigma_y)^2 + 4\tau_{xy}^2}$$

Letting $\sigma_y = 0$; $\sigma_x = \sigma_b$, the values of σ_1 and σ_2 can be computed as

$$\text{Hence } \sigma_1 / \sigma_2 = \frac{1}{2} \left(\frac{12My}{bd^3} \right) \pm \frac{1}{2} \sqrt{\left(\frac{12My}{bd^3} \right)^2 + 4 \left(\frac{6F}{bd^3} \left(\frac{d^2}{4} - y^2 \right) \right)^2}$$

$$\sigma_1, \sigma_2 = \frac{6}{bd^3} \left[My \pm \sqrt{M^2 y^2 + F^2 \left(\frac{d^2}{4} - y^2 \right)^2} \right]$$

Also,

$$\tan 2\theta = \frac{2\tau_{xy}}{\sigma_x - \sigma_y} \quad \text{putting } \sigma_y = 0$$

we get,

$$\tan 2\theta = \frac{2\tau_{xy}}{\sigma_x}$$

After substituting the appropriate values in the above expression we may get the inclination of the principal planes.

Illustrative examples: Let us study some illustrative examples, pertaining to determination of principal stresses in a beam

1. Find the principal stress at a point A in a uniform rectangular beam 200 mm deep and 100 mm wide, simply supported at each end over a span of 3 m and carrying a uniformly distributed load of 15,000 N/m.

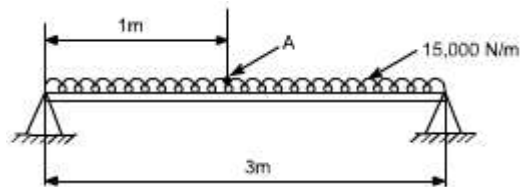

Solution: The reaction can be determined by symmetry

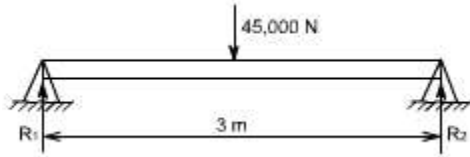

$$R_1 = R_2 = 22,500 \text{ N}$$

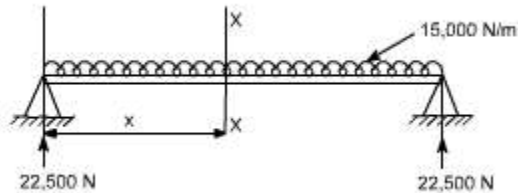

consider any cross-section X-X located at a distance x from the left end.

Hence,

$$S. F \text{ at } XX = 22,500 - 15,000 x$$

$$B.M \text{ at } XX = 22,500 x - 15,000 x (x/2) = 22,500 x - 15,000 \cdot x^2 / 2$$

Therefore,

$$S. F \text{ at } X = 1 \text{ m} = 7,500 \text{ N}$$

$$B. M \text{ at } X = 1 \text{ m} = 15,000 \text{ N}$$

$$S.F|_{x=1m} = 7,500 \text{ N}$$

$$BM|_{x=1m} = 15,000 \text{ N.m}$$

$$\sigma_x = \frac{My}{I}$$

$$= \frac{15,000 \times 5 \times 10^{-2} \times 12}{10 \times 10^{-12} \times (20 \times 10^{-2})^3}$$

$$\sigma_x = 11.25 \text{ MN/m}^2$$

For the computation of shear stresses

$$\tau = \frac{6F}{bd^3} \left[\frac{d^2}{4} - y^2 \right] \quad \text{putting } y = 50 \text{ mm, } d = 200 \text{ mm}$$

$$F = 7500 \text{ N}$$

$$\tau = 0.422 \text{ MN/m}^2$$

Now substituting these values in the principal stress equation,

$$\text{We get } s_1 = 11.27 \text{ MN/m}^2$$

$$s_2 = - 0.025 \text{ MN/m}^2$$

Bending Of Composite or Flitched Beams

A composite beam is defined as the one which is constructed from a combination of materials. If such a beam is formed by rigidly bolting together two timber joists and a reinforcing steel plate, then it is termed as a flitched beam.

The bending theory is valid when a constant value of Young's modulus applies across a section it cannot be used directly to solve the composite-beam problems where two different materials, and therefore different values of E , exists. The method of solution in such a case is to replace one of the materials by an equivalent section of the other.

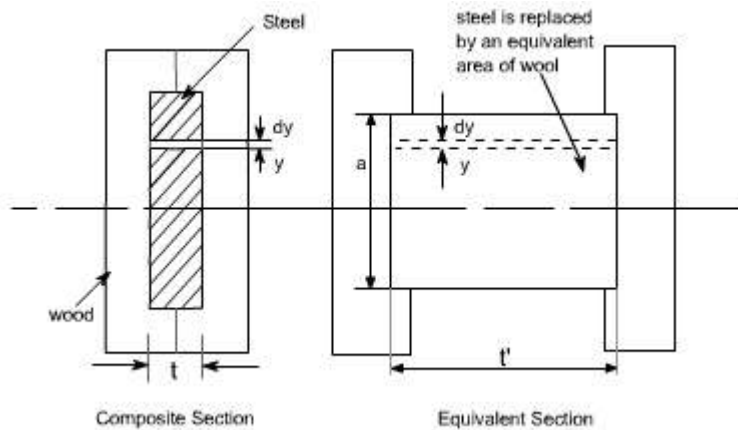

Consider, a beam as shown in figure in which a steel plate is held centrally in an appropriate recess/pocket between two blocks of wood .Here it is convenient to replace the steel by an equivalent area of wood, retaining the same bending strength. i.e. the moment at any section must be the same in the equivalent section as in the original section so that the force at any given dy in the equivalent beam must be equal to that at the strip it replaces.

$$\sigma \cdot t = \sigma' \cdot t' \text{ or } \boxed{\frac{\sigma}{\sigma'} = \frac{t'}{t}}$$

recalling $\sigma = E \cdot \varepsilon$

Thus

$$\varepsilon E t = \varepsilon' E' t'$$

Again, for true similarity the strains must be equal,

$$\varepsilon = \varepsilon' \text{ or } E t = E' t' \text{ or } \boxed{\frac{E'}{E} = \frac{t}{t'}}$$

Thus, $\boxed{t' = \frac{E}{E'} \cdot t}$

Hence to replace a steel strip by an equivalent wooden strip the thickness must be

multiplied by the modular ratio E/E' .

The equivalent section is then one of the same materials throughout and the simple bending theory applies. The stress in the wooden part of the original beam is found directly and that in the steel found from the value at the same point in the equivalent material as follows by utilizing the given relations.

$$\frac{\sigma}{\sigma'} = \frac{t}{t'}$$
$$\frac{\sigma}{\sigma'} = \frac{E}{E'}$$

Stress in steel = modular ratio x stress in equivalent wood

The above procedure of course is not limited to the two materials treated above but applies well for any material combination. The wood and steel flitched beam was nearly chosen as a just for the sake of convenience.

Assumption

In order to analyze the behavior of composite beams, we first make the assumption that the materials are bonded rigidly together so that there can be no relative axial movement between them. This means that all the assumptions, which were valid for homogenous beams are valid except the one assumption that is no longer valid is that the Young's Modulus is the same throughout the beam.

The composite beams need not be made up of horizontal layers of materials as in the earlier example. For instance, a beam might have stiffening plates as shown in the figure below.

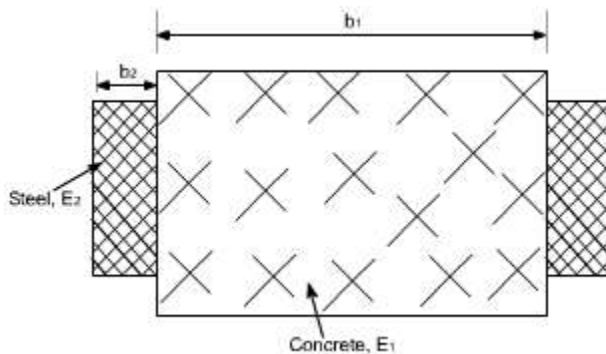

Again, the equivalent beam of the main beam material can be formed by scaling the breadth of the plate material in proportion to modular ratio. Bearing in mind that the strain at any level is same in both materials, the bending stresses in them are in proportion to the Young's modulus.

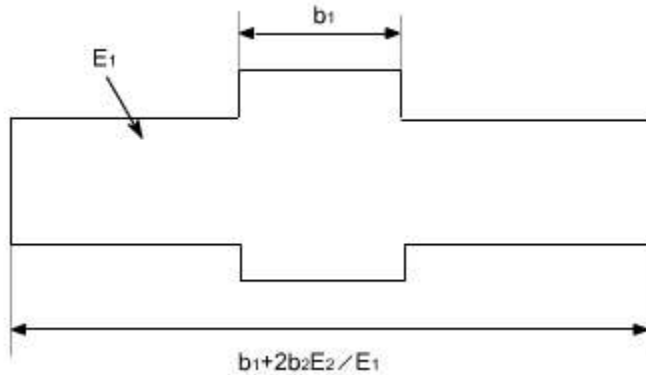

LECTURE 30 and 31

Deflection of Beams

Introduction:

In all practical engineering applications, when we use the different components, normally we have to operate them within the certain limits i.e. the constraints are placed on the performance and behavior of the components. For instance we say that the particular component is supposed to operate within this value of stress and the deflection of the component should not exceed beyond a particular value.

In some problems the maximum stress however, may not be a strict or severe condition but there may be the deflection which is the more rigid condition under operation. It is obvious therefore to study the methods by which we can predict the deflection of members under lateral loads or transverse loads, since it is this form of loading which will generally produce the greatest deflection of beams.

Assumption: The following assumptions are undertaken in order to derive a differential equation of elastic curve for the loaded beam

1. Stress is proportional to strain i.e. hooks law applies. Thus, the equation is valid only for beams that are not stressed beyond the elastic limit.
2. The curvature is always small.
3. Any deflection resulting from the shear deformation of the material or shear stresses is neglected.

It can be shown that the deflections due to shear deformations are usually small and hence can be ignored.

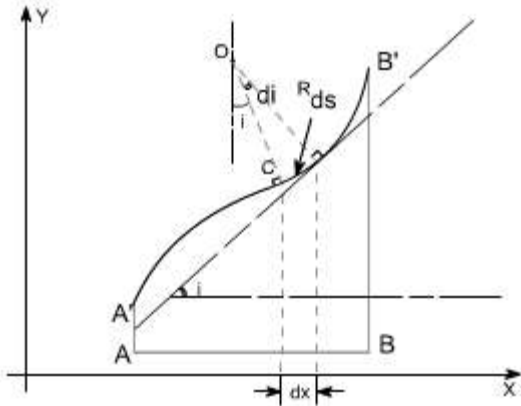

Consider a beam AB which is initially straight and horizontal when unloaded. If under the action of loads the beam deflects to a position A'B' under load or in fact we say that the axis of the beam bends to a shape A'B'. It is customary to call A'B' the curved axis of the beam as the elastic line or deflection curve.

In the case of a beam bent by transverse loads acting in a plane of symmetry, the bending moment M varies along the length of the beam and we represent the variation of bending moment in B.M diagram. Further, it is assumed that the simple bending theory equation holds good.

$$\frac{\sigma}{y} = \frac{M}{I} = \frac{E}{R}$$

If we look at the elastic line or the deflection curve, this is obvious that the curvature at every point is different; hence the slope is different at different points.

To express the deflected shape of the beam in rectangular co-ordinates let us take two axes x and y, x-axis coincides with the original straight axis of the beam and the y-axis shows the deflection.

Further, let us consider an element ds of the deflected beam. At the ends of this element let us construct the normal which intersect at point O denoting the angle between these two normals as di

But for the deflected shape of the beam the slope i at any point C is defined,

$$\tan i = \frac{dy}{dx} \dots\dots(1) \text{ or } i = \frac{dy}{dx} \text{ Assuming } \tan i = i$$

Further

$$ds = R di$$

however,

$$ds = dx \text{ [usually for small curvature]}$$

Hence

$$ds = dx = R di$$

$$\text{or } \boxed{\frac{di}{dx} = \frac{1}{R}}$$

substituting the value of i , one get

$$\frac{d}{dx} \left(\frac{dy}{dx} \right) = \frac{1}{R} \text{ or } \frac{d^2 y}{dx^2} = \frac{1}{R}$$

From the simple bending theory

$$\frac{M}{I} = \frac{E}{R} \text{ or } M = \frac{EI}{R}$$

so the basic differential equation governing the deflection of beam is

$$\boxed{M = EI \frac{d^2 y}{dx^2}}$$

This is the differential equation of the elastic line for a beam subjected to bending in the plane of symmetry. Its solution $y = f(x)$ defines the shape of the elastic line or the deflection curve as it is frequently called.

Relationship between shear force, bending moment and deflection: The relationship among shear force, bending moment and deflection of the beam may be obtained as

Differentiating the equation as derived

$$\frac{dM}{dx} = EI \frac{d^3 y}{dx^3} \text{ Recalling } \frac{dM}{dx} = F$$

Thus,

$$F = EI \frac{d^3 y}{dx^3}$$

Therefore, the above expression represents the shear force whereas rate of intensity of loading can also be found out by differentiating the expression for shear force

$$\text{i.e } w = -\frac{dF}{dx}$$

$$w = -EI \frac{d^4y}{dx^4}$$

Therefore if 'y' is the deflection of the loaded beam, then the following important relations can be arrived at

$$\text{slope} = \frac{dy}{dx}$$

$$\text{B.M} = EI \frac{d^2y}{dx^2}$$

$$\text{Shear force} = EI \frac{d^3y}{dx^3}$$

$$\text{load distribution} = EI \frac{d^4y}{dx^4}$$

Methods for finding the deflection: The deflection of the loaded beam can be obtained various methods. The one of the method for finding the deflection of the beam is the direct integration method, i.e. the method using the differential equation which we have derived.

Direct integration method: The governing differential equation is defined as

$$M = EI \frac{d^2y}{dx^2} \quad \text{or} \quad \frac{M}{EI} = \frac{d^2y}{dx^2}$$

on integrating one get,

$$\frac{dy}{dx} = \int \frac{M}{EI} dx + A \quad \text{--- this equation gives the slope}$$

of the loaded beam.

Integrate once again to get the deflection.

$$y = \iint \frac{M}{EI} dx + Ax + B$$

Where A and B are constants of integration to be evaluated from the known conditions of slope and deflections for the particular value of x.

Illustrative examples : let us consider few illustrative examples to have a familiarity with the direct integration method

Case 1: Cantilever Beam with Concentrated Load at the end:- A cantilever beam is subjected to a concentrated load W at the free end, it is required to determine the deflection of the beam

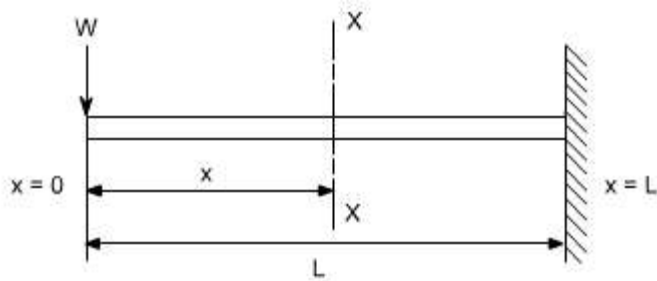

In order to solve this problem, consider any X-section X-X located at a distance x from the left end or the reference, and write down the expressions for the shear force and the bending moment

$$S.F|_{x-x} = -Wx$$

$$B.M|_{x-x} = -Wx \cdot x$$

$$\text{Therefore } M|_{x-x} = -Wx \cdot x$$

$$\text{the governing equation } \frac{M}{EI} = \frac{d^2 y}{dx^2}$$

substituting the value of M in terms of x then integrating the equation one get

$$\frac{M}{EI} = \frac{d^2 y}{dx^2}$$

$$\frac{d^2 y}{dx^2} = -\frac{Wx}{EI}$$

$$\int \frac{d^2 y}{dx^2} = \int -\frac{Wx}{EI} dx$$

$$\frac{dy}{dx} = -\frac{Wx^2}{2EI} + A$$

Integrating once more,

$$\int \frac{dy}{dx} = \int -\frac{Wx^2}{2EI} dx + \int A dx$$

$$y = -\frac{Wx^3}{6EI} + Ax + B$$

The constants A and B are required to be found out by utilizing the boundary conditions as defined below

$$\text{i.e at } x=L ; y=0 \quad \text{----- (1)}$$

$$\text{at } x=L ; dy/dx = 0 \quad \text{----- (2)}$$

Utilizing the second condition, the value of constant A is obtained as

$$A = \frac{wL^2}{2EI}$$

While employing the first condition yields

$$y = -\frac{wL^3}{6EI} + AL + B$$

$$\begin{aligned} B &= \frac{wL^3}{6EI} - AL \\ &= \frac{wL^3}{6EI} - \frac{wL^3}{2EI} \\ &= \frac{wL^3 - 3wL^3}{6EI} = -\frac{2wL^3}{6EI} \end{aligned}$$

$$B = -\frac{wL^3}{3EI}$$

Substituting the values of A and B we get

$$y = \frac{1}{EI} \left[-\frac{wx^3}{6EI} + \frac{wL^2x}{2EI} - \frac{wL^3}{3EI} \right]$$

The slope as well as the deflection would be maximum at the free end hence putting $x=0$ we get,

$$y_{\max} = -\frac{wL^3}{3EI}$$

$$(\text{Slope})_{\max} = +\frac{wL^2}{2EI}$$

Case 2: A Cantilever with Uniformly distributed Loads:- In this case the cantilever beam is subjected to U.d.l with rate of intensity varying w / length. The same procedure can also be adopted in this case

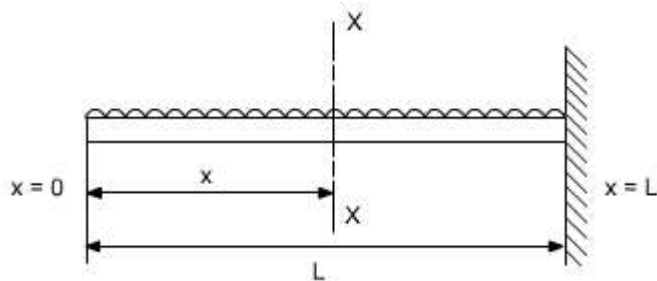

$$S.F|_{x-x} = -w$$

$$B.M|_{x-x} = -w \cdot x \cdot \frac{x}{2} = w \left(\frac{x^2}{2} \right)$$

$$\frac{M}{EI} = \frac{d^2 y}{dx^2}$$

$$\frac{d^2 y}{dx^2} = -\frac{wx^2}{2EI}$$

$$\int \frac{d^2 y}{dx^2} = \int -\frac{wx^2}{2EI} dx$$

$$\frac{dy}{dx} = -\frac{wx^3}{6EI} + A$$

$$\int \frac{dy}{dx} = \int -\frac{wx^3}{6EI} dx + \int A dx$$

$$y = -\frac{wx^4}{24EI} + Ax + B$$

Boundary conditions relevant to the problem are as follows:

1. At $x = L$; $y = 0$
2. At $x = L$; $dy/dx = 0$

The second boundary conditions yields

$$A = +\frac{wx^3}{6EI}$$

whereas the first boundary conditions yields

$$B = \frac{wL^4}{24EI} - \frac{wL^4}{6EI}$$

$$B = -\frac{wL^4}{8EI}$$

$$\text{Thus, } y = \frac{1}{EI} \left[-\frac{wx^4}{24} + \frac{wL^3 x}{6} - \frac{wL^4}{8} \right]$$

So y_{\max} will be at $x = 0$

$$y_{\max} = -\frac{wL^4}{8EI}$$

$$\left(\frac{dy}{dx} \right)_{\max} = \frac{wL^3}{6EI}$$

Case 3: Simply Supported beam with uniformly distributed Loads:- In this case a simply supported beam is subjected to a uniformly distributed load whose rate of intensity varies as w / length.

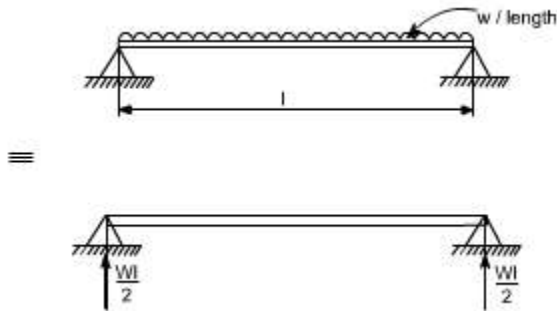

In order to write down the expression for bending moment consider any cross-section at distance of x metre from left end support.

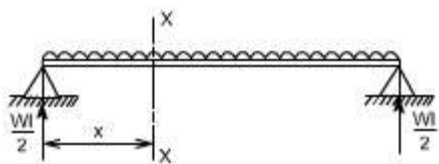

$$S.F|_{x-x} = w \left(\frac{l}{2} \right) - w \cdot x$$

$$B.M|_{x-x} = w \cdot \left(\frac{l}{2} \right) x - w \cdot x \cdot \left(\frac{x}{2} \right)$$

$$= \frac{wl \cdot x}{2} - \frac{wx^2}{2}$$

The differential equation which gives the elastic curve for the deflected beam is

$$\frac{d^2 y}{dx^2} = \frac{M}{EI} = \frac{1}{EI} \left[\frac{wl \cdot x}{2} - \frac{wx^2}{2} \right]$$

$$\frac{dy}{dx} = \int \frac{wlx}{2EI} dx - \int \frac{wx^2}{2EI} dx + A$$

$$= \frac{wlx^2}{4EI} - \frac{wx^3}{6EI} + A$$

Integrating, once more one gets

$$y = \frac{wlx^3}{12EI} - \frac{wx^4}{24EI} + A \cdot x + B \quad \text{----- (1)}$$

Boundary conditions which are relevant in this case are that the deflection at each support must be zero.

i.e. at $x = 0$; $y = 0$: at $x = l$; $y = 0$

let us apply these two boundary conditions on equation (1) because the boundary conditions are on y , This yields $B = 0$.

$$0 = \frac{wl^4}{12EI} - \frac{wl^4}{24EI} + A.l$$

$$A = -\frac{wl^3}{24EI}$$

So the equation which gives the deflection curve is

$$y = \frac{1}{EI} \left[\frac{wLx^3}{12} - \frac{wx^4}{24} - \frac{wL^3x}{24} \right]$$

Further

In this case the maximum deflection will occur at the centre of the beam where $x = L/2$ [i.e. at the position where the load is being applied]. So if we substitute the value of $x = L/2$

Then
$$y_{\max} = \frac{1}{EI} \left[\frac{wL}{12} \left(\frac{L^3}{8} \right) - \frac{w}{24} \left(\frac{L^4}{16} \right) - \frac{wL^3}{24} \left(\frac{L}{2} \right) \right]$$

$$y_{\max} = -\frac{5wL^4}{384EI}$$

Conclusions

- (i) The value of the slope at the position where the deflection is maximum would be zero.
- (ii) The value of maximum deflection would be at the centre i.e. at $x = L/2$.

The final equation which governs the deflection of the loaded beam in this case is

$$y = \frac{1}{EI} \left[\frac{wLx^3}{12} - \frac{wx^4}{24} - \frac{wL^3x}{24} \right]$$

By successive differentiation one can find the relations for slope, bending moment, shear force and rate of loading.

Deflection (y)

$$yEI = \left[\frac{wLx^3}{12} - \frac{wx^4}{24} - \frac{wL^3x}{24} \right]$$

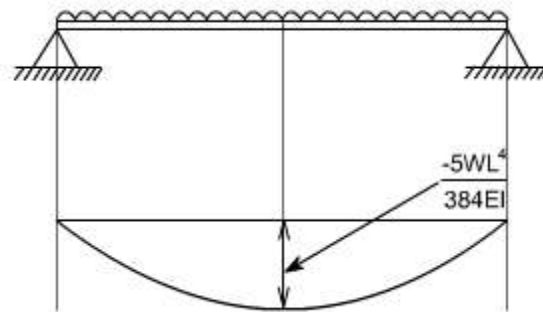

Slope (dy/dx)

$$EI \frac{dy}{dx} = \left[\frac{3wLx^2}{12} - \frac{4wx^3}{24} - \frac{wL^3}{24} \right]$$

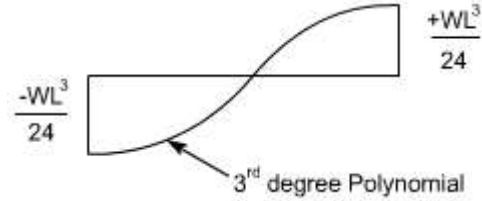

So the bending moment diagram would be

Bending Moment

$$\frac{d^2y}{dx^2} = \frac{1}{EI} \left[\frac{wLx}{2} - \frac{wx^2}{2} \right]$$

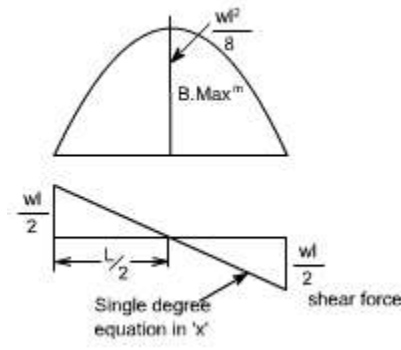

Shear Force

Shear force is obtained by taking third derivative.

$$EI \frac{d^3y}{dx^3} = \frac{wL}{2} - wx$$

Rate of intensity of loading

$$EI \frac{d^4y}{dx^4} = -w$$

Case 4: The direct integration method may become more involved if the expression for entire beam is not valid for the entire beam. Let us consider a deflection of a simply supported beam which is subjected to a concentrated load W acting at a distance 'a' from the left end.

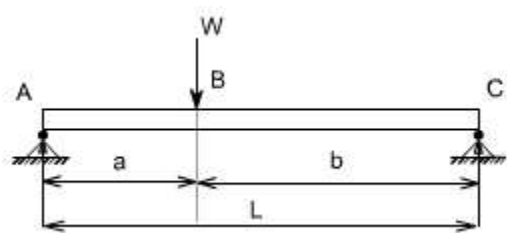

Let R_1 & R_2 be the reactions then,

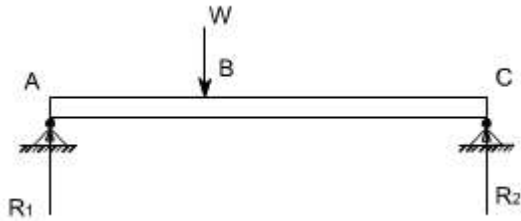

B.M for the portion AB

$$M|_{AB} = R_1 \cdot x \quad 0 \leq x \leq a$$

B.M for the portion BC

$$M|_{BC} = R_1 \cdot x - W(x - a) \quad a \leq x \leq l$$

so the differential equation for the two cases would be,

$$EI \frac{d^2 y}{dx^2} = R_1 \cdot x$$

$$EI \frac{d^2 y}{dx^2} = R_1 \cdot x - W(x - a)$$

These two equations can be integrated in the usual way to find 'y' but this will result in four constants of integration two for each equation. To evaluate the four constants of integration, four independent boundary conditions will be needed since the deflection of each support must be zero, hence the boundary conditions (a) and (b) can be realized.

Further, since the deflection curve is smooth, the deflection equations for the same slope and deflection at the point of application of load i.e. at $x = a$. Therefore four conditions required to evaluate these constants may be defined as follows:

- (a) at $x = 0$; $y = 0$ in the portion AB i.e. $0 \leq x \leq a$
- (b) at $x = l$; $y = 0$ in the portion BC i.e. $a \leq x \leq l$
- (c) at $x = a$; dy/dx , the slope is same for both portion
- (d) at $x = a$; y , the deflection is same for both portion

By symmetry, the reaction R_1 is obtained as

$$R_1 = \frac{Wb}{a+b}$$

Hence,

$$EI \frac{d^2 y}{dx^2} = \frac{Wb}{(a+b)} x \quad 0 \leq x \leq a \text{-----(1)}$$

$$EI \frac{d^2 y}{dx^2} = \frac{Wb}{(a+b)} x - W(x-a) \quad a \leq x \leq l \text{-----(2)}$$

integrating (1) and (2) we get,

$$EI \frac{dy}{dx} = \frac{Wb}{2(a+b)} x^2 + k_1 \quad 0 \leq x \leq a \text{-----(3)}$$

$$EI \frac{dy}{dx} = \frac{Wb}{2(a+b)} x^2 - \frac{W(x-a)^2}{2} + k_2 \quad a \leq x \leq l \text{-----(4)}$$

Using condition (c) in equation (3) and (4) shows that these constants should be equal, hence letting

$$K_1 = K_2 = K$$

Hence

$$EI \frac{dy}{dx} = \frac{Wb}{2(a+b)} x^2 + k \quad 0 \leq x \leq a \text{-----(3)}$$

$$EI \frac{dy}{dx} = \frac{Wb}{2(a+b)} x^2 - \frac{W(x-a)^2}{2} + k \quad a \leq x \leq l \text{-----(4)}$$

Integrating again equation (3) and (4) we get

$$EI y = \frac{Wb}{6(a+b)} x^3 + kx + k_3 \quad 0 \leq x \leq a \text{-----(5)}$$

$$EI y = \frac{Wb}{6(a+b)} x^3 - \frac{W(x-a)^3}{6} + kx + k_4 \quad a \leq x \leq l \text{-----(6)}$$

Utilizing condition (a) in equation (5) yields

$$k_3 = 0$$

Utilizing condition (b) in equation (6) yields

$$0 = \frac{Wb}{6(a+b)} l^3 - \frac{W(l-a)^3}{6} + kl + k_4$$

$$k_4 = -\frac{Wb}{6(a+b)} l^3 + \frac{W(l-a)^3}{6} - kl$$

But $a+b=l$,

Thus,

$$k_4 = -\frac{Wb(a+b)^2}{6} + \frac{Wb^3}{6} - k(a+b)$$

Now lastly k_3 is found out using condition (d) in equation (5) and equation (6), the

condition (d) is that,

At $x = a$; y ; the deflection is the same for both portion

Therefore $y|_{\text{from equation 5}} = y|_{\text{from equation 6}}$
or

$$\frac{Wb}{6(a+b)}x^3 + kx + k_3 = \frac{Wb}{6(a+b)}x^3 - \frac{W(x-a)^3}{6} + kx + k_4$$

$$\frac{Wb}{6(a+b)}a^3 + ka + k_3 = \frac{Wb}{6(a+b)}a^3 - \frac{W(a-a)^3}{6} + ka + k_4$$

Thus, $k_4 = 0$;

OR

$$k_4 = -\frac{Wb(a+b)^2}{6} + \frac{Wb^3}{6} - k(a+b) = 0$$

$$k(a+b) = -\frac{Wb(a+b)^2}{6} + \frac{Wb^3}{6}$$

$$k = -\frac{Wb(a+b)}{6} + \frac{Wb^3}{6(a+b)}$$

so the deflection equations for each portion of the beam are

$$Ely = \frac{Wb}{6(a+b)}x^3 + kx + k_3$$

$$Ely = \frac{Wbx^3}{6(a+b)} - \frac{Wb(a+b)x}{6} + \frac{Wb^3x}{6(a+b)} \quad \text{-----for } 0 \leq x \leq a \text{----- (7)}$$

and for other portion

$$Ely = \frac{Wb}{6(a+b)}x^3 - \frac{W(x-a)^3}{6} + kx + k_4$$

Substituting the value of 'k' in the above equation

$$Ely = \frac{Wbx^3}{6(a+b)} - \frac{W(x-a)^3}{6} - \frac{Wb(a+b)x}{6} + \frac{Wb^3x}{6(a+b)} \quad \text{For } a \leq x \leq l \text{----- (8)}$$

so either of the equation (7) or (8) may be used to find the deflection at $x = a$

hence substituting $x = a$ in either of the equation we get

$$Y|_{x=a} = -\frac{Wa^2b^2}{3EI(a+b)}$$

OR if $a = b = l/2$

$$Y_{\text{max}} = -\frac{WL^3}{48EI}$$

ALTERNATE METHOD: There is also an alternative way to attempt this problem in a more simpler way. Let us considering the origin at the point of application of the load,

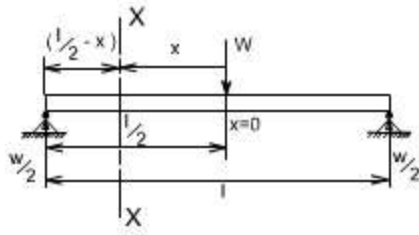

$$S.F|_{xx} = \frac{W}{2}$$

$$B.M|_{xx} = \frac{W}{2} \left(\frac{l}{2} - x \right)$$

substituting the value of M in the governing equation for the deflection

$$\frac{d^2 y}{dx^2} = \frac{W}{2} \left(\frac{l}{2} - x \right)$$

$$\frac{dy}{dx} = \frac{1}{EI} \left[\frac{WLx}{4} - \frac{Wx^2}{4} \right] + A$$

$$y = \frac{1}{EI} \left[\frac{WLx^2}{8} - \frac{Wx^3}{12} \right] + Ax + B$$

Boundary conditions relevant for this case are as follows

(i) at $x = 0$; $dy/dx = 0$

hence, $A = 0$

(ii) at $x = l/2$; $y = 0$ (because now $l/2$ is on the left end or right end support since we have taken the origin at the centre)

Thus,

$$0 = \left[\frac{WL^3}{32} - \frac{WL^3}{96} + B \right]$$

$$B = -\frac{WL^3}{48}$$

Hence the equation which governs the deflection would be

$$y = \frac{1}{EI} \left[\frac{WLx^2}{8} - \frac{Wx^3}{12} - \frac{WL^3}{48} \right]$$

Hence

$Y_{\max}^m _{at\ x=0} = -\frac{WL^3}{48EI}$	At the centre
$\left(\frac{dy}{dx} \right)_{\max}^m _{at\ x=\pm \frac{L}{2}} = \pm \frac{WL^2}{16EI}$	At the ends

Hence the integration method may be bit cumbersome in some of the case. Another limitation of the method would be that if the beam is of non uniform cross section,

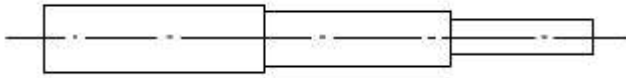

i.e. it is having different cross-section then this method also fails.

So there are other methods by which we find the deflection like

1. Macaulay's method in which we can write the different equation for bending moment for different sections.
2. Area moment methods
3. Energy principle methods

LECTURE 32

THE AREA-MOMENT / MOMENT-AREA METHODS:

The area moment method is a semi graphical method of dealing with problems of deflection of beams subjected to bending. The method is based on a geometrical interpretation of definite integrals. This is applied to cases where the equation for bending moment to be written is cumbersome and the loading is relatively simple.

Let us recall the figure, which we referred while deriving the differential equation governing the beams.

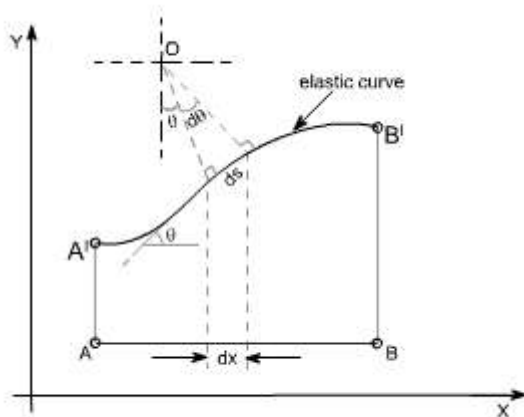

It may be noted that $d\theta$ is an angle subtended by an arc element ds and M is the bending moment to which this element is subjected.

We can assume,

$$ds = dx \text{ [since the curvature is small]}$$

$$\text{hence, } R d\theta = ds$$

$$\frac{d\theta}{ds} = \frac{1}{R} = \frac{M}{EI}$$

$$\frac{d\theta}{ds} = \frac{M}{EI}$$

But for small curvature [but θ is the angle, slope is $\tan\theta = \frac{dy}{dx}$ for small

angles $\tan\theta \approx \theta$, hence $\theta \approx \frac{dy}{dx}$ so we get $\frac{d^2y}{dx^2} = \frac{M}{EI}$ by putting $ds \approx dx$]

Hence,

$$\frac{d\theta}{dx} = \frac{M}{EI} \text{ or } \boxed{d\theta = \frac{M \cdot dx}{EI}} \text{ ----- (1)}$$

The relationship as described in equation (1) can be given a very simple graphical interpretation with reference to the elastic plane of the beam and its bending moment diagram

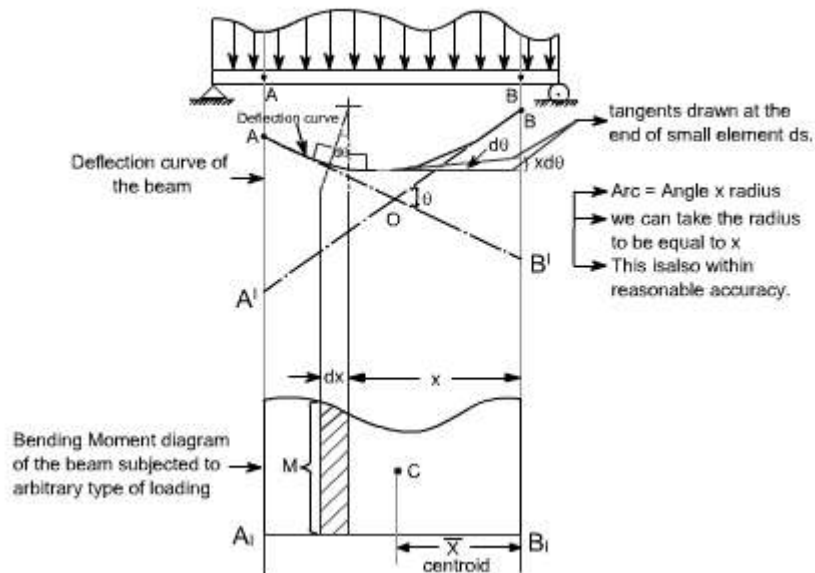

Refer to the figure shown above consider AB to be any portion of the elastic line of the loaded beam and A_1B_1 is its corresponding bending moment diagram.

Let $AO =$ Tangent drawn at A

BO = Tangent drawn at B

Tangents at A and B intersect at the point O.

Further, AA' is the deflection of A away from the tangent at B while the vertical distance B'B is the deflection of point B away from the tangent at A. All these quantities are further understood to be very small.

Let $ds \approx dx$ be any element of the elastic line at a distance x from B and an angle between its tangents be dq . Then, as derived earlier

$$d\theta = \frac{M \cdot dx}{EI}$$

This relationship may be interpreted as that this angle is nothing but the area $M \cdot dx$ of the shaded bending moment diagram divided by EI .

From the above relationship the total angle q between the tangents A and B may be determined as

$$\theta = \int_A^B \frac{M dx}{EI} = \frac{1}{EI} \int_A^B M dx$$

Since this integral represents the total area of the bending moment diagram, hence we may conclude this result in the following theorem

Theorem I:

$$\left\{ \begin{array}{l} \text{slope or } \theta \\ \text{between any two points} \end{array} \right\} = \left\{ \begin{array}{l} \frac{1}{EI} \times \text{area of B.M diagram between} \\ \text{corresponding portion of B.M diagram} \end{array} \right\}$$

Now let us consider the deflection of point B relative to tangent at A, this is nothing but the vertical distance BB'. It may be noted from the bending diagram that bending of the element ds contributes to this deflection by an amount equal to $x dq$ [each of this intercept may be considered as the arc of a circle of radius x subtended by the angle q]

$$\delta = \int_A^B x d\theta$$

Hence the total distance B'B becomes

The limits from A to B have been taken because A and B are the two points on the elastic curve, under consideration]. Let us substitute the value of $dq = M dx / EI$ as derived earlier

$$\delta = \int_A^B x \frac{M dx}{EI} = \int_A^B \frac{M dx}{EI} \cdot x$$

[This is infact the moment of area of the bending moment diagram]

Since $M dx$ is the area of the shaded strip of the bending moment diagram and x is its distance from B, we therefore conclude that right hand side of the above equation represents first moment area with respect to B of the total bending moment area between A and B divided by EI.

Therefore, we are in a position to state the above conclusion in the form of theorem as follows:

Theorem II:

Deflection of point 'B' relative to point A $= \frac{1}{EI} \times \left\{ \begin{array}{l} \text{first moment of area with respect} \\ \text{to point B, of the total B.M diagram} \end{array} \right\}$

Further, the first moment of area, according to the definition of centroid may be written as $A \bar{x}$, where \bar{x} is equal to distance of centroid and a is the total area of bending moment

Thus, $\delta_A = \frac{1}{EI} A \bar{x}$

Therefore, the first moment of area may be obtained simply as a product of the total area of the B.M diagram between the points A and B multiplied by the distance \bar{x} to its centroid C.

If there exists an inflection point or point of contreflexure for the elastic line of the loaded beam between the points A and B, as shown below,

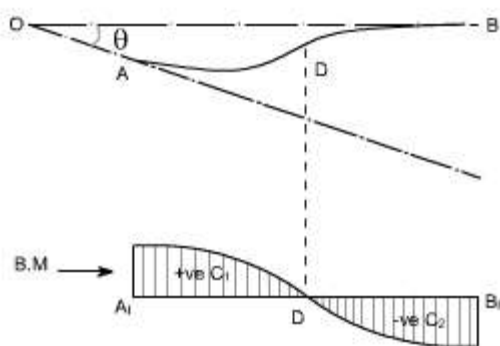

Then, adequate precaution must be exercised in using the above theorem. In such a case B. M diagram gets divide into two portions +ve and -ve portions with centroids C_1 and C_2 . Then to find an angle θ between the tangents at the points A and B

$$\theta = \int_A^D \frac{M dx}{EI} - \int_D^B \frac{M dx}{EI}$$

And similarly for the deflection of B away from the tangent at A becomes

$$\delta = \int_A^D \frac{M dx}{EI} \cdot x - \int_D^B \frac{M dx}{EI} \cdot x$$

Illustrative Examples: Let us study few illustrative examples, pertaining to the use of these theorems

Example 1:

1. A cantilever is subjected to a concentrated load at the free end. It is required to find out the deflection at the free end.

For a cantilever beam, the bending moment diagram may be drawn as shown below

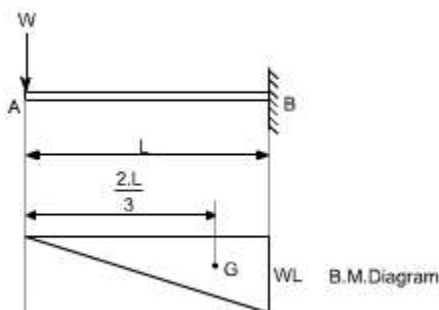

Let us work out this problem from the zero slope condition and apply the first area - moment theorem

$$\begin{aligned} \text{slope at A} &= \frac{1}{EI} [\text{Area of B.M diagram between the points A and B}] \\ &= \frac{1}{EI} \left[\frac{1}{2} L \cdot WL \right] \\ &= \frac{WL^2}{2EI} \end{aligned}$$

The deflection at A (relative to B) may be obtained by applying the second area - moment theorem

NOTE: In this case the point B is at zero slope.

Thus,

$$\begin{aligned} \delta &= \frac{1}{EI} [\text{first moment of area of B.M diagram between A and B about A}] \\ &= \frac{1}{EI} [A\bar{y}] \\ &= \frac{1}{EI} \left[\left(\frac{1}{2} L \cdot WL \right) \frac{2}{3} L \right] \\ &= \frac{WL^3}{3EI} \end{aligned}$$

Example 2: Simply supported beam is subjected to a concentrated load at the mid span determine the value of deflection.

A simply supported beam is subjected to a concentrated load W at point C . The bending moment diagram is drawn below the loaded beam.

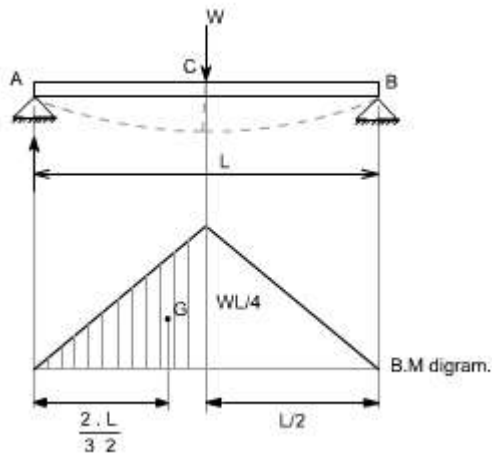

Again working relative to the zero slope at the centre C .

slope at A = $\frac{1}{EI}$ [Area of B. M diagram between A and C]

$$= \frac{1}{EI} \left[\left(\frac{1}{2} \right) \left(\frac{L}{2} \right) \left(\frac{WL}{4} \right) \right]$$

we are taking half area of the B.M because we have to work out this relative to a zero slope

$$= \frac{WL^2}{16EI}$$

Deflection of A relative to C = central deflection of C
or

$$\delta_C = \frac{1}{EI} [\text{Moment of B.M diagram between points A and C about A}]$$

$$= \frac{1}{EI} \left[\left(\frac{1}{2} \right) \left(\frac{L}{2} \right) \left(\frac{WL}{4} \right) \frac{2}{3} L \right]$$

$$= \frac{WL^3}{48EI}$$

Example 3: A simply supported beam is subjected to a uniformly distributed load, with a intensity of loading W / length . It is required to determine the deflection.

The bending moment diagram is drawn, below the loaded beam, the value of maximum B.M is equal to $WL^2 / 8$

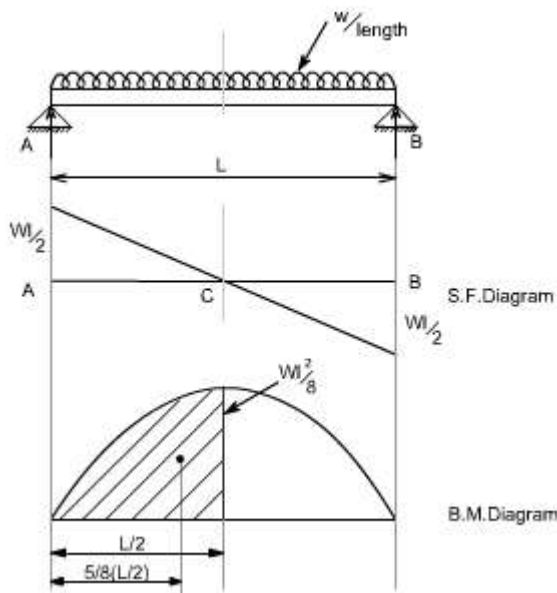

So by area moment method,

$$\begin{aligned} \text{Slope at point C w.r.t point A} &= \frac{1}{EI} [\text{Area of B.M diagram between point A and C}] \\ &= \frac{1}{EI} \left[\left(\frac{2}{3} \right) \left(\frac{WL^2}{8} \right) \left(\frac{L}{2} \right) \right] \\ &= \frac{WL^3}{24EI} \end{aligned}$$

$$\text{Deflection at point C} = \frac{1}{EI} [A \bar{y}]$$

relative to A

$$\begin{aligned} &= \frac{1}{EI} \left[\left(\frac{WL^3}{24} \right) \left(\frac{5}{8} \right) \left(\frac{L}{2} \right) \right] \\ &= \frac{5}{384EI} \cdot WL^4 \end{aligned}$$

LECTURE 33

Macaulay's Methods

If the loading conditions change along the span of beam, there is corresponding change in moment equation. This requires that a separate moment equation be written between each change of load point and that two integration be made for each such moment equation. Evaluation of the constants introduced by each integration can become very involved. Fortunately, these complications can be avoided by writing single moment equation in such a way that it becomes continuous for entire length of the beam in spite of the discontinuity of loading.

Note : In Macaulay's method some author's take the help of unit function approximation (i.e. Laplace transform) in order to illustrate this method, however both are essentially the same.

For example consider the beam shown in fig below:

Let us write the general moment equation using the definition $M = (\sum M)_L$, Which means that we consider the effects of loads lying on the left of an exploratory section. The moment equations for the portions AB, BC and CD are written as follows

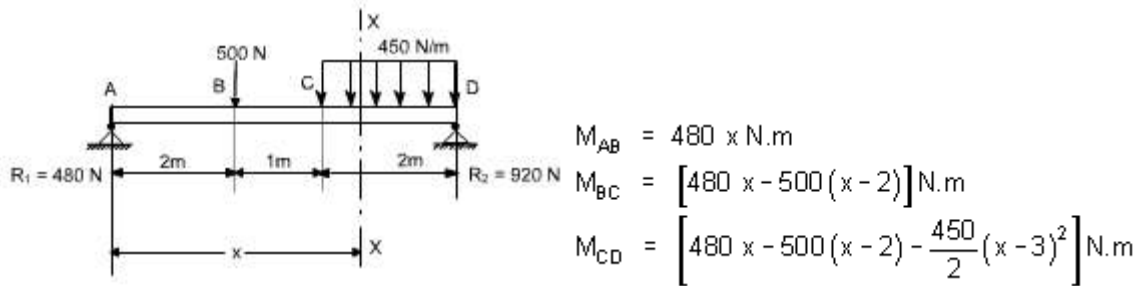

It may be observed that the equation for M_{CD} will also be valid for both M_{AB} and M_{BC} provided that the terms $(x - 2)$ and $(x - 3)^2$ are neglected for values of x less than 2 m and 3 m, respectively. In other words, the terms $(x - 2)$ and $(x - 3)^2$ are nonexistent for values of x for which the terms in parentheses are negative.

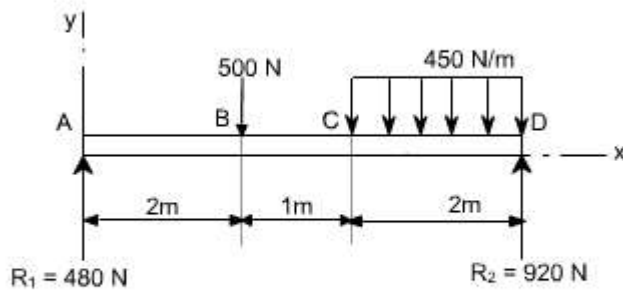

As a clear indication of these restrictions, one may use a nomenclature in which the usual form of parentheses is replaced by pointed brackets, namely, $\langle \rangle$. With this change in nomenclature, we obtain a single moment equation

$$M = \left(480x - 500 \langle x - 2 \rangle - \frac{450}{2} \langle x - 3 \rangle^2 \right) \text{ N.m}$$

Which is valid for the entire beam if we postulate that the terms between the pointed brackets do not exist for negative values; otherwise the term is to be treated like any ordinary expression.

As another example, consider the beam as shown in the fig below. Here the distributed load extends only over the segment BC. We can create continuity, however, by assuming that the distributed load extends beyond C and adding an equal upward-distributed load to cancel its effect beyond C, as shown in the adjacent fig below. The general moment equation, written for the last segment DE in the new nomenclature may be written as:

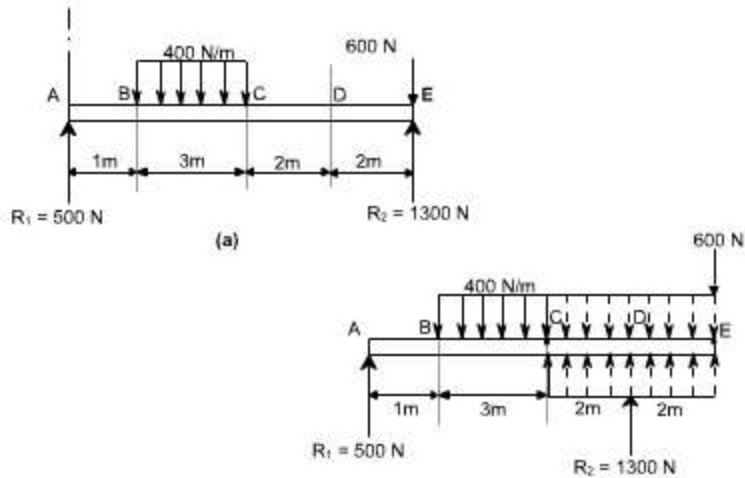

$$M = \left(500x - \frac{400}{2}(x-1)^2 + \frac{400}{2}(x-4)^2 + 1300(x-6) \right) \text{N.m}$$

It may be noted that in this equation effect of load 600 N won't appear since it is just at the last end of the beam so if we assume the exploratory just at section at just the point of application of 600 N than $x = 0$ or else we will here take the X - section beyond 600 N which is invalid.

Procedure to solve the problems

- (i). After writing down the moment equation which is valid for all values of 'x' i.e. containing pointed brackets, integrate the moment equation like an ordinary equation.
- (ii). While applying the B.C's keep in mind the necessary changes to be made regarding the pointed brackets.

Illustrative Examples :

1. A concentrated load of 300 N is applied to the simply supported beam as shown in Fig. Determine the equations of the elastic curve between each change of load point and the maximum deflection in the beam.

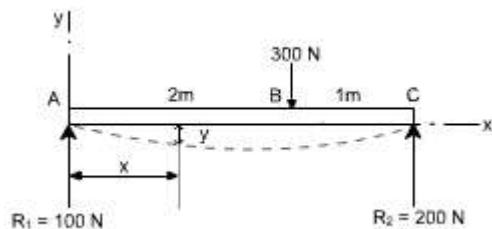

Solution : writing the general moment equation for the last portion BC of the loaded beam,

$$EI \frac{d^2 y}{dx^2} = M = (100x - 300(x - 2)) \text{ N.m} \quad \dots\dots(1)$$

Integrating twice the above equation to obtain slope and the deflection

$$EI \frac{dy}{dx} = (50x^2 - 150(x - 2)^2 + C_1) \text{ N.m}^2 \quad \dots\dots(2)$$

$$EI y = \left(\frac{50}{3} x^3 - 50(x - 2)^3 + C_1 x + C_2 \right) \text{ N.m}^3 \quad \dots\dots(3)$$

To evaluate the two constants of integration. Let us apply the following boundary conditions:

1. At point A where $x = 0$, the value of deflection $y = 0$. Substituting these values in Eq. (3) we find $C_2 = 0$. keep in mind that $\langle x - 2 \rangle^3$ is to be neglected for negative values.

2. At the other support where $x = 3\text{m}$, the value of deflection y is also zero.

substituting these values in the deflection Eq. (3), we obtain

$$0 = \left(\frac{50}{3} 3^3 - 50(3 - 2)^3 + 3.C_1 \right) \text{ or } C_1 = -133 \text{ N.m}^2$$

Having determined the constants of integration, let us make use of Eqs. (2) and (3) to rewrite the slope and deflection equations in the conventional form for the two portions.

segment AB ($0 \leq x \leq 2\text{m}$)

$$EI \frac{dy}{dx} = (50x^2 - 133) \text{ N.m}^2 \quad \dots\dots(4)$$

$$EI y = \left(\frac{50}{3} x^3 - 133x \right) \text{ N.m}^3 \quad \dots\dots(5)$$

segment BC ($2\text{m} \leq x \leq 3\text{m}$)

$$EI \frac{dy}{dx} = (50x^2 - 150(x - 2)^2 - 133x) \text{ N.m}^2 \quad \dots\dots(6)$$

$$EI y = \left(\frac{50}{3} x^3 - 50(x - 2)^3 - 133x \right) \text{ N.m}^3 \quad \dots\dots(7)$$

Continuing the solution, we assume that the maximum deflection will occur in the segment AB. Its location may be found by differentiating Eq. (5) with respect to x and setting the derivative to be equal to zero, or, what amounts to the same thing, setting the slope equation (4) equal to zero and solving for the point of zero slope.

We obtain

$50x^2 - 133 = 0$ or $x = 1.63$ m (It may be kept in mind that if the solution of the equation does not yield a value < 2 m then we have to try the other equations which are valid for segment BC)

Since this value of x is valid for segment AB, our assumption that the maximum deflection occurs in this region is correct. Hence, to determine the maximum deflection, we substitute $x = 1.63$ m in Eq (5), which yields

$$EIy|_{\text{max}} = -145 \text{ N.m}^3 \quad \dots\dots(8)$$

The negative value obtained indicates that the deflection y is downward from the x axis. quite usually only the magnitude of the deflection, without regard to sign, is desired; this is denoted by d , the use of y may be reserved to indicate a directed value of deflection.

if $E = 30$ Gpa and $I = 1.9 \times 10^6 \text{ mm}^4 = 1.9 \times 10^{-6} \text{ m}^4$, Eq. (h) becomes

$$y|_{\text{max}} = \frac{-145}{EI} = \frac{-145}{(30 \times 10^9)(1.9 \times 10^{-6})}$$

Then $y|_{\text{max}} = -2.54 \text{ mm}$

Example 2:

It is required to determine the value of EIy at the position midway between the supports and at the overhanging end for the beam shown in figure below.

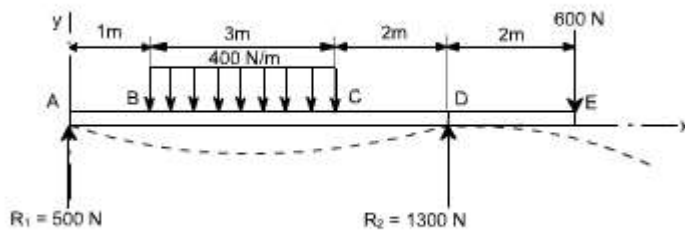

Solution:

Writing down the moment equation which is valid for the entire span of the beam and applying the differential equation of the elastic curve, and integrating it twice, we obtain

$$EI \frac{d^2y}{dx^2} = M = \left(500x - \frac{400}{2}(x-1)^2 + \frac{400}{2}(x-4)^2 + 1300(x-6) \right) \text{N.m}$$

$$EI \frac{dy}{dx} = \left(250x^2 - \frac{200}{3}(x-1)^3 + \frac{200}{3}(x-4)^3 + 650(x-6)^2 + C_1 \right) \text{N.m}$$

$$EIy = \left(\frac{250}{3}x^3 - \frac{50}{3}(x-1)^4 + \frac{50}{3}(x-4)^4 + \frac{650}{3}(x-6)^3 + C_1x + C_2 \right) \text{N.m}^3$$

To determine the value of C_2 , It may be noted that $EIy = 0$ at $x = 0$, which gives $C_2 = 0$. Note that the negative terms in the pointed brackets are to be ignored. Next, let us use the condition that $EIy = 0$ at the right support where $x = 6\text{m}$. This gives

$$0 = \frac{250}{3}(6)^3 - \frac{50}{3}(5)^4 + \frac{50}{3}(2)^4 + 6C_1 \text{ or } C_1 = -1308 \text{N.m}^2$$

Finally, to obtain the midspan deflection, let us substitute the value of $x = 3\text{m}$ in the deflection equation for the segment BC obtained by ignoring negative values of the bracketed terms $(x-4)^4$ and $(x-6)^3$. We obtain

$$EIy = \frac{250}{3}(3)^3 - \frac{50}{3}(2)^4 - 1308(3) = -1941 \text{N.m}^3$$

For the overhanging end where $x=8\text{m}$, we have

$$EIy = \left(\frac{250}{3}(8)^3 - \frac{50}{3}(7)^4 + \frac{50}{3}(4)^4 + \frac{650}{3}(2)^3 - 1308(8) \right)$$

$$= -1814 \text{N.m}^3$$

Example 3:

A simply supported beam carries the triangularly distributed load as shown in figure. Determine the deflection equation and the value of the maximum deflection.

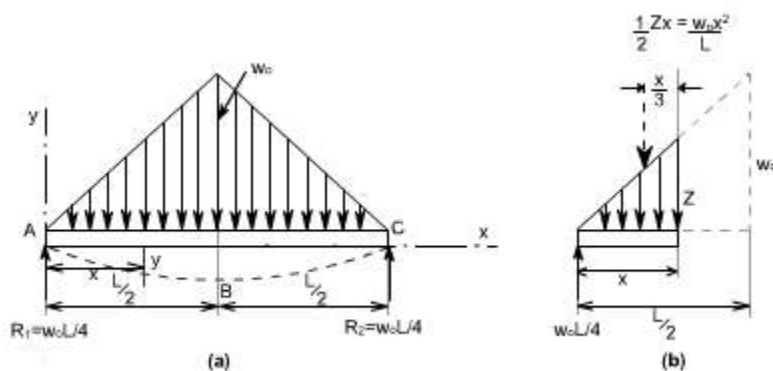

Solution:

Due to symmetry, the reactions are one half the total load of $1/2w_0L$, or $R_1 = R_2 =$

$1/4w_0L$. Due to the advantage of symmetry to the deflection curve from A to B is the mirror image of that from C to B. The condition of zero deflection at A and of zero slope at B do not require the use of a general moment equation. Only the moment equation for segment AB is needed, and this may be easily written with the aid of figure(b).

Taking into account the differential equation of the elastic curve for the segment AB and integrating twice, one can obtain

$$EI \frac{d^2y}{dx^2} = M_{AB} = \frac{w_0L}{4}x - \frac{w_0x^2}{L} \cdot \frac{x}{3} \quad \dots\dots(1)$$

$$EI \frac{dy}{dx} = \frac{w_0Lx^2}{8} - \frac{w_0x^4}{12L} + C_1 \quad \dots\dots(2)$$

$$EIy = \frac{w_0Lx^3}{24} - \frac{w_0x^5}{60L} + C_1x + C_2 \dots\dots(3)$$

In order to evaluate the constants of integration, let us apply the B.C's we note that at the support A, $y = 0$ at $x = 0$. Hence from equation (3), we get $C_2 = 0$. Also, because of symmetry, the slope $dy/dx = 0$ at midspan where $x = L/2$. Substituting these conditions in equation (2) we get

$$0 = \frac{w_0L}{8} \left(\frac{L}{2}\right)^2 - \frac{w_0}{12L} \left(\frac{L}{2}\right)^4 + C_1 \cdot C_1 = -\frac{5w_0L^3}{192}$$

Hence the deflection equation from A to B (and also from C to B because of symmetry) becomes

$$EIy = \frac{w_0Lx^3}{24} - \frac{w_0x^5}{60L} - \frac{5w_0L^3x}{192}$$

Which reduces to

$$EIy = -\frac{w_0x}{960L} (25L^4 - 40L^2x^2 + 16x^4)$$

The maximum deflection at midspan, where $x = L/2$ is then found to be

$$EIy = -\frac{w_0L^4}{120}$$

Example 4: couple acting

Consider a simply supported beam which is subjected to a couple M at a distance 'a' from the left end. It is required to determine using the Macauley's method.

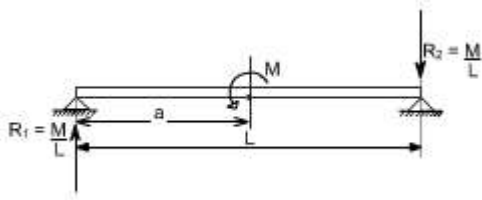

To deal with couples, only thing to remember is that within the pointed brackets we have to take some quantity and this should be raised to the power zero. i.e. $M \langle x - a \rangle^0$. We have taken the power 0 (zero) because ultimately the term $M \langle x - a \rangle^0$ should have the moment units. Thus with integration the quantity $\langle x - a \rangle^0$ becomes either $\langle x - a \rangle^1$ or $\langle x - a \rangle^2$

Or

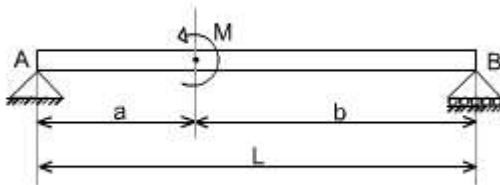

Therefore, writing the general moment equation we get

$$M = R_1 x - M \langle x - a \rangle \text{ or } EI \frac{d^2 y}{dx^2} = M$$

Integrating twice we get

$$EI \frac{dy}{dx} = R_1 \cdot \frac{x^2}{2} - M \langle x - a \rangle^1 + C_1$$

$$EI y = R_1 \cdot \frac{x^3}{6} - \frac{M}{2} \langle x - a \rangle^2 + C_1 x + C_2$$

Example 5:

A simply supported beam is subjected to U.d.l in combination with couple M. It is required to determine the deflection.

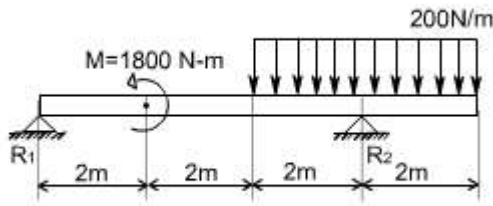

This problem may be attempted in the some way. The general moment equation may be written as

$$M(x) = R_1 x - 1800 \langle x - 2 \rangle^0 - \frac{200 \langle x - 4 \rangle \langle x - 4 \rangle}{2} + R_2 \langle x - 6 \rangle$$

$$= R_1 x - 1800 \langle x - 2 \rangle^0 - \frac{200 \langle x - 4 \rangle^2}{2} + R_2 \langle x - 6 \rangle$$

Thus,

$$EI \frac{d^2 y}{dx^2} = R_1 x - 1800 \langle x - 2 \rangle^0 - \frac{200 \langle x - 4 \rangle^2}{2} + R_2 \langle x - 6 \rangle$$

Integrate twice to get the deflection of the loaded beam.

LECTURE 34

Members Subjected to Combined Loads

Combined Bending & Twisting : In some applications the shaft are simultaneously subjected to bending moment M and Torque T . The Bending moment comes on the shaft due to gravity or Inertia loads. So the stresses are set up due to bending moment and Torque.

For design purposes it is necessary to find the principal stresses, maximum shear stress, which ever is used as a criterion of failure.

$$\frac{\sigma}{y} = \frac{M}{I} = \frac{E}{R}$$

From the simple bending theory equation

If σ_b is the maximum bending stresses due to bending.

$$\sigma_b = \frac{M \cdot y}{I}$$

$$\sigma_b |_{\max} = \frac{M}{I} \cdot y_{\max}$$

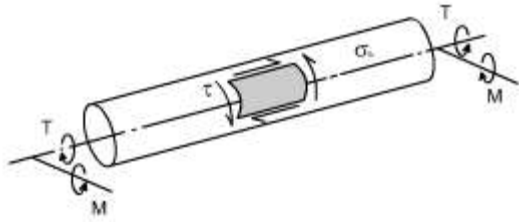

For the case of circular shafts y_{\max}^m – equal to $d/2$ since y is the distance from the neutral axis.

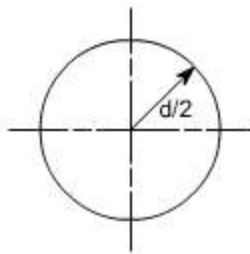

I is the moment of inertia for circular shafts

$$I = \pi d^4 / 64$$

Hence then, the maximum bending stresses developed due to the application of bending moment M is

$$\begin{aligned} \sigma_b |_{\max} &= \frac{M}{\pi d^4 / 64} \cdot \frac{d}{2} \\ \sigma_b |_{\max} &= \frac{32M}{\pi d^3} \quad (1) \end{aligned}$$

From the torsion theory, the maximum shear stress on the surface of the shaft is given by the torsion equation

$$\begin{aligned} \frac{T}{J} &= \frac{\tau'}{r} = \frac{G \cdot \theta}{L} \\ \Rightarrow \frac{\tau'}{r} &= \frac{T}{J} \end{aligned}$$

Where τ' is the shear stress at any radius r but when the maximum value is desired the value of r should be maximum and the value of r is maximum at $r = d/2$

Thus $\tau_{\max} = \frac{T}{J} \cdot \frac{d}{2}$
 $J = \frac{\pi d^4}{32}$

substituting the value of J, we get

$$\tau_{\max} = \frac{16T}{\pi d^3} \quad (2)$$

The nature of the shear stress distribution is shown below :

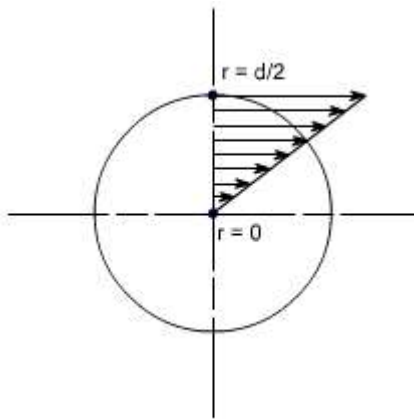

This can now be treated as the two – dimensional stress system in which the loading in a vertical plane is zero i.e. $s_y = 0$ and $s_x = s_b$ and is shown below :

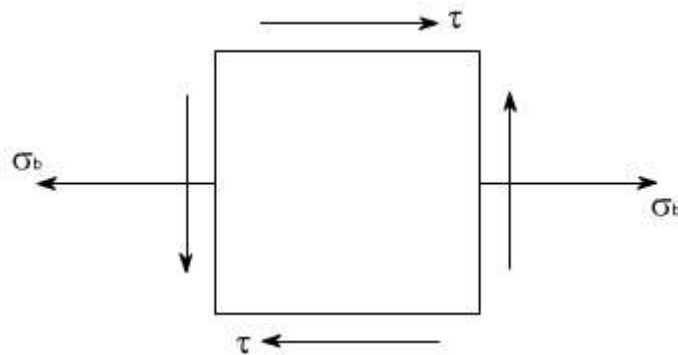

Thus, the principle stresses may be obtained as

$$\sigma_1, \sigma_2 = \left(\frac{\sigma_x + \sigma_y}{2} \right) \pm \frac{1}{2} \sqrt{(\sigma_x - \sigma_y)^2 + 4\tau_{xy}^2}$$

or

$$\begin{aligned} \sigma_1 &= \frac{\sigma_b}{2} + \frac{1}{2} \sqrt{\sigma_b^2 + 4\tau_{\max}^2} \\ &= \frac{32M}{\pi d^3 \cdot 2} + \frac{1}{2} \sqrt{\left(\frac{32M}{\pi d^3} \right)^2 + 4 \left(\frac{16T}{\pi d^3} \right)^2} \\ &= \frac{16M}{\pi d^3 \cdot 2} + \frac{1}{2} \sqrt{\left(\frac{32M}{\pi d^3} \right)^2 + \left(\frac{2 \cdot 16T}{\pi d^3} \right)^2} \\ &= \frac{16}{\pi d^3} \left[M + \sqrt{M^2 + T^2} \right] \end{aligned}$$

Equivalent Bending Moment :

Now let us define the term the equivalent bending moment which acting alone, will produce the same maximum principal stress or bending stress. Let M_e be the equivalent bending moment, then due to bending

$$\sigma_1 = \frac{32M_e}{\pi d^3}$$

Further

$$\sigma_1 = \frac{16}{\pi d^3} \left[M + \sqrt{M^2 + T^2} \right]$$

Thus, equating the two we get

$$\boxed{M_e = \frac{1}{2} \left[M + \sqrt{M^2 + T^2} \right]}$$

Equivalent Torque :

At we here already proved that s_1 and s_2 for the combined bending and twisting case are expressed by the relations:

$$\sigma_1, \sigma_2 = \frac{16}{\pi d^3} \left\{ M \pm \sqrt{M^2 + T^2} \right\}$$

$$\text{or } \sigma_1 = \frac{16}{\pi d^3} \left[\left\{ M + \sqrt{M^2 + T^2} \right\} \right]$$

$$\sigma_2 = \frac{16}{\pi d^3} \left[\left\{ M - \sqrt{M^2 + T^2} \right\} \right]$$

$$\text{As } \tau_{\max} = \frac{\sigma_1 - \sigma_2}{2}$$

$$\text{so } \tau_{\max} = \frac{16}{\pi d^3} \left[\left\{ M + \sqrt{M^2 + T^2} \right\} \right] - \frac{16}{\pi d^3} \left[\left\{ M - \sqrt{M^2 + T^2} \right\} \right] \Big/ 2$$

$$\tau_{\max} = \frac{16}{\pi d^3} \sqrt{M^2 + T^2} = \frac{16}{\pi d^3} \cdot T_e$$

where $\sqrt{M^2 + T^2}$ is defined as the equivalent torque, which acting alone would produce the same maximum shear stress as produced by the pure torsion

Thus, $T_e = \sqrt{M^2 + T^2}$

Composite shafts: (in series)

If two or more shaft of different material, diameter or basic forms are connected together in such a way that each carries the same torque, then the shafts are said to be connected in series & the composite shaft so produced is therefore termed as series – connected.

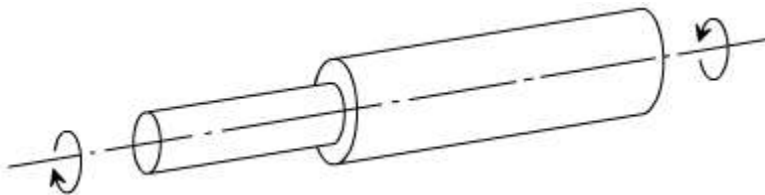

Here in this case the equilibrium of the shaft requires that the torque 'T' be the same through out both the parts.

In such cases the composite shaft strength is treated by considering each component shaft separately, applying the torsion – theory to each in turn. The composite shaft will therefore be as weak as its weakest component. If relative dimensions of the various parts are required then a solution is usually effected by equating the torque in each shaft e.g. for two shafts in series

$$T = \frac{G_1 J_1 \theta_1}{L_1} = \frac{G_2 J_2 \theta_2}{L_2}$$

In some applications it is convenient to ensure that the angle of twist in each shaft are

equal i.e. $q_1 = q_2$, so that for similar materials in each shaft $\frac{J_1}{L_1} = \frac{J_2}{L_2}$ or $\frac{L_1}{L_2} = \frac{J_1}{J_2}$

The total angle of twist at the free end must be the sum of angles $q_1 = q_2$ over each x - section

Composite shaft parallel connection: If two or more shafts are rigidly fixed together such that the applied torque is shared between them then the composite shaft so formed is said to be connected in parallel.

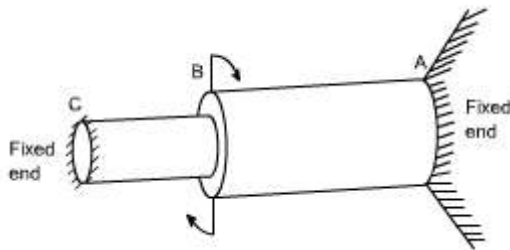

For parallel connection.

Total Torque $T = T_1 + T_2$

In this case the angle of twist for each portion are equal and $\frac{T_1 L_1}{G_1 J_1} = \frac{T_2 L_2}{G_2 J_2}$

for equal lengths(as is normaly the case for parallel shafts) $\frac{T_1}{T_2} = \frac{G_1 J_1}{G_2 J_2}$

This type of configuration is statically indeterminate, because we do not know how the applied torque is apportioned to each segment, To deal such type of problem the procedure is exactly the same as we have discussed earlier,

Thus two equations are obtained in terms of the torques in each part of the composite shaft and the maximum shear stress in each part can then be found from the relations.

$$\tau_1 = \frac{T_1 R_1}{J_1}$$

$$\tau_2 = \frac{T_2 R_2}{J_2}$$

Combined bending, Torsion and Axial thrust:

Sometimes, a shaft may be subjected to a combined bending, torsion and axial thrust. This type of situation arises in turbine propeller shaft

If P = Thrust load

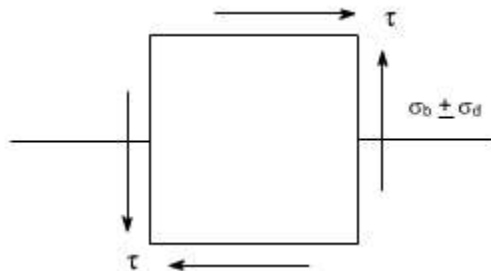
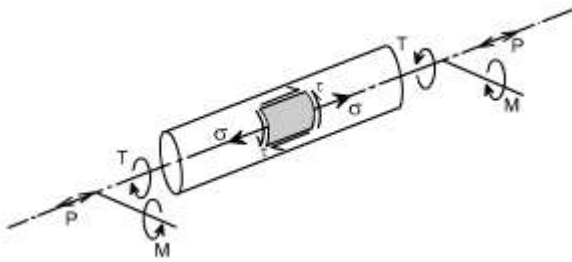

Then $s_d = P / A$ (stress due to thrust)

where s_d is the direct stress depending on the whether the steam is tensile on the whether the stress is tensile or compressive

This type of problem may be analyzed as discussed in earlier case.

Shaft couplings: In shaft couplings, the bolts fail in shear. In this case the torque capacity of the coupling may be determined in the following manner

Assumptions:

The shearing stress in any bolt is assumed to be uniform and is governed by the distance from its center to the centre of coupling.

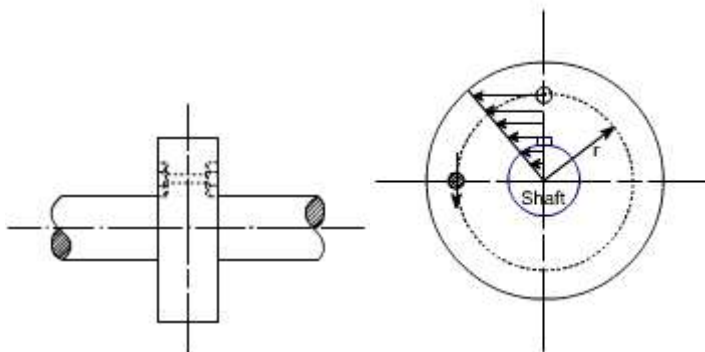

Thus, the torque capacity of the coupling is given as $T = \left(\frac{\pi}{4} d_b^2 \right) \cdot \tau_b \cdot r \cdot n$

where

d_b = diameter of bolt

t'_b = maximum shear stress in bolt

n = no. of bolts

r = distance from center of bolt to center of coupling

LECTURE 35

THEORIES OF ELASTIC FAILURE

While dealing with the design of structures or machine elements or any component of a particular machine the physical properties or chief characteristics of the constituent materials are usually found from the results of laboratory experiments in which the components are subject to the simple stress conditions. The most usual test is a simple tensile test in which the value of stress at yield or fracture is easily determined.

However, a machine part is generally subjected simultaneously to several different types of stresses whose actions are combined therefore, it is necessary to have some basis for determining the allowable working stresses so that failure may not occur. Thus, the function of the theories of elastic failure is to predict from the behavior of materials in a simple tensile test when elastic failure will occur under any conditions of applied stress.

A number of theories have been proposed for the brittle and ductile materials.

Strain Energy: The concept of strain energy is of fundamental importance in applied mechanics. The application of the load produces strain in the bar. The effect of these strains is to increase the energy level of the bar itself. Hence a new quantity called strain energy is defined as the energy absorbed by the bar during the loading process. This strain energy is defined as the work done by load provided no energy is added or subtracted in the form of heat. Some times strain energy is referred to as internal work to distinguish it from external work 'W'. Consider a simple bar which is subjected to tensile force F , having a small element of dimensions dx , dy and dz .

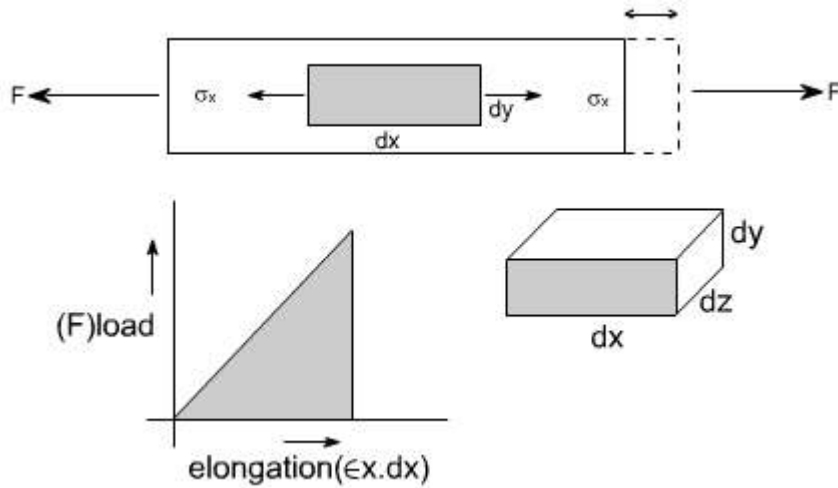

The strain energy U is the area covered under the triangle

$$\begin{aligned}
 U &= \frac{1}{2} F \cdot \epsilon_x \cdot dx \\
 &= \frac{1}{2} \sigma_x \cdot dy dz \cdot dx \epsilon_x \\
 &= \frac{1}{2} \sigma_x \cdot \epsilon_x \cdot dx dy dz \\
 &= \frac{1}{2} \sigma_x \left(\frac{\sigma_x}{E} \right) dx dy dz
 \end{aligned}$$

$$\boxed{\frac{U}{\text{volume}} = \frac{1}{2} \frac{\sigma_x^2}{E}}$$

A three dimension state of stress represented by s_1, s_2 and s_3 may be thought of consisting of two distinct state of stresses i.e Distortional state of stress

Deviatoric state of stress and dilational state of stress

Hydrostatic state of stresses.

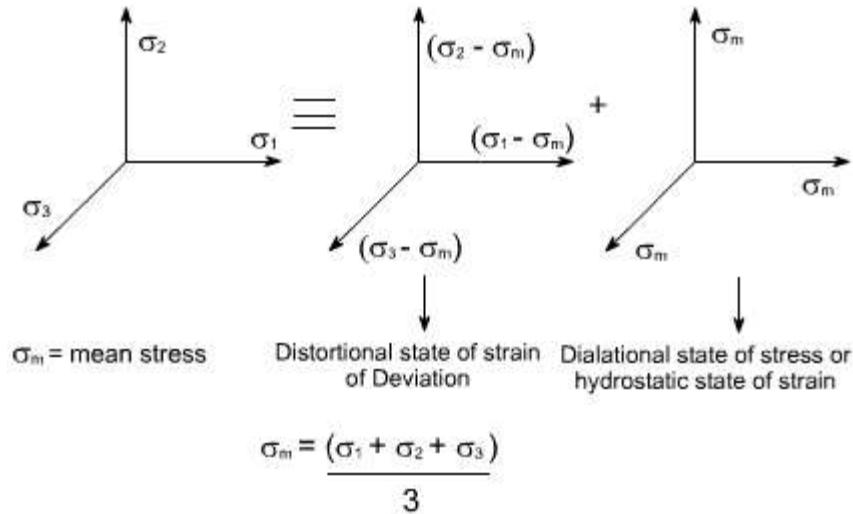

Thus, The energy which is stored within a material when the material is deformed is termed as a strain energy. The total strain energy U_r

$$U_T = U_d + U_H$$

U_d is the strain energy due to the Deviatoric state of stress and U_H is the strain energy due to the Hydrostatic state of stress. Further, it may be noted that the hydrostatic state of stress results in change of volume whereas the deviatoric state of stress results in change of shape.

Different Theories of Failure : These are five different theories of failures which are generally used

- (a) Maximum Principal stress theory (due to Rankine)
- (b) Maximum shear stress theory (Guest - Tresca)
- (c) Maximum Principal strain (Saint - venant) Theory
- (d) Total strain energy per unit volume (Haigh) Theory
- (e) Shear strain energy per unit volume Theory (Von – Mises & Hencky)

In all these theories we shall assume.

σ_{yp} = stress at the yield point in the simple tensile test.

$\sigma_1, \sigma_2, \sigma_3$ - the three principal stresses in the three dimensional complex state of stress systems in order of magnitude.

(a) Maximum Principal stress theory :

This theory assume that when the maximum principal stress in a complex stress system reaches the elastic limit stress in a simple tension, failure will occur.

Therefore the criterion for failure would be

$$s_1 = s_{yp}$$

For a two dimensional complex stress system s_1 is expressed as

$$\sigma_1 = \frac{\sigma_x + \sigma_y}{2} + \frac{1}{2} \sqrt{(\sigma_x - \sigma_y)^2 + 4 \cdot \tau_{xy}^2}$$
$$= \sigma_{yp}$$

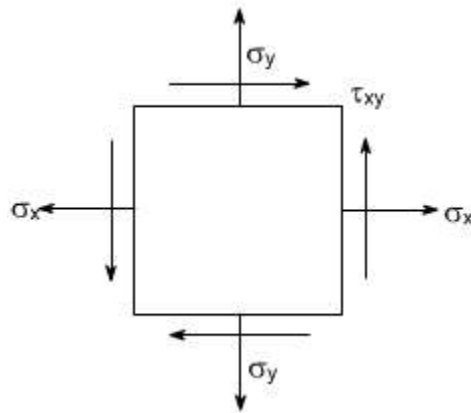

Where s_x , s_y and t_{xy} are the stresses in the any given complex stress system.

(b) Maximum shear stress theory:

This theory states that teh failure can be assumed to occur when the maximum shear stress in the complex stress system is equal to the value of maximum shear stress in simple tension.

The criterion for the failure may be established as given below :

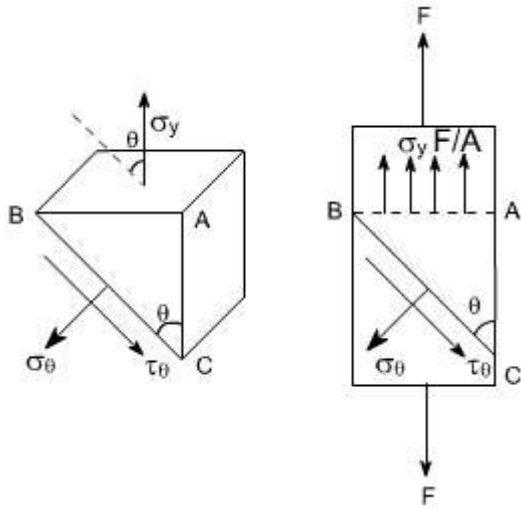

For a simple tension case

$$\sigma_{\theta} = \sigma_y \sin^2 \theta$$

$$\tau_{\theta} = \frac{1}{2} \sigma_y \sin 2\theta$$

$$\tau_{\theta} |_{\max} = \frac{1}{2} \sigma_y \quad \text{or}$$

$$\tau_{\max} = \frac{1}{2} \sigma_{yp}$$

whereas for the two dimensional complex stress system

$$\tau_{\max} = \left(\frac{\sigma_1 - \sigma_2}{2} \right)$$

where σ_1 = maximum principle stress

σ_2 = minimum principle stress

$$\text{so } \frac{\sigma_1 - \sigma_2}{2} = \frac{1}{2} \sqrt{(\sigma_x - \sigma_y)^2 + 4\tau^2}$$

$$\frac{\sigma_1 - \sigma_2}{2} = \frac{1}{2} \sigma_{yp} \Rightarrow \sigma_1 - \sigma_2 = \sigma_y$$

$$\Rightarrow \sqrt{(\sigma_x - \sigma_y)^2 + 4\tau^2} = \sigma_{yp}$$

becomes the criterion for the failure.

(c) Maximum Principal strain theory :

This Theory assumes that failure occurs when the maximum strain for a complex state of stress system becomes equals to the strain at yield point in the tensile test for the three dimensional complex state of stress system.

For a 3 - dimensional state of stress system the total strain energy U_t per unit volume is equal to the total work done by the system and given by the equation

$U_t = 1/2\sigma_1 \epsilon_1 + 1/2\sigma_2 \epsilon_2 + 1/2\sigma_3 \epsilon_3$
 substituting the values of ϵ_1, ϵ_2 and ϵ_3

$$\epsilon_1 = \frac{1}{E} [\sigma_1 - \gamma(\sigma_2 + \sigma_3)]$$

$$\epsilon_2 = \frac{1}{E} [\sigma_2 - \gamma(\sigma_1 + \sigma_3)]$$

$$\epsilon_3 = \frac{1}{E} [\sigma_3 - \gamma(\sigma_1 + \sigma_2)]$$

Thus, the failure criterion becomes

$$\left(\frac{\sigma_1}{E} - \gamma \frac{\sigma_2}{E} - \gamma \frac{\sigma_3}{E} \right) = \frac{\sigma_{yp}}{E}$$

or

$$\boxed{\sigma_1 - \gamma\sigma_2 - \gamma\sigma_3 = \sigma_{yp}}$$

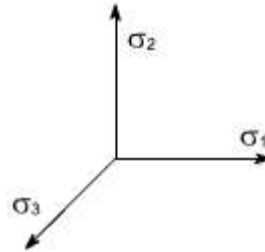

(d) Total strain energy per unit volume theory :

The theory assumes that the failure occurs when the total strain energy for a complex state of stress system is equal to that at the yield point a tensile test.

$$\frac{1}{2E} [\sigma_1^2 + \sigma_2^2 + \sigma_3^2 - 2\gamma(\sigma_1\sigma_2 + \sigma_2\sigma_3 + \sigma_3\sigma_1)] = \frac{\sigma_{yp}^2}{2E}$$

Therefore, the failure criterion becomes $\sigma_1^2 + \sigma_2^2 + \sigma_3^2 - 2\gamma(\sigma_1\sigma_2 + \sigma_2\sigma_3 + \sigma_3\sigma_1) = \sigma_{yp}^2$

It may be noted that this theory gives fair by good results for ductile materials.

(e) Maximum shear strain energy per unit volume theory :

This theory states that the failure occurs when the maximum shear strain energy component for the complex state of stress system is equal to that at the yield point in the tensile test.

$$\frac{1}{12G} [(\sigma_1 - \sigma_2)^2 + (\sigma_2 - \sigma_3)^2 + (\sigma_3 - \sigma_1)^2] = \frac{\sigma_{yp}^2}{6G}$$

Where G = shear modulus of rigidity

Hence the criterion for the failure becomes $[(\sigma_1 - \sigma_2)^2 + (\sigma_2 - \sigma_3)^2 + (\sigma_3 - \sigma_1)^2] = 2\sigma_{yp}^2$

As we know that a general state of stress can be broken into two components i.e,

(i) Hydrostatic state of stress (the strain energy associated with the hydrostatic state of stress is known as the volumetric strain energy)

(ii) Distortional or Deviatoric state of stress (The strain energy due to this is known as the shear strain energy)

As we know that the strain energy due to distortion is given as

$$U_{\text{distortion}} = \frac{1}{12G} \left[(\sigma_1 - \sigma_2)^2 + (\sigma_2 - \sigma_3)^2 + (\sigma_3 - \sigma_1)^2 \right]$$

This is the distortion strain energy for a complex state of stress, this is to be equaled to the maximum distortion energy in the simple tension test. In order to get we may assume that one of the principal stress say (σ_1) reaches the yield point (σ_{yp}) of the material. Thus, putting in above equation $\sigma_2 = \sigma_3 = 0$ we get distortion energy for the simple test i.e

$$U_d = \frac{2\sigma_1^2}{12G}$$

Further $\sigma_1 = \sigma_{yp}$

Thus, $U_d = \frac{\sigma_{yp}^2}{6G}$ for a simple tension test.

LECTURE 36

Elastic Stability Of Columns

Introduction:

Structural members which carry compressive loads may be divided into two broad categories depending on their relative lengths and cross-sectional dimensions.

Columns:

Short, thick members are generally termed columns and these usually fail by crushing when the yield stress of the material in compression is exceeded.

Struts:

Long, slender columns are generally termed as struts, they fail by buckling some time before the yield stress in compression is reached. The buckling occurs owing to one the following reasons.

- (a). the strut may not be perfectly straight initially.
- (b). the load may not be applied exactly along the axis of the Strut.
- (c). one part of the material may yield in compression more readily than others owing to some lack of uniformity in the material properties through out the strut.

In all the problems considered so far we have assumed that the deformation to be both progressive with increasing load and simple in form i.e. we assumed that a member in simple tension or compression becomes progressively longer or shorter but remains straight. Under some circumstances however, our assumptions of progressive and simple deformation may no longer hold good and the member become unstable. The term strut and column are widely used, often interchangeably in the context of buckling of slender members.]

At values of load below the buckling load a strut will be in stable equilibrium where the displacement caused by any lateral disturbance will be totally recovered when the disturbance is removed. At the buckling load the strut is said to be in a state of neutral equilibrium, and theoretically it should than be possible to gently deflect the strut into a simple sine wave provided that the amplitude of wave is kept small.

Theoretically, it is possible for struts to achieve a condition of unstable equilibrium with loads exceeding the buckling load, any slight lateral disturbance then causing failure by buckling, this condition is never achieved in practice under static load conditions. Buckling occurs immediately at the point where the buckling load is reached, owing to the reasons stated earlier.

The resistance of any member to bending is determined by its flexural rigidity EI and is The quantity I may be written as $I = Ak^2$,

Where I = area of moment of inertia

A = area of the cross-section

k = radius of gyration.

The load per unit area which the member can withstand is therefore related to k . There will be two principal moments of inertia, if the least of these is taken then the ratio

$$\frac{l}{k} \quad \text{i.e.} \quad \frac{\text{length of member}}{\text{least radius of gyration}}$$

Is called the slenderness ratio. It's numerical value indicates whether the member falls into the class of columns or struts.

Euler's Theory : The struts which fail by buckling can be analyzed by Euler's theory. In the following sections, different cases of the struts have been analyzed.

Case A: Strut with pinned ends:

Consider an axially loaded strut, shown below, and is subjected to an axial load 'P' this load 'P' produces a deflection 'y' at a distance 'x' from one end.

Assume that the ends are either pin jointed or rounded so that there is no moment at either end.

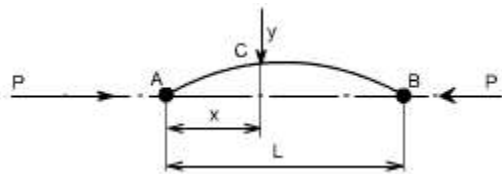

Assumption:

The strut is assumed to be initially straight, the end load being applied axially through centroid.

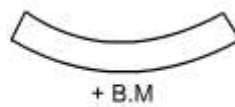
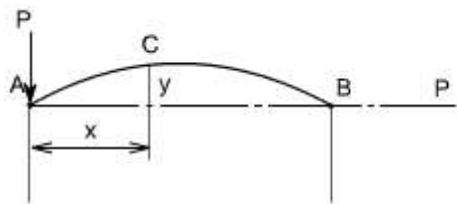

According to sign convention

$$B. M|_C = -Py$$

Further, we know that

$$EI \frac{d^2y}{dx^2} = M$$

$$EI \frac{d^2y}{dx^2} = - P \cdot y = M$$

In this equation 'M' is not a function 'x'. Therefore this equation can not be integrated directly as has been done in the case of deflection of beams by integration method.

Thus,

$$EI \frac{d^2y}{dx^2} + P y = 0$$

Though this equation is in 'y' but we can't say at this stage where the deflection would be maximum or minimum.

So the above differential equation can be arranged in the following form

$$\frac{d^2y}{dx^2} + \frac{Py}{EI} = 0$$

Let us define a operator

$$D = d/dx$$

$$(D^2 + n^2) y = 0 \text{ where } n^2 = P/EI$$

This is a second order differential equation which has a solution of the form consisting of complimentary function and particular integral but for the time being we are interested in the complementary solution only [in this P.I = 0; since the R.H.S of Diff. equation = 0]

$$\text{Thus } y = A \cos (nx) + B \sin (nx)$$

Where A and B are some constants.

$$\text{Therefore } y = A \cos \sqrt{\frac{P}{EI}} x + B \sin \sqrt{\frac{P}{EI}} x$$

In order to evaluate the constants A and B let us apply the boundary conditions,

$$(i) \text{ at } x = 0; y = 0$$

$$(ii) \text{ at } x = L ; y = 0$$

Applying the first boundary condition yields $A = 0$.

Applying the second boundary condition gives

$$B \sin \left(L \sqrt{\frac{P}{EI}} \right) = 0$$

$$\text{Thus either } B = 0, \text{ or } \sin \left(L \sqrt{\frac{P}{EI}} \right) = 0$$

if $B=0$, that $y=0$ for all values of x hence the strut has not buckled yet. Therefore, the solution require

$$\sin \left(L \sqrt{\frac{P}{EI}} \right) = 0 \text{ or } \left(L \sqrt{\frac{P}{EI}} \right) = \pi \text{ or } nL = \pi$$

$$\text{or } \sqrt{\frac{P}{EI}} = \frac{\pi}{L} \text{ or } P = \frac{\pi^2 EI}{L^2}$$

From the above relationship the least value of P which will cause the strut to buckle, and it is called the “ **Euler Crippling Load** ” P_e from which we obtain.

$$P_e = \frac{\pi^2 EI}{L^2}$$

It may be noted that the value of I used in this expression is the least moment of inertia
 It should be noted that the other solutions exists for the equation

$$\sin\left(L\sqrt{\frac{P}{EI}}\right) = 0 \quad \text{i.e. } \sin nL = 0$$

The interpretation of the above analysis is that for all the values of the load P , other than those which make $\sin nL = 0$; the strut will remain perfectly straight since

$$y = B \sin nL = 0$$

For the particular value of

$$P_e = \frac{\pi^2 EI}{L^2}$$

$$\sin nL = 0 \quad \text{or } nL = \pi$$

$$\text{Therefore } n = \frac{\pi}{L}$$

$$\text{Hence } y = B \sin nx = B \sin \frac{\pi x}{L}$$

Then we say that the strut is in a state of neutral equilibrium, and theoretically any deflection which it suffers will be maintained. This is subjected to the limitation that 'L' remains sensibly constant and in practice slight increase in load at the critical value will cause the deflection to increase appreciably until the material fails by yielding.

Further it should be noted that the deflection is not proportional to load, and this applies to all strut problems; like wise it will be found that the maximum stress is not proportional to load.

The solution chosen of $nL = \pi$ is just one particular solution; the solutions $nL = 2\pi, 3\pi, 5\pi$ etc are equally valid mathematically and they do, in fact, produce values of ' P_e ' which are equally valid for modes of buckling of strut different from that of a simple bow. Theoretically therefore, there are an infinite number of values of P_e , each corresponding with a different mode of buckling.

The value selected above is so called the fundamental mode value and is the lowest critical load producing the single bow buckling condition.

The solution $nL = 2\pi$ produces buckling in two half – waves, 3π in three half-waves etc.

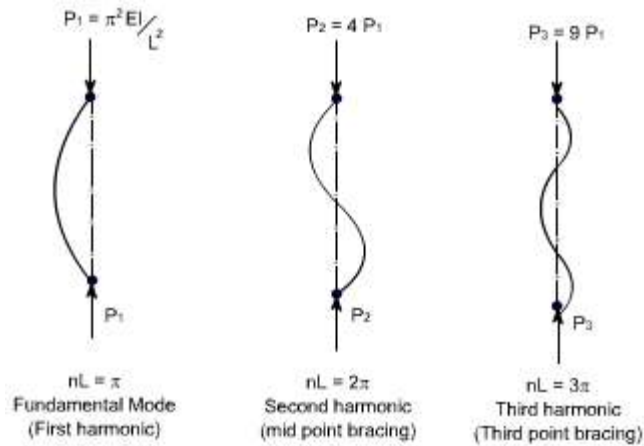

$$L\sqrt{\frac{P}{EI}} = \pi \text{ or } P_1 = \frac{\pi^2 EI}{L^2}$$

$$\text{If } L\sqrt{\frac{P}{EI}} = 2\pi \text{ or } P_2 = \frac{4\pi^2 EI}{L^2} = 4P_1$$

$$\text{If } L\sqrt{\frac{P}{EI}} = 3\pi \text{ or } P_3 = \frac{9\pi^2 EI}{L^2} = 9P_1$$

If load is applied sufficiently quickly to the strut, then it is possible to pass through the fundamental mode and to achieve at least one of the other modes which are theoretically possible. In practical loading situations, however, this is rarely achieved since the high stress associated with the first critical condition generally ensures immediate collapse.

struts and columns with other end conditions: Let us consider the struts and columns having different end conditions

Case b: One end fixed and the other free:

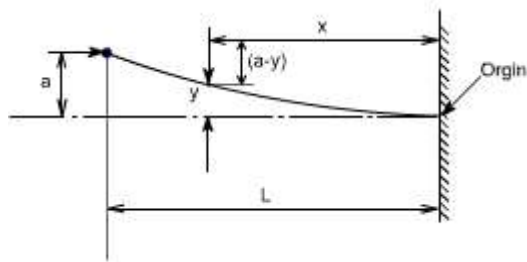

writing down the value of bending moment at the point C

$$B. M|_c = P(a - y)$$

Hence, the differential equation becomes,

$$EI \frac{d^2y}{dx^2} = P(a - y)$$

On rearranging we get

$$\frac{d^2y}{dx^2} + \frac{Py}{EI} = \frac{Pa}{EI}$$

$$\text{Let } \frac{P}{EI} = n^2$$

Hence in operator form, the differential equation reduces to $(D^2 + n^2)y = n^2a$

The solution of the above equation would consist of complementary solution and particular solution, therefore

$$y_{\text{gen}} = A \cos(nx) + \sin(nx) + P. I$$

where

P.I = the P.I is a particular value of y which satisfies the differential equation

$$\text{Hence } y_{P.I} = a$$

Therefore the complete solution becomes

$$Y = A \cos(nx) + B \sin(nx) + a$$

Now imposing the boundary conditions to evaluate the constants A and B

$$(i) \text{ at } x = 0; y = 0$$

$$\text{This yields } A = -a$$

$$(ii) \text{ at } x = 0; dy/dx = 0$$

$$\text{This yields } B = 0$$

Hence

$$y = -a \cos(nx) + a$$

$$\text{Further, at } x = L; y = a$$

$$\text{Therefore } a = -a \cos(nL) + a \quad \text{or } 0 = \cos(nL)$$

Now the fundamental mode of buckling in this case would be

$$nL = \frac{\pi}{2}$$
$$\sqrt{\frac{P}{EI}} L = \frac{\pi}{2}, \text{ Therefore, the Euler's crippling load is given as}$$
$$P_e = \frac{\pi^2 EI}{4L^2}$$

Case 3

Strut with fixed ends:

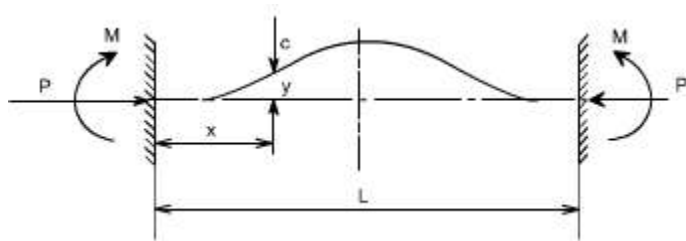

Due to the fixed end supports bending moment would also appear at the supports, since this is the property of the support.

$$\text{Bending Moment at point C} = M - P \cdot y$$

$$EI \frac{d^2 y}{dx^2} = M - Py$$

$$\text{or } \frac{d^2 y}{dx^2} + \frac{P}{EI} = \frac{M}{EI}$$

$n^2 = \frac{P}{EI}$, Therefore in the operator form, the equation reduces to

$$\{D^2 + n^2\} y = \frac{M}{EI}$$

$y_{\text{general}} = y_{\text{complementary}} + y_{\text{particular integral}}$

$$y|_{\text{p.i}} = \frac{M}{n^2 EI} = \frac{M}{P}$$

Hence the general solution would be

$$y = B \cos nx + A \sin nx + \frac{M}{P}$$

Boundary conditions relevant to this case are at $x=0; y=0$

$$B = -\frac{M}{P}$$

Also at $x=0; \frac{dy}{dx} = 0$ hence

$$A=0$$

Therefore,

$$y = -\frac{M}{P} \cos nx + \frac{M}{P}$$

$$y = \frac{M}{P} (1 - \cos nx)$$

Further, it may be noted that at $x=L; y=0$

$$\text{Then } 0 = \frac{M}{P} (1 - \cos nL)$$

Thus, either $\frac{M}{P} = 0$ or $(1 - \cos nL) = 0$

obviously, $(1 - \cos nL) = 0$

$$\cos nL = 1$$

Hence the least solution would be

$$nL = 2\pi$$

$\sqrt{\frac{P}{EI}} L = 2\pi$, Thus, the buckling load or crippling load is

$$P_e = \frac{4\pi^2 \cdot EI}{L^2}$$

Thus,

Case 4

One end fixed, the other pinned

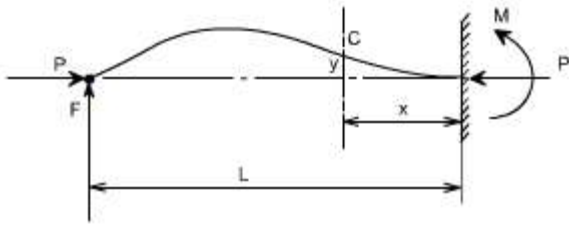

In order to maintain the pin-joint on the horizontal axis of the unloaded strut, it is necessary in this case to introduce a vertical load F at the pin. The moment of F about the built in end then balances the fixing moment.

With the origin at the built in end, the B,M at C is given as

$$EI \frac{d^2 y}{dx^2} = -Py + F(L - x)$$

$$EI \frac{d^2 y}{dx^2} + Py = F(L - x)$$

Hence

$$\frac{d^2 y}{dx^2} + \frac{P}{EI} y = \frac{F}{EI} (L - x)$$

In the operator form the equation reduces to

$$(D^2 + n^2) y = \frac{F}{EI} (L - x)$$

$$y_{\text{particular}} = \frac{F}{n^2 EI} (L - x) \text{ or } y = \frac{F}{P} (L - x)$$

The full solution is therefore

$$y = A \cos nx + B \sin nx + \frac{F}{P} (L - x)$$

The boundary conditions relevant to the problem are at $x=0; y=0$

$$\text{Hence } A = -\frac{FL}{P}$$

$$\text{Also at } x=0; \frac{dy}{dx} = 0$$

$$\text{Hence } B = \frac{F}{nP}$$

$$\text{or } y = -\frac{FL}{P} \cos nx + \frac{F}{nP} \sin nx + \frac{F}{P} (L - x)$$

$$y = \frac{F}{nP} [\sin nx - nL \cos nx + n(L - x)]$$

Also when $x = L ; y = 0$

Therefore

$$nL \cos nL = \sin nL \quad \text{or } \tan nL = nL$$

The lowest value of nL (neglecting zero) which satisfies this condition and which therefore produces the fundamental buckling condition is $nL = 4.49$ radian

$$\begin{aligned} \text{or } \sqrt{\frac{P}{EI}} L &= 4.49 \\ \frac{P_e L^2}{EI} &= 20.2 \\ P_e &= \frac{2.05 \pi^2 EI}{L^2} \end{aligned}$$

Equivalent Strut Length:

Having derived the results for the buckling load of a strut with pinned ends the Euler loads for other end conditions may all be written in the same form.

$$\text{i.e. } P_e = \frac{\pi^2 EI}{L^2}$$

Where L is the equivalent length of the strut and can be related to the actual length of the strut depending on the end conditions.

The equivalent length is found to be the length of a simple bow (half sine wave) in each of the strut deflection curves shown. The buckling load for each end condition shown is then readily obtained. The use of equivalent length is not restricted to the Euler's theory and it will be used in other derivations later.

The critical load for columns with other end conditions can be expressed in terms of the critical load for a hinged column, which is taken as a fundamental case.

For case (c) see the figure, the column or strut has inflection points at quarter points of its unsupported length. Since the bending moment is zero at a point of inflection, the freebody diagram would indicate that the middle half of the fixed ended is equivalent to a hinged column having an effective length $L_e = L / 2$.

The four different cases which we have considered so far are:

- (a) Both ends pinned
- (b) Both ends fixed
- (c) One end fixed, other free
- (d) One end fixed and other pinned

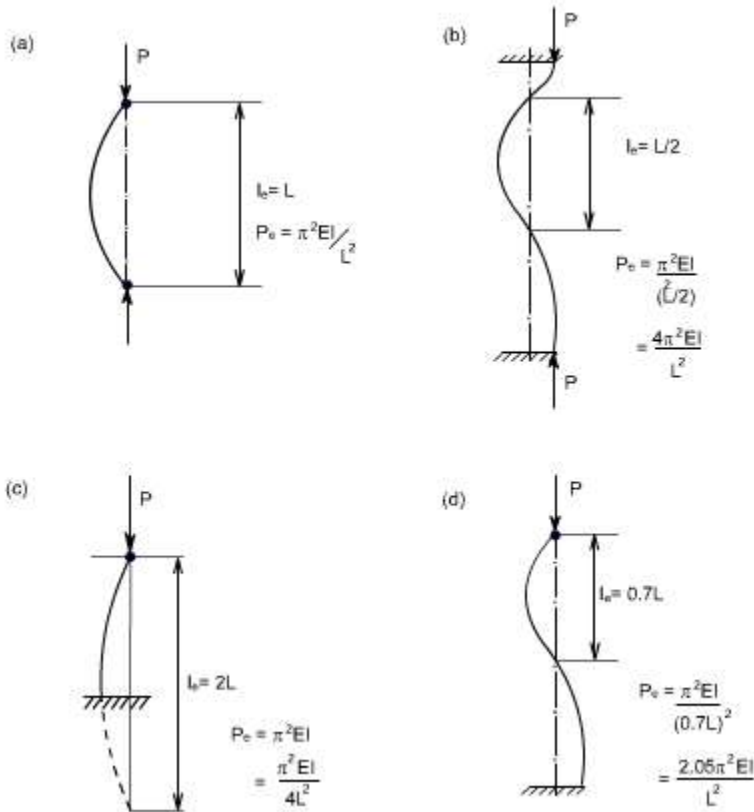

LECTURE 37

Comparison of Euler Theory with Experiment results

Limitations of Euler's Theory :

In practice the ideal conditions are never [i.e. the strut is initially straight and the end load being applied axially through centroid] reached. There is always some eccentricity and initial curvature present. These factors needs to be accommodated in the required formula's.

It is realized that, due to the above mentioned imperfections the strut will suffer a deflection which increases with load and consequently a bending moment is introduced which causes failure before the Euler's load is reached. Infact failure is by stress rather than by buckling and the deviation from the Euler value is more marked as the slenderness-ratio l/k is reduced. For values of $l/k < 120$ approx, the error in applying the Euler theory is too great to allow of its use. The stress to cause buckling from the Euler formula for the pin ended strut is

$$\text{Euler's stress, } \sigma_e = \frac{P_e}{A} = \frac{\pi^2 EI}{Al^2}$$

$$\text{But, } I = Ak^2$$

$$\sigma_e = \frac{\pi^2 E}{\left(\frac{l}{k}\right)^2}$$

A plot of σ_e versus l/k ratio is shown by the curve ABC.

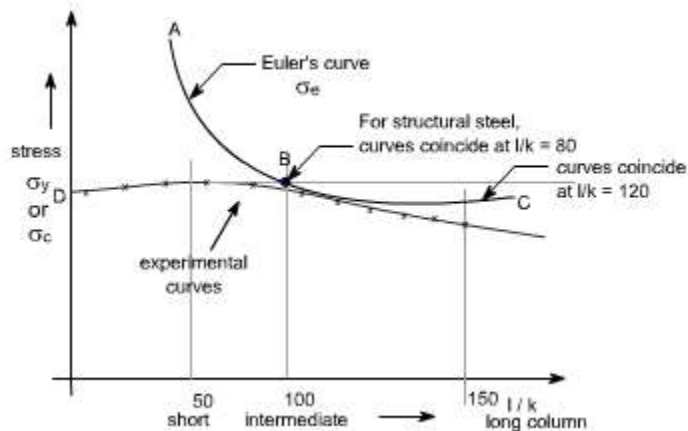

Allowing for the imperfections of loading and strut, actual values at failure must lie within and below line CBD.

Other formulae have therefore been derived to attempt to obtain closer agreement between the actual failing load and the predicted value in this particular range of slenderness ratio i.e. $l/k=40$ to $l/k=100$.

(a) Straight – line formulae :

The permissible load is given by the formulae

$$P = \sigma_y A \left[1 - n \left(\frac{l}{k} \right) \right]$$

Where the value of index 'n' depends on the material used and the end conditions.

(b) Johnson parabolic formulae : The Johnson parabolic formulae is defined as

$$P = \sigma_y A \left[1 - b \left(\frac{l}{k} \right)^2 \right]$$

where the value of index 'b' depends on the end conditions.

(c) Rankine Gordon Formulae :

$$\frac{1}{P_R} = \frac{1}{P_e} + \frac{1}{P_c}$$

Where P_e = Euler crippling load

P_c = Crushing load or Yield point load in Compression

P_R = Actual load to cause failure or Rankine load

Since the Rankine formulae is a combination of the Euler and crushing load for a strut.

$$\frac{1}{P_R} = \frac{1}{P_e} + \frac{1}{P_c}$$

For a very short strut P_e is very large hence $1/P_e$ would be large so that $1/P_e$ can be neglected.

Thus $P_R = P_c$, for very large struts, P_e is very small so $1/P_e$ would be large and $1/P_c$ can be neglected, hence $P_R = P_e$

The Rankine formulae is therefore valid for extreme values of $1/k$. It is also found to be fairly accurate for the intermediate values in the range under consideration. Thus rewriting the formula in terms of stresses, we have

$$\frac{1}{\sigma A} = \frac{1}{\sigma_e A} + \frac{1}{\sigma_y A}$$

$$\frac{1}{\sigma} = \frac{1}{\sigma_e} + \frac{1}{\sigma_y}$$

$$\frac{1}{\sigma} = \frac{\sigma_e + \sigma_y}{\sigma_e \cdot \sigma_y}$$

$$\sigma = \frac{\sigma_e \cdot \sigma_y}{\sigma_e + \sigma_y} = \frac{\sigma_y}{1 + \frac{\sigma_y}{\sigma_e}}$$

For struts with both ends pinned

$$\sigma_e = \frac{\pi^2 E}{\left(\frac{l}{k}\right)^2}$$

$$\sigma = \frac{\sigma_y}{1 + \frac{\sigma_y}{\pi^2 E} \left(\frac{l}{k}\right)^2}$$

$$\sigma = \frac{\sigma_y}{1 + a \left(\frac{l}{k}\right)^2}$$

Where $a = \frac{\sigma_y}{\pi^2 E l}$ and the value of 'a' is found by conducting experiments on various materials. Theoretically, but having a value normally found by experiment for various materials. This will take into account other types of end conditions.

$$\text{Rankine load} = \frac{\sigma_y \cdot A}{1 + a \left(\frac{l}{k}\right)^2}$$

Therefore

Typical values of 'a' for use in Rankine formulae are given below in table.

Material	s _y or s _c MN/m ²	Value of a	
		Pinned ends	Fixed ends
Low carbon steel	315	1/7500	1/30000
Cast Iron	540	1/1600	1/64000
Timber	35	1/3000	1/12000

note a = 4 x (a for fixed ends)

Since the above values of 'a' are not exactly equal to the theoretical values, the

Rankine loads for long struts will not be identical to those estimated by the Euler theory as estimated.

Strut with initial Curvature :

As we know that the true conditions are never realized, but there are always some imperfections. Let us say that the strut is having some initial curvature. i.e., it is not perfectly straight before loading. The situation will influence the stability. Let us analyze this effect.

by a differential calculus

$$R_0 \approx \frac{1}{d^2 y_0 / dx^2} \text{ (Approximately)}$$

$$\text{Further } \frac{E}{R} = \frac{M}{I} \text{ and } \frac{EI}{R} = M$$

$$\text{But for this case } EI \left[\frac{1}{R} - \frac{1}{R_0} \right] = M$$

since strut is having some initial curvature

Now putting

$$\frac{1}{R} = \frac{d^2 y}{dx^2} \text{ and } \frac{1}{R_0} = \frac{d^2 y_0}{dx^2}$$

Where 'y₀' is the value of deflection before the load is applied to the strut when the load is applied to the strut the deflection increases to a value 'y'. Hence

$$EI \left[\frac{d^2 y}{dx^2} - \frac{d^2 y_0}{dx^2} \right] = M$$

$$EI \frac{d^2 y}{dx^2} - EI \frac{d^2 y_0}{dx^2} = M$$

$$EI \frac{d^2 y}{dx^2} = M + EI \frac{d^2 y_0}{dx^2}$$

$$EI \frac{d^2 y}{dx^2} = -Py + EI \frac{d^2 y_0}{dx^2}$$

If the pin-ended strut is under the action of a load P then obviously the BM would be '- py'

Hence

$$EI \frac{d^2 y}{dx^2} + Py = EI \frac{d^2 y_0}{dx^2}$$

$$\frac{d^2 y}{dx^2} + \frac{Py}{EI} = \frac{d^2 y_0}{dx^2}$$

Again letting

$$\frac{P}{EI} = n^2$$

$$\frac{d^2 y}{dx^2} + n^2 y = \frac{d^2 y_0}{dx^2}$$

The initial shape of the strut y_0 may be assumed circular, parabolic or sinusoidal without making much difference to the final results, but the most convenient form is

$$y_0 = C \cdot \sin \frac{\pi x}{l} \text{ where } C \text{ is some constant or here it is amplitude}$$

Which satisfies the end conditions and corresponds to a maximum deviation 'C'. Any other shape could be analyzed into a Fourier series of sine terms. Then

$$\frac{d^2 y}{dx^2} + n^2 y = \frac{d^2 y_0}{dx^2} = \frac{d^2}{dx^2} \left[C \cdot \sin \frac{\pi x}{l} \right] = \left(-C \cdot \frac{\pi^2}{l^2} \right) \sin \left(\frac{\pi x}{l} \right)$$

The computer solution would be therefore be

$$y_{\text{general}} = y_{\text{complementary}} + y_{\text{PI}}$$

$$y = A \cos nx + B \sin nx + \frac{C \cdot \frac{\pi^2}{l^2}}{\left(\frac{\pi^2}{l^2} \right) - n^2} \sin \left(\frac{\pi x}{l} \right)$$

Boundary conditions which are relevant to the problem are

$$\text{at } x = 0 ; y = 0 \text{ thus } B = 0$$

Again

when $x = l$; $y = 0$ or $x = l/2$; $dy/dx = 0$

the above condition gives $B = 0$

Therefore the complete solution would be

$$y = \frac{C \cdot \frac{\pi^2}{l^2}}{\left\{ \left(\frac{\pi^2}{l^2} \right) - n^2 \right\}} \sin\left(\frac{\pi x}{l}\right)$$

Again the above solution can be slightly rearranged. since

$$P_e = \frac{\pi^2 EI}{l^2}$$

hence the term $\frac{\pi^2}{l^2}$ after multiplying the denominator & numerator by EI is equal to

$$\frac{\frac{\pi^2 EI}{l^2}}{\frac{\pi^2 EI}{l^2} - n^2 EI} = \left[\frac{P_e}{P_e - P} \right]$$

Since $n^2 = \frac{P}{EI}$

where $P_e =$ Euler's load $P =$ applied load

Thus

$$y = \frac{C \cdot \frac{\pi^2}{l^2}}{\left\{ \left(\frac{\pi^2}{l^2} \right) - n^2 \right\}} \sin\left(\frac{\pi x}{l}\right)$$

$$y = \left\{ \frac{C P_e}{P_e - P} \right\} \sin\left(\frac{\pi x}{l}\right)$$

The crippling load is again

$$P = P_e = \frac{\pi^2 EI}{l^2}$$

Since the BM for a pin ended strut at any point is given as

$M = -Py$ and

Max BM = $P y_{\max}$

Now in order to define the absolute value in terms of maximum amplitude let us use the symbol as $\hat{\cdot}$.

$$\begin{aligned}\hat{M} &= P \cdot \hat{y} \\ &= C \cdot \frac{P P_e}{(P_e - p)}\end{aligned}$$

Therefore $\hat{M} = \frac{C P P_e}{[P_e - p]}$ since $y_{\max} = \frac{P_e}{[P_e - p]}$

$$\sin \frac{\pi x}{l} = 1 \text{ when } \frac{\pi x}{l} = \frac{\pi}{2}$$

$$\text{Hence } \hat{M} = \frac{C P P_e}{[P_e - p]}$$

Strut with eccentric load

Let 'e' be the eccentricity of the applied end load, and measuring y from the line of action of the load.

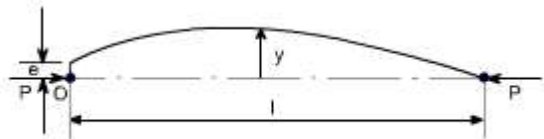

Then $E I \frac{d^2 y}{dx^2} = - P y$

or $(D^2 + n^2) y = 0$ where $n^2 = P / EI$

Therefore $y_{\text{general}} = y_{\text{complementary}}$

$$= A \sin nx + B \cos nx$$

applying the boundary conditions then we can determine the constants i.e.

at $x = 0$; $y = e$ thus $B = e$

at $x = l / 2$; $dy / dx = 0$

Therefore

$$A \cos \frac{nl}{2} - B \sin \frac{nl}{2} = 0$$

$$A \cos \frac{nl}{2} = B \sin \frac{nl}{2}$$

$$A = B \tan \frac{nl}{2}$$

$$A = e \tan \frac{nl}{2}$$

Hence the complete solution becomes

$$y = A \sin(nx) + B \cos(nx)$$

substituting the values of A and B we get

$$y = e \left[\tan \frac{nl}{2} \sin nx + \cos nx \right]$$

Note that with an eccentric load, the strut deflects for all values of P, and not only for the critical value as was the case with an axially applied load. The deflection becomes infinite for $\tan (nl)/2 = \infty$ i.e. $nl = p$ giving the same crippling load $P_e = \frac{\pi^2 EI}{l^2}$. However, due to additional bending moment set up by deflection, the strut will always fail by compressive stress before Euler load is reached.

Since

$$y = e \left[\tan \frac{nl}{2} \sin nx + \cos nx \right]$$

$$y_{\max}^n \Big|_{\text{at } x = \frac{l}{2}} = e \left[\tan \left(\frac{nl}{2} \right) \sin \frac{nl}{2} + \cos \frac{nl}{2} \right]$$

$$= e \left[\frac{\sin^2 \frac{nl}{2} + \cos^2 \frac{nl}{2}}{\cos \frac{nl}{2}} \right]$$

$$= e \left[\frac{1}{\cos \frac{nl}{2}} \right] = e \sec \frac{nl}{2}$$

Hence maximum bending moment would be

$$M_{\max}^n = P y_{\max}^n$$

$$= P e \sec \frac{nl}{2}$$

Now the maximum stress is obtained by combined and direct strain

$$\sigma = \frac{P}{A} + \frac{M}{Z} \text{ stress due to bending } \frac{\sigma}{y} = \frac{M}{I};$$

$$M = \sigma \frac{I}{y}; \sigma_{\max} = \frac{M}{Z} \text{ Wher } Z = I/y \text{ is section modulus}$$

The second term is obviously due the bending action.

Consider a short strut subjected to an eccentrically applied compressive force P at its upper end. If such a strut is comparatively short and stiff, the deflection due to bending action of the eccentric load will be negligible compared with eccentricity 'e' and the principal of super-imposition applies.

If the strut is assumed to have a plane of symmetry (the xy - plane) and the load P lies in this plane at the distance 'e' from the centroidal axis ox .

Then such a loading may be replaced by its statically equivalent of a centrally applied compressive force 'P' and a couple of moment $P.e$

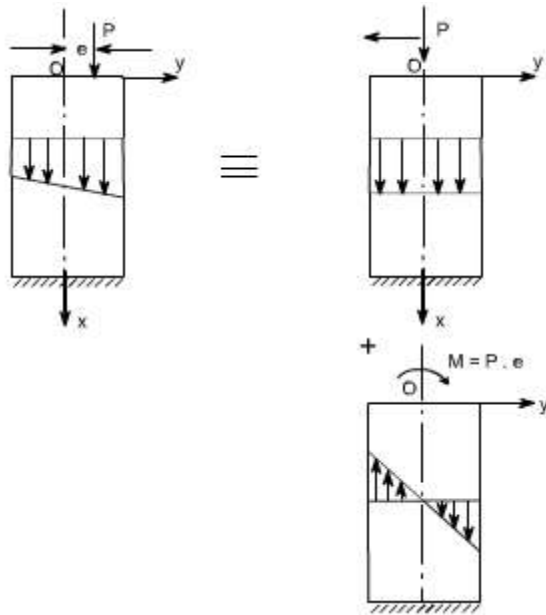

1. The centrally applied load P produces a uniform compressive $\sigma_1 = \frac{P}{A}$ stress over each cross-section as shown by the stress diagram.

2. The end moment 'M' produces a linearly varying bending stress $\sigma_2 = \frac{My}{I}$ as shown in the figure.

Then by super-imposition, the total compressive stress in any fibre due to combined bending and compression becomes,

$$\sigma = \frac{P}{A} + \frac{My}{I}$$

$$\sigma = \frac{P}{A} + \frac{M}{I} \cdot y$$

$$\boxed{\sigma = \frac{P}{A} + \frac{M}{Z}}$$

LECTURE 38

Energy Methods

Strain Energy

Strain Energy of the member is defined as the internal work done in deforming the body by the action of externally applied forces. This energy in elastic bodies is known as **elastic strain energy** :

Strain Energy in uniaxial Loading

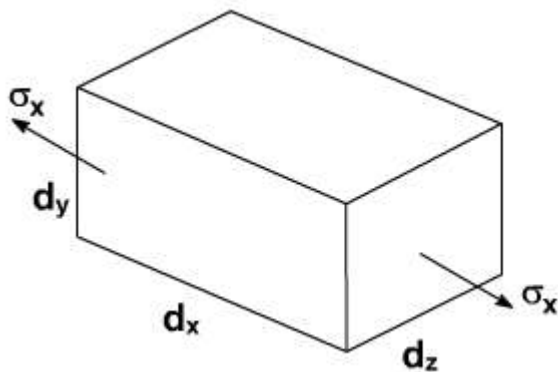

Fig .1

Let us consider an infinitesimal element of dimensions as shown in Fig .1. Let the element be subjected to normal stress s_x .

The forces acting on the face of this element is $s_x \cdot dy \cdot dz$

where

$dydz$ = Area of the element due to the application of forces, the element deforms to an amount = $\hat{I}_x dx$

\hat{I}_x = strain in the material in x – direction

$$= \frac{\text{Change in length}}{\text{Original in length}}$$

Assuming the element material to be as linearly elastic the stress is directly proportional to strain as shown in Fig . 2.

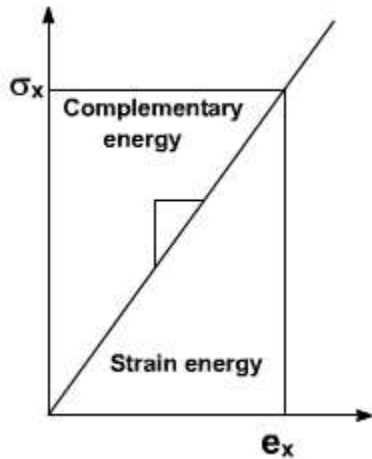

Fig .2

\ From Fig .2 the force that acts on the element increases linearly from zero until it attains its full value.

Hence average force on the element is equal to $\frac{1}{2} s_x \cdot dy \cdot dz$.

\ Therefore the workdone by the above force

Force = average force x deformed length

$$= \frac{1}{2} s_x \cdot dydz \cdot \hat{I}_x \cdot dx$$

For a perfectly elastic body the above work done is the internal strain energy “du”.

$$\boxed{du = \frac{1}{2} \sigma_x dydz \epsilon_x dx} \quad \dots(2)$$

$$= \frac{1}{2} \sigma_x \epsilon_x dx dy dz$$

$$\boxed{du = \frac{1}{2} \sigma_x \epsilon_x dv} \quad \dots\dots(3)$$

where $dv = dx dy dz$

= Volume of the element

By rearranging the above equation we can write

$$U_o = \frac{du}{dv} = \frac{1}{2} \sigma_x \epsilon_x \quad \dots(4)$$

The equation (4) represents the strain energy in elastic body per unit volume of the

material its strain energy – density ‘ u_0 ’ .

From Hook's Law for elastic bodies, it may be recalled that

$$\sigma = E \epsilon$$

$$U_0 = \frac{du}{dv} = \frac{\sigma_x^2}{2E} = \frac{E \epsilon_x^2}{2} \quad \dots\dots(5)$$

$$U = \int_{Vol} \frac{\sigma_x^2}{2E} dv \quad \dots\dots(6)$$

In the case of a rod of uniform cross – section subjected at its ends an equal and opposite forces of magnitude P as shown in the Fig .3.

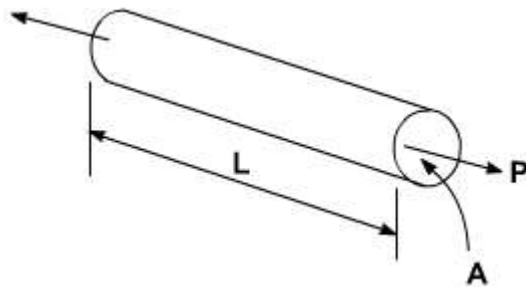

Fig .3

$$U = \int_{Vol} \frac{\sigma_x^2}{2E} dv$$

$$\sigma_x = \frac{P}{A}$$

$$U = \int_0^L \frac{P^2}{2EA^2} A dx$$

$dv = A dx =$ Element volume

A = Area of the bar.

L = Length of the bar

$$U = \frac{P^2 L}{2AE}$$

.....(7)

Modulus of resilience :

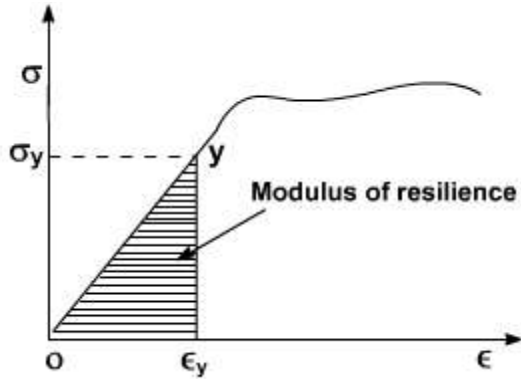

Fig .4

Suppose ‘ s_x ’ in strain energy equation is put equal to s_y i.e. the stress at proportional limit or yield point. The resulting strain energy gives an index of the materials ability to store or absorb energy without permanent deformation

So
$$U_y = \frac{\sigma_y^2}{2E} \quad \dots(B)$$

The quantity resulting from the above equation is called the Modulus of resilience

The modulus of resilience is equal to the area under the straight line portion ‘OY’ of the stress – strain diagram as shown in Fig .4 and represents the energy per unit volume that the material can absorb without yielding. Hence this is used to differentiate materials for applications where energy must be absorbed by members.

Modulus of Toughness :

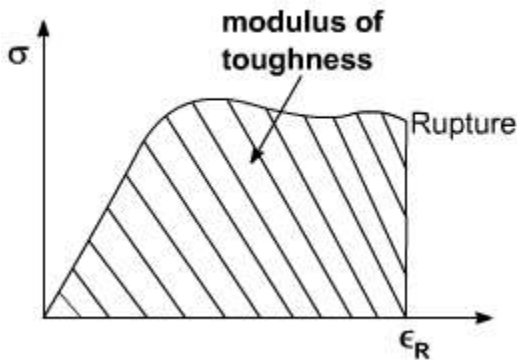

Fig .5

Suppose ‘ $\hat{\epsilon}$ ’ [strain] in strain energy expression is replaced by $\hat{\epsilon}_R$ strain at rupture, the resulting strain energy density is called modulus of toughness

$$U = \int_0^{\epsilon} E \epsilon_x dx = \frac{E \epsilon_R^2}{2} dv$$

$$U = \frac{E \epsilon_R^2}{2} \dots\dots(9)$$

From the stress – strain diagram, the area under the complete curve gives the measure of modulus of toughness. It is the materials.

Ability to absorb energy upto fracture. It is clear that the toughness of a material is related to its ductility as well as to its ultimate strength and that the capacity of a structure to withstand an impact Load depends upon the toughness of the material used.

ILLUSTRATIVE PROBLEMS

- Three round bars having the same length 'L' but different shapes are shown in fig below. The first bar has a diameter 'd' over its entire length, the second had this diameter over one – fourth of its length, and the third has this diameter over one eighth of its length. All three bars are subjected to the same load P. Compare the amounts of strain energy stored in the bars, assuming the linear elastic behavior.

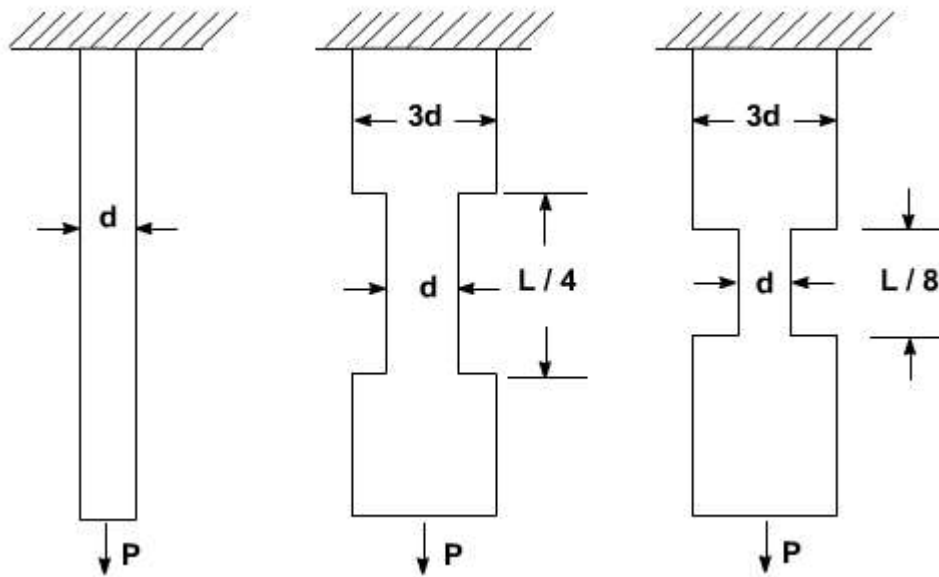

Solution :

1. The strain Energy of the first bar is expressed as

$$U_1 = \frac{P^2 L}{2EA}$$

2. The strain Energy of the second bar is expressed as

$$U_2 = \frac{P^2 (L/4)}{2EA} + \frac{P^2 (3L/4)}{2E(9A)} = \frac{P^2 L}{6EA}$$

$$U_2 = \frac{U_1}{3}$$

3. The strain Energy of the third bar is expressed as

$$U_3 = \frac{P^2 (L/8)}{2EA} + \frac{P^2 (7L/8)}{2E(9A)}$$

$$U_3 = \frac{P^2 L}{9EA}$$

$$U_3 = \frac{2U_1}{9}$$

From the above results it may be observed that the strain energy decreases as the volume of the bar increases.

2. Suppose a rod AB must acquire an elastic strain energy of 13.6 N.m using $E = 200$ GPa. Determine the required yield strength of steel. If the factor of safety w.r.t. permanent deformation is equal to 5.

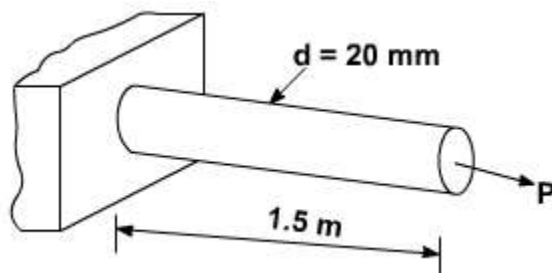

Solution :

Factor of safety = 5

Therefore, the strain energy of the rod should be $u = 5 [13.6] = 68$ N.m

Strain Energy density

The volume of the rod is

$$\begin{aligned}
 V &= AL = \frac{\pi}{4} d^2 L \\
 &= \frac{\pi}{4} 20 \times 1.5 \times 10^3 \\
 &= 471 \times 10^3 \text{ mm}^3
 \end{aligned}$$

Yield Strength :

As we know that the modulus of resilience is equal to the strain energy density when maximum stress is equal to s_x .

$$U = \frac{\sigma_y^2}{2E}$$

$$0.144 = \frac{\sigma_y^2}{2 \times (200 \times 10^3)}$$

$$\boxed{\sigma_y = 200 \text{ Mpa}}$$

It is important to note that, since energy loads are not linearly related to the stress they produce, factor of safety associated with energy loads should be applied to the energy loads and not to the stresses.

Strain Energy in Bending :

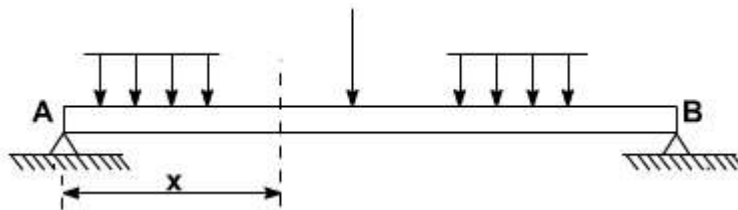

Fig .6

Consider a beam AB subjected to a given loading as shown in figure.

Let

M = The value of bending Moment at a distance x from end A.

From the simple bending theory, the normal stress due to bending alone is expressed as.

$$\sigma = \frac{M Y}{I}$$

Substituting the above relation in the expression of strain energy

$$\begin{aligned} \text{i.e. } U &= \int \frac{\sigma^2}{2E} dv \\ &= \int \frac{M^2 \cdot y^2}{2EI^2} dv \quad \dots(10) \end{aligned}$$

Substituting $dv = dx dA$

Where dA = elemental cross-sectional area

$\frac{M^2 \cdot y^2}{2EI^2} \rightarrow$ is a function of x alone

Now substituting for dv in the expression of U .

$$U = \int_0^L \frac{M^2}{2EI^2} \left(\int y^2 dA \right) dx \quad \dots(11)$$

We know $\int y^2 dA$ represents the moment of inertia 'I' of the cross-section about its neutral axis.

$$U = \int_0^L \frac{M^2}{2EI} dx \quad \dots(12)$$

ILLUSTRATIVE PROBLEMS

1. Determine the strain energy of a prismatic cantilever beam as shown in the figure by taking into account only the effect of the normal stresses.

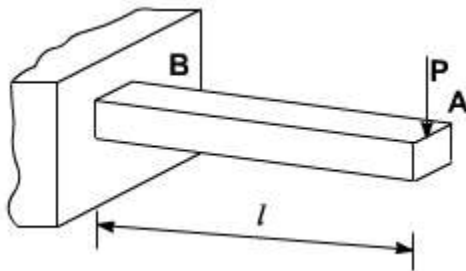

Solution : The bending moment at a distance x from end A is defined as

$$M = -Px$$

Substituting the above value of M in the expression of strain energy we may write

$$U = \int_0^L \frac{P^2 x^2}{2EI} dx$$

$$U = \int_0^L \frac{P^2 L^3}{EI}$$

Problem 2 :

- Determine the expression for strain energy of the prismatic beam AB for the loading as shown in figure below. Take into account only the effect of normal stresses due to bending.
- Evaluate the strain energy for the following values of the beam

$$P = 208 \text{ KN} ; L = 3.6 \text{ m} = 3600 \text{ mm}$$

$$A = 0.9 \text{ m} = 90 \text{ mm} ; b = 2.7 \text{ m} = 2700 \text{ mm}$$

$$E = 200 \text{ GPa} ; I = 104 \times 10^8 \text{ mm}^4$$

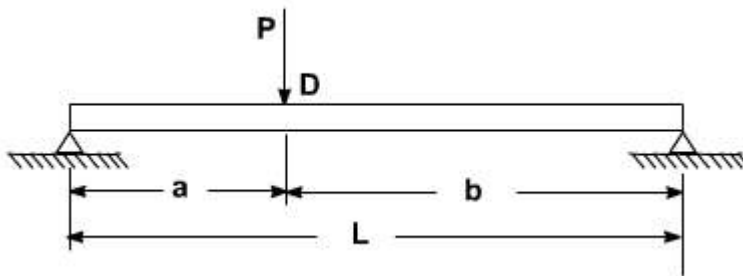

Solution:

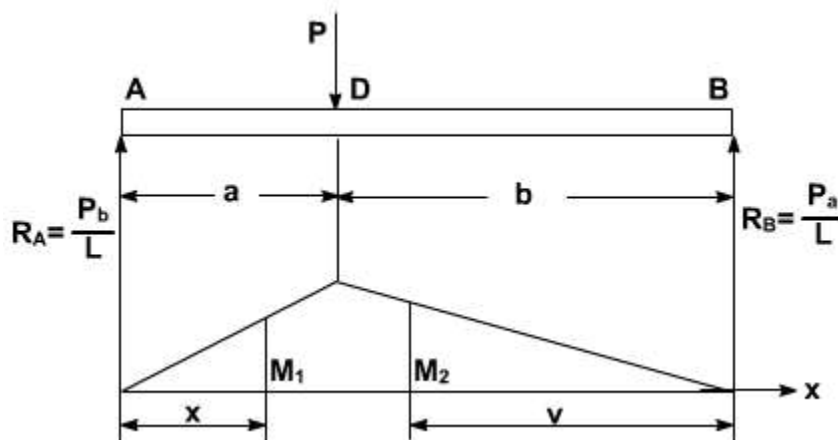

a.

Bending Moment : Using the free – body diagram of the entire beam, we may determine the values of reactions as follows:

$$R_A = P_b / L \quad R_B = P_a / L$$

For Portion AD of the beam, the bending moment is

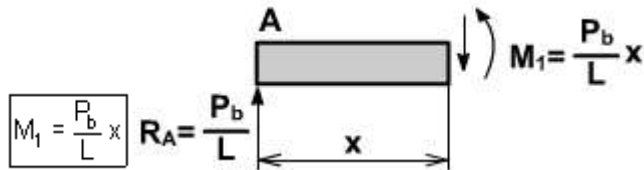

For Portion DB, the bending moment at a distance v from end B is

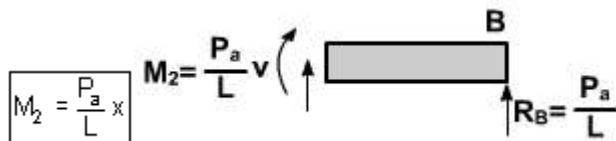

Strain Energy :

Since strain energy is a scalar quantity, we may add the strain energy of portion AD to that of DB to obtain the total strain energy of the beam.

$$\begin{aligned} U &= U_{AD} + U_{DB} \\ &= \int_0^a \frac{M_1^2}{2EI} dx + \int_0^b \frac{M_2^2}{2EI} dv \\ &= \frac{1}{2EI} \int_0^a \left(\frac{P_b}{L} x \right)^2 dx + \frac{1}{2EI} \int_0^b \left(\frac{P_a}{L} v \right)^2 dx \\ &= \frac{1}{2EI} \frac{P^2}{L^2} \left(\frac{b^2 a^3}{3} + \frac{a^2 b^3}{3} \right) \end{aligned}$$

$$U = \frac{P^2 a^2 b^2}{6EIL^2} (a + b)$$

Since $(a + b) = L$

$$U = \frac{P^2 a^2 b^2}{6EIL}$$

b. Substituting the values of P, a, b, E, I, and L in the expression above.

$$U = \frac{(200 \times 10^3)^2 \times (900)^2 \times (2700)^2}{6 (200 \times 10^3) \times (104 \times 10^6) \times (3600)} = 5.27 \times 10^7 \text{ KN.m}$$

Problem

3) Determine the modulus of resilience for each of the following materials.

a. Stainless steel . $E = 190 \text{ GPa}$ $s_y = 260 \text{ MPa}$

b. Malleable constantan $E = 165 \text{ GPa}$ $s_y = 230 \text{ MPa}$

c. Titanium $E = 115 \text{ GPa}$ $s_y = 830 \text{ MPa}$

d. Magnesium $E = 45 \text{ GPa}$ $s_y = 200 \text{ MPa}$

4) For the given Loading arrangement on the rod ABC determine

(a). The strain energy of the steel rod ABC when

$P = 40 \text{ KN}$.

(b). The corresponding strain energy density in portions AB and BC of the rod.

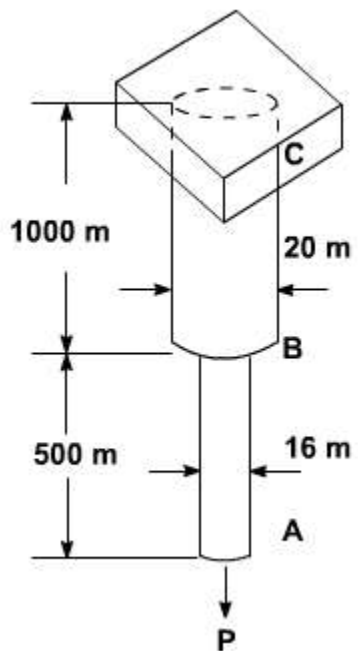

LECTURE 39

Complementary Strain Energy :

Consider the stress strain diagram as shown Fig 39.1. The area enclosed by the inclined line and the vertical axis is called the complementary strain energy. For a linearly elastic materials the complementary strain energy and elastic strain energy are the same.

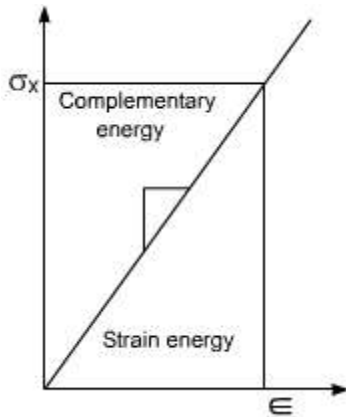

Fig 39.1

Let us consider elastic non linear prismatic bar subjected to an axial load. The resulting stress strain plot is as shown.

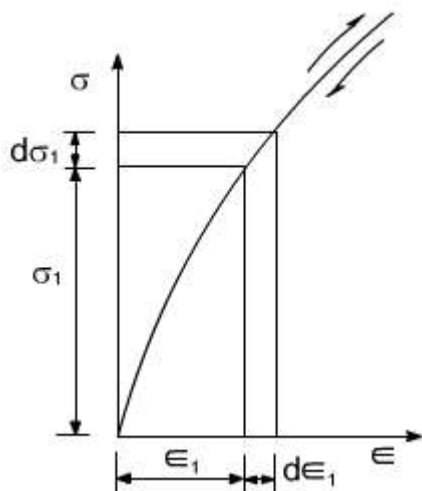

Fig 39. 2

The new term complementary work is defined as follows

$$W^* = \int_0^P \delta_1 dP_1$$

we also know

$$W^* + W = P\delta$$

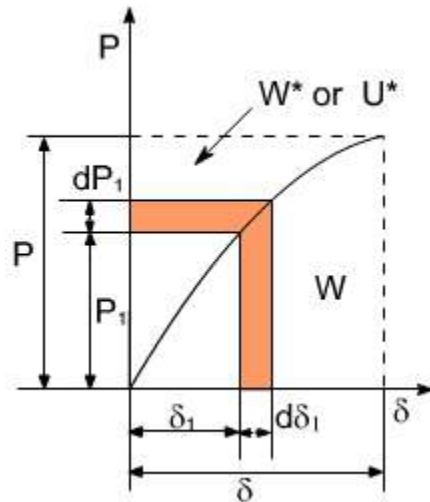

So In geometric sense the work W^* is the complement of the work 'W' because it completes rectangle as shown in the above figure

Complementary Energy

$$U^* = W^* = \int_0^P \delta_1 dP$$

Likewise the complementary energy density u^* is obtained by considering a volume element subjected to the stress s_1 and \hat{l}_1 , in a manner analogous to that used in defining the strain energy density. Thus

$$U^* = \int_0^{\sigma} \epsilon_1 d\sigma_1$$

The complementary energy density is equal to the area between the stress strain curve and the stress axis. The total complementary energy of the bar may be obtained from u^* by integration

$$U^* = \int dv$$

Sometimes the complementary energy is also called the stress energy. Complementary Energy is expressed in terms of the load and that the strain energy is expressed in terms

of the displacement.

Castigliano's Theorem : Strain energy techniques are frequently used to analyze the deflection of beam and structures. Castigliano's theorem were developed by the Italian engineer Alberto castigliano in the year 1873, these theorems are applicable to any structure for which the force deformation relations are linear

Castigliano's Therom :

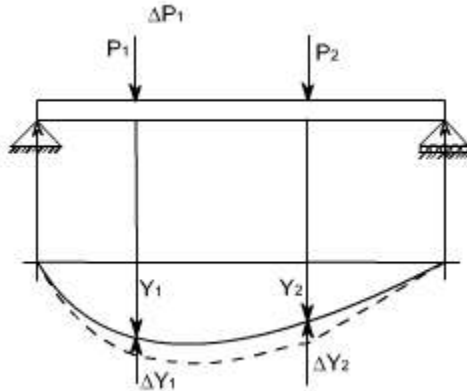

Consider a loaded beam as shown in figure

Let the two Loads P_1 and P_2 produce deflections Y_1 and Y_2 respectively strain energy in the beam is equal to the work done by the forces.

$$U = \frac{1}{2}P_1Y_1 + \frac{1}{2}P_2Y_2 \quad \dots(1)$$

Let the Load P_1 be increased by an amount DP_1 .

Let DP_1 and DP_2 be the corresponding changes in deflection due to change in load to DP_1 .

Now the increase in strain energy $\Delta U = \frac{1}{2}\Delta P_1\Delta Y_1 + P_1\Delta Y_1 + P_2\Delta Y_2 \quad \dots(2)$

Suppose the increment in load is applied first followed by P_1 and P_2 then the resulting strain energy is

$$U+\Delta U = \frac{1}{2}\Delta P_1\Delta Y_1 + \Delta P_1Y_1 + P_2\Delta Y_2 + \frac{1}{2}P_1Y_1 + \frac{1}{2}P_2Y_2 \quad \dots(3)$$

Since the resultant strain energy is independent of order loading,

Combining equation 1, 2 and 3. One can obtain

$$\Delta P_1 Y_1 = P_1 \Delta Y_1 + P_2 \Delta Y_2 \quad \dots(4)$$

equations (2) and (4) can be combined to obtain

$$\frac{\Delta U}{\Delta P_1} = y_1 + \frac{1}{2} \Delta Y_1 \quad \dots(5)$$

or upon taking the limit as ΔP_1 approaches zero [Partial derivative are used because the strain energy is a function of both P_1 and P_2]

$$\frac{\partial U}{\partial P} = Y_1 \quad \dots(6)$$

For a general case there may be number of loads, therefore, the equation (6) can be written as

$$\frac{\partial U}{\partial P_i} = Y_i \quad \dots(7)$$

The above equation is castigation's theorem:

The statement of this theorem can be put forth as follows; if the strain energy of a linearly elastic structure is expressed in terms of the system of external loads. The partial derivative of strain energy with respect to a concentrated external load is the deflection of the structure at the point of application and in the direction of that load.

In a similar fashion, castigliano's theorem can also be valid for applied moments and resulting rotations of the structure

$$\frac{\partial U}{\partial M_i} = \theta_i \quad \dots(8)$$

Where

M_i = applied moment

θ_i = resulting rotation

Castigliano's First Theorem :

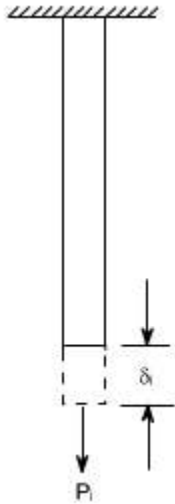

In similar fashion as discussed in previous section suppose the displacement of the structure are changed by a small amount dd_i . While all other displacements are held constant the increase in strain energy can be expressed as

$$\boxed{dU = \frac{\partial U}{\partial \delta_i} d\delta_i} \quad \dots (9)$$

Where

$\partial U / \partial \delta_i$ is the rate of change of the strain energy w.r.t δ_i .

It may be seen that, when the displacement δ_i is increased by the small amount dd ; workdone by the corresponding force only since other displacements are not changed.

The work which is equal to $P_i d\delta_i$ is equal to increase in strain energy stored in the structure

$$\boxed{dU = P_i d\delta_i}$$

By rearranging the above expression, the Castigliano's first theorem becomes

$$\boxed{P_i = \frac{dU}{d\delta_i}}$$

The above relation states that the partial derivative of strain energy w.r.t. any displacement δ_i is equal to the corresponding force P_i provided that the strain is expressed as a function of the displacements.

LECTURE 40

ILLUSTRATIVE PROBLEMS

Using Castigliano's Theorem :

1. The cantilever beam CD supports a uniformly distributed Load w . and a concentrated load P as shown in figure below. Suppose

$L = 3\text{m}$; $w = 6\text{KN/m}$; $P = 6\text{KN}$ and $E. I = 5 \text{ MN m}^2$ determine the deflection at D

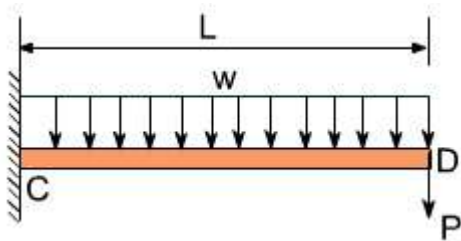

The deflection ' Y_0 ' at the point D Where load ' P ' is applied is obtained from the relation

$$\delta_i = \frac{\partial U}{\partial R_i}$$

Since P is acting vertical and directed downward d ; represents a vertical deflection and is positions downward.

$$\delta_D = \frac{\partial U}{\partial P} = \int_0^L \frac{M}{EI} \frac{\partial M}{\partial P} dx \quad \dots(1)$$

The bending moment M at a distance x from D

$$M = - \left(Px + \frac{1}{2} wx^2 \right) \quad \dots(2)$$

And its derivative with respect to ' P ' is

$$\frac{\partial M}{\partial P} = -x \quad \dots(3)$$

Substituting for M and $\frac{\partial M}{\partial P}$ into equation (1)

$$Y_D = \frac{1}{EI} \int_0^l \left(Px + \frac{1}{2} wx^2 \right)$$

$$Y_D = \frac{1}{EI} \left(\frac{PL^3}{3} + \frac{wL^2}{8} \right)$$

Substituting the values of P,L,w and EI

$$Y_D = \frac{1}{5 \times 10^6} \left(\frac{8 \times 3^3 \times 10^3}{3} + \frac{6 \times 10^3 \times 3^4}{8} \right)$$

$$Y_D = 26.55 \times 10^{-3} \text{ m}$$

$$Y_D = 26.55 \text{ mm}$$

2.

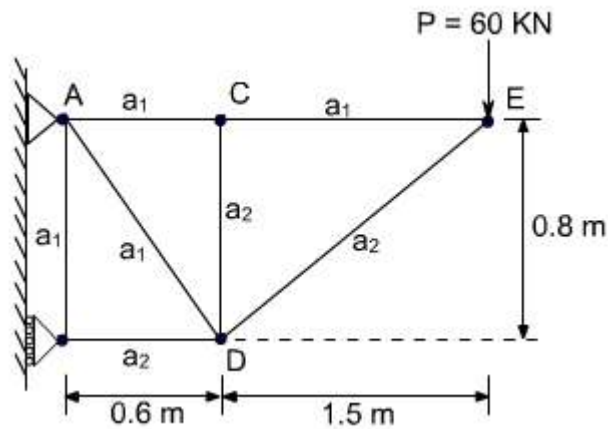

Areas

$$a_1 = 500 \text{ mm}^2$$

$$a_2 = 1000 \text{ mm}^2$$

For the truss as shown in the figure above, Determine the vertical deflection at the joint C.

Solution:

Since no vertical load is applied at Joint C. we may introduce dummy load Q. as shown below

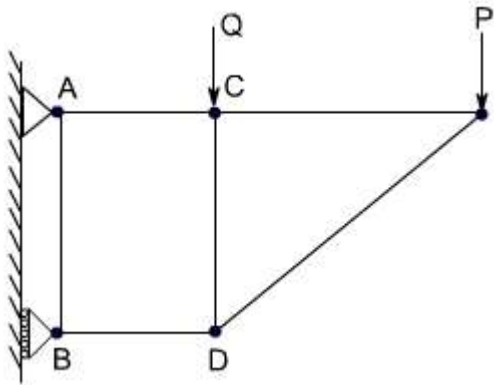

Using castigliano's theorem and denoting by the force F_i in a given member i caused by the combined loading of P and Q . we have

$$\Delta_c = \sum \left(\frac{F_i L_i}{A_i E} \right) \frac{\partial F}{\partial Q} = \frac{1}{E} \sum \left(\frac{F_i L_i}{A_i} \right) \frac{\partial F}{\partial Q} \quad \dots(1)$$

Free body diagram : The free body diagram is as shown below

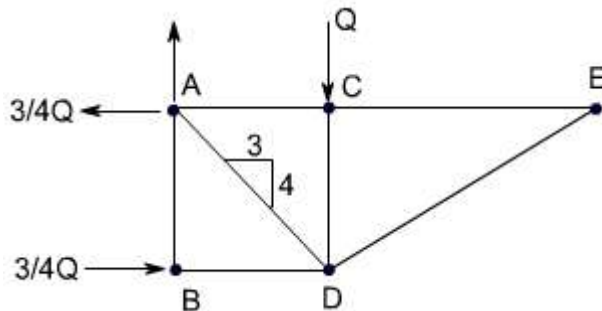

Force in Members:

Considering in sequence, the equilibrium of joints E , C , B and D , we may determine the force in each member caused by load Q .

Joint E : $F_{CE} = F_{DE} = 0$

Joint C : $F_{AC} = 0$; $F_{CD} = -Q$

Joint B : $F_{AB} = 0$; $F_{BD} = -3/4Q$

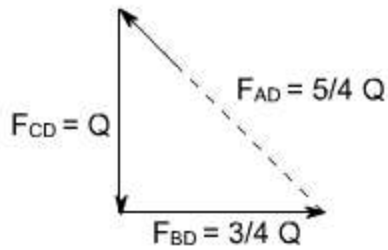

The total force in each member under the combined action of Q and P is

Member	F_i	$\frac{F_i}{Q}$	L_i, m	A_i, m^2	$\left(\frac{F_i L_i}{A_i}\right) \frac{\partial F_i}{\partial A_i}$
B	0	0	0.8	5000×10^{-6}	0
C	$+15P/8$	0	0.6	5000×10^{-6}	0
D	$+5P/4 + 5Q/4$	$5/4$	1.0	5000×10^{-6}	$3125P + 3125Q$
D	$-21P/8 - 3Q/4$	$-3/4$	0.6	1000×10^{-6}	$1181P + 338Q$
D	$-Q$	-1	0.8	1000×10^{-6}	$+800Q$
E	$15P/8$	0	1.5	500×10^{-6}	0
E	$-17P/8$	0	1.7	1000×10^{-6}	0

$P = 60 \text{ KN}$

$$\sum \left(\frac{F_i L_i}{A_i} \right) \frac{\partial F_i}{\partial Q} = 4306P + 4263Q \quad \dots\dots(2)$$

Sub-(2) in (1)

Deflection of C.

$$\begin{aligned} Y_c &= \sum \left(\frac{F_i L_i}{A_i} \right) \frac{\partial F_i}{\partial Q} \\ &= \frac{1}{E} (4306P + 4263Q) \end{aligned}$$

Since the load Q is not the part of loading therefore putting $Q = 0$

$$Y_c = \frac{1}{73 \times 10^9} [4306] \times [60 \times 10^3]$$

$$Y_c = 3.539 \times 10^{-3} \text{ m}$$

$$Y_c = 3.539 \text{ mm}$$

3. For the beam and loading shown, determine the deflection at point D. Take $E = 200 \text{ GPa}$, $I = 28.9 \times 10^6 \text{ mm}^4$

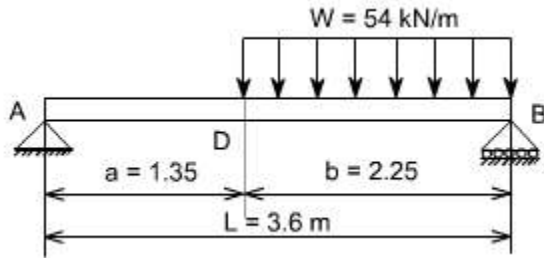

Solution:

Castigliano's Theorem :

Since the given loading does not include a vertical load at point D, we introduce the dummy load Q as shown below. Using Castigliano's Theorem and noting that $E.I$ is constant, we write.

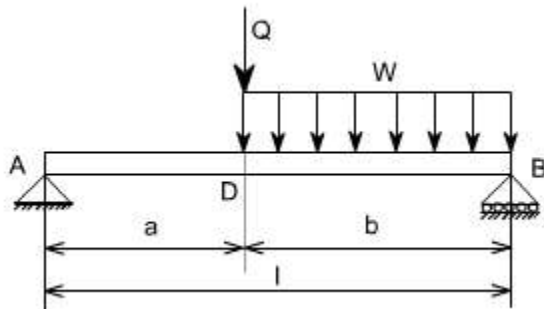

$$Y_D = \int \frac{M}{EI} \left(\frac{\partial M}{\partial Q} \right) dx$$

$$Y_D = \frac{1}{EI} \int M \left(\frac{\partial M}{\partial Q} \right) dx \quad \dots\dots(1)$$

The integration is performed separately for portion AD and DB

Reactions

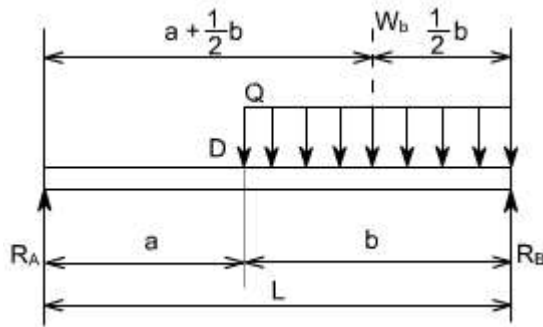

Using F.B.D of the entire beam

$$R_A = \frac{wb^2}{2L} + Q \frac{b}{L} \uparrow$$

$$R_B = \frac{wb(a + 1/2b)^2}{L} + Q \frac{a}{L} \uparrow$$

Portion AD of Beam :

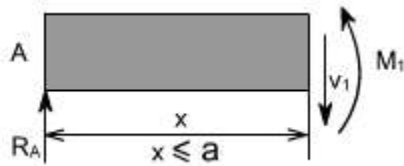

From Using the F.B.D. we find

$$M_1 = R_A x = \left(\frac{wb^2}{2L} + Q \frac{b}{L} \right) x$$

$$\frac{\partial M_1}{\partial Q} = \frac{bx}{L}$$

Substituting into equation (1) and integrating from A to D. gives

$$\begin{aligned} \frac{1}{EI} \int M_1 \left(\frac{\partial M_1}{\partial Q} \right) dx &= \frac{1}{EI} \int_0^a R_A x \left(\frac{bx}{L} \right) dx \\ &= \frac{R_A a^3 b}{3EI} \end{aligned}$$

Substituting for R_A and then set the dummy load 'q' equal to zero

$$\frac{1}{EI} \int M_1 \left(\frac{\partial M_1}{\partial Q} \right) dx = \frac{wa^3 b^3}{6EI L^2} \quad \dots\dots(2)$$

Portion DB of Beam :

From Using the F.B.D shown below we find the bending moment at a distance V from end B is

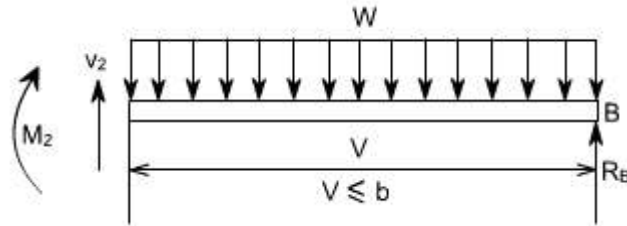

$$M_2 = R_2 V - \frac{wV^2}{2}$$

$$= \left(\frac{wb(a + 1/2b)^2}{L} + Q \frac{a}{L} \right) V - \frac{wV^2}{2}$$

$$\boxed{\frac{\partial M_2}{\partial Q} = + \frac{aV}{L}}$$

Substituting into equation (1) and integrating from point 'b' where V = 0, to point 'D' where V = l

$$\frac{1}{EI} \int M_2 \frac{\partial M_2}{\partial Q} dv = \frac{1}{EI} \int_0^b \left(R_B V - \frac{wV^2}{2} \right) \left(\frac{aV}{L} \right) dV$$

$$= \frac{R_B ab^3}{3EIL} - \frac{wab^4}{8EIL}$$

Substituting for R_B and setting $Q = 0$

$$\frac{1}{EI} \int M_2 \frac{\partial M_2}{\partial Q} dv = \int \frac{wb(a + 1/2b)}{L} \int \frac{ab^3}{3EIL} - \frac{wab^4}{8EIL}$$

$$= \frac{5a^2b^4 + ab^5}{24EIL^2} w \quad \dots\dots(3)$$

Deflection at point D:

Recalling eq (1) . (2) and (3) we have

$$Y_D = \frac{wab^3}{24EI L^2} [4a^2 + 5ab + b^2]$$

$$= \frac{wab^3}{24EI} [4a + b][a + b]$$

$$Y_D = \frac{wab^3}{24EI} [4a + b] \dots\dots(4)$$

Substituting the values of w,a,b,E,I and L we obtain

$$Y_D = 12.72 \text{ mm} \downarrow$$

4. For the uniform loaded beam with following supports. Determine the reactions at the supports

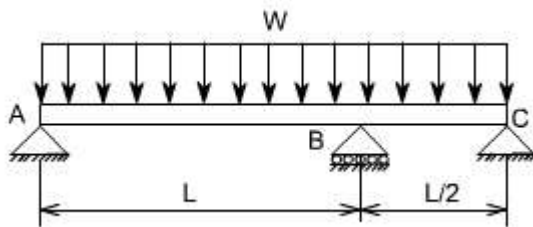

Solution:

Ans.

$$R_A = \frac{13}{32} WL$$

$$R_B = \frac{33}{32} WL$$

$$R_C = \frac{WL}{16}$$