

**A LABORATORY MANUAL**

**ON**

**MECHANICAL ENGINEERING LABORATORY I**

**(Pr.2)**

**3<sup>RD</sup> SEMESTER (DIPLOMA)**

**DEPARTMENT OF MECHANICAL ENGINEERING**

**GOVT. POLYTECHNIC JAJPUR, RAGADI**



**State Council for Technical Education and Training,  
Odisha  
Near Raj Bhawan, Unit-8  
Bhubaneswar-751012  
Odisha**

## **SYLLABUS**

Name of the Course: Diploma in Mech/Auto/Aero & Other Mechanical Allied Branches			
Course code:		Semester	3 <sup>rd</sup>
Total Period:	60	Examination	3 hrs
Lab. periods:	4 P/week	Sessional	25
Maximum marks:	75	End Semester Examination:	50

### **COURSE OBJECTIVES**

Students will develop ability towards

- Conducting experimentations to determine properties of a solid material subject to uniaxial loading and impact
- Conducting experimentations towards determining characteristics of a fuel
- Study of equipment employing using fuels.

### **1. Strength of Materials and thermal Laboratory**

1.1 Determine end reactions in a simply supported beam using parallel force apparatus.

1.2 Determination of Young's modulus using Searle's apparatus

1.3 Determination of torsional rigidity of the shaft using torsion testing machine

1.4 Determination of salient points (Young's modulus, yield point, fracture point) from stress-strain curve using Universal Testing Machine

1.5 Determination of hardness number by Rockwell/Vickers hardness testing machine

1.6 Determination of toughness using Impact testing machine (Charpy/Izod)

1.7 Determination of Flash point and fire point

1.8 Joule's experiment

**Programme outcomes (POs) and programme specific outcomes (PSOs) to be achieved through the practical of this course:-**

1. **Basic and Discipline specific knowledge:** Apply knowledge of basic mathematics, science and engineering fundamentals and engineering specialization to solve the engineering problems.
2. **Problem analysis:** Identify and analyse well-defined engineering problems using codified standard methods.
3. **Design/development of solutions:** Design solutions for well-defined technical problems and assist with the design of systems components or processes to meet specified needs.
4. **Engineering Tools, Experimentation and Testing:** Apply modern engineering tools and appropriate technique to conduct standard tests and measurements.
5. **Engineering practices for society, sustainability and environment:** Apply appropriate technology in context of society, sustainability, environment and ethical practices.
6. **Project Management:** Use engineering management principles individually, as a team member or a leader to manage projects and effectively communicate about well-defined engineering activities.
7. **Life-long learning:** Ability to analyse individual needs and engage in updating in the context of technological changes.

PSOs:

**PSO – 1:** Develop the knowledge and skill relevant to Automobile, Thermal and fluid power industries.

**PSO – 2:** Exhibit the ability to make a product related to Mechanical Engineering and allied engineering fields.

## Practical-Course outcome matrix

### COURSE OUTCOMES

After successful completion of the course, the students will be able to

<b>CO1</b>	Estimate end reactions for beams subjected to point loads.
<b>CO2</b>	Determine properties of a solid material subject to uniaxial loading.
<b>CO3</b>	Compute the torsion and impact strength using respective test setup.
<b>CO4</b>	Compute the tensile and shear properties of materials using UTM.
<b>CO5</b>	Conduct experiments towards determining characteristics of a fuel.
<b>CO6</b>	Analyze first law of thermodynamics for a closed system.

<b>COs</b>	<b>PO1</b>	<b>PO2</b>	<b>PO3</b>	<b>PO4</b>	<b>PO5</b>	<b>PO6</b>	<b>PO7</b>	<b>PSO1</b>	<b>PSO2</b>
<b>CO1</b>	<b>3</b>	<b>2</b>	<b>2</b>	<b>3</b>		<b>3</b>	<b>1</b>	<b>2</b>	<b>3</b>
<b>CO2</b>	<b>2</b>	<b>2</b>	<b>1</b>	<b>2</b>	<b>2</b>	<b>3</b>	<b>1</b>	<b>2</b>	<b>3</b>
<b>CO3</b>	<b>3</b>	<b>2</b>	<b>2</b>	<b>3</b>	<b>2</b>	<b>3</b>	<b>2</b>	<b>2</b>	<b>3</b>
<b>CO4</b>	<b>3</b>	<b>2</b>	<b>2</b>	<b>3</b>	<b>2</b>	<b>3</b>	<b>2</b>	<b>2</b>	<b>3</b>
<b>CO5</b>	<b>3</b>			<b>2</b>	<b>3</b>	<b>3</b>	<b>1</b>	<b>2</b>	<b>3</b>
<b>CO6</b>	<b>2</b>	<b>2</b>	<b>3</b>	<b>3</b>	<b>2</b>	<b>3</b>		<b>2</b>	<b>3</b>

## EXPERIMENT NO. 1

**Aim of the experiment:** Determination of end reactions in a simple supported beam using parallel force apparatus.

### Theoretical background:

If a system of coplanar forces acting on a rigid body, keep it in equilibrium then the algebraic sum of their moments about any point in their plane is zero.

Consider a beam simply supported at the ends and carrying many concentrated loads  
Taking moments about  $R_b$ , we get

$$R_a \times l = W_1(l - a) + W_2(l - b) + W_3(l - c)$$

$$R_a = W_1\left(1 - \frac{a}{l}\right) + W_2\left(1 - \frac{b}{l}\right) + W_3\left(1 - \frac{c}{l}\right)$$

$$R_a = (W_1 + W_2 + W_3) - \frac{1}{l}(W_1a + W_2b + W_3c) \dots\dots\dots(1)$$

$$R_b = (W_1 + W_2 + W_3) - R_a \dots\dots\dots(2)$$

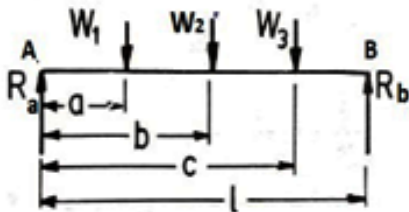

### Experimental set up:

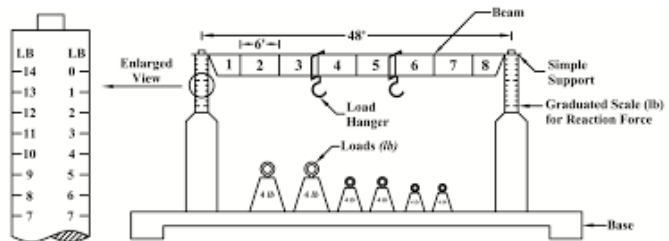

**Resources required:**

Sl.no	Name of the apparatus	Specification
1	Parallel force apparatus	Consisting of two digital weighing machine, steel bars with grooves for hanging weight. Complete with wooden scale, hooks and weights.
2	weights	100/500gms steel weights
3	Hangers	2 Nos

**Procedure:**

1. Measure the distance L
2. Note the zero error in the compression balances.
3. Place the beam on digital weighing balances and reset the weighing scale reading to zero.
4. Suspend different loads  $W_1, W_2$  &  $W_3$  at a distance a, b & c
5. Note the reaction on the beam given by the readings of compression balances ( $r_a$  &  $r_b$ )
6. Calculate  $R_a$  &  $R_b$  values from equation (1) and (2).
7. Repeat the experiment by taking different positions of  $W_1, W_2$  &  $W_3$ .
8. Find out % error between calculated and observed reading.

**Precautions:**

1. Zero error of the compression balance must be taken in to account.
2. Weights should not be put on the beam with a jerk.
3. Slightly press the beam to remove any frictional resistance at the supports before taking the readings.
4. All the distances a, b, c and l should be measured accurately.
5. Readings of spring balances at A & B should be taken accurately.

**Observations:**

SL NO	Weights on beam and their distance from point A						Final reading at A & B		Reactions from calculations		% Error in $R_a$ & $R_b$	
	$W_1$	$W_2$	$W_3$	a	b	c	$r_a$	$r_b$	$R_a$ calculated	$R_b$ calculated	%Error $R_a$	%Error $R_b$
1												
2												
3												

**Results:** The end reactions for simple supported beam (actual) is found to be .....

The end reactions for simple supported beam (actual) is found to be .....

**Conclusions and recommendations if any:**

**Practical related questions:**

1. What does a simply supported beam do?
2. What is SFD and BMD?
3. How do you take a moment of a beam?
4. What is effective length of a beam?
5. In simply supported beam deflection is maximum at \_\_\_\_\_

## EXPERIMENT NO. 2

**Aim of the experiment:** Determination of Young's Modulus using Searl's Apparatus.

### Theoretical background:

#### Stress:-

It is defined as the ratio between the load and cross-sectional area of the given specimen. It may be defined as force per unit area.

Mathematically,

$$\text{Stress} = \text{load/area}, \sigma = (P/A)$$

Unit of stress is  $N/M^2$  or  $KN/M^2$

#### Strain:-

It is defined as the ratio between the change in the length to its original length of the given specimen.

Mathematically,

$$\text{Strain} = \text{change in length/original length}$$

$$e = \delta/l, \text{ It has no unit.}$$

#### Young's modulus:-

It is the ratio between stress and strain. Sometimes referred to as the modulus of elasticity. It is a mechanical property that measures the stiffness of a solid material. It quantifies the relationship between tensile stress and axial strain in the linear elastic region of a material.

Mathematically,

$$\text{Young's modulus} = \text{stress/strain} = E = \sigma/e$$

Its unit is  $KN/M^2$  or  $N/M^2$ .

### Experimental set up:

#### Technical Specification:

Diameter of copper wire (d) =            m<sup>2</sup>

Cross-sectional area of the specimen (A) =  $(\pi/4) \times D^2 = \dots\dots\dots M^2$

Original Length of copper wire (L) =            m



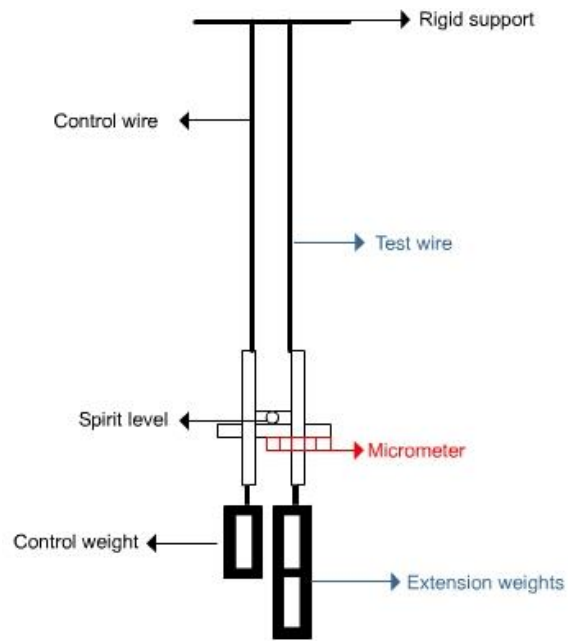

**SEARL'S APPARATUS**

**Resources required:**

SL NO.	NAME OF THE APPARATUS	SPECIFICATION
01	Searl's apparatus	
02	Vernier caliper	L.C =0.02mm
03	Steel rule	l.c =0.5mm
04	Copper wire	D =0.001mm
05	Balancing weight	1Kg
06	Weight pan	
07	Plier	

**Procedure:-**

1. Take two copper wires of requisite length.
2. Hang the searl's apparatus by the two copper wires of which one wire is fixed wire and another is testing wire.
3. Now measure the diameter and length of the wire.
4. Then set the weight pan in the testing side.
5. Then give some load in the load pan. The wire will elongate.
6. Now write down the load applied and the change in length in the observation table.
7. Then gradually increase the loads and take at least five readings.

**Precautions if any:**

1. Weight (load) should be applied gradually.
2. Always maintain the spirit level horizontal with the base
3. Avoid errors during measurement of length, diameters, etc.
4. Over loading should be avoided.

**Observation table and calculation:**

SL.NO	Load applied(P)kg	Stress( $\rho$ ) (P/A)	Change in length( $\Delta L$ )m	Strain(e) ( $\Delta L/L$ )	Yooung's modulus( $\sigma/e$ )
1					
2					
3					
4					
5					

**Result:** young's modulus of the given specimen is found to be .....

**Practical related questions:**

1. Explain stress and its unit.
2. Define young's modulus and state its significance.
3. Why we use two wires in searle's apparatus?
4. Is it necessary that both wires should be of same material and same length?
5. How temperature affects young's modulus?
6. Which is more elastic, a rubber or steel?

### EXPERIMENT NO.3

**Aim of the experiment:** Determination of torsional rigidity of the shaft using torsion testing machine

#### Theoretical background:

Materials commonly used in the manufacturing industry, such as metal fasteners and beams are often subjected to torsion; hence determination of their strength under twisting is necessary. Without torsion test, materials would not be properly vetted before being launched for commercial use. In torsion test the measurable values include the modulus rigidity, yield shear strength, ultimate shear strength and modulus of rupture in shear.

The value of modulus of rigidity can be found out through observations, made during the experiment and by using the torsion equation.

The torsion equation is:-  $T/J = G.\theta/L$ .

$$\text{So, } G = T.L / J.\theta$$

Where,

T=Torque applied.

$$J = \text{Polar moment of inertia} = \frac{\pi}{32} \times d^4$$

d= Diameter of specimen.

C=Modulus of rigidity.

$\theta$ =Angle of twist.

L=Gauge length of the specimen in m.

#### Diagram/set up:

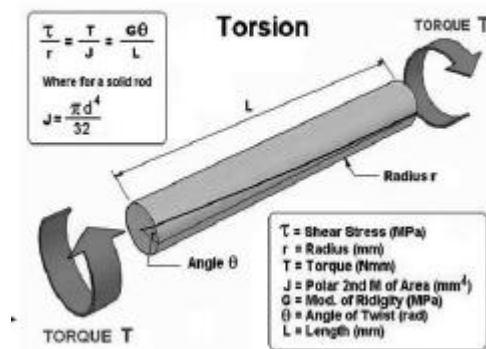

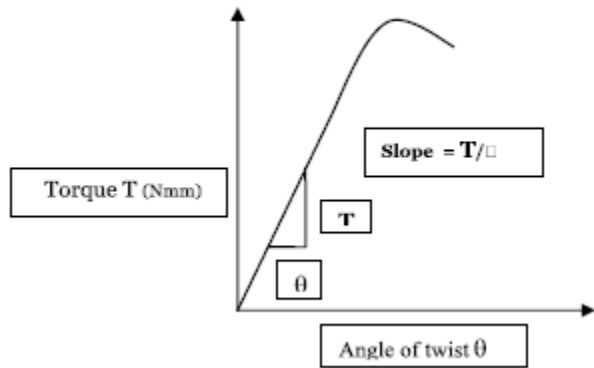

**Torsion testing machine**

**Recourses required:**

Sl.no	Name of the apparatus	Broad specification
01	Torsion testing machine	Make: Enkay .Max. torque capacity: 200.Torque range: 200,100,50. No of divisions on dial: 500.Clearance between grips: 0-420mm. Grips for round specimen: 7-10,10-15,15-20mm. Grips for flat specimen width: 3-10,30mm. Motor: 440v/3 phase/50HZ/0.5HP. Fixed with auto torque selector to regulate torque ranges, contains geared motor to apply torque to specimen. Torsion and twist test on various metal rods and flats, torque measurement by pendulum dynamometer system. One of the grips shall be capable of being rotated around the axis of the test piece while the other shall not be subjected to any angular deflection. The distance between the grips shall be capable of adjustment for different lengths.
02	Mild steel specimen	D=..... L=.....
03	Steel rule	Least count=0.5mm
04	Vernier caliper	Least count=0.02mm

**PROCEDURE:-**

1. Select the driving dogs to suit the size of the specimen and clamp it in the machine by adjusting the length of the specimen by means of a sliding spindle.
2. Measure the diameter of the specimen at about three places and take the average values.
3. Choose the appropriate range by capacity change lever.
4. Set the maximum load pointer to zero.
5. Set the protractor to zero for convenience.
6. Carry out straining by rotating one of the ends with hand wheel or electric motor in either direction.
7. Record the readings of torque and angle of twist (T &  $\theta$ ).
8. Continue to test the sample for the destruction with increasing values of strain. Record the values of T&  $\theta$  upto fracture.
9. Plot a torque verses angle of twist graph.
10. Read off coordinates of a convenient point from the straight line portion of the graph and calculate the value of the modulus of rigidity by using torsion equation.

**Precautions to be followed:**

1. Avoid over acceleration of machine and maintain proper rate of loading.
2. Place the sample exactly at the required location only and fix properly.
3. Keep safe distance from the machine during operation
4. The grips having requisite hardness and straight faces must be used.
5. The grips should not apply any bending force to the test specimen.

**Observations and calculations:**

Material of the sample:-.....

Diameter of the sample,

$$d_1 = \dots\dots\dots\text{mm}, d_2 = \dots\dots\dots\text{mm}, d_3 = \dots\dots\dots\text{mm}$$

Average dia = .....mm

Gauge length of the sample = .....mm

**Observations during experiments:**

Sl.no	Torque (T) in N-mm	Angle of twist ( $\theta$ )	
		$\theta$ in degrees	$\theta$ in radians

**Sample calculations:**

Polar moment of inertia ( $J$ ) =  $\frac{\pi}{32} \times d^4 = \dots\dots\dots \text{mm}^4$

Plot T vs  $\theta$  graph from above readings and find out the slope of the graph (in elastic region)

From torsion equation, we know that  $G = T.L/J.\theta$

$G = (\text{slope of the graph } T \text{ vs } \theta) \times (L/J) = \dots\dots\dots \text{N/mm}^2$

**Result:** modulus of rigidity of given sample specimen is found to be .....

**Practical related questions:**

1. Calculate modulus of rigidity of the same sample material for 100mm dia and 1m length.
2. Define torque and state the relation between torque and angle of twist.
3. What is the purpose of torsion test?
4. Why do we choose mild steel as our specimen material?
5. Which section(round, square, rectangular and open) is best in torsion?

## EXPERIMENT NO.4

**Aim of the experiment:** Determination of Salient points (Young's Modulus, Yield Point, Fracture point) from stress –strain curve using Universal Testing Machine (UTM).

### Theoretical background:

The tensile test is most applied one, of all mechanical tests. In this test ends of test piece are fixed into grips connected to a straining device and to a load measuring device. If the applied load is small enough, the deformation of any solid body is entirely elastic. An elastically deformed solid will return to its original form as soon as load is removed. However, if the load is too large, the material can be deformed permanently. The initial part of the tension curve(stress-strain curve) which is recoverable immediately after unloading is termed as elastic zone and the rest of the curve which represents the manner in which solid undergoes plastic deformation is termed plastic zone. The stress below which the deformations essentially entirely elastic is known as the yield strength of material. In some material the onset of plastic deformation is denoted by a sudden drop in load indicating both an upper and a lower yield point. However, some materials do not exhibit a sharp yield point. During plastic deformation, at larger extensions strain hardening cannot compensate for the decrease in section and thus the load passes through a maximum and then begins to decrease. This stage the “ultimate strength” which is defined as the ratio of the load on the specimen to original cross-sectional area, reaches a maximum value. Further loading will eventually cause ‘neck’ formation and rupture.

**Stress:** when a material is subjected to external loading, then the internal resistance per unit cross section, set up in the material to deformation is called as stress.

**Ultimate tensile strength** of a material is maximum load carrying capacity of the material per unit cross sectional area in tension.

**Tensile strain:** change in length/original length.

**Hooke's law:** within elastic limit, stress is directly proportional to strain.

**Modulus of elasticity:** the ratio of stress to strain within elastic limit.

**Percentage of elongation:** the percentage change in gauge length with reference to the original gauge length.

**UTM machine** is designed for testing metals and other materials under tension, compression, bending, transverse and shear loads. The Straining/Loading Unit consists of a hydraulic cylinder, an electrical geared motor coupled to a chain sprocket drive and a table coupled with the ram of the hydraulic cylinder mounted on a robust and rigid cast iron base. The cylinder and the ram are individually lapped to eliminate friction. The upper cross-head is rigidly fixed to the table by straight, hard chrome plated steel columns. The lower cross head is connected to two precision threaded (screwed) columns which are driven by an A.C. Induction motor.



**Block diagram/set up:**

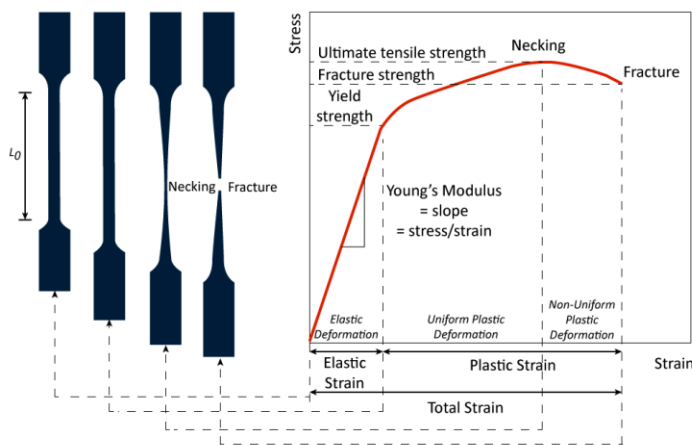
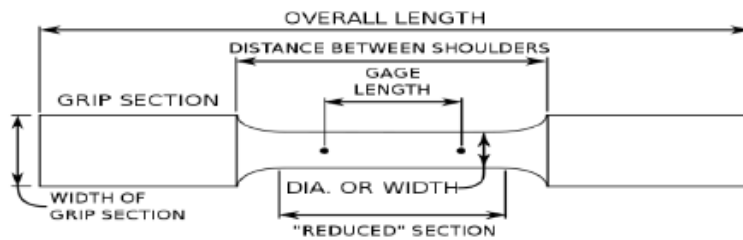

**Resources required:**

Sl.no	Apparatus	specification
1	Universal Testing Machine	Servo hydraulic fully computerized, capacity: 400kN. Motorized control valve, straining at variable speeds, motor driven threaded column, RS 232 serial port for PC control, measuring range: 0-400kN, load resolution: 20kN, clearance between columns: 500mm, 440 volt, 50Hz, 3 phase power supply. Hydraulic oil: 67,68 grade,
2	Vernier calliper	I.c = 0.02
3	Steel rule	I.c = 0.5
4	Mild steel specimen	D=..... L=.....

**Procedure:**

1. Measure the original length and diameter of the specimen. The length may either be length of gauge section which is marked on the specimen with a preset punch or the total length of the specimen.
2. Ensure that the release valve and the control valve mounted on control unit are closed.
3. Put the electric switch on. Move the lower crosshead up or down with the help of UP/DN press button on control unit to adjust the space with the length of the specimen.
4. Insert the specimen into grips of the machine and fix it tightly.
5. Put all the required data in software install in PC for the given specimen and save it.
6. Begin the load application by pressing the start button on control unit and at the same time click on start button on PC. Slightly open the control valve.
7. Record the maximum load. Observe the decrease in load and neck formation on the specimen.
8. Record the load at fracture and observe the load vs displacement graph. Then switch off the machine.
9. Close the control valve and open the release valve.
10. Remove the specimen and observe the cup and cone formation at the fracture point.
11. Rejoin the two pieces and measure the final gauge length and reduced diameter.
12. Take notes for yield stress, ultimate stress and fracture point stress from the load vs displacement graph.
13. Calculate slope of the graph which will give modulus of elasticity.

**Precautions if any:**

1. Avoid over loading and maintain proper rate of loading.
2. Place the sample exactly at the center of the grips of the crossheads.
3. Keep safe distance from machine during operation.
4. Open the release valve after the machine is switched off.
5. Keep distance from electric wires.

**Observations:**

- (a) Initial diameter of specimen = .....
- (b) Initial gauge length of specimen = .....
- (c) Load at yield point = .....
- (d) Ultimate load = .....

- (e) Breaking load =.....
- (f) Ultimate load after specimen breaking =.....
- (g) Final length after specimen breaks =.....
- (h) Diameter of specimen after breaking takes place =.....

**Calculations:**

1. Cross sectional area =  $\frac{\pi}{4} d^2 = \dots\dots\dots\text{mm}^2$
2. Cross sectional area after breaking of specimen =..... $\text{mm}^2$
3. Yield stress = yield load / Cross sectional area =..... $\text{N/mm}^2$
4. Ultimate stress = ultimate stress / Cross sectional area =..... $\text{N/mm}^2$
5. Breaking stress = breaking load / Cross sectional area = ..... $\text{N/mm}^2$
6. Actual breaking stress = breaking load / reduced Cross sectional area =..... $\text{N/mm}^2$
7. Stress (within elastic limit) = ..... $\text{N/mm}^2$
8. Corresponding strain =.....
9. Young's modulus = stress / strain =..... $\text{N/mm}^2$

**Results:**

1. Young's modulus =.....
2. Yield stress =.....
3. Fracture / breaking stress =.....

**Practical related questions:**

1. Draw and explain stress strain diagram for ductile as well as brittle materials.
2. What is factor of safety?
3. Write down the various types of test that can be conducted in your UTM.
4. Compare elastic modulus of rubber with that of plastic.

## EXPERIMENT NO.5

**Aim of the experiment:** Determination of hardness number by Rockwell hardness testing machine.

### Theoretical background:

Rockwell hardness test differs from Brinell hardness test in that the hardness is determined from the depth of indentation made by the indenter under a constant load. Various types of indenters may be used in Rockwell hardness tests: diamond indenter and steel-ball indenters of diameter 1/16, 1/8, 1/4, or 1/2 inch. In this test, the indenter is pressed into the specimen surface under an initial minor (light) load followed by a major (heavy) load. The additional depth of indentation made by the indenter under the major load beyond that by the minor load is measured and converted to a hardness number.

The hardness number is inversely related to the depth of indentation. In regular Rockwell hardness tests, the minor load is always 10 kg while the major load can be 60, 100, or 150 kg. A letter is assigned to each scale that employs a particular combination of indenter and major load. A hardness number is suffixed by first the letter H (for hardness), then the letter R (for Rockwell), and finally the letter that indicates the scale used. For example, a value of 45 on the Rockwell C scale is expressed as 45 HRC.

Rockwell hardness tester gives the direct reading of hardness number on a dial provided with the machine. The specimen may be cylinder, cube, thick or thin metallic sheets.

Type of specimen	Type of Indentor	Scale	Total load(P) Kg-F
Hard Metals	Diamond cone	C (Black graduations)	150
Soft Metals	Ball (1/16")	B (Red graduations )	100

### Block diagram/set up:



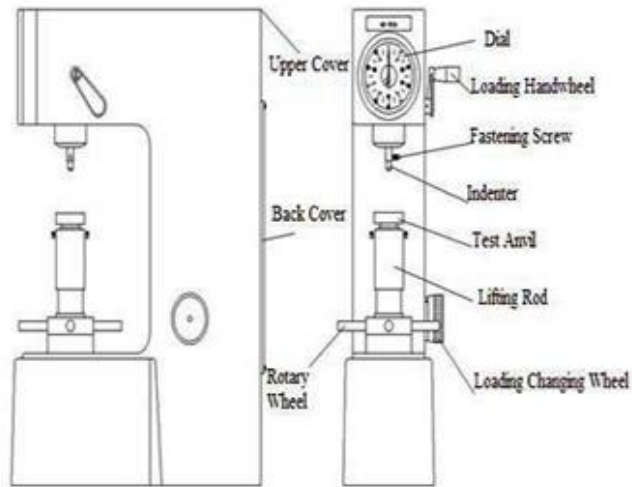

**Resources required:**

Sl.no	Apparatus	specification
1	Rockwell hardness testing machine	
2	Indentor	
3	Weights	
4	standard specimen	

**Procedure:**

1. Turn power switch located in lower rear panel "ON".
2. Select desired scale by means of the "TEST SCALE SCROLL". This key may be depressed for each scale advancement or held in for rapid scrolling.
3. Select and install the proper indenter, as indicated in the "PENETRATOR" display.

4. Select the proper major load, as indicated in the "MAJOR LOAD kg" display, by means of the weight selector dial.
5. Place the specimen on the anvil.
6. Raise specimen into contact with the indenter by turning capstan hand wheel clockwise slowly. The bar LEDs (red) will light up and the read display will show "MINOR LD".
7. Continue to slowly turn the capstan hand wheel. Stop the hand wheel when the bar LEDs reach the "SET" zone. The major load will automatically be applied and then removed. The read display will show "TESTING" and then the numerical value and the scale tested.
8. Remove the minor load by turning the capstan hand wheel counter-clockwise. Continue to lower the specimen until it clears the indenter. The test is concluded.

**Observations:**

S.N	Material	Thickness	Scale	Type of Indenter	Minor Load	Major Load	Measured Hardness			Average Rockwell Hardness
					kgf	kgf	1	2	3	
1										
2										
3										

**Results:**

## EXPERIMENT NO.5

### BRINELL HARDNESS TEST

**AIM:** To determine the hardness of the given specimen using Brinell hardness test.

**Theoretical Background:** The method of hardness testing was introduced by J.A. Brinell in 1900. In this test, a standard hardened steel ball (dia D) is indented into the surface of the specimen by a gradually applied load (P) which is maintained on the specimen for definite time (usually 10 or 15 sec). Ball of 10 mm, 5 mm, and 2.5 mm are generally used. The diameter of the impression or indentation (d) is measured by microscope and the Brinell hardness number (B.H.N.) is found out by following formula.

$$\text{BHN} = \frac{\text{Load Applied (kgf)}}{\text{spherical surface area of indentation}}$$

$$\text{BHN} = \frac{2P}{\pi D(D - \sqrt{D^2 - d^2})}$$

**Experimental set up:**

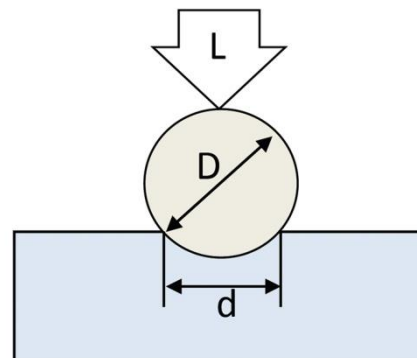

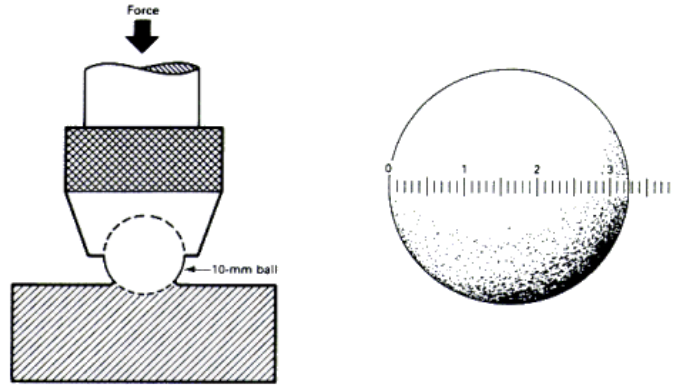

### Resources required:

Sl.no	Apparatus	specification
1	Brinell hardness testing machine	Load range: 250kgf upto 3000kgf, max test height: 410mm, depth of throat: 200mm, net weight: 500kg, height: 1185mm, size: 650 x 670 mm, drive: electric motor 0.33/0.5 HP, flanged mounted, 440v/50hz/3 phase power supply, max depth of spindle: 180mm, solid vibration free base.
2	Required accessories	Loading pan and loose weights (each equivalent to 250kgf), one testing table, spanner, screw driver, brinell microscope.
3	Indenter	5mm, 10mm dia ball indenter type
4	standard specimen	Mild steel, Al, Cu, etc

### Procedure:

1. Insert ball of diameter 'D' in the ball holder of machine.
2. Make the specimen surface clean by oil, grease, dust etc.
3. Make contact between the specimen surface and ball using jack adjusting wheel.
4. Push the required button for loading.
5. Pull the load release level and wait for 15 seconds.
6. Remove the specimen from the support table and locate the Indentation.
7. View the indentation through microscope and measure the diameter 'd' of the indentation using micrometer fixed on the microscope.
8. Repeat the procedure and take three readings.



**Precautions:**

1. Apply the load slowly and gradually on the sample.
2. Distance between old impression and location for new impression should be 3D (three times the ball diameter)
3. After applying the specified load wait for 15 sec then remove the load.
4. The thickness of the test piece must not be less than 8 times the depth of impression.
5. The surface on which the Brinell impression is to be made should be sufficiently smooth and clean.

**Observations:**

S.N.	Test specimen material	Dia. of indenter D mm	Applied load Kgf(F)	Diameter of indentation (d) mm			Average diameter (d)mm	Brinell Hardness Number
				1	2	3		
1								
2								
3								

**Calculation:**

$$\mathbf{BHN} = \frac{\mathbf{Load\ Applied\ (kgf)}}{\mathbf{spherical\ surface\ area\ of\ indentation}}$$

$$\mathbf{BHN} = \frac{\mathbf{2P}}{\mathbf{\pi D(D - \sqrt{D^2 - d^2})}}$$

**Result :** The brinell hardness number of the given sample is found to be .....

**Practical related questions:**

1. State the difference between Hardness & Hardenability?
2. Describe the surface conditions necessary for Brinell hardness testing.
3. List the different types of indenters used in hardness testing?
4. List the materials which cannot be tested by Brinell hardness tester
5. State the reason for using ball indentors of different diameter for Brinell hardnesstesting

## EXPERIMENT NO.6

**Aim of the experiment:** Determination of toughness by using impact testing machine (izod/charpy)

### Theoretical background:

Several engineering materials have to withstand impact or suddenly applied loads while in service. These loads are applied suddenly. The stress induced in these components is many times more than the stress produced by same load applied gradually. Therefore, impact tests are performed to assess shock absorbing capacity. Impact test signifies toughness of material that is ability of material to absorb energy during impact. Toughness takes into account both the strength and ductility of the material.

Two types of notch impact tests are commonly used. 1. Charpy test 2. Izod test.

In izod test, the specimen is placed as cantilever beam. The specimen have V shaped notch of  $45^\circ$ . The notch is located on tension side of specimen during impact loading.

In charpy test, the specimen is placed horizontal simply supported beam. The specimen have V shaped notch of  $45^\circ$  at the centre of the length. The notch is located on tension side of the specimen during impact loading.

Energy absorbed in joules = initial energy in joules – final energy in joules

	Charpy Impact Testing	Izod Impact Testing
<b>Materials Tested</b>	Metals	Plastics & Metals
<b>Types of Notches</b>	U-notch and V-notch	V-notch only
<b>Position of the Specimen</b>	Horizontally, notch facing away from the pendulum	Vertically, notch facing toward the pendulum
<b>Striking Point</b>	Middle of the sample	Upper Tip of the sample
<b>Common Specimen Dimensions</b>	55 x 10 x 10 mm	64 x 12.7 x 3.2 mm (plastic) or 127 x 11.43 mm round bar (metal)
<b>Common Specifications</b>	ASTM E23, ISO 148, or EN 10045-1	ASTM D256, ASTM E23, and ISO 180

## Experimental set up:

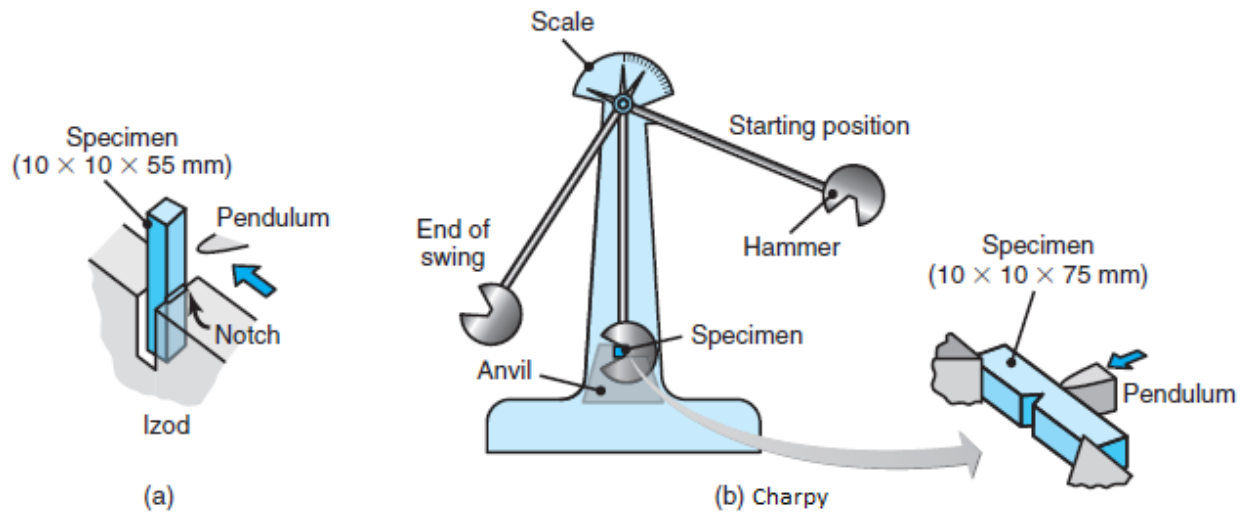
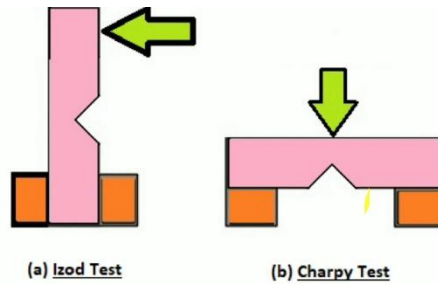

## Resources required:

Sl.no	Name of the apparatus	Specification
01	Impact testing machine	Max capacity: 300J/170J, minimum scale graduation: 0.5J, overall size: 1.32m x 0.45m x 1.05m, net weight: 375kg, standard accessories, basic machine with hammer pipe, charpy and izod striker, protective railing, hand brake and stopper – 1set., digital display unit , caliper gauge for checking V notch, izod support for izod round specimen, self centering tong for quick and accurate setting of charpy test specimen.
02	Sample specimen	Mild steel, high carbon steel, dimensions given as in set up diagrams.
03	Vernier calliper	l.c =0.02
04	Tools and equipment used for specimen preparation and setting	Vice, hacksaw, files, gauges, players

## Procedure:

1. For conducting charpy test, a proper striker is to be fitted firmly to the bottom of the hammer with the help of the clamping piece.
2. Bring the Hammer to its initial position of striking ( $140^{\circ}$ ) and strike without placing any specimen. Take the reading in digital indicator. This will give the initial energy reading. Keep in mind that there must be no person in the range of swinging hammer/ pendulum. Apply pedal brake after one swing to stop the oscillation.
3. Bring back the hammer to its initial striking position again and lock it.
4. The prepared specimen of required dimensions is then placed horizontally on vice with the V notch facing opposite to the striking face of the hammer.
5. Then release the hammer for striking the specimen. Take the final energy reading. The difference between initial and final reading will give the actual energy absorbed.
6. Similar procedures can be followed for izod test to measure the initial energy reading. Here hammer is released from  $85^{\circ}$ .
7. The specimen for izod test is then firmly fitted in the specimen support with the help of clamping screw and élan key. Care should be taken that the notch on the specimen should face to pendulum striker.

8. After ascertaining that there is no person in the range of swinging pendulum, release the pendulum to smash the specimen. Carefully operate the pendulum brake when returning after one swing to stop the oscillations.
9. Note down the final reading and determine the actual energy absorbed.

The notch impact strength depends largely on the shape of the specimen and the notch. The values determined with other specimens therefore may not be compared with each other.

**Precautions:**

1. Avoid improper handling of the equipments.
2. Prepare the specimen exactly as per dimensions.
3. While locking the hammer pay extra care.
4. While releasing the hammer for impact make sure that there is no person standing around the machine.
5. Set the digital display for either izod or charpy while performing the respective testings.

**Observations:**

Sl. no	Energy absorbed by the specimen (izod/charpy)
1	
2	
3	

**Results:**

Izod/charpy impact value for specimen no.1 = .....

Izod/charpy impact value for specimen no.2 = .....

Izod/charpy impact value for specimen no.3 = .....

**Practical related questions:**

1. List any two machine components that are subjected to impact loads.
2. What do you mean by toughness?
3. What do you mean by resilience and how it is different from toughness?
4. What is the necessity of making notches in the specimen?
5. Why it is necessary to perform impact test on a material?

## **EXPERIMENT NO.7**

**Aim of the experiment:** Determination of flash point and fire point

**Theoretical background:**

### **Flash Point:-**

The flash point of any fuel is the lowest temperature at which it can vaporize to form an ignitable mixture in air. At flash point the vapor may easily burn if the source of ignition is removed. The flash is not to be confused with auto ignition temp. Which does not require an ignition source.

### **Fire Point:-**

The fire point of a fuel is the temperature at which it will continue to burn for at least 5 sec. After ignition by an open flame, fire point can be assumed to be about 10° C higher than the flash point.

The flash and fire points of a liquid fuel specimen are the indicators of its flammability. In general, flash point is the lowest temperature of the test specimen, corrected to a barometric pressure of 101.3 kPa, at which the application of an ignition source causes the vapor of the test specimen to ignite momentarily and the flame to propagate across the surface of the liquid under the specified conditions of test. It is important to realize that the value of the flash point is not a physical constant but is the result of a flash point test and is dependent on the apparatus and procedure used. Fire point may be considered as the lowest temperature of the liquid at which vapor combustion and burning commences. A fire point happens when an ignition source is applied and the heat produced is self-sustaining, as it supplies enough vapors to combine with air and burn even after the removal of the ignition source.

Flash and fire point in engine perspective Gasoline has a flash point around -43° C whereas diesel has flash points higher than 52° C. Lower flash points are the indicators of good flammability and volatility. Therefore, gasoline makes faster vapour formation than diesel and instantly catches fire when spark, an external flame source, is provided. However, as its autoignition temperature is high (in low compression ratio gasoline engine perspective), which is in the order of 247-280° C, it does not ignite prematurely due to the residual heat generated during compression stroke and heat transfer from wall. On the contrary, the higher flash point of diesel indicates poor vaporization tendencies and lesser tendency to ignite subjected to external flame source. However, as the autoignition temperature of diesel is low (in high compression ratio diesel engine perspective), which is in the order of 210° C, diesel autoignites easily with the residual heating during compression stroke and heat transfer from wall without the need of an external flame source such as spark plug. Poor vaporization tendency of diesel is dealt with in-cylinder swirl and high pressure injection. Vegetable oils have significantly high flash points which are in the order of diesel fuels and higher. Hence their vaporization and mixing are a huge challenge for direct engine applications. Therefore, vegetable oils are transesterified to produce fatty acid methyl esters or biodiesel which has comparable flash point for direct compression

ignited diesel engine application. In the alcohol category, methanol has a flash point of around 12° C and autoignition temperature of 470° C. Similarly, ethanol has 16° C flash point and autoignition temperature around 365° C indicating their close proximity to gasoline fuel and potential alternative fuel application in spark ignited engines.

**Apparatus and consumables required:**

- a) A Pensky-Martens flash point apparatus.
- b) Thermometer of suitable range.
- c) Test samples.

**Pensky-Martens's Flash Point apparatus**

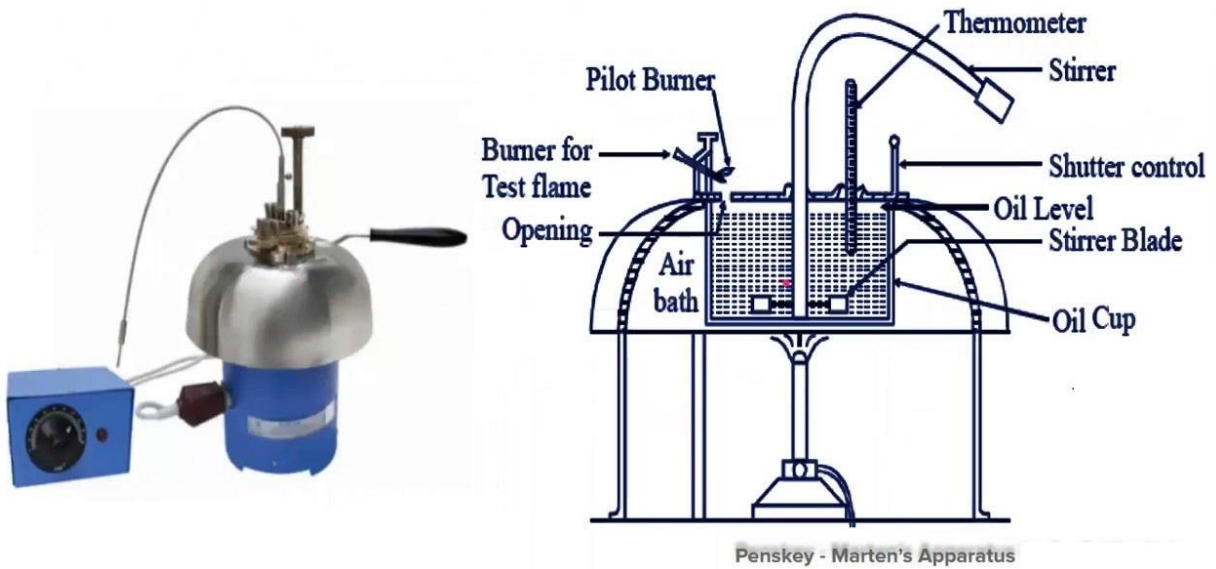

**Preparation of samples:**

- a) Samples should be in reasonably fluid state before testing. For asphalts and other viscous materials, preheating should be done to ensure fluidity before testing.
- b) Samples may be warmed with constant heating rate. However, under no circumstances, should be heated above a temperature that lies 16° C below the expected flash point.
- c) Samples containing dissolved water may be dehydrated with calcium chloride or by filtering through a suitable filter paper. If the same is not done, its consequence on experimental results and repeatability should be duly inferred.



**Procedure:**

1. Clean and dry all parts of the cup thoroughly.
2. Fill the cup with the sample to be tested to the level indicated by the filling mark.
3. Place the lid on the cup and set the latter on the stove.
4. Insert the thermometer and supply heat with the help of the rheostat switch to ensure temperature rise rate not more than 5 to 6° C per minute.
5. Turn the stirrer with 90 to 120 rpm in a downward direction.
6. Provide the test flame time to time and start nearly 17° C below the expected flash point of the sample with 0.5 to 1° C gap.
7. Lower the test flame to the vapour space of the cup for 5s and allow it to be there for 1s. After that move the test flame up as quickly as possible and shut down the lid for vapour build up.
8. Do not stir the sample while providing the test flame.
9. Denote the flash point and fire point accordingly.

**Observations:**

Types of fuel	Flash point	Fire point
Petrol		
Diesel		
Kerosene		

**Results:**

**Practical related questions:**

1. The lowest temperature at which the oils gives enough vapour is .....
2. The fire point is the lowest temperature at which the vapour of oil burns continuously for at least \_\_\_\_\_ when a small flame is brought near to it.
3. The fire point of an oil is about \_\_\_\_\_ higher than the flash point.
4. Pensky-Marten's apparatus is used to find out the \_\_\_\_\_
5. Oil cup in Pensky-marten's apparatus is made with \_\_\_\_\_

## EXPERIMENT NO.8

**Aim of the experiment:** Joules Experiment.

1. Study of Joules experiment to validate first law of thermodynamics
2. The main aim of Joules Experiment was to determine the relationship between the work done and the quantity of heat produced in mechanical system.

### Theoretical background:

James P. Joule carried out his famous experiment; he placed known amounts of water, oil, and mercury in an insulated container and agitated the fluid with a rotating stirrer. The amounts of work done on the fluid by the stirrer were accurately measured, and the temperature changes of the fluid were carefully noted. He found for each fluid that a fixed amount of work was required per unit mass for every degree of temperature rise caused by the stirring, and that the original temperature of the fluid could be restored by the transfer of heat through simple contact with a cooler object. In this experiment you can conclude there is a relationship between heat and work or in other word heat is a form of energy.

### Internal Energy

Through, Joule experiment what happen to energy between time it is added to water as work, and time it is extracted to heat? Logic suggests that this energy contained in the water in another form which called *internal energy*.

Internal energy refers to energy of molecules of substance which are ceaseless motion and possess kinetics energy. The addition of heat to a substance increases this molecular activity, and thus causes an increase in its internal energy. Work done on the substance can have the same effect, as was shown by Joule. Internal energy cannot be directly measured; there are no internal-energy meters. As a result, absolute values are unknown. However, this is not a disadvantage in thermodynamic analysis, because only changes in internal energy are required.

$$U = f(T, V)$$
$$\partial u = \left( \frac{\partial U}{\partial T} \right)_V \partial T + \left( \frac{\partial U}{\partial V} \right)_T \partial V$$
$$\int_{u_1}^{u_2} \partial U = \int_{T_1}^{T_2} \left( \frac{\partial U}{\partial T} \right)_V \partial T + \int_{V_1}^{V_2} \left( \frac{\partial U}{\partial V} \right)_T \partial V$$
$$\Delta U = \int_{T_1}^{T_2} C_v dT + \int_{V_1}^{V_2} \left( \frac{\partial U}{\partial V} \right)_T \partial V$$

In case of case ideal gas  $\left( \frac{\partial U}{\partial V} \right)_T = 0$ , and this lead to

$$\Delta U = \int_{T_1}^{T_2} C_v dT$$

### Construction and Working:

The layout of Joule's experiment is as shown in the figure.

1. Paddle wheel 2 was submerged in the heat-insulated vessel 1 to the walls of which vanes 3 were fastened, the vanes interfering with the motion of oil due to rotation of the paddle.
2. Rotation was imparted to the paddle (stirrer) by the falling load 4 of weight  $G$ , connected to the paddle by means of a rope and pulley 5.
3. As the weight falls through a distance  $\Delta h$ , the work done by it (and, consequently, by the stirrer) is equal to the decrease in the potential energy of the weight  $G\Delta h$ .
4. The heat liberated in the oil-filled vessel is calculated from the rise in water temperature, measured with a thermometer.

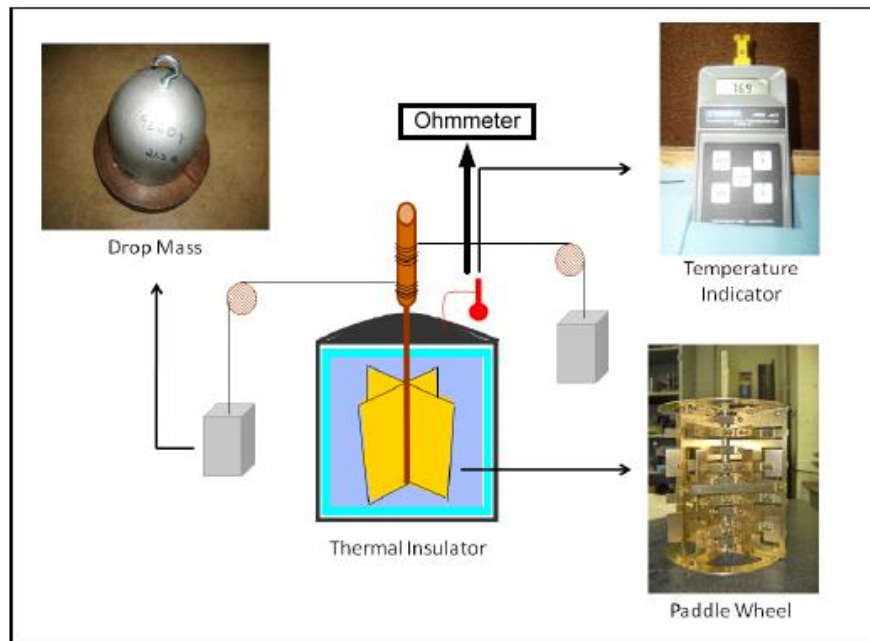
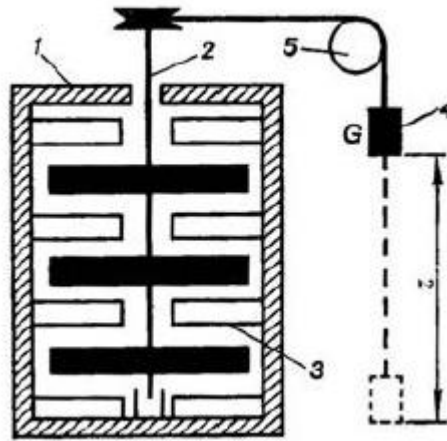

**Observations:-**

1. Weight  $W = (G) = 2\text{kg}$

2. Mass of Oil ( $m$ ) =            **kg**

3. Fall of weight through distance  $z =$             **feet ( m)**

4. Initial Temperature of oil  $T_1 =$              **$^{\circ}\text{C}$**

5. Final Temperature of oil  $T_2 =$              **$^{\circ}\text{C}$**

6. Specific heat of oil  $C_p =$              **$\text{kJ/kgK}$**

**Calculations:**

1. Potential work =  $m g z$  in J

2. Amount of heat produced  $Q = m C_p (T_2 - T_1)$  in J

**Conclusion (Importance) of Joule's Experiments:**

1. Joule's experiments conclusively established that heat is a form of energy.
2. Always the same amount of heat was produced by spending a given amount of mechanical work. It is immaterial what type of arrangement is used for doing mechanical work.
3. It defines the relationship between Joule and Calories.

**Practical related questions:**

1. What was the outcome of the Joule experiment?
2. What is Joule constant?
3. Why is the mechanical equivalent of heat important?
4. State first law of thermodynamics.
5. What do you mean by entropy?

## ASSESSMENT SCHEME

### EXPERIMENT NO: X

REG.NO	NAME	HANDLING OF MACHINE TOOL (3)	CALCULATION AND FINDING RESULT(2)	NEATNESS IN RECORD(2)	VIVA/PRACTICAL QUESTION ANSWERS(3)	MARKS OBTAINED(OUT OF 10)

## SESSIONAL ASSESSMENT

REG.NO	NAME	EXPT 1	EXPT 2	EXPT 3	EXPT 4	EXPT 5	EXPT 6	EXPT 7	EXPT 8	AVG