

STUDY MATERIAL ON
MANUFACTURING TECHNOLOGY
4TH SEMESTER



Prepared by

Manas Kumar Mishra, Lecturer

DEPARTMENT OF MECHANICAL ENGINEERING

GOVT. POLYTECHNIC JAJPUR

PROGRAMME: MECHANICAL ENGINEERING

COURSE: MANUFACTURING TECHNOLOGY (TH1), 4TH SEM

COURSE OUTCOMES:

At the end of this subject Students will be able to:

CO1: Describe the properties and geometry of various cutting tools.
CO2: Demonstrate the working of a conventional as well as CNC lathe machine.
CO3: Explain the working of various reciprocating machine tools.
CO4: Explain the operations performed in conventional as well as CNC milling machines.
CO5: Understand different internal machining operations.
CO6: Interpret the required surface finishing operation.

PSOs:

PSO – 1: Develop the knowledge and skill relevant to Automobile, Thermal and fluid power industries.

PSO – 2: Exhibit the ability to make a product related to Mechanical Engineering and allied engineering fields.

SYLLABUS

CONTENT

1.0 Tool Materials 1.1 Composition of various tool materials 1.2 Physical properties & uses of such tool materials. 2.1 Cutting Tools 2.1 Cutting action of various and tools such as Chisel, hacksaw blade, dies and reamer 2.3 Turning tool geometry and purpose of tool angle 2.5 Machining process parameters (Speed, feed and depth of cut) 2.6 Coolants and lubricants in machining and purpose 3.0 Lathe Machine 3.1 Construction and working of lathe and CNC lathe Major components of a lathe and their function • Operations carried out in a lathe (Turning, thread cutting, taper turning, • internal machining, parting off, facing, knurling) Safety measures during machining • 3.2 Capstan lathe Difference with respect to engine lathe • Major components and their function • Define multiple tool holders • 3.3 Turret Lathe Difference with respect to capstan lathe • Major components and their function • 3.4 Draw the tooling layout for preparation of a hexagonal bolt & bush 4.0 Shaper 4.1 Potential application areas of a shaper machine 4.2 Major components and their function 4.3 Explain the automatic feed mechanism 4.4 Explain the construction & working of tool head 4.5 Explain the quick return mechanism through sketch 4.6 State the specification of a shaping machine. 5.0 Planing Machine 5.1 Application area of a planer and its difference with respect to shaper 5.2 Major components and their functions 5.3 The table drive mechanism 5.4 Working of tool and tool support 5.5 Clamping of work through sketch. 6.0 Milling Machine 6.1 Types of milling machine and operations performed by them and also same for CNC milling machine 6.2 Explain work holding attachment 6.3 Construction & working of simple dividing head, universal dividing head 6.4 Procedure of simple and compound indexing 6.5 Illustration of different indexing methods 7.0 Slotter 7.1 Major components and their function 7.2 Construction and working of slotter machine 7.3 Tools used in slotter 8.0 Grinding 8.1 Significance of grinding operations 8.2 Manufacturing of grinding wheels 8.3 Criteria for selecting of grinding wheels 8.4 Specification of grinding wheels with example Working of Cylindrical Grinder • Surface Grinder • Centreless Grinder • 7 9.0 Internal Machining operations Classification of drilling machines 9.1 Working of Bench drilling machine • Pillar drilling machine • Radial drilling machine • 9.2 Boring Basic Principle of Boring • Different between Boring and drilling • 9.3 Broaching Types of Broaching (pull type, push type) • Advantages of Broaching and applications • 10 Surface finish, lapping 10.1 Definition of Surface finish 10.2 Description of lapping & explain their specific cutting.

CHAPTER 1

TOOL MATERIALS

The cutting tools are required to operate under high loads at elevated temperature well above 1000°C. In addition, severe frictional conditions occur between the tool and chip and between the tool and the newly machined workpiece surface.

The following factors influence the performance of cutting tools:

1. Relative hardness of the tool and work material.
2. Chemical compatibility of the tool and work material
3. Cutting temperatures.
4. Type of machining operation, i.e., continuous or intermittent
5. Rigidity and condition of machine tool. 6. Condition of the surface of workpiece, i.e., presence of scale, rust, abrasive particles.

The main requirements for cutting tool materials are

1. Wear resistance.
2. Hot hardness.
3. Toughness.
4. Cost and easy of fabrication

All the above properties are not present simultaneously in a material. For example, a material with high wear resistance and high-temperature resistance has low toughness. The selection of tool material is generally a compromise between separate requirements and their relative importance depends on the specific applications.

DESIRABLE PROPERTIES OF TOOL MATERIALS

1. Wear Resistance

Wear resistance of a tool material is its ability to retain its shape and sharpness for a sufficiently long time. This property should be retained during machining a given workpiece at a given cutting speed. Wear of tool is caused by the following mechanisms:

- (i) Abrasion: When a chip flows over the rake face of the cutting tool under high pressure, abrasion of material takes place. Abrasion is also caused by the rubbing action of the newly machined surface with the tool flank. The rate of abrasion depends upon the hardness of work material and cutting temperature.
- (ii) Adhesion: When the tool material adheres with the chip or newly machined surface, there is gradual loss of tool material. This is called wear of tool due to adhesion.
- (iii) Diffusion: The atoms of hard alloy constituents of tool material may transfer into chip or work material. This diffusion of tool material results in its weakening. The weakened layer of tool material is removed by abrasive surface.

2. Hot Hardness

The tool material must remain harder than work material at elevated operating temperatures. Hot hardness is the ability of tool material to retain its hardness even at elevated temperatures. It is desirable to develop tool material with high hot hardness. These materials can operate at higher cutting speeds resulting in high productivity.

A tool should also fully recover its hardness at room temperature after machining at high temperature. This is called recovery hardness.

3. Toughness

The tool material should be tough with high strength and ductility. It should be able to withstand shocks and vibration due to impact loads and intermittent cutting operations. There should be no breakage of tool. However, it has been found out that materials having high hot hardness and wear resistance are brittle with less toughness.

4. Cost and Ease of Fabrication

The cost and ease of fabrication should be within reasonable limits. It should be possible to regrind, weld/braze/fix to tool holder easily.

5. Thermo-physical Properties

The tool material should possess high thermal conductivity to remove heat quickly from the cutting region. It should have low coefficient of thermal expansion. It should not distort during heat treatment.

TYPES OF TOOL MATERIALS

Last century has seen many developments in the field of tool materials with increasing wear resistance, hot hardness and toughness properties to meet the demands of high-speed machining and hard machining:

1. **Carbon Steels:** The earliest tool materials used were hardened carbon steels. These steels are restricted to low cutting speeds and temperatures. The hardness of carbon steel depends upon the martensite present which softens at 250°C and above. Carbon steel tools are presently used in wood working and machining of soft materials.
2. **High-Speed Steels:** The heat treatment process was discovered and used for producing high-speed steel-cutting tools. These steels had high wear resistance and higher metal removal rates were possible by the adoption of higher cutting speeds.
3. **New Tool Materials:** Developments in metallurgical science and technology have helped to produce new tool materials such as cast alloys, cemented carbide, sintered oxides or ceramics. At the present time more than 50% of cutting tools (mostly multipoint) used world over are based on cemented carbide materials, with 40% (mostly single-point) being made from high-speed steels and the remaining 10% from all of the other material classes. In terms of the per cent of material removed, cemented carbides represent 2 to 3 times the amount removed by high-speed steels.
4. **Tool Coatings:** Recent developments in tool materials have included the coating of high-speed steel and tungsten carbide tools with thin, highwear resistant layers to improve performance.

STUDY OF VARIOUS CUTTING TOOL MATERIALS

The main characteristics of tool materials are discussed below:

1. High Carbon Steel

The main characteristics of high carbon tool steels are:

- (i) These are plain carbon steels containing 0.6 to 1.5% carbon.
- (ii) The refinement of grain size and increase in hardness is achieved with the addition of small percentage of silicon, manganese, chromium and vanadium.
- (iii) These are easy to manufacture and cutting edge can be easily sharpened.

(iv) These steels can be used with operating temperature very low. They lose hardness rapidly at temperatures greater than 200°C.

(v) They have low wear resistance and hot hardness. '

(vi) They are used in making cutters, twist drills, turning and form tools for machining soft or free cutting materials like wood, magnesium, brass and aluminium.

(vii) They are also widely used for manufacture of hard tools like taps, files, reamers, chisels, hacksaw blades, etc.

(viii) Properties can be considerably enhanced by alloying with chromium.

2. High-Speed Steel (HSS)

(i) High-speed steels are alloy carbon steels with tungsten (~ 18%) and chromium (~ 4%). Other alloying elements are cobalt, vanadium or molybdenum.

(ii) There are more than 20 grades of HSS tool materials in common use with their own advantages and limitations.

(iii) These can be divided into three main groups: tungsten based, molybdenum based and molybdenum-cobalt based alloys. The composition of some of standard grades of HSS are given in Table.

(iv) Addition of vanadium increases abrasion resistance and cobalt increases hot hardness.

(v) HSS are manufactured by conventional alloy steel manufacturing process, powder metallurgy process and electro-slag refining process.

(vi) Properties of HSS tools are significantly influenced by heat treatment process which must be carried out very carefully. During the heat treatment process, carbides of alloying elements are formed and dispersed throughout the material as very hard particles. Cobalt, however, dissolves to substitute for iron atoms in the crystal matrix.

(vii) High-speed steel-cutting tools are relatively inexpensive and tough but have limited hot hardness. These can be used for cutting temperatures upto 550°C.

(viii) HSS can be hot rolled, forged to rough shapes, then machined, heat treated and then finish ground.

(ix) It is a widely used material for manufacture of monolithic tools such as drills, taps, milling cutters, etc., for machining of steels of upto 350 BHN hardness. There is, however, an increasing tendency to use HSS inserts for turning. The inserts are clamped, brazed or welded to a carbon or low-alloy steel body. The carbon steel shanks are friction welded to HSS cutting ends of drills and narrow HSS strips are electron-beam welded to low-alloy steel bands for making band saws. Indexable HSS inserts are mechanically clamped in tool holders.

(x) HSS cutting tools are available with a thin coating of titanium nitride to increase wear resistance.

Composition and Properties of Standard High-Speed Steels

Grade	Composition (%)						Property rating 1 to 10 (highest)			
	C	W	Mo	Cr	V	Co	Wear resist- ance	tough- ness	Hard- ness	Cost
1. Conventional Steels										
T ₁	0.75	18.00	—	4.00	1.00	—	4	8	5	5
M ₁	0.80	1.75	8.50	3.75	1.15	—	4	10	5	3
M ₂	0.85	6.00	5.00	4.00	2.00	—	5	10	5	3
2. Cobalt Steels										
M ₃₃	0.88	1.75	9.50	3.75	1.15	8.25	5	5	8	5
T ₅	0.80	18.00	—	4.25	2.00	8.00	5	4	8	6
T ₆	0.80	20.00	—	4.50	1.75	12.00	5	2	9	8
3. High Vanadium Steels										
M ₃	1.05	6.00	5.00	4.00	2.40	—	6	6	6	4
M ₄	1.30	5.50	4.50	4.00	4.00	—	9	6	6	4
T ₁₅	1.50	12.00	—	4.50	5.00	5.00	10	9	9	6
4. High Hardness Cobalt Steels										
M ₄₂	1.10	1.50	9.50	3.75	1.15	8.25	6	9	9	5
M ₄₄	1.50	5.25	6.50	4.25	2.00	12.00	6	3	10	6

3. Coated High-Speed Steel Tools

This is a recent development. The high-speed steel provides a relatively ductile, shock resistant core of the tool while the coating is applied to the core which has very high wear resistance and low friction.

- (i) Thin layer (2 to 6 μm) coating of a refractory metal carbide or nitride is applied. The main coating materials used is titanium carbide, titanium nitride, hafnium nitride and alumina.
- (ii) A thin (1 to 2 μm) coating of titanium nitride (TiN) has an equivalent hardness of Rockwell C80-85. This coating has exceptional wear resistance and lower friction than the uncoated high-speed steel.

(iii) There are two methods of coating used:

Physical Vapour Deposition (PVD). Particles of the coating are deposited physically onto the surface of workpiece kept in high vacuum condition at temperatures in the range of 200-500°C.

Chemical Vapour Deposition (CVD). The tools are heated in a sealed reaction chamber to around 1000°C in an inert atmosphere. Gaseous hydrogen and volatile compounds supply the metallic and non-metallic constituents. It is a thermochemical process and is a more commonly used method.

- (iv) The cost of coated tool is 2 to 5 time the cost of plain HSS tool.
- (v) The life of a coated tool is increased by 5 to 10 times the life of plain HSS tool.
- (vi) Coated HSS tools are used for cutting not only general materials but also hard-to-machine alloys of Cr-Mo steel. Hard machining can replace grinding for the manufacture of complex shapes on one machine tool and using single tool.

4. Cast Alloys

- (i) Cast alloy tools are cast into their final shape.
- (ii) These alloys do not contain iron and contain primarily cobalt (40 - 55%): chromium (25 -35%), tungsten (1.5 - 3%) and carbon (0 - 5%).
- (iii) The carbide phase is about 25 to 30% by volume of the matrix.
- (iv) The tools are cast in graphite chilled molds to produce a fine grained hard surface made up of complex carbides.
- (v) The core of the tool is a tough carbide enriched material.
- (vi) These tools can be used at higher speeds than HSS tools. These alloys retain hardness upto temperatures of 750°C.
- (vii) These materials have low coefficient of friction and do not form built-up edge during machining.
- (viii) These are used for machining of cast iron, malleable iron and hard bronzes.
- (ix) These are useful for making form tools as they are castable.

5. Cemented Carbide Tools

These are the most commonly used cutting tools at present:

- (i) A mixture of 94% tungsten powder and 6% carbon by weight is prepared. This mixture is combined with cobalt, compacted and sintered in a furnace at 1400°C. The cobalt acts as binder phase. The percentage of hard carbide particles varies from 60 to 95%. This process of mixing and sintering or cementing is called powder metallurgy and the product is called sintered or cemented.

- (ii) Different manufacturers use different proportions of tungsten carbide (WC) cobalt (Co) and other alloying elements and also different particle size mixing procedures and sintering temperatures and pressures to produce tools of the same classification.
- (iii) The properties of carbide tools are highly dependent on cobalt content, Hardness of tool material decreases and toughness increases with the increase of cobalt.
- (iv) The hardness of cemented carbide also depends on grain size. The finer the grain size, greater the hardness.
- (v) The cemented carbides can maintain high hardness values at temperatures as high as 1200°C. These can be used at much higher cutting speeds than HSS or cast-alloy tool materials.
- (vi) Cemented carbides are not tough and cannot be shaped after sintering, therefore, these are used in the form of small tips or inserts which are brazed or clamped to steel shanks. The clamped-on inserts are thrown away after all the cutting edges have been worn. These are called disposable or throwaway inserts.
- (vii) Straight tungsten carbides are the strongest and most wear resistant but are subject to rapid cratering when machining steels. Tantalum carbide and titanium carbide are added to improve resistance to cratering.
- (viii) New grades of cemented carbide with increased densities and smaller grain size powder have been developed.
- (ix) Research is taking place into “nano-phase” carbides with particle size of the order of 0.1 - 0.2 μm .
- (x) Coating of aluminium and zirconium oxides deposited on tool surface at high temperature retard diffusion wear of the tool. A very thin coating of titanium carbide or hafnium nitride can improve the resistance to crater wear of tungsten carbide tools.

Table Standard Classification of Cemented Carbide Tool Materials

ISO Designation	Work Material	Composition % age				Machining applications
		WC	Co	TiC	TaC	
P01	Steel	64	3	25	8	Finishing
P10	Steel	76	6	12	6	Finishing
P20	Steel					Roughing
P30	Steel	82	8	8	2	Roughing
P40	Steel	70	12	6	12	Interrupted Cuts
P50	Steel					Interrupted Cuts
M10	Steels, cast irons, non-ferrous metals					Finishing
M20	Steels, cast irons, non-ferrous metals					Finishing
M30	Steels, cast irons, non-ferrous metals					Finishing
M40	Steels, cast irons non-ferrous metals					Finishing
K01	Cast Irons	97	3	–	–	Finishing
K10	Non-ferrous metals	96	4	–	–	Finishing
K20	Non-metallic	94	6	–	–	Finishing
K40	Non-metallic	94	6	–	–	Roughing

Applications: P series for long chipped metal and steels.
M series for stainless steels and heat resistant alloys.
K series for short chipping materials, cast irons, steels and non-ferrous alloys.

6. Cermet Tools

- (i) These are cemented materials that use hard particles other than tungsten carbide. Hard particles include titanium carbide, titanium nitride, titanium carbonitride and molybdenum carbide.
- (ii) The metal binder phase is a mixture of cobalt and nickel.
- (iii) These are produced by powder metallurgy as similar to that for tungsten Carbide.
- (iv) These are more wear resistant and are of same hardness as tungsten Carbide.
- (v) Strength, toughness and thermal shock resistance are lower.
- (vi) These can handle high cutting speeds with moderate feeds.
- (vii) These are used for semi-finish and finish milling.

7. Ceramic Tools

- (i) Ceramic tools are very hard with high compressive strength and low thermal conductivity.
- (ii) They are extremely brittle and cannot be used where shock and vibration occur.

- (iii) These are made from sintered aluminium oxide (Al_2O_3), SiAlON (a combination of silica, aluminium, oxygen and nitrogen) and silicon nitride.
- (iv) Various powders are mixed together and sintered at about 1700°C .
- (v) Sintered oxides can be used at cutting speeds two to three times those employed with tungsten carbides.
- (vi) Aluminium oxide is the most common ceramic tool and performs best for finishing and semi-finishing with non-interrupted cuts.
- (vii) Ceramic cutting tools are used for turning and milling of cast iron, superalloys and finishing of hardened steels.
- (viii) Composite ceramic tools consisting of Al_2O_3 matrix reinforced by tiny silicon carbide whiskers are used for roughing and finishing of nickel based alloys, cast iron and steels. These tools have very high fracture toughness.
- (ix) They are mostly available in the form of throwaway inserts.

8. Diamond

- (i) The single crystal natural or synthetic diamond is used as cutting tool material.
- (ii) Diamond has both hard and soft axes. If it is used in the direction of a soft axis it wears off quickly.
- (iii) Diamond has hardness more than any other material. It is chemically inert and has high thermal conductivity. Oxidation of diamond starts at about 450°C and can crack. Therefore, diamond tool is kept flooded with coolant during cutting and light feeds are used.
- (iv) The diamond is extremely brittle. There should be minimum vibrations during cutting operation. The machine tool, tool holder and clamping of diamond tool to the tool shanks must be rigid.
- (v) These are used for machining of non-ferrous metals like aluminium, brass, copper and bronze. It is also used for non-metallic materials like plastics, epoxy resins, hard rubber, glass and precious metals like gold, silver and platinum. These should not be used for machining ferrous metals.
- (vi) Diamonds can be used for high cutting speeds. The feed should be limited to 0.02 to 0.1 mm/sec and depths of cut to about 0.5 mm.

9. Abrasives. The abrasive grains are used in grinding wheels, abrasive belts, sand papers, sand blasting and other similar operations. These operations actually involve cutting in which the abrasive grains produce tiny chips from the work material.

The abrasive commonly used may either be natural or artificial (manufactured). Natural abrasives include corundum, emery, quartz, garnet and diamond. Manufactured abrasives include aluminium oxide, silicon carbide and boron carbide.

Aluminium oxide and silicon carbide are by far the most widely used for all grinding abrasives. Silicon carbide is harder than aluminium oxide but is, in general more friable. Hardness is of importance chiefly in the grinding of very hard materials. The choice between silicon carbide and Aluminium oxide lies in balancing the attrition resistance with the body strength which determines the ability to fracture when dulled.

SOME RECENT DEVELOPMENTS:

1. UCON. It is a nitrided refractory metal alloy having composition of 50% columbium, 30% titanium and 20% tungsten with no carbide. It has excellent thermal shock resistance, high hardness, and toughness. It exhibits excellent resistance to diffusion and chip welding. It is available in the form of throwaway inserts having 3-5 times more edge life than conventional carbides. It operates in the speed range of 250-500 m/min on steels of 200 BHN.
2. CBN (Cubic Boron Nitride). It consists of atoms of nitrogen and boron, with a special structural configuration similar to diamond. It has high hardness and high thermal conductivity. It is chemically inert. It is used as a grinding wheel for HSS tools and stellites. These are available in the form of indexable insert and are capable of machining hardened tool steel, chilled cast iron, high strength alloys. It is hardest material next to diamond.
3. Sialon. The word Si Al ON stands for silicon nitride-based materials with aluminium and oxygen additions. It is produced by milling Si_3N_4 , aluminium nitride, alumina and yttria. The mixture is dried, pressed to shape and sintered at 1800°C . This tool material is tougher than alumina and thus suited for interrupted cuts. Aerospace alloys and nickel-based gas turbine discs can be machined using sialon tool bit at a cutting speed of 200-300 m/mt.
4. Polycrystalline Diamond (PCD). High speed machining operations make use of PCD and CBN tools for best results. In motor vehicle and aircraft manufacturing industries, component parts of non-metallic materials are being used extensively. PCD cutters achieve exceptional standards of surface quality at high feed and material removal rates with such materials. PCD tools are extensively used for machining aluminium components.

CHAPTER 2

CUTTING TOOLS

CLASSIFICATION OF CUTTING TOOLS

All the cutting tools used in metal cutting can be broadly classified as :

1. Single point Tools, i.e., those having only One cutting edge ; such as Lathe tools, Shaper tools, Planer tools, Boring tools, etc.
2. Multi-point Tools, i.e., those having more than one cutting edges ; such as Milling cutters, Drills, Broaches, Grinding wheels, etc. These tools may, for the sake of analysis, be considered as consisting of a number of Single point tools, each forming a cutting edge.

The Cutting tools can also be classified according to the motion as :

- > Linear motion tools ; Lathe, Boring, Broaching, Planing, Shaping tools, etc.
- > Rotary motion tools ; Milling cutters, Grinding wheels, etc.
- > Linear and Rotary tools ; Drills, Honing tools, Boring Heads, etc.

IMPORTANT TERMS

Before proceeding further, it would be advisable to be acquainted with a few important terms related to the Geometry of Single point tools.

1. **Shank.** It forms the main body of a solid tool and it is this part of the tool which is gripped in the Tool Holder.
2. **Face.** It is the top surface of the tool between the shank and the point of the tool. In the cutting action, the chips flow along this surface only.
3. **Point.** It is the wedge shaped portion where the face and flank of the tool meet. It is the cutting part of the tool. It is also called nose, particularly in case of Round nose tools.
4. **Flank.** Portion of the tool which faces the work is termed as flank. It is the surface adjacent to and below the cutting edge when the tool lies in a horizontal position.
5. **Base.** It is actually the bearing surface of the tool on which it is held in a Tool holder or clamped directly in a Tool post.

6. Heel. It is the curved portion at the bottom of the tool where the base and flank of the tool meet, as shown in Fig.

7. Nose radius. If the Cutting tip (nose) of a single point tool carries a sharp cutting point, the cutting tip is weak. It is, therefore, highly stressed during the operation, may fail or lose its cutting ability soon and produce marks on the machined surface.

In order to prevent these harmful effects the nose is provided with a radius, called Nose radius. It enables greater strength of the Cutting tip, a prolonged Tool life and a superior Surface finish on the workpiece.

Also, as the value of this radius increases, a higher cutting speed can be used. But, if it is too large it may lead to Chatter. So, a balance has to be maintained. Its value normally varies from 0.4 mm to 1.6 mm, depending upon several factors like depth of cut, amount of feed, type of cutting, type of tool (solid or with insert), etc.

PRINCIPAL ANGLES OF SINGLE POINT TOOLS

The different Angles provided on Single point Tools play a significant role in successful and efficient machining of different metals. A thorough study of these tool angles is, therefore, a must. The main angles provided on these tools are shown in Figure.

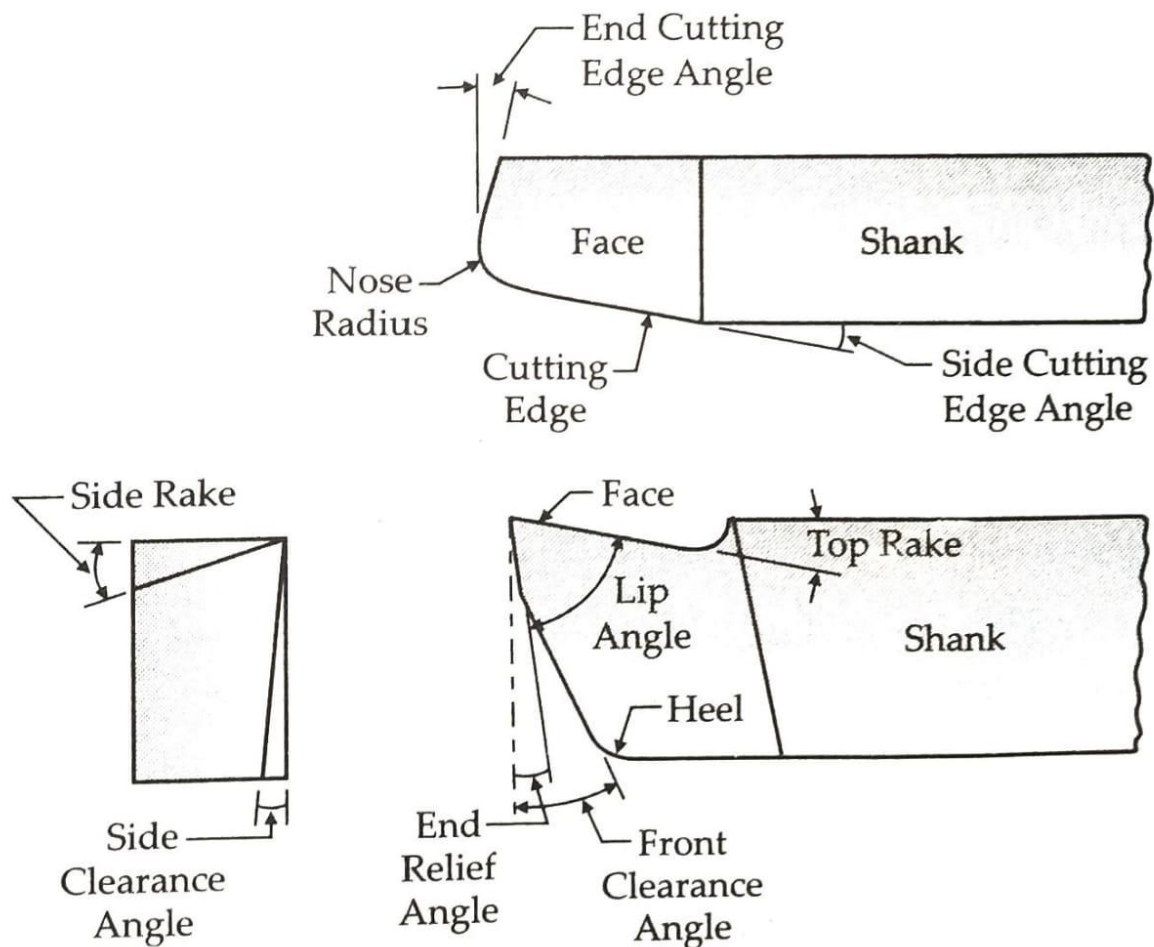

1. Rake angle.

It is the angle formed between the face of the tool and a plane parallel to its base. If this inclination is towards the shank, it is known as Back Rake or Top Rake. When it is measured towards the side of the tool, it is called the Side rake.

These rake angles guide the chips away from the cutting edge, thereby reducing the chip pressure on the face and increasing the keenness of the tool so that less power is required for cutting.

It is important to note that an increased Rake angle will reduce the strength of the cutting edge. With the result, the Tools used for cutting hard metals are given Smaller Rake Angles whereas those used for softer metals contain Larger Rakes.

Negative Rake. The rake angles described above are called Positive Rake Angles. When no rake is provided on the tool, it is said to have a **zero rake**. When the face of the tool is so ground that it slopes upwards from the point it is said to contain a Negative Rake.

It, obviously, reduces the keenness of the tool and increases strength of the cutting edge. Such a rake is usually employed on Carbide Tipped Tools when they are used for machining Extra-hard surfaces, Hardened steel parts and for taking Intermittent cuts.

A tool with Negative rake will have a larger Lip angle, resulting in a stronger tool. The value of Negative Rake on these tools normally varies from 5° to 10° .

2. Lip Angle. The angle between the face and the flank of the tool is known as Lip angle. It is also sometimes called the **Angle of Keeness** of the tool. Strength of the cutting edge or point of the tool is directly affected by this angle. Larger the lip angle stronger will be the cutting edge and vice versa.

3. Clearance Angle. It is the angle formed by the front or side surfaces of the tool which are adjacent and below the cutting edge when the tool is held in a horizontal position. It is the angle between one of these surfaces and a plane normal to the base of the tool.

When the surface considered for this purpose is in front of the tool, i.e., just below the point, the angle formed is called Front Clearance and when the surface below the side cutting edge is considered the angle formed is known as Side Clearance angle.

The purpose of providing Front clearance is to allow the tool to cut freely without rubbing against the surface of the job, and that of the Side clearance to direct the cutting thrust to the metal area adjacent to the cutting edge.

4. Relief Angle. It is the angle formed between the flank of the tool and a perpendicular line drawn from the cutting point to the base of the tool.

Side relief angle: It is the angle between the portion of the side flank immediately below the side cutting edge and a line perpendicular to the base of the tool, and measured at right angle to the side flank.

End relief angle: It is the angle between the portion of the end flank immediately below the end cutting edge and a line perpendicular to the base of the tool, and measured at right angle to the end flank.

These angles are provided so that the flank of the tool clears the workpiece surface and there is no rubbing action between the two.

These angles range from 5° to 15° for general turning.

Small relief angles are necessary to give strength to the cutting edge when machining hard and strong materials.

Tools with increased values of relief angles penetrate and cut the workpiece material more efficiently and this reduces the cutting forces.

5. Side cutting edge angle: it is the angle between the side cutting edge and the side of the tool shank. It is also known as lead angle.

This angle prevents interference as the tool enters the work material.

For general machining work this angle is kept between 15° to 30° .

6. End cutting edge angle: this is the angle between the end cutting edge and a line normal to the tool shank.

This angle provides a clearance or relief to the trailing end of the cutting edge to prevent rubbing or drag between the machined surface and the trailing part of the cutting edge.

An angle of 8° to 15° has been found satisfactory for this purpose.

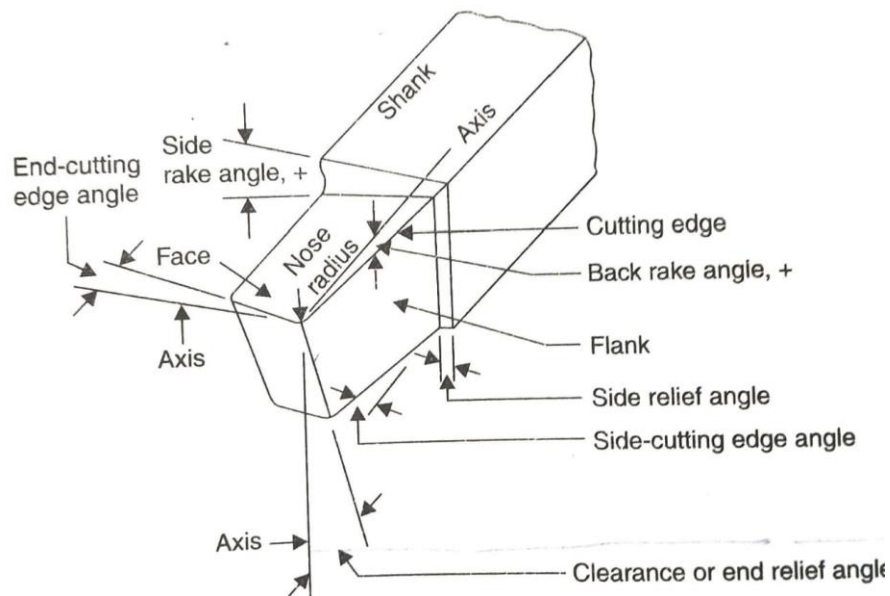

Tool signature:

- I. Back rack angle
- II. Side rake angle
- III. End relief angle
- IV. Side relief angle
- V. End cutting edge angle
- VI. Side cutting edge angle
- VII. Nose radius

A typical tool signature:

0-10-6-6-8-90-1mm

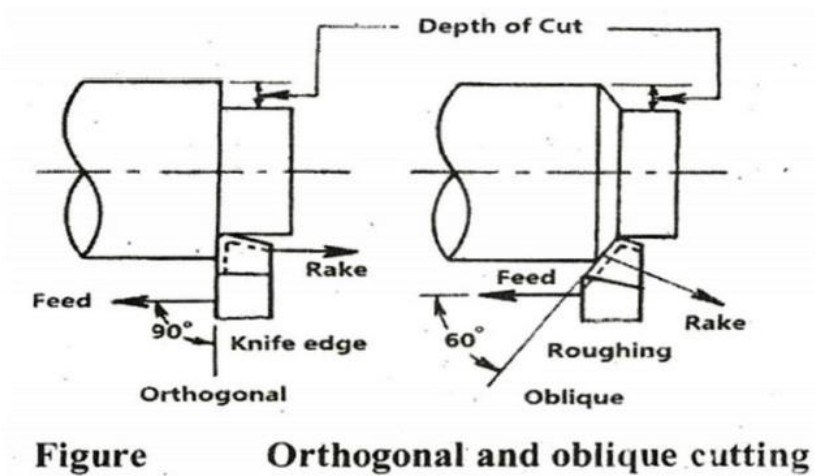

CUTTING SPEED, FEED AND DEPTH OF CUT (LATHE WORK)

1. **Cutting speed:** The cutting speed (in a lathe for turning operation) is the peripheral speed of the workpiece past the cutting tool.

Mathematically, $V = \pi DN / 1000$ m/min

Where, V = Cutting/peripheral speed, m/min,

D = Diameter of the job, mm, and

N = Job or spindle speed, r.p.m.

The main factors which influence the selection of a proper cutting speed are :

- Material of the cutting tool.
- Hardness and machinability of the metal to be machined.
- Quality of heat treatment, if it is a H.S.S. steel tool.
- Whether machining is to be done with or without the use of a coolant.
- Rigidity of the tool and the work.
- Tool shape.
- Depth of cut.
- Feed to be given to the tool.
- Rigidity of the machine.

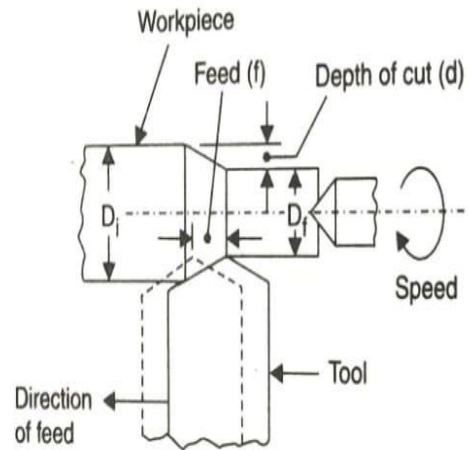

Fig. 9.31. Concept of cutting speed, feed and depth of cut.

2. Feed (f):

Feed may be defined as the distance that a tool advances into the work during one revolution of the headstock spindle.

- Feed is expressed in mm/revolution.
- The smaller the feed, the better the finish although a great deal depends on the type of lathe tool used, and a well sharpened tool is necessary.
- Larger feeds reduce machining time, but the tool life is reduced.

Feed may be calculated as follows:

$$f = L/N \cdot T_m \text{ mm/rev}$$

Where, L = Length of cut, mm,

N = r.p.m, and

T_m = Machining/cutting time, min.

3. Depth of cut (d):

The depth of cut 'd' is the perpendicular distance measured from the machined surface to the uncut (or previous cut) surface of the workpiece. For turning operations, the depth of cut is expressed as:

$$d = \frac{D_i - D_f}{2}$$

Where, D_i = Initial/original diameter of the workpiece, mm, and

D_f = Final diameter of the workpiece, mm.

For rough cutting, the depth of cut should be as large as possible, consistent with the size or capacity of the centre lathe and the material being turned.

The values of speed, feed and depth of cut, in general, depend upon the following factors

- Type of workpiece material
- Type of tool material
- Type of surface finish required

COOLANTS AND LUBRICANTS

The metal working fluid (coolants and lubricants) usually performs the following functions:

1. Increases the tool life and produces better finish by carrying away the heat generated during metal working. It cools the tool and workpiece.
2. Provide adequate lubrication between the tool and workpiece and the tool and the chips. Minimizes the friction between mating surfaces and, thus, prevents rise in temperature.
3. Prevents the adhesion of chips to the tool or workpiece or both. It protects the finished surface from corrosion.
4. Provides a cushioning effect between the job surface and the tool to prevent adhesion of the two, such as in stamping, extrusion etc.
5. Drives away the chips, scale and dirt from cutting zone.

CHARACTERISTICS OF A GOOD CUTTING FLUID:

- a) It should provide sufficient lubrication between the tool and work and the tool and chips so as to minimize tool wear and reduce power consumption.
- b) It must carry away the heat generated during the process and, thus, cool the tool and workpiece both in order to minimize the tool wear and prevent distortion of the workpiece.
- c) Its flash point should be amply high.
- d) It should be able to impart anti welding properties to the tool and the workpiece, otherwise very poor finish may result.
- e) It should not discolour the finished work surface.
- f) It should be non-poisonous and should not cause skin irritation.

- g) It should carry such constituents which will prevent the finished work surface and the tool from being rusted or corroded.
- h) It should not produce fog and smoke during use

Types of cutting fluids:

The cutting fluids are classified as follows:

1. Cutting oils:
 - a. Active cutting oils.
 - b. Inactive cutting oils. These are straight mineral oils or straight mineral oils mixed with fatty oils, acids or sulphurised fatty oils.

By activeness or inactiveness of the cutting oils we mean as to whether a particular cutting oil contains such constituents or not that can react chemically with work surface to help the machining operation.

2. Water soluble oils or compounds.

CUTTING FLUIDS USED IN DIFFERENT OPERATIONS:

Operations	Suggested fluids
1. Turning	Emulsions or straight oils.
2. Tapping and threading	Active type mineral fatty oil.
3. Drilling and boring	Soluble oils.
4. Reaming	Soluble oils.
5. Planing and shaping	Usually no cutting oil is used.
6. Milling	Sulphurised mineral fatty oils or emulsions
7. Broaching	Heavy, active type cutting oils
8. Thread rolling	Straight mineral oil or emulsions.

Types of lubricants :

The various types of metal working lubricants are:

1. Mineral oils: These lubricants do not find much favour in boundary lubrication, as in deep draw and extrusion processes. If at all they are to be used in such processes they are used in compounded form.

2. Fatty oils and acids: These are extensively used for boundary lubrication. Fatty oils are used in heat-treatment process as a quenching medium for obtaining a high degree of hardness. Fatty acid is used as a flux in tinning work.
3. Waxes: Waxes (derived from petroleum) are used in various processes like rolling, drawing, extrusion, tinning and wet coating on mould surfaces.
4. Graphite suspensions: These lubricants are widely used in foundry and forging work.
5. Compounded emulsions: The compounded emulsions are best suited for use in heavy duty operations. The water usually varies from 5 to 15 parts.
6. Conventional emulsions: These emulsions are prepared by mixing the neat soluble oils in water. The main constituents of these emulsions are soap, fat, fatty acids and water. Most of the cutting and grinding work done in the workshops involves the use of such emulsions.
7. Aqueous solutions: These solutions are principally used as coolants. However, some of them show reasonably good lubricating properties. Soda or borax in water is the cheapest and best solution mainly for cooling.
8. Compounded mineral oils: For drawing, cutting and forming operations the mineral oils are compounded with sulphurised fatty oils. The sulphurised mineral oils are commonly used under conditions of high pressures and excessive friction. The sulphurised mineral-fatty oils are sometimes added with suitable amount of chlorine to give chlorinated compounds, which are widely used in different metal working operations.
9. Minerals: Various types of minerals (different types of salts, metals and refractory materials) are used as metal working lubricants or coolants.

CHAPTER 3

LATHE MACHINE

Lathe is considered as one of the oldest machine tools and is widely used in industries. It is called as mother of machine tools. It is said that the first screw cutting lathe was developed by an Englishman named Henry Maudslay in the year 1797. Modern high speed, heavy duty lathes are developed based on this machine. The primary task of a lathe is to generate cylindrical workpieces. The process of machining a workpiece to the required shape and size by moving the cutting tool either parallel or perpendicular to the axis of rotation of the workpiece is known as turning. In this process, excess unwanted metal is removed. The machine tool useful in performing plain turning, taper turning, thread cutting, chamfering and knurling by adopting the above method is known as lathe.

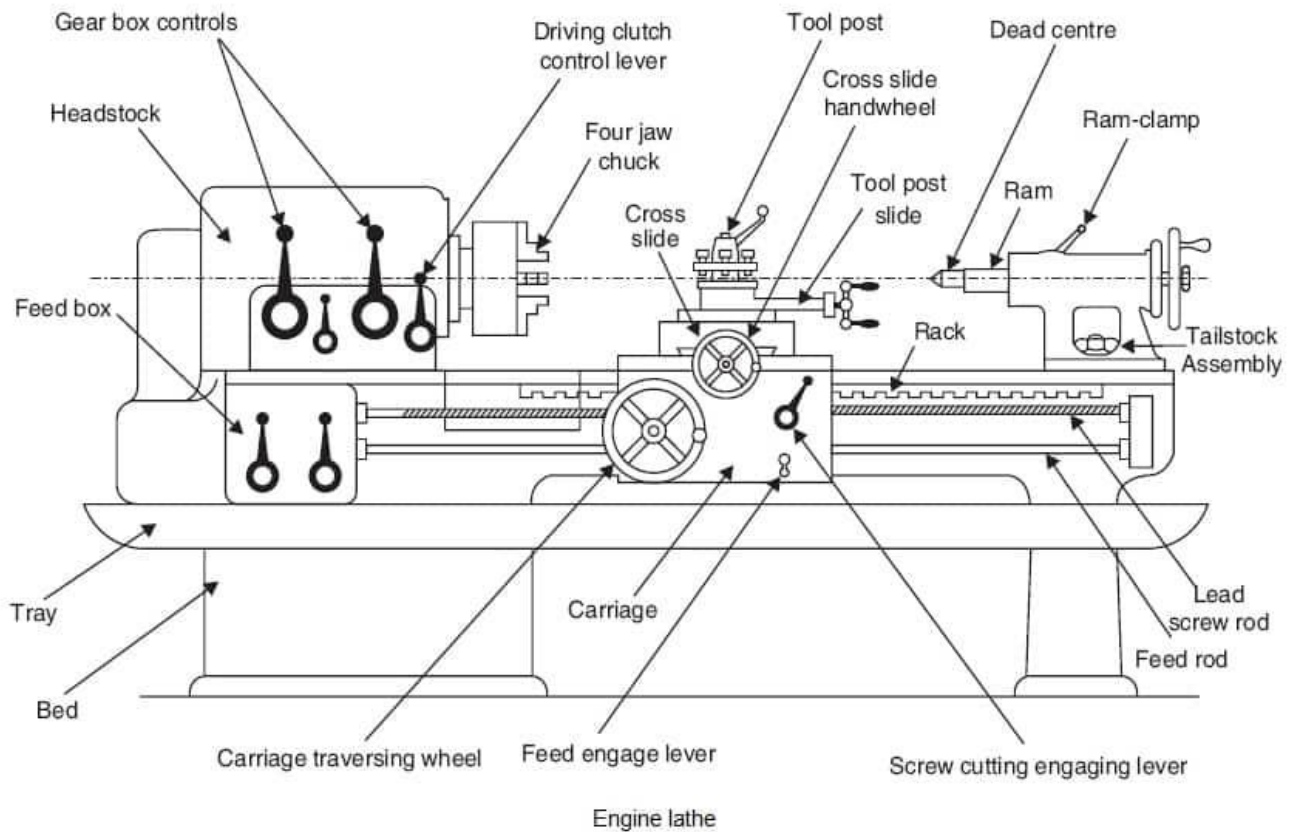

The main function of lathe machine is to remove metal from a piece of work to give it the required shape and size. The work is held securely and rigidly on the machine and then turn against the cutting tools which remove metal from the work in the forms of chips.

Main parts of a lathe

Every individual part performs an important task in a lathe. Some important parts of a lathe are

listed below:

1. Bed
2. Headstock
3. Spindle
4. Tailstock
5. Carriage
 - a. Saddle
 - b. Apron
 - c. Cross-slide
 - d. Compound rest
 - e. Compound slide
 - f. Tool post
6. Feed mechanism
7. Lead screw
8. Feed rod

Bed

Bed is mounted on the legs of the lathe which are bolted to the floor. It forms the base of the machine. It is made of cast iron and its top surface is machined accurately and precisely. Headstock of the lathe is located at the extreme left of the bed and the tailstock at the right extreme. Carriage is positioned in between the headstock and tailstock and slides on the bed guide ways.

The top of the bed has flat or 'V' shaped guide ways. The tailstock and the carriage slides on these guide ways. Inverted 'V' shaped guide ways are useful in better guide and accurate alignment of saddle and tailstock. The metal burrs re automatically fall through. Flat bed guide ways can be fo useful in heavy machines handling large workpieces. But th

Headstock

Headstock is mounted permanently on the inner guide way bed. The headstock houses a hollow spindle and the mecl multiple speeds. The headstock will have any of the follow altering the spindle speeds:

- (i) Stepped cone pulley drive
- (ii) Back gear drive
- (iii) All gear drive

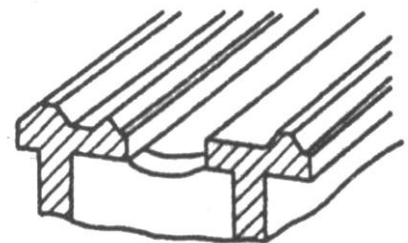

Fig 1 : Lathe bed with V shaped guideway

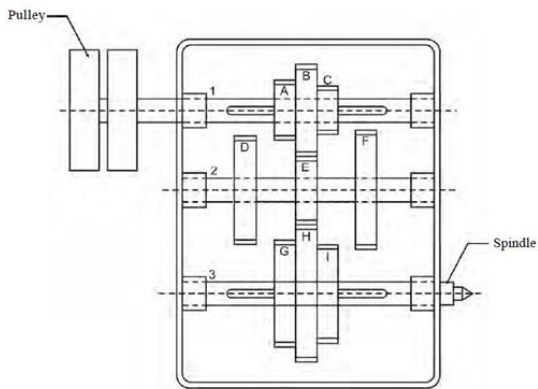

Fig 3: All gear drive

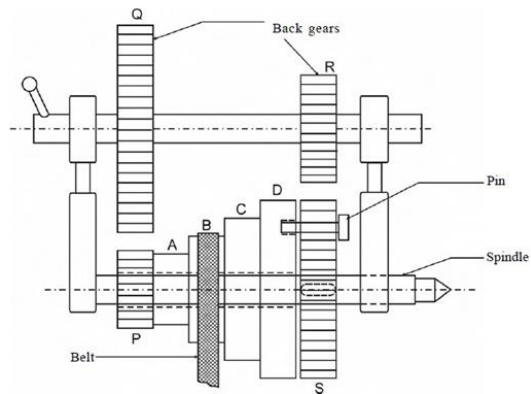

Fig 2: Stepped cone pulley with back gear

Spindle

The spindle rotates on two large bearings housed on the headstock casting. A hole extends through the spindle so that a long bar stock may be passed through the hole. The front end of the spindle is threaded on which chucks, faceplate, driving plate and catch plate are screwed. The front end of the hole is tapered to receive live centre which supports the work. On the other side of the spindle, a gear known as a spindle gear is fitted. Through this gear, tumbler gears and a main gear train, the power is transmitted to the gear on the leadscrew.

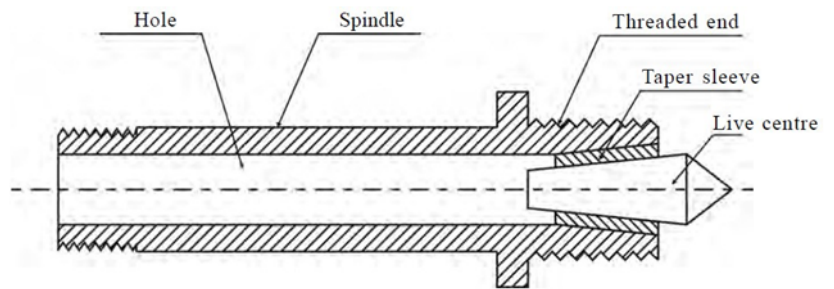

Fig 4: Head stock spindle

Tailstock

Tailstock is located on the inner guide ways at the right side of the bed opposite to the headstock. The body of the tailstock is bored and houses the tailstock spindle. The spindle moves front and back inside the hole. The spindle has a taper hole to receive the dead centre or shanks of tools like drill or reamer. If the tailstock hand wheel is rotated in the clockwise direction, the spindle advances. The spindle will be withdrawn inside the hole, if the hand wheel is rotated in anti-clockwise direction.

The main uses of tailstock are:

1. It supports the other end of the long workpiece when it is machined between centres.
2. It is useful in holding tools like drills, reamers and taps when performing drilling, reaming and tapping.

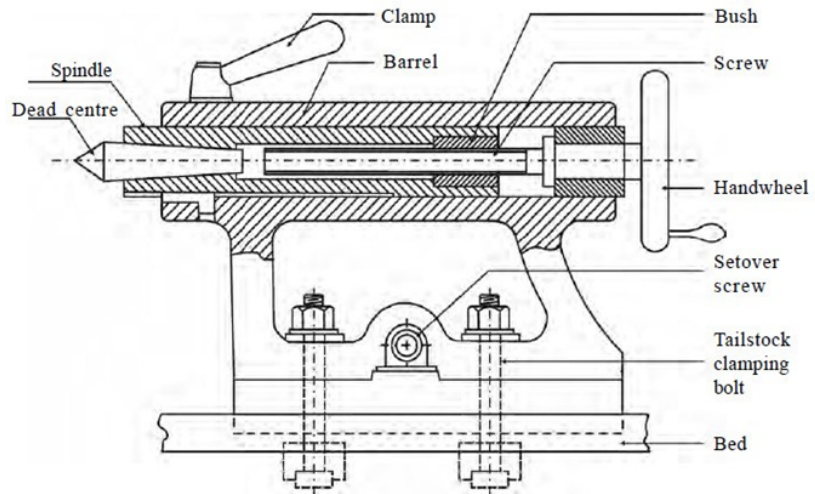

Fig 5: Tail stock

Carriage

Carriage is located between the headstock and tailstock on the lathe bed guide ways. It can be moved along the bed either towards or away from the headstock. It has several parts to support, move and control the cutting tool. The parts of the carriage are:

- a) saddle
- b) apron
- c) cross-slide
- d) compound rest
- e) compound slide
- f) tool post

Saddle:

It is an “H” shaped casting. It connects the pair of bed guide ways like a bridge. It fits over the bed and slides along the bed between headstock and tailstock. The saddle or the entire carriage can be moved by providing hand feed or automatic feed.

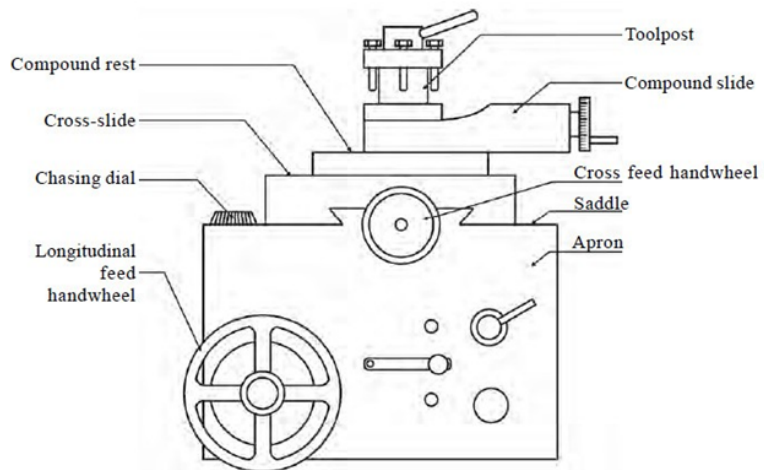

Fig 6: Carriage

Cross slide:

Cross-slide is situated on the saddle and slides on the dovetail guide ways at right angles to the bed guide ways. It carries compound rest, compound slide and tool post. Cross slide hand wheel is rotated to move it at right angles to the lathe axis. It can also be power driven. The cross slide hand wheel is graduated on its rim to enable to give known amount of feed as accurate as 0.05mm.

Compound rest:

Compound rest is a part which connects cross slide and compound slide. It is mounted on the cross-slide by tongue and groove joint. It has a circular base on which angular graduations are marked. The compound rest can be swivelled to the required angle while turning tapers. A top slide known as compound slide is attached to the compound rest by dove tail joint. The tool post is situated on the compound slide.

Tool post:

This is located on top of the compound slide. It is used to hold the tools rigidly. Tools are selected according to the type of operation and mounted on the tool post and adjusted to a convenient working position. There are different types of tool posts and they are:

1. Single way tool post
3. Four way tool post
4. Quick change tool post

Single way tool post

The tool is held by a screw in this tool post. It consists of a round bar with a slotted hole in the centre for fixing the tool by means of a setscrew. A concave ring and a convex rocker are used to set the height of the tool point at the right position. The tool fits on the flat top surface of the rocker. The tool post is not rigid enough for heavy works as only one clamping screw is used to clamp the tool.

Four way tool post

This type of tool post can accommodate four tools at a time on the four open sides of the post. The tools are held in position by separate screws and a locking bolt is located at the centre. The required tool may be set for machining by swivelling the tool post. Machining can be completed in a shorter time because the required tools are pre-set.

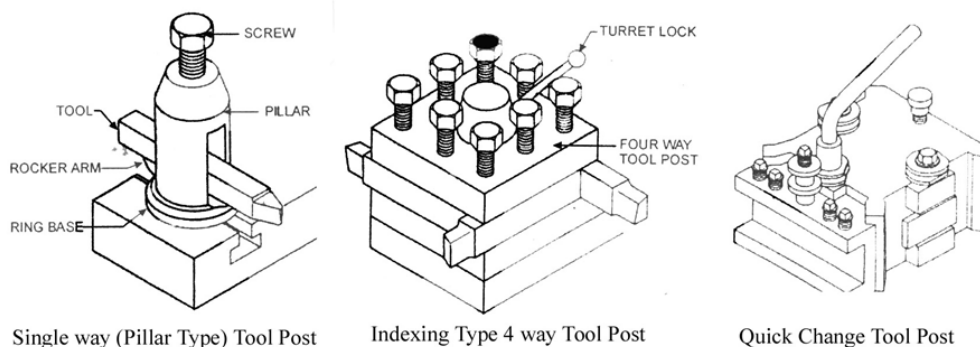

Fig 6: Types of tool posts

Lead screw

The leadscrew is a long threaded shaft used as master screw. It is brought into operation during thread cutting to move the carriage to a calculated distance. Mostly leadscrew are Acme threaded.

The leadscrew is held by two bearings on the face of the bed. A gear is attached to the lead screw and it is called as gear on leadscrew. A half nut lever is provided in the apron to engage half nuts with the leadscrew.

Feed rod

Feed rod is placed parallel to the leadscrew on the front side of the bed. It is a long shaft which has a keyway along its length. The power is transmitted from the spindle to the feed rod through tumbler gears and a gear train. It is useful in providing feed movement to the carriage except for thread cutting and to move cross-slide. A worm mounted on the feed rod enables the power feed movements.

Types of lathe

Various designs and constructions of lathe have been developed to suit different machining conditions and usage. The following are the different types of lathe:

1. Speed lathe
 - a. Woodworking lathe
 - b. Centering lathe
 - c. Polishing lathe
 - d. Metal spinning lathe
2. Engine lathe
 - a. Belt driven lathe
 - b. Individual motor driven lathe
 - c. Gear head lathe
3. Bench lathe
4. Tool room lathe
5. Semi automatic lathe
 - a. Capstan lathe
 - b. Turret lathe
6. Automatic lathe
7. Special purpose lathe
 - a. Wheel lathe
 - b. Gap bed lathe
 - c. 'T' lathe
 - d. Duplicating lathe

Size of a lathe (Specification of Lathe)

The size of a lathe is specified by the following points

1. The length of the bed
2. Maximum distance between live and dead centres.
3. The height of centres from the bed
4. The swing diameter:

The swing diameter over bed - It refers to the largest diameter of the work that will be rotated without touching the bed

The swing diameter over carriage - It is the largest diameter of the work that will revolve over the saddle.

5. The bore diameter of the spindle
6. The width of the bed
7. The type of the bed
8. Pitch value of the lead screw
9. Horse power of the motor

10. Number and range of spindle speeds
11. Number of feeds
12. Spindle nose diameter
13. Floor space required
14. The type of the machine

Work holding devices used in a lathe (accessories)

The work holding devices are used to hold and rotate the workpieces along with the spindle. Different work holding devices are used according to the shape, length, diameter and weight of the workpiece and the location of turning on the work.

They are:

- | | |
|------------------|-------------|
| 1. Chucks | 5. Carriers |
| 2. Face plate | 6. Mandrels |
| 3. Driving plate | 7. Centres |
| 4. Catch plate | 8. Rests |

Chucks

Workpieces of short length, large diameter and irregular shapes, which can not be mounted between centres, are held quickly and rigidly in chuck. There are different types of chucks namely, Three jaw universal chuck, Four jaw independent chuck, Magnetic chuck, Collet chuck and Combination chuck.

Three jaw self-Centering chuck

The three jaws fitted in the three slots may be made to slide at the same time by an equal amount by rotating any one of the three pinions by a chuck key. This type of chuck is suitable for holding and rotating regular shaped workpieces like round or hexagonal rods about the axis of the lathe. Workpieces of irregular shapes cannot be held by this chuck. The work is held quickly and easily as the three jaws move at the same time.

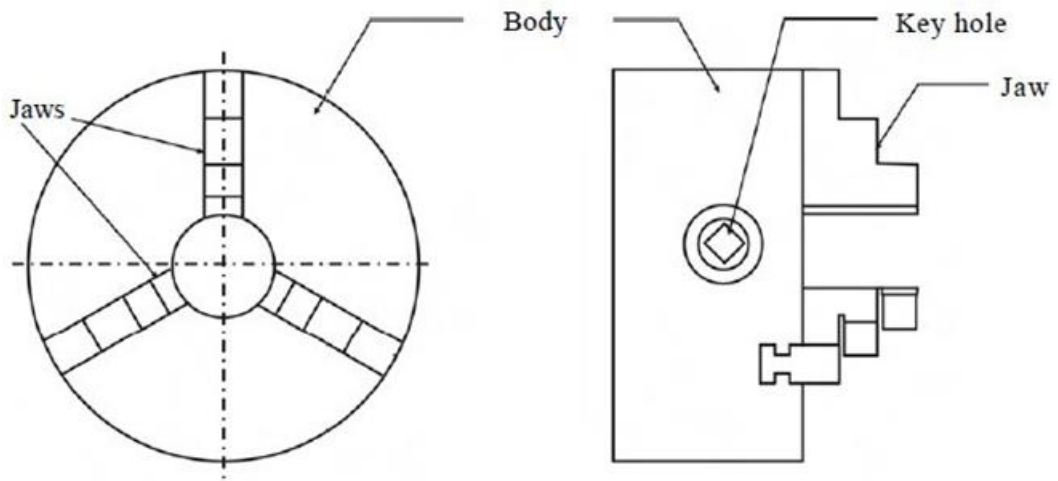

Four jaw independent chuck

There are four jaws in this chuck. Each jaw is moved independently by rotating a screw with the help of a chuck key. A particular jaw may be moved according to the shape of the work. Hence this type of chuck can hold works of irregular shapes. But it requires more time to set the work aligned with the lathe axis. Experienced turners can set the work about the axis quickly. Concentric circles are inscribed on the face of the chuck to enable quick Centering of the workpiece.

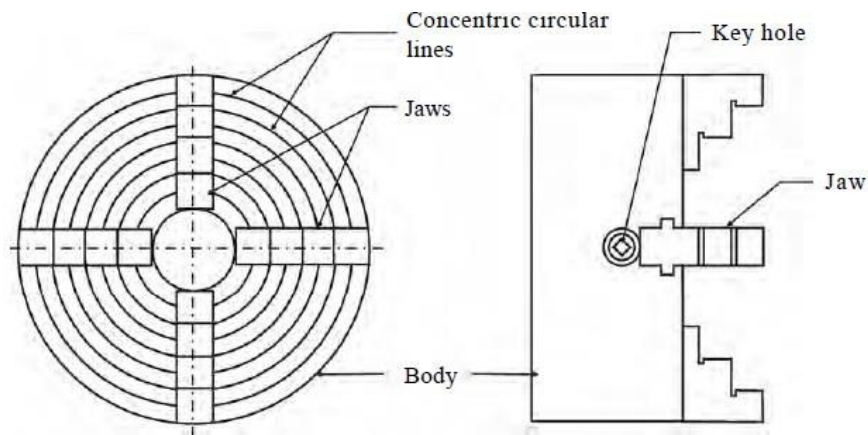

Magnetic chuck

The holding power of this chuck is obtained by the magnetic flux radiating from the electromagnet placed inside the chuck. Magnets are adjusted inside the chuck to hold or release the work. Workpieces made of magnetic material only are held in this chuck. Very small, thin and light works which cannot be held in an ordinary chuck are held in this chuck.

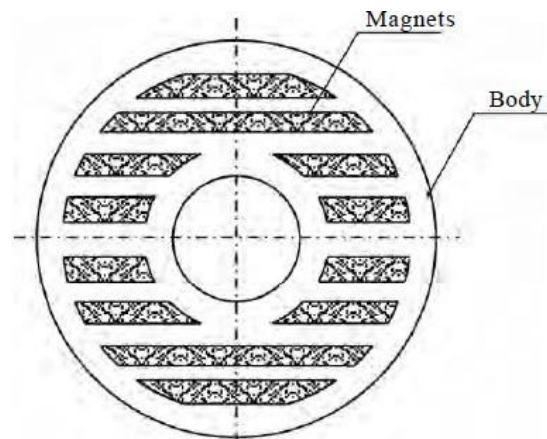

Collet chuck

Collet chuck has a cylindrical bushing known as collet. It is made of spring steel and has slots cut lengthwise on its circumference. So, it holds the work with more grips. Collet chucks are used in capstan lathes and automatic lathes for holding bar stock in production work.

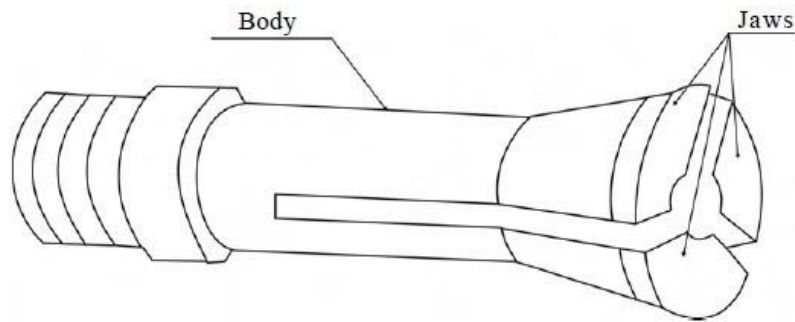

Face plate

Faceplate is used to hold large, heavy and irregular shaped workpieces which can not be conveniently held between centres. It is a circular disc bored out and threaded to fit to the nose of the lathe spindle. It is provided with radial plain and 'T' – slots for holding the work by bolts and clamps.

Driving plate

The driving plate is used to drive a workpiece when it is held between centres. It is a circular disc screwed to the nose of the lathe spindle. It is provided with small bolts or pins on its face. Workpieces fitted inside straight tail carriers are held and rotated by driving plates.

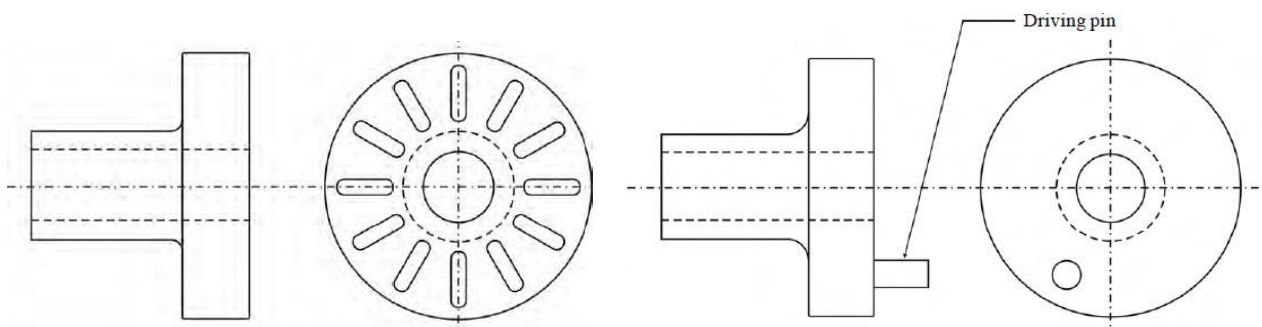

Fig: Face plate

Fig: Driving plate

Catch plate

When a workpiece is held between centres, the catch plate is used to drive it. It is a circular disc bored and threaded at the centre. Catch plates are designed with 'U' – slots or elliptical slots to receive the bent tail of the carrier. Positive drive between the lathe spindle and the workpiece is affected when the workpiece fitted with the carrier fits into the slot of the catch plate.

Carrier

When a workpiece is held and machined between centres, carriers are useful in transmitting the driving force of the spindle to the work by means of driving plates and catch plates. The work is held inside the eye of the carrier and tightened by a screw. Carriers are of two types and they are:

1. Straight tail carrier
2. Bent tail carrier

Straight tail carrier is used to drive the work by means of the pin provided in the driving plate. The tail of the bent tail carrier fits into the slot of the catch plate to drive the work.

Mandrel

A previously drilled or bored workpiece is held on a mandrel to be driven in a lathe and machined. There are centre holes provided on both faces of the mandrel. The live centre and the dead centre fit into the centre holes. A carrier is attached at the left side of the mandrel. The mandrel gets the drive either through a catch plate or a driving plate. The workpiece rotates along with the mandrel.

There are several types of mandrels and they are:

1. Plain mandrel
2. Step mandrel
3. Gang mandrel
5. Collar mandrel
6. Cone mandrel
7. Expansion mandrel

Centres

Centres are useful in holding the work in a lathe between centres. The shank of a centre has Morse taper on it and the face is conical in shape. There are two types of centres namely

- (i) Live centre
- (ii) Dead centre

The live centre is fitted on the headstock spindle and rotates with the work. The centre fitted on the tailstock spindle is called dead centre. It is useful in supporting the other end of the work. Centres are made of high carbon steel and hardened and then tempered. So the tip of the centres are wear resistant.

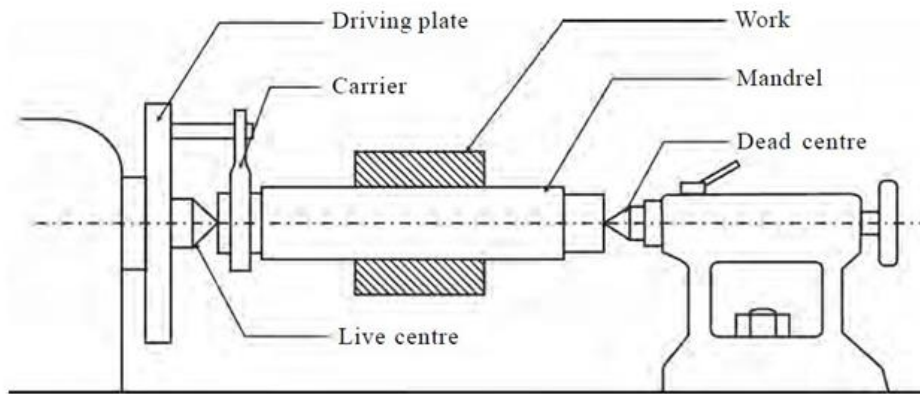

Fig 1.27 Holding a work between centres

Different types of centres are available according to the shape of the work and the operation to be performed. They are:

1. Ordinary centre
2. Ball centre
3. Half centre
4. Tipped centre
5. Pipe centre
6. Revolving centre
7. Inserted type centre

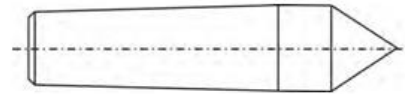

Fig : Ordinary centre

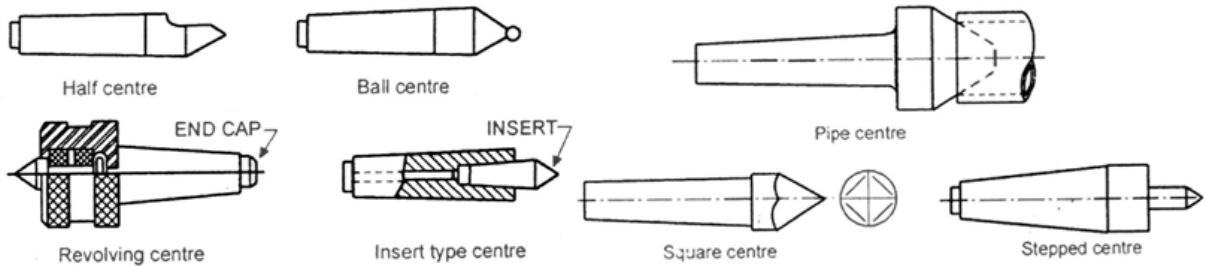

Fig: Types of centres

Rests

A rest is a mechanical device to support a long slender workpiece when it is turned between centres or by a chuck. It is placed at some intermediate point to prevent the workpiece from bending due to its own weight and vibrations setup due to the cutting force.

There are two different types of rests

1. Steady rest
2. Follower rest

Steady rest

Steady rest is made of cast iron. It may be made to slide on the lathe bed ways and clamped at any desired position where the workpiece needs support. It has three jaws. These jaws can be adjusted according to the diameter of the work. Machining is done upon the distance starting from the headstock to the point of support of the rest. One or more steady rests may be used to support the free end of a long work.

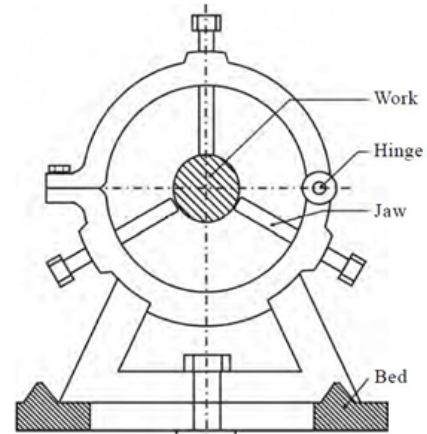

Follower rest

It consists of a 'C' like casting having two adjustable jaws to support the workpiece. The rest is bolted to the back end of the carriage. During machining, it supports the work and moves with the carriage. So, it follows the tool to give continuous support to the work to be able to machine along the entire length of the work. In order to reduce friction between the work and the jaws, proper lubricant should be used.

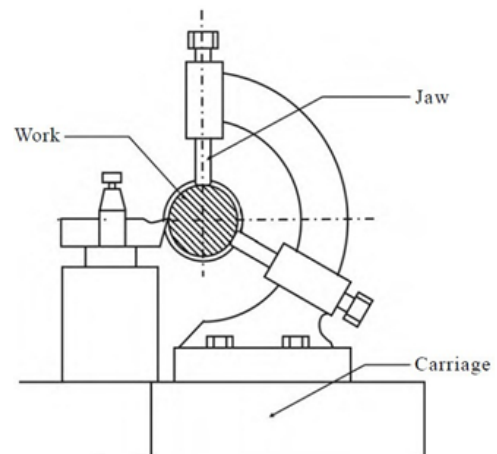

Operations performed in a lathe

Various operations are performed in a lathe other than plain turning. They are:

1. Facing
2. Turning
 - a. Straight turning
 - b. Step turning
3. Chamfering
4. Grooving
5. Forming
6. Knurling
7. Undercutting
8. Eccentric turning
9. Taper turning
10. Thread cutting
11. Drilling
12. Reaming
13. Boring
14. Tapping

Facing

Facing is the operation of machining the ends of a piece of work to produce flat surface which is square with the axis. The operation involves feeding the tool perpendicular to the axis of rotation of the work.

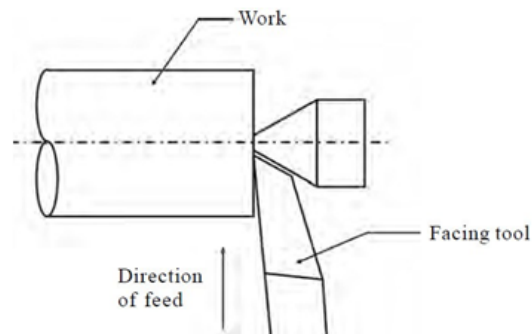

Fig 1.31 Facing

Turning

Turning in a lathe is to remove excess material from the workpiece to produce a cylindrical surface of required shape and size.

Straight turning

The work is turned straight when it is made to rotate about the lathe axis and the tool is fed parallel to the lathe axis. The straight turning produces a cylindrical surface by removing excess metal from the workpieces.

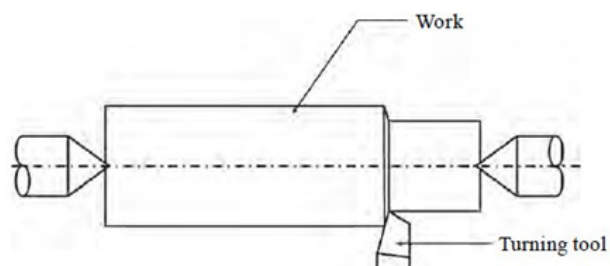

Fig 1.32 Straight turning

Step turning

Step turning is the process of turning different surfaces having different diameters. The work is held between centres and the tool is moved parallel to the axis of the lathe. It is also called shoulder turning.

Chamfering

Chamfering is the operation of beveling the extreme end of the workpiece. The form tool used for taper turning may be used for this purpose. Chamfering is an essential operation after thread cutting so that the nut may pass freely on the threaded workpiece.

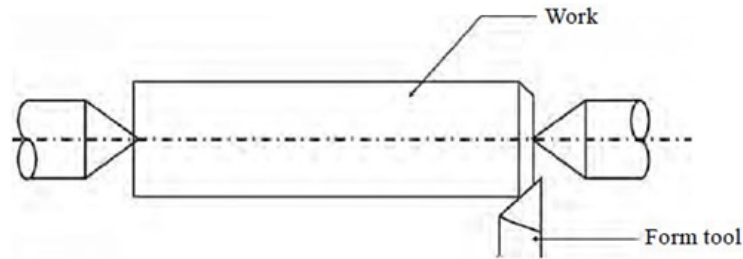
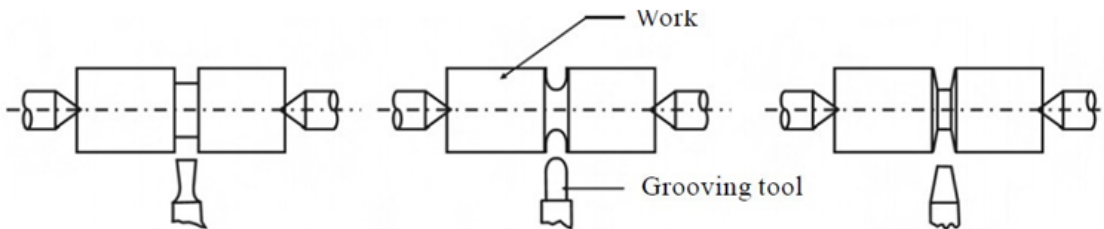

Fig 1.33 Chamfering

Grooving

Grooving is the process of cutting a narrow groove on the cylindrical surface of the workpiece. It is often done at end of a thread or adjacent to a shoulder to leave a small margin. The groove may be square, radial or beveled in shape.



Undercutting

Undercutting is done (i) at the end of a hole (ii) near the shoulder of stepped cylindrical surfaces (iii) At the end of the threaded portion in bolts. It is a process of enlarging the diameter if done internally and reducing the diameter if done externally over a short length. It is useful mainly to make fits perfect. Boring tools and parting tools are used for this operation.

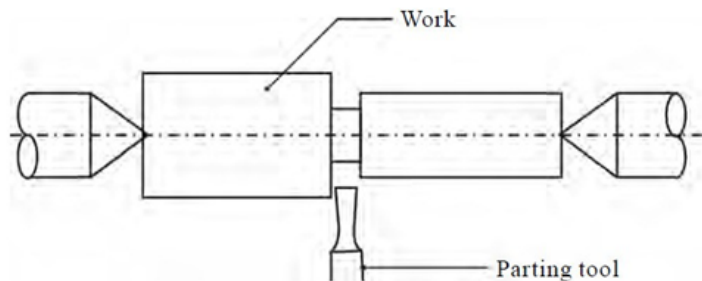

Forming

Forming is a process of turning a convex, concave or any irregular shape. For turning a small length formed surface, a forming tool having cutting edges conforming to the shape required is fed straight into the work.

Knurling

Knurling is the process of embossing a diamond shaped pattern on the surface of the workpiece. The knurling tool holder has one or two hardened steel rollers with edges of required pattern. The tool holder is pressed against the rotating work. The rollers emboss the required pattern. The tool holder is fed automatically to the required length. Knurls are available in coarse, medium and fine pitches. The patterns may be straight, inclined or diamond shaped.

The purpose of knurling is

1. To provide an effective gripping surface
2. To provide better appearance to the work
3. To slightly increase the diameter of the work

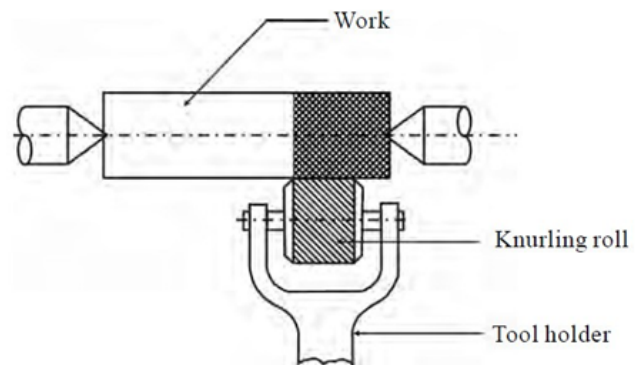

Taper turning

Taper

A taper may be defined as a uniform increase or decrease in diameter of a piece of work measured along its length.

Taper turning methods

1. Form tool method
2. Compound rest method
3. Tailstock set over method
4. Taper turning attachment method
5. Combined feed method

(i) Form tool method

A broad nose tool is ground to the required length and angle. It is set on the work by providing feed to the cross-slide. When the tool is fed into the work at right angles to the lathe axis, a tapered surface is generated. This method is limited to turn short lengths of taper only. The length of the taper is shorter than the length of the cutting edge. Less feed is given as the entire cutting edge will be in contact with the work.

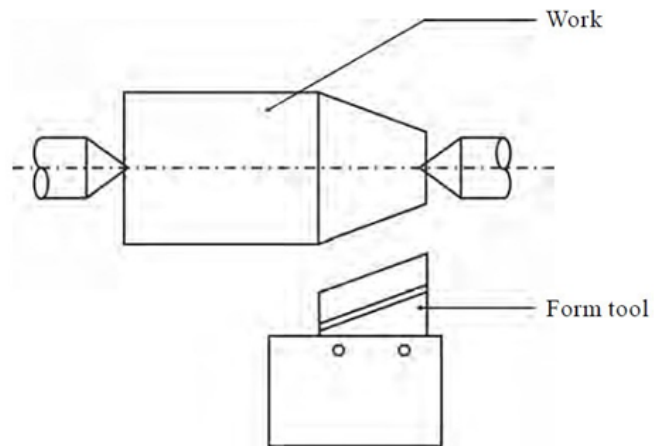

(ii) Compound rest method

The compound rest of the lathe is attached to a circular base graduated in degrees, which may be swivelled and clamped at any desired angle. The angle of taper is calculated using the formula:

$$\tan\theta = \frac{D - d}{2l}$$

where D = Larger diameter

d = Smaller diameter

l = Length of the taper

θ = Half taper angle

The compound rest is swivelled to the angle calculated as above and clamped. Feed is given to the compound slide to generate the required taper.

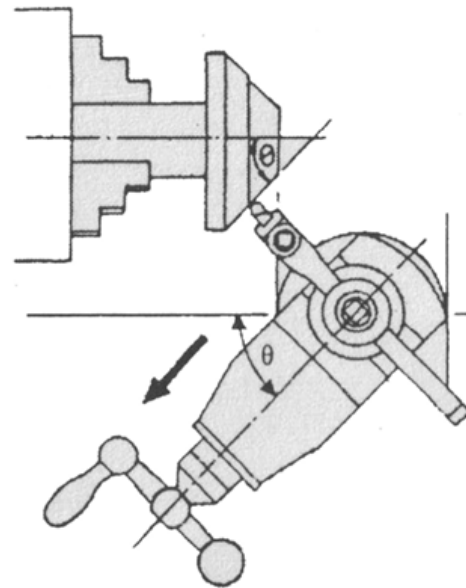

Taper turning by swivelling the compound rest

(iii) Tailstock set over method

Turning taper by the set over method is done by shifting the axis of rotation of the workpiece at an angle to the lathe axis and feeding the tool parallel to the lathe axis. The construction of tailstock is designed to have two parts namely the base and the body. The base is fitted on the bed guide ways and the body having the dead centre can be moved at cross to shift the lathe axis.

The amount of set over (s) can be calculated as follows:

$$\text{setover, } s = L * \frac{D - d}{2l}$$

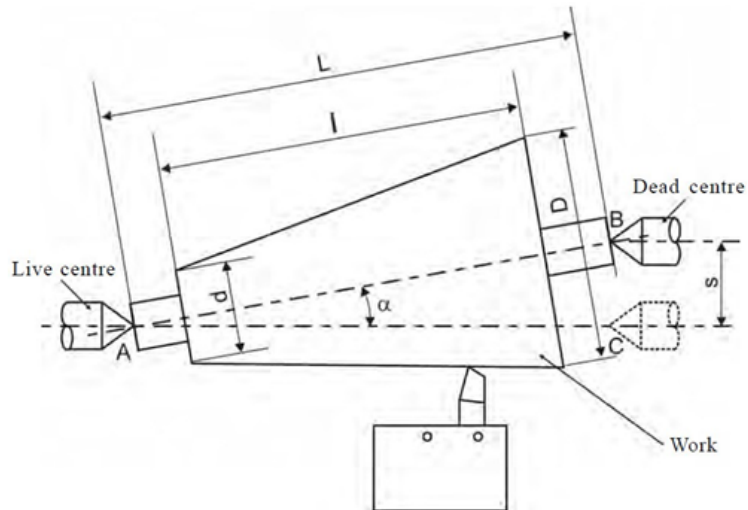

The dead centre is suitably shifted from its original position to the calculated distance. The work is held between centres and longitudinal feed is given by the carriage to generate the taper. The advantage of this method is that the taper can be turned to the entire length of the work. Taper threads can also be cut by this method. The amount of set over being limited, this method is suitable for turning small tapers (approx. upto 8°). Internal tapers cannot be done by this method.

(iv) Taper turning by an attachment

The taper attachment consists of a bracket which is attached to the rear end of the lathe bed. It supports a guide bar pivoted at the centre. The bar having graduation in degrees may be swiveled on either side of the zero graduation and set at the desired angle to the lathe axis. A guide block is mounted on the guide bar and slides on it. The cross slide is made free from its screw by removing the binder screw. The rear end of the cross slide is tightened with the guide block by means of a bolt. When the longitudinal feed is engaged, the tool mounted on the cross slide will follow the angular path as the guide block will slide on the guide bar set at an angle of the lathe axis. The depth of cut is provided by the compound slide which is set parallel to the cross-slide. The advantage of this method is that long tapers can be machined. As power feed can be employed, the work is completed at a shorter time. The disadvantage of this method is that internal tapers cannot be machined.

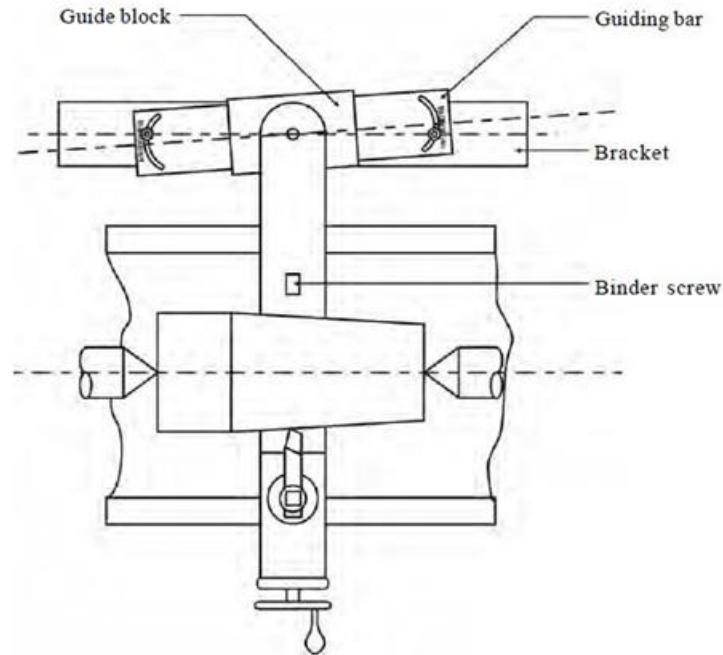

Thread cutting

Thread cutting is one of the most important operations performed in a lathe. The process of thread cutting is to produce a helical groove on a cylindrical surface by feeding the tool longitudinally. The job is revolved between centres or by a chuck. The longitudinal feed should be equal to the pitch of the thread to be cut per revolution of the work piece.

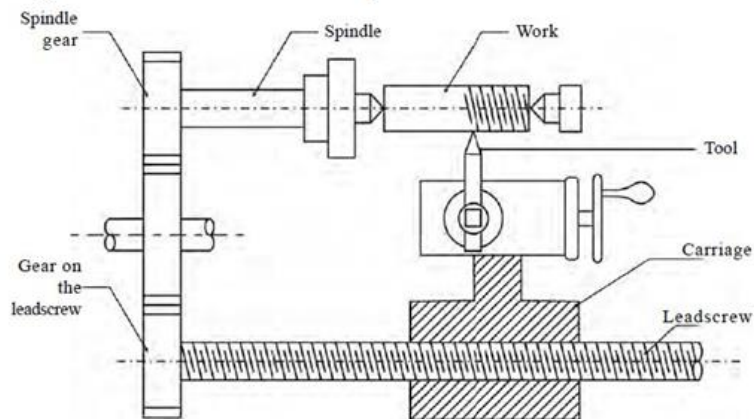

Tools used in a lathe

Tools used in a lathe are classified as follows

A. According to the construction, the lathe tools are classified into three types

1. Solid tool
2. Brazed tipped tool
3. Tool bit and tool holders

B. According to the operation to be performed, the cutting tools are classified as

1. Turning tool
2. Thread cutting tool
3. Facing tool
4. Forming tool
5. Parting tool
6. Grooving tool
7. Boring tool
8. Internal thread cutting tool
9. Knurling tool

C. According to the direction of feed movement, the following tools are used

1. Right hand tool
2. Left hand tool
3. Round nose tool

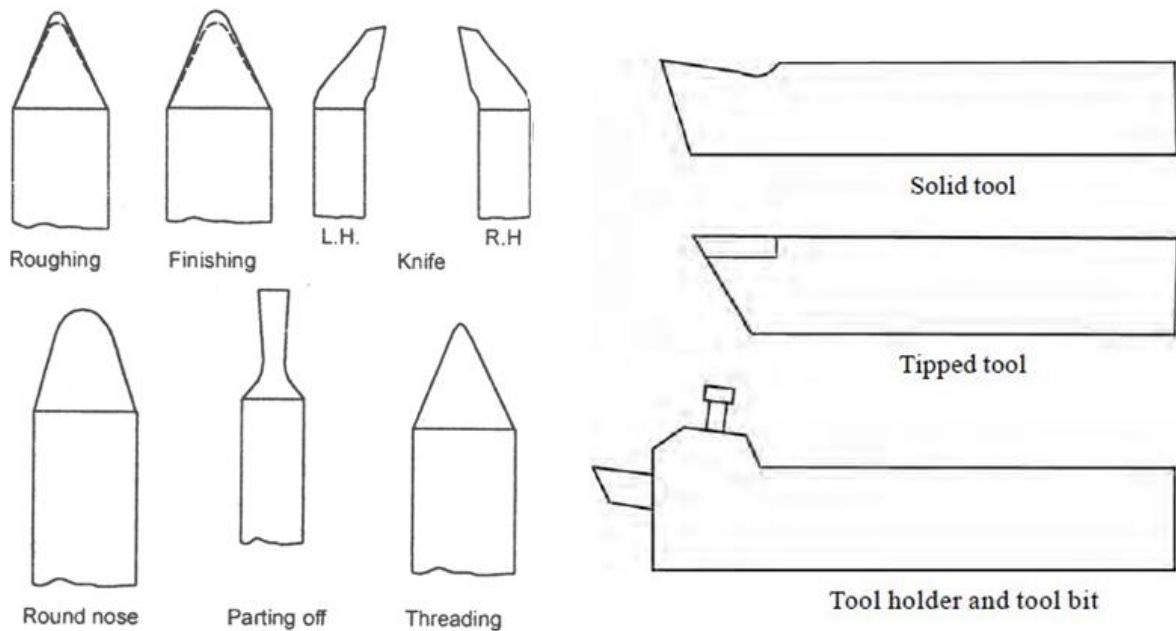

Fig : Types of tools

PLANER

INTRODUCTION

- Planing is one of the basic operations performed in machining work and is primarily intended for machining large flat surfaces. These surfaces may be Horizontal, Vertical or Inclined.
- In this way, the function of a Planing Machine is quite similar to that of a Shaper except that the former is basically designed to undertake machining of such large and heavy Jobs which are almost impracticable to be machined on a Shaper or Milling machine, etc.
- Planing Machine proves to be most economical so far as the machining of large flat surfaces is concerned.
- However, a Planing Machine differs from a Shaper in that for machining, the work, loaded on the Table, reciprocates past the stationary Tool in a Planer, whereas in a Shaper, the tool reciprocates past the stationary work.

WORKING PRINCIPLE OF A PLANER

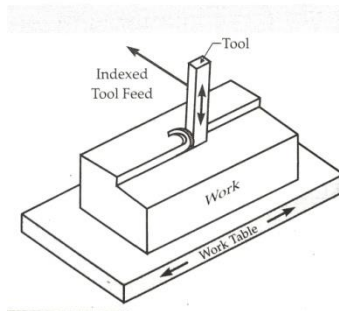

The Principle involved in machining a Job on a Planer is illustrated in Fig. Here, it is almost a reverse case to that of a Shaper.

The work is rigidly held on the Work table or Platen of the machine. The tool is held vertically in the Tool-head mounted on the Cross-rail. The Work table, together with the Job, is made to reciprocate past the vertically held tool.

The indexed feed, after each cut, is given to the tool during the idle stroke of the Table.

MACHINE SIZE AND SPECIFICATIONS

Planers are made in different sizes and they are specified by the following main dimensions :

- **Horizontal distance between the two vertical Housings.**
- **Vertical distance between the Table top and the Cross-rail, when the later is in its topmost position.**
- **Maximum length of Table travel or Length of stroke.**
- Length of Bed.
- Length of Table.
- Method of driving Common or Individual.
- Method of driving the Table Geared or Hydraulic, etc. H.P. (or kW) of Motor.
- Number of additional Tool Heads required.

MAIN PARTS AND THEIR FUNCTIONS

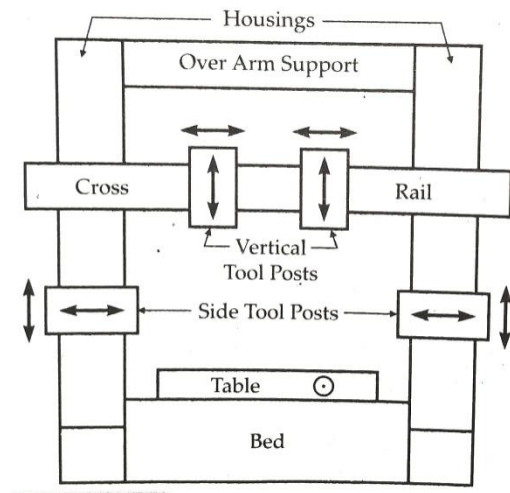

Main parts of a planer are

1. Bed
2. Table or platen
3. Housings or columns
4. Cross-rail
5. Tool heads
6. Controls

1. Bed

- It is very large and heavy Cast iron Structure, which is provided with cross ribs for additional strength and stiffness, as the same supports the whole Structure of the Machine over it.
- In case of Large Planers the Bed is sometimes made in two parts, which are properly machined and then bolted together to form a single length of Bed.
- It is about two times longer than the Table it carries over it. At its top, it carries either V-ways, or Flat ways (only in case of large planers), to support and guide the table. All the ways are Straight, Parallel, accurately machined and scraped. These Ways should be constantly lubricated.

2. Table

- The Table or Platen (as it is frequently called) is also made of cast iron with an accurately machined top.
- It may be a single piece Casting or made in two pieces, bolted together in the same ways as the two piece bed.
- It carries a Box type construction, provided with strengthening ribs under it in order to make it strong enough to support the heavy work over it. At its Top it carries longitudinal T-slots and holes to accommodate the clamping bolts and other devices.
- The work is directly mounted and clamped on the table by means of various devices using the T-slots and holes. Under the table, Chip pockets are cast integral with it for collecting and removing the chips.
- On its side, the table carries adjustable Stops to reverse its motion at the end of each stroke.
- A special feature in planer Tables is the provision of a suitable Safety device to prevent the heavily loaded reciprocating table from running out in case of an Electrical or Mechanical failure. A common safety device is a large Cutting tool bolted under the table on its both sides and fixing of stop blocks on the bed on each side. In case of running away of the table, the tool will take a deep cut into the stop block and thus absorb the whole kinetic energy of the table, bringing it to a halt without damage to the machine or workman.

3. Housings or Columns

- They are also sometimes called Columns or Uprights.
- These vertical members are situated on both sides in case of a Double Housing Planer and on one side only in case of an Open side Planer.
- Inside them, they carry the different mechanisms for transmission of power to the upper parts of the machine, from the main drive.
- At their front, they are very accurately machined to form Vertical ways along which the cross rail slides up and down.
- Where Side Tool-heads are used, they also slide vertically along the same guide ways.

4. Cross-rail

- It is a horizontal member of heavy structure which connects the two Vertical housings of the machine. It provides additional rigidity to the machine.
- By means of the Elevating screws it can be moved up and down along the ways provided on the housings.
- Clamps are provided to lock the Cross-rail in any desired position along the columns. These Clamps may be operated by hand or power. Also a suitable Levelling device is incorporated to ensure that the Cross-rail is perfectly horizontal before clamping.
- In order that the Cross-rail is moved up or down uniformly on both ends, both the Elevating screws are rotated simultaneously by a horizontal shaft, mounted on the top of the machine, through a set of bevel gears.
- Accurately finished ways are provided at the front of the Cross-rail for the two Vertical Tool heads. Inside the rail are provided the Feed rods for vertical Power feed and Cross feed to the Tools.

5. Tool head

- The Planer Tool heads, both in construction as well as operation, resemble very much with the Shaper Tool heads.
- At the most four Tool heads can be fitted in a planer and any or all of them can be used at a time. Two Tool heads can be fitted in vertical position on the Cross-rail and the other two on the Vertical Columns. Each Column carries one Side Tool head.
- All the four Tool heads work independently, such that they can operate separately or simultaneously, as desired.

- The Tool heads on the Cross-rail can travel horizontally, along the rail. They can also be raised or lowered by moving the Cross-rail up or down.
- Also, the tools can be fed downwards by rotating the Down feed screw. Similarly, the Side Tool heads can move up and down along the vertical Column ways. Also their tools can be fed horizontally into the Job or at a desired inclination. A Swivel plate is incorporated. This enables the Tool head to swivel through an angle of 70° on either side from its normal position.
- Exactly in the same way as in a Shaper head, the Apron of the Planer head can also be set at an inclination whenever needed. Both hand and power feeds can be employed, for all the Tool heads, but power feeds are commonly used. The Clapper block is also hinged, as in Shaper head, in order to avoid scratching of machined surface by the tool during the idle stroke.

6. Controls

Various Controls for starting, operating and stopping the various mechanisms, automatic cutting off speed and feed regulation and similar other functions are usually provided within a quick approach of the operator of the machine.

TYPES OF PLANERS

A fairly large variety of Planers of different designs of sizes is available in the market. They are, however, classified broadly into the following types :

- **Standard or Double housing Planer**
- **Open side Planer**
- **Planer Miller**
- Plate Planer
- Pit Planer
- Divided table Planer and
- Plano-Guillotine Shearing Machine.

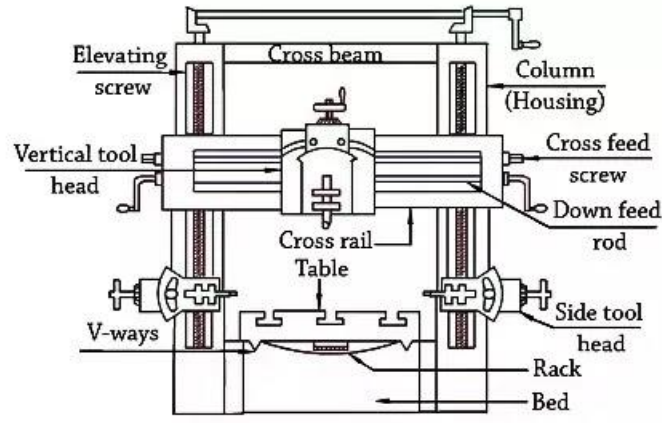

Double housing planer

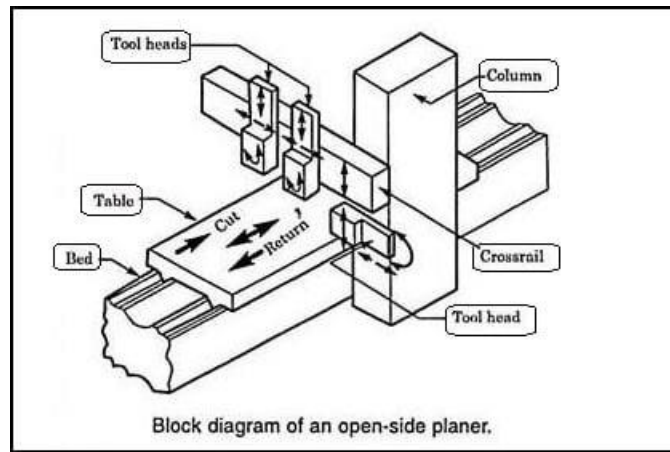

Block diagram of an open-side planer.

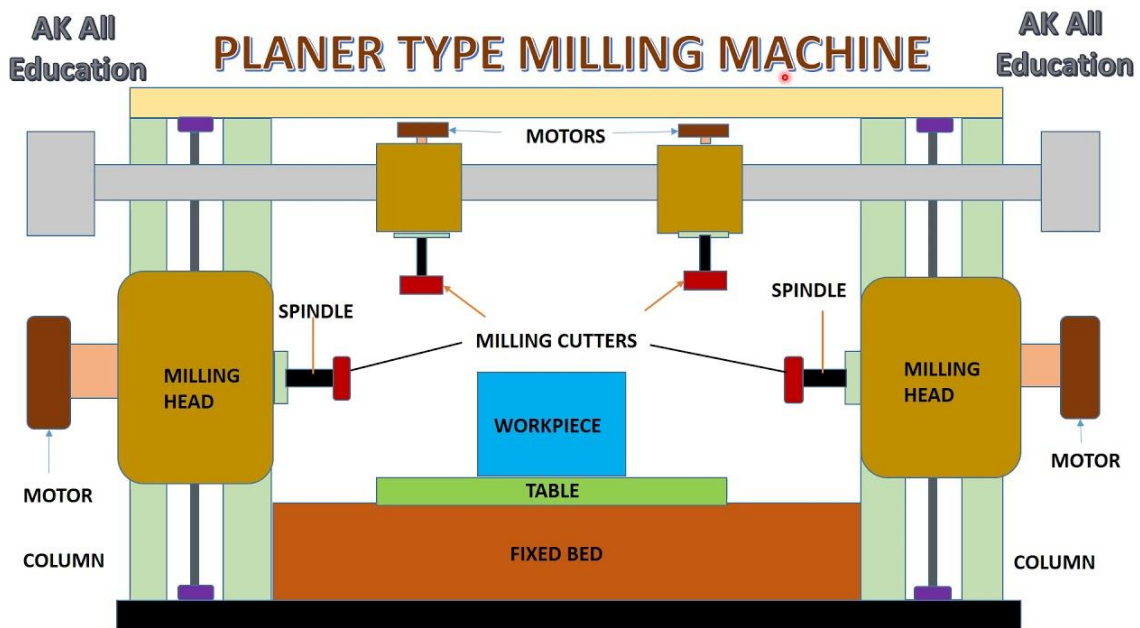

QUICK RETURN MECHANISMS FOR PLANER TABLES

The common methods used for providing a Quick return motion to the machine table are the following :

- i. Belt Drive
- ii. Crank drive
- iii. Direct reversible drive
- iv. Hydraulic drive

BELT DRIVE MECHANISM

Most of the Common types of Planers carry this system of drive for the Quick return of their tables. The main features of this drive are shown in Fig. It consists of the main Driving Motor situated over the housings. This motor drives the Countershaft through an open V-belt. The countershaft, at its extreme, carries two Driving Pulleys; one for Open belt and the other for Cross belt.

The main Driving shaft is provided below the bed. One end of it passes through the Housing and carries a Pinion, which meshes with the Rack provided under the table of the machine, as shown. The other end of this shaft carries two pairs of pulleys each pair-consisting of a fast pulley and a loose pulley. One of these pairs is connected to one of the driving pulleys by means of an Open belt and the other to the second driving pulley by means of a Cross belt. A Speed Reduction Gear Box is mounted on the main driving shaft and the same is incorporated between the pinion and the pairs of driven pulleys, as shown in the diagram.

One set of the above pulleys is used for the Forward motion of the table and the other set for Backward or Return motion. In the given diagram, the Cross belt will be used for forward motion and the Open belt for return motion. Note that the driving pulley on the countershaft for cross belt is smaller than the pair of fast and loose pulleys for the same. Against this, the driving pulley on the countershaft for open belt is bigger than the pair of fast and loose pulleys for the same. Consequently, therefore, for same speed or number of revolutions of the countershaft the main driving shaft will run faster when connected by open belt than when the cross belt is used. It is obvious, therefore, that the return stroke will be faster than the forward stroke.

It should also be noted here that the pulleys are so arranged that when the cross belt is on the fast pulley, i.e., in forward stroke, the open belt will be on the loose pulley and its reverse will take place during the return stroke. In order that this relative shifting of belt may take place automatically at the end of each stroke, without stopping the machine, a Belt shifter and its Operating lever are provided on the machine. Trip dogs are mounted, one each at both ends, on the table. At the end of each stroke, these dogs strike against the Operating lever alternately and the belt shifted accordingly. Thus, the table movement is reversed automatically.

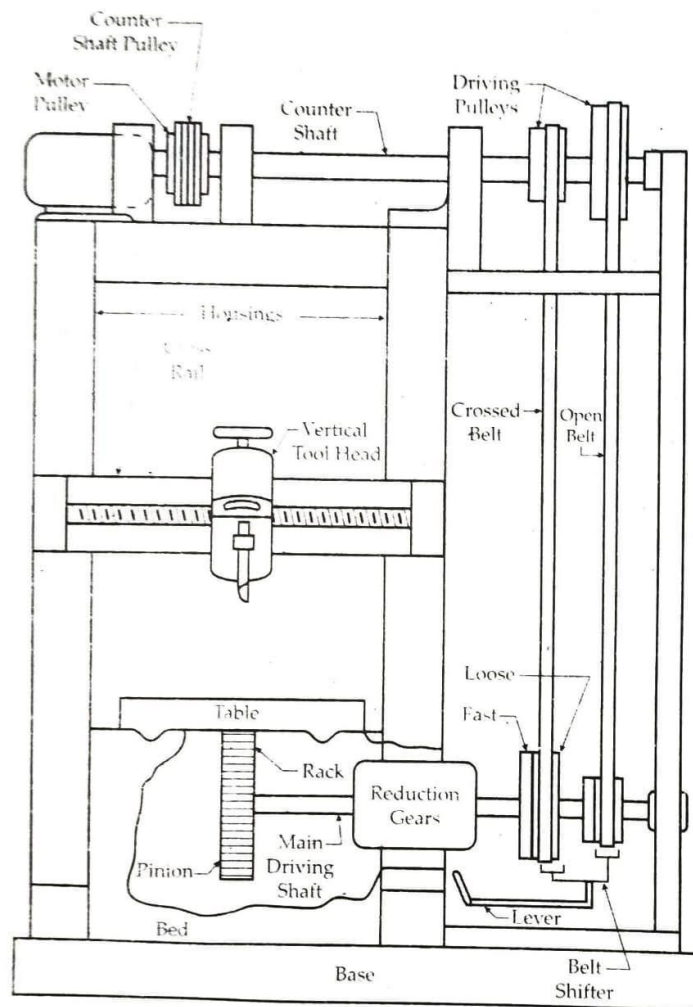

APPLICATION AREAS OF PLANER:

A planer performs the same operations as performed by a shaper, with the main difference that the workpieces handled on a planer are larger and heavier than those machined on a shaper. Also the surfaces machined on a planer are much larger and wider than those produced on a shaper.

The common operations performed on a planer:

1. Machining horizontal flat surfaces
2. Machining vertical flat surfaces
3. Machining angular surfaces, including dovetails
4. Machining different types of slots and grooves
5. Machining curved surfaces

COMPARISON BETWEEN A PLANER AND A SHAPER

<i>Planer</i>	<i>Shaper</i>
1. It is a heavier, more rigid and costlier machine.	It is a comparatively lighter and cheaper machine.
2. It requires more floor area.	It requires less floor area.
3. It is used for machining large flat surfaces—horizontal, vertical and inclined.	It is also used for the same purposes but for relatively smaller surfaces.
4. The work is usually clamped directly on the machine table by means of suitable fixtures or clamping devices.	The work may be clamped directly on the table or held in a vice or chuck.
5. Cutting takes place by reciprocating the work under the tool.	Cutting takes place by moving the cutting tool over the job.
6. Indexed feed is given to the tool during the idle stroke of the work table.	Indexed feed is given to the work during the idle stroke of the ram.
7. Heavier cuts and coarse feeds can be employed.	Very heavy cuts and coarse feeds cannot be employed.
8. Several tools can be mounted and employed simultaneously, usually four as a maximum, facilitating a faster rate of production.	Usually only one tool is used on a shaper.
9. Because of its large stroke length and table size a number of jobs, requiring machining of identical shapes, can be held in series and machined simultaneously in a single setting.	This is not possible on shaper until and unless the job and surface sizes are too small, which can be conveniently held on the table, say in a vice.
10. The tools used on a planer are larger, heavier and stronger than those used on a shaper.	The tools used on a shaper are smaller and lighter.

MILLING MACHINE

INTRODUCTION

- ✚ Milling is the name given to the machining process in which the removal of metal takes place due to the cutting action of a Revolving Cutter when the work is fed past it.
- ✚ The Revolving cutter is held on a Spindle or Arbor and the work, clamped on the Machine Table, fed past the same. In doing so, the teeth of the cutter remove the metal, in the form of Chips, from the surface of the work to produce the desired shape.
- ✚ Milling machines are Capable to perform a large number of operations which no other single Machine Tool can perform. At the same time, it gives production at a fairly high rate and within very close limits of dimensions.
- ✚ That is why, in many cases, it has largely replaced other Machine tools like Shapers, Planers, Slotters, etc., but for small and medium size jobs only ; as it will prove to be too slow for machining very long jobs.
- ✚ For small and medium jobs, the Milling machine gives probably the fastest production with very high accuracy. For this reason, it has gained a very wide application in mass production work. Obviously, therefore, it is a very Versatile Machine Tool.

WORKING PRINCIPLE IN MILLING

The working principle, employed in the metal removing operation on a Milling machine, is that the work is rigidly clamped on the table of the machine, or held between centres, and revolving multiteeth cutter mounted either on a Spindle or an Arbor. The Cutter revolves at a fairly high speed and the work fed slowly past the cutter, as shown in Fig. The work can be fed in a vertical, longitudinal or cross direction. As the work advances, the cutter-teeth remove the metal from the work surface to produce the desired shape.

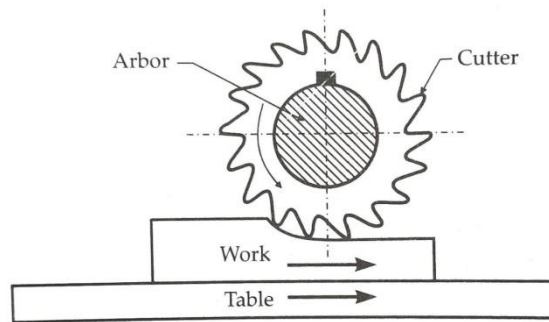

TYPES OF MILLING MACHINES

1. COLUMN AND KNEE TYPE MILLING MACHINES

These machines are all General purpose machines and have a Single Spindle only. They derive their name ‘Column and Knee’ type from the fact that the work table is supported on a knee like Casting, which can slide in vertical direction along a Vertical Column. These machines, depending upon the spindle position and table movements, are further classified as follows :

- (a) Hand milling machine,
- (b) Plain or Horizontal milling machine,
- (c) Vertical Milling machine,
- (d) Universal Milling machine, and
- (e) Omniversal Milling machine.

2. FIXED BED TYPE OR MANUFACTURING TYPE MILLING MACHINES

These machines, in comparison to the Column and Knee type, are more sturdy and rigid, heavier in weight and larger in size. They are not suitable for tool room work. Most of these machines are either Automatic or Semi-automatic in operation. They may carry a Single or Multiple Spindles. The common operations performed on these machines are Slot cutting, Grooving, Gang milling and Facing. Also, they facilitate machining of many jobs together, called Multi-piece Milling. Their further Classification is as follows ;

- (a) Plain Type (having Single Horizontal Spindle).
- (b) Duplex Head (having Double Horizontal Spindles).
- (c) Triplex Head (having two Horizontal and one Vertical Spindle).
- (a) Rise and Fall type (for Profile Milling)

3. PLANER TYPE MILLING MACHINES

They are used for heavy work. Upto a maximum of Four Toolheads can be mounted over it, which can be adjusted vertically and transverse directions. It has a robust and massive construction like a Planer. In this case spindle carriers are mounted in place of the planer tool post, which are operated by individual motors.

4. PRODUCTION MILLING MACHINES

They are also Manufacturing Machines but differ from the above described machines in that they do not have a fixed bed. They include the following machines :

- (a) Rotary Table or Continuous Type
- (b) Drum Type, and
- (c) Tracer Controlled.

5. SPECIAL PURPOSE MILLING MACHINES

These machines are designed to perform a specific type of Operation only. They include the following machines :

- (a) Thread Milling Machine,
- (b) Profile Milling Machine,
- (c) Gear Milling or Gear Hobbing Machine,
- (d) Cam Milling Machine,
- (e) Planetary Type Milling Machine,
- (f) Double end Milling Machine,
- (g) Skin Milling Machine, and
- (h) Spar Milling Machine.

COLUMN AND KNEE TYPE MILLING MACHINES

Plain or Horizontal Milling Machine

Its principal parts are shown by means of a block diagram in Fig. The Vertical Column serves as Housing for Electricals, the Main drive, Spindle bearings, etc. The knee acts as a support for the Saddle, Worktable and other accessories like Indexing Head, etc. Overarm provides support for the Yoke which in turn, supports the free end of the Arbor. The arbor carrying the Cutter rotates about a horizontal axis. The Table can be given straight motions in three directions ; longitudinal, cross and vertical (up and down) but cannot be swivelled.

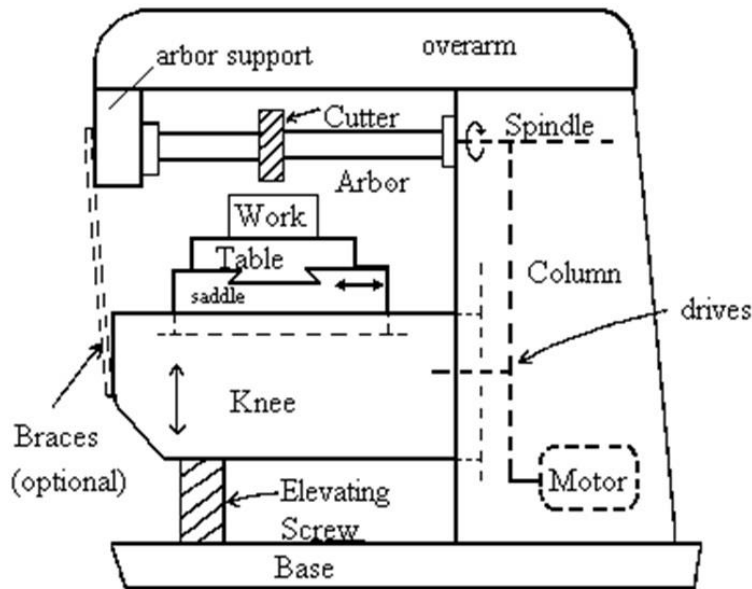

Horizontal Milling machine

For giving vertical movement to the table the knee itself, together with the whole unit above it, slides up and down along the ways provided in front of the Column. For giving cross movement to the table, the saddle is moved towards or away from the column along with the whole unit above it. A Brace is employed to provide additional support and rigidity to the arbor when a long arbor is used. Both hand and power feeds can be employed for the work.

Vertical Milling Machine

It derives its name from the vertical position of the Spindle. This machine is available in both types ; the Fixed bed type as well as Column and Knee type. Principal parts of the latter type are illustrated by means of block diagrams in Figs. It carries a Vertical Column on a heavy base. The Overarm in this machine is made integral with the column and carries a Housing at its front. This housing, called Head, can be Fixed type or Swivelling type. In Fixed type, the spindle always remains vertical and can be adjusted up and down. In Swivelling type, the Head can be swivelled to any desired angle to machine the inclined surfaces.

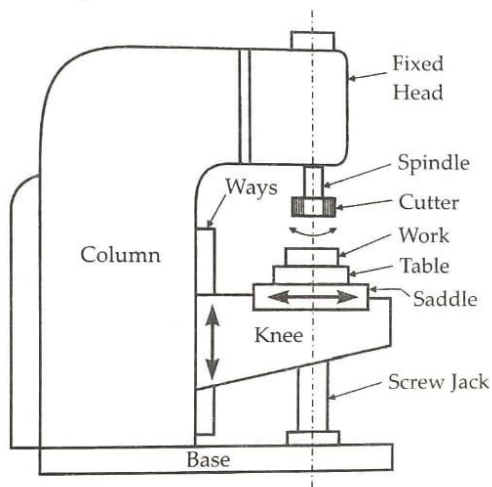

Fig. 11.3 Vertical Milling Machine with Fixed Head.

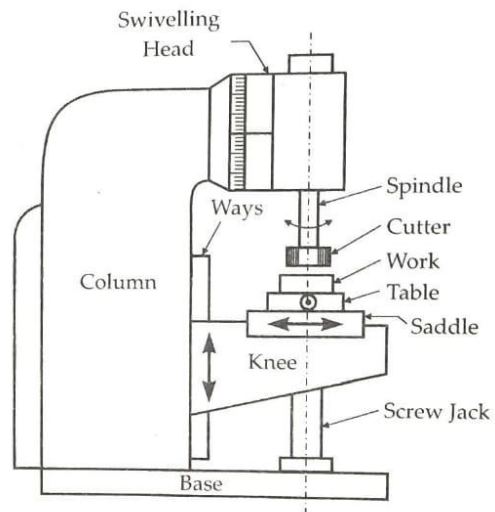

Fig. 11.4 Vertical Milling Machine with Swivelling Head.

The Knee carries an enclosed Screw jack, by means of which it is moved up and down along the parallel Vertical Guideways provided on the front side of the Column.

The Saddle is mounted on the knee and can be moved, along the horizontal guideways provided on the Knee, towards or away from the column. This enables the Table to move in cross direction.

The Table is mounted on guideways, provided on the saddle; which are in direction normal to the direction of the guideways on the Knee. By means of a Lead screw, provided under the table, the table can be moved in the longitudinal direction.

Thus, the work gets up and down movement by the knee, cross movement by saddle and longitudinal movement by the table. Power feeds can be employed to both the saddle and the table. Mostly Face Milling Cutters and Shell-end type Cutters are used on these machines.

Universal Milling Machine

It is the most versatile of all the Milling machines, and after lathe it is the most useful Machine Tool as it is capable of performing most of the machining operations. With its application, the use of a large number of other Machine tools can be avoided.

It differs from the Plain milling machine only in that the table can be given one more additional movement. Its table can be swivelled on the saddle in a horizontal plane. For this, Circular guideways are provided on the saddle along which it can be swivelled.

This special feature enables the work to be set at an angle with the cutter for milling helical and spiral flutes and grooves. Its Overarm can be pushed back or removed and a Vertical milling

head can be fitted in place of the arbor to use it as a Vertical Milling Machine. Detailed parts and various controls of a Universal milling machine are shown in Fig.

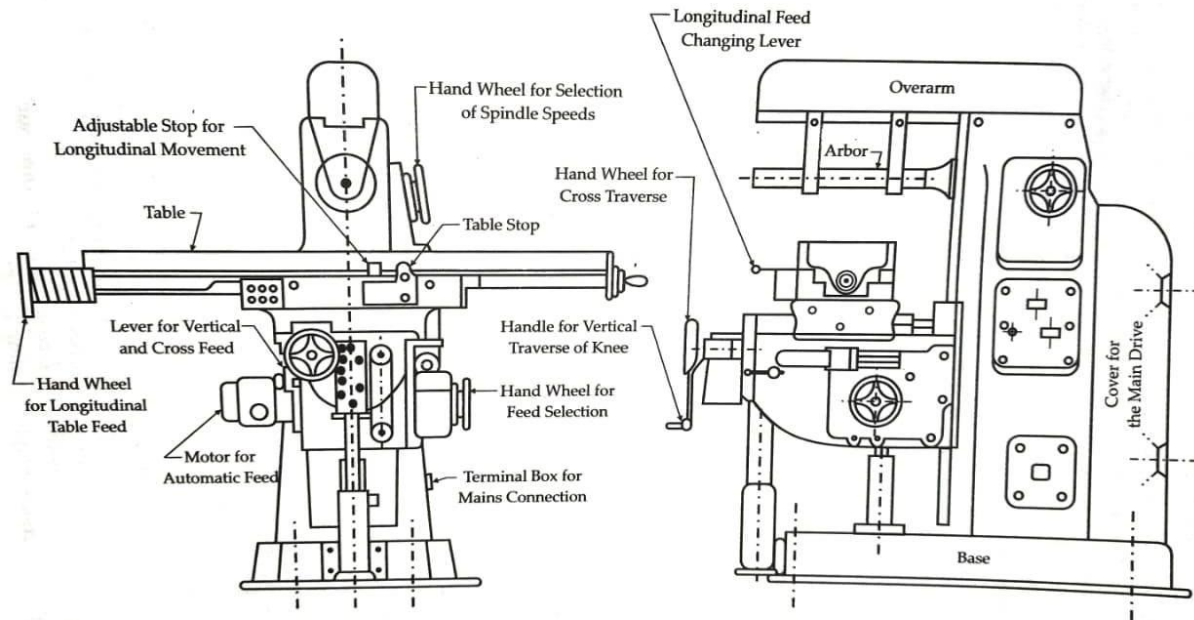

Omniversal Milling Machine

This is, in fact, a modified form of Plain milling machine and is provided with two Spindles, of which one is horizontal, as in Plain milling, and the other is carried by a Universal swivelling head.

Another special feature of this machine is that it carries, in addition to all the possible adjustments provided in a Universal Machine, two more adjustments. These adjustments are of the Knee, which can be swivelled about a horizontal axis to tilt the table and can be moved horizontally also.

These Special Features make it a very useful Machine Tool for tool room work as it facilitates various operations to be carried out in different planes and at different angles in a single setting of the work.

PRINCIPAL PARTS AND THEIR FUNCTIONS OF COLUMN AND KNEE TYPE MILLING MACHINE:

Main parts of all the Column and Knee type Milling Machines are similar, although the movements of the moving parts differ in them, as described earlier. All these machines essentially consists of the following main parts

1. Base

It is a heavy Casting provided at the bottom of the machine. It is accurately machined on both the top and bottom surfaces. It actually acts as load bearing member for all other parts of the machine. Column of the machine is secured to it. Also, it carries the Screw jack which supports and moves the Knee. In addition to this, it also serves as a Reservoir for the coolant.

2. Column

It is a very prominent part of a milling machine and is produced with enough care. To this, are fitted all the various parts and controls. On the front face of the column are made the vertical parallel ways in which the knee slides up and down. At its rear side, it carries the enclosed motor drive. Top of the column carries dovetail horizontal ways for the Over arm.

3. Knee

It is a rigid Casting, which is capable of sliding up and down along the vertical ways on the front face of the column. This enables the adjustment of the table height or, in other words, we can say the distance between the cutter and the job mounted on the table. The adjustment is provided by operating the Elevating jack, provided below the knee, by means of hand wheel or application of power feed. Machined horizontal ways are provided on the top surface of the knee for the cross traverse of the saddle, and hence the table.

4. Saddle

It is the intermediate part between the knee and the table and acts as a support for the latter. It can be adjusted crosswise, along the ways provided on the top of the knee, to provide cross feed to the table. At its top, it carries horizontal ways, along which moves the table during the longitudinal traverse.

5. Table

It acts as a support for the work. The latter is mounted on it either directly or held in the Dividing head.

It is made of cast iron, with its top surface accurately machine. Its top carries longitudinal T-slots to accommodate the Clamping bolts for fixing the work or securing the Fixtures. Also, the cutting fluid, after it is used, drains back to the Reservoir through these slots and then the pipe fitted for this purpose.

Longitudinal feed is provided to it by means of a hand wheel fitted on one side of the feed screw. Sometimes the hand wheels are provided on both sides or alternatively a Detachable Handle is provided, which can be engaged on either side.

Cross feed is provided by moving the saddle and Vertical feed by raising or lowering the knee. Both hand feed and power feed can be employed for all these movements.

In Universal milling machines the table is made to have a graduated circular base resting on the saddle. Such a table can be swivelled in a horizontal plane around the centre of its base and the graduations on the latter help in adjusting the required swivel.

6. Overarm

It is the heavy support provided on the top of both Plain and Universal milling machines. It can slide horizontally, along the ways provided on the top of the column, and adjusted to a desired position in order to provide support .to the projecting arbor by accommodating its free end in the Yoke. If further support is needed, to have additional rigidity, Braces can be employed to connect the Overarm and the Knee. Such a requirement is always there when many cutters are employed simultaneously.

FIXED BED TYPE OR MANUFACTURING TYPE MILLING MACHINES

Main parts of this type of machine are shown by means of a block diagram in Fig. It differs from the Column and Knee type Plain Milling Machine in that the table is mounted on a fixed bed instead of the saddle and knee and has a longitudinal travel only. It can neither move up and down nor crosswise.

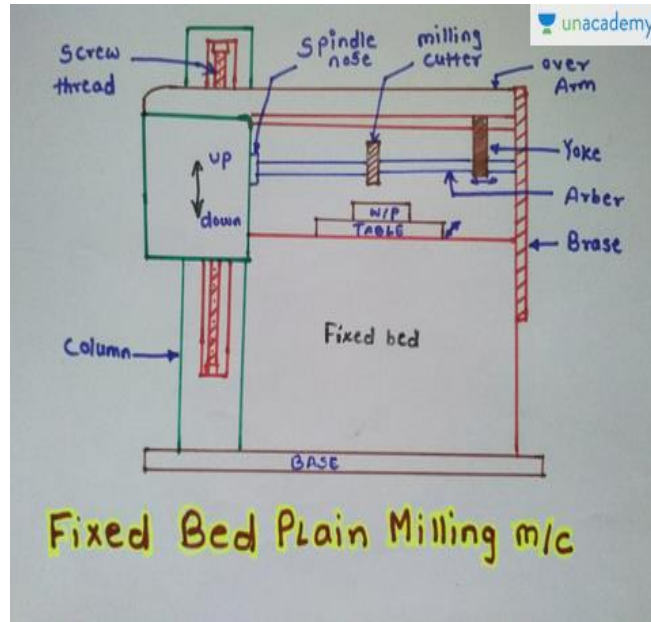

A rigid Vertical column carries parallel Vertical ways on which is mounted the Adjustable spindle head or Spindle carrier. This Spindle head carries the spindle to which the arbor can be fitted to carry the Cutter. The carrier can be moved up and down along the column ways to adjust the tool to the work.

MILING OPERATIONS

Milling, as has already been stated, is a process of metal cutting by means of a Multi-teeth Rotating Tool, called Cutter. The form of each tooth of the cutter is the same as that of a Single point tool. However, an important feature to be noted is that each tooth, after taking a cut, comes in operation again after some interval of time. This allows the tooth to cool down before the next cutting operation is done by it. Obviously this minimises the effect of heat developed.

With Cylindrical Cutters, the following two methods are commonly used for performing this operation :

1. **Up or Conventional Milling.** In this method of milling the cutter rotates in a direction opposite to that in which the work is fed.
2. **Down or Climb Milling.** In this method the direction of rotation of the Cutter coincides with the direction of work feed.

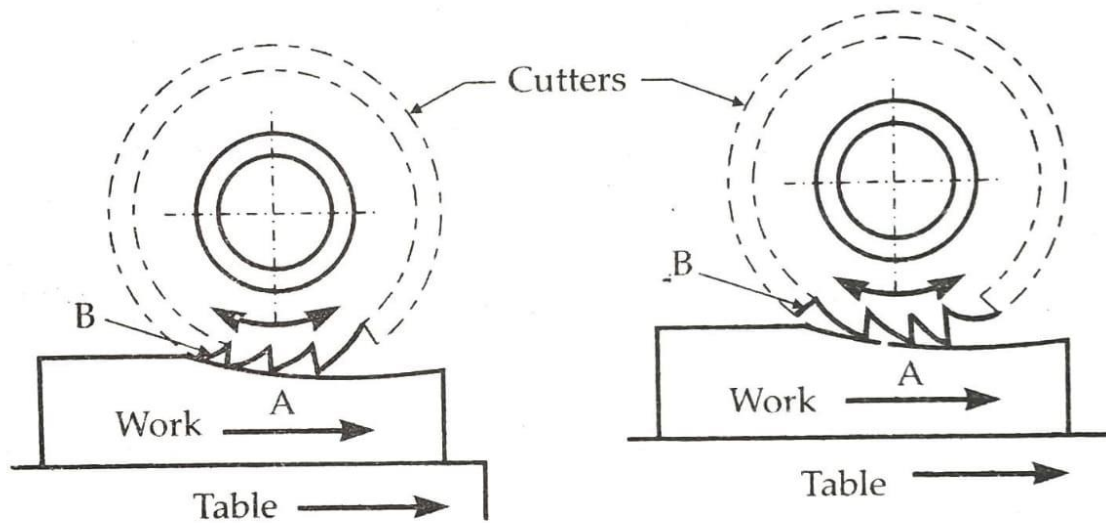

Up Milling

Down Milling

The above relative directions of movements of the Cutter and Work should be noted at the point of contact between the two. On comparing Figs you will find that the shape of chip (shaded area between points A and B) removed by the cutter in both the cases is the same, but an important difference is that in Conventional Milling, as the cut proceeds, the chip thickness increases gradually; as from A to B. Against this, the chip thickness decreases in case of Climb Milling. In other words we can say that the Chip thickness in Conventional Milling, is minimum (zero) at the start of the cut and maximum at the end of the cut, whereas in Climb or Down Milling, it is a reverse case, i.e., maximum in the beginning and zero at the end.

The selection of a particular method; of the above two, depends upon the nature of work. The former method, i.e., Conventional Milling is commonly used for machining Castings and Forgings since this method enables the cutter to dig-in and start the cut below the hard upper surface. The second method, i.e., Climb milling is particularly useful for finishing operations and small work such as Slot cutting, Milling grooves, Slitting, etc. It gives a better surface finish.

TYPES OF MILLING OPERATIONS

A large variety of components are machined on a Milling Machine involving various types of operations. These Operations are broadly classified as follows:

- Plain or Slab Milling
- Face Milling

- Angular Milling
- Form Milling
- Straddle Milling
- Gang Milling

PLAIN OR SLAB MILLING

It is the process which is employed for machining a flat surface, parallel to the axis of the cutter, by using a Plain or slab milling cutter, as shown in Fig.

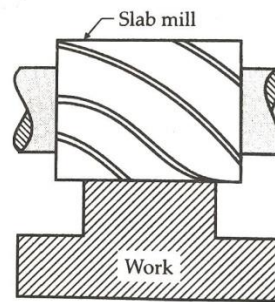

When a very wide surface is to be machined, it is advisable to use the Interlocking Teeth Plain Milling Cutters instead of simple Slab Mills. In using them, they should be so arranged that the axial forces are directed towards each other so as to force the cutters closer as the operation proceeds.

FACE MILLING

This milling process is employed for machining a flat surface which is at right angles to the axis of the rotating cutter. The cutter used in this process is the face milling cutter.

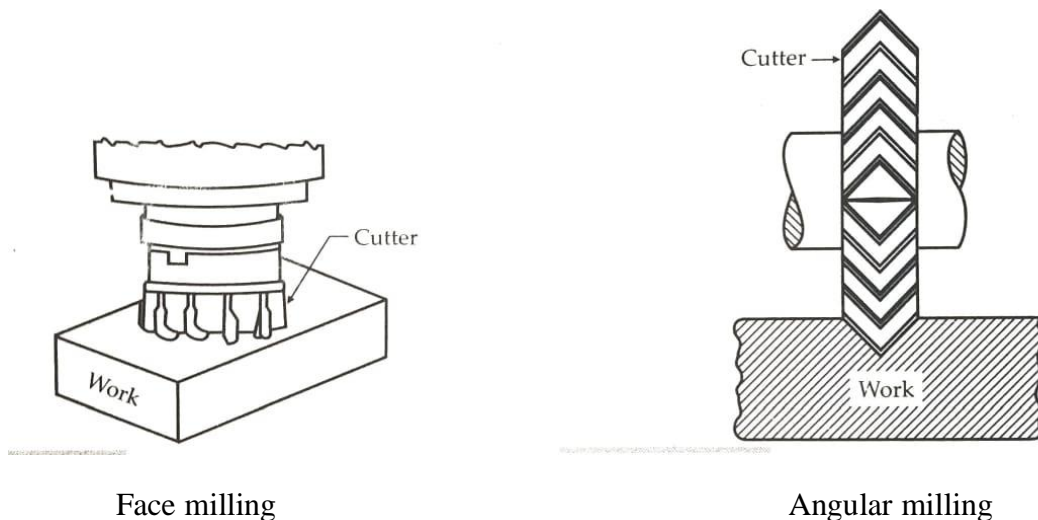

ANGULAR MILLING

It is the milling process which is used for machining a flat surface at an angle, other than a right angle to the axis of the revolving cutter. The cutter used may be a Single or Double Angle Cutter, depending upon whether a single surface is to be machined or two mutually inclined surfaces simultaneously.

FORM MILLING

This milling process is employed for machining those surfaces which are of irregular shapes. The cutter used, called a Form Milling Cutter, will have the shape of its cutting teeth conforming to the profile of the surface to be produced.

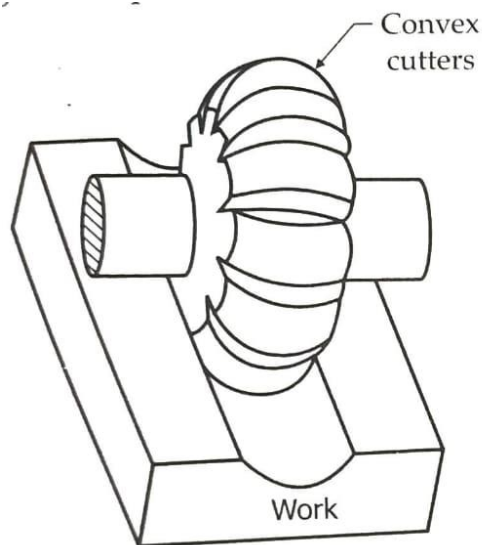

Form milling

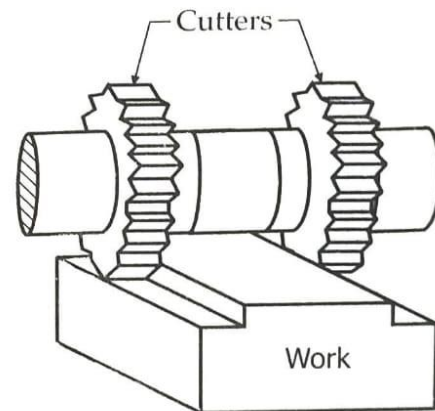

straddle milling

STRADDLE MILLING

It is a milling operation in which a pair of side milling cutters is used for machining two parallel vertical surfaces of a work piece simultaneously.

GANG MILLING

It is the name given to a milling operation which involves the use of a combination of more than two cutters, mounted on a common arbor, for milling a number of flat horizontal and vertical surfaces of a work-piece simultaneously. This combination may consist of only Side Milling Cutters or of Plain and Side Milling Cutters both. Figure shows the Gang Milling Operation.

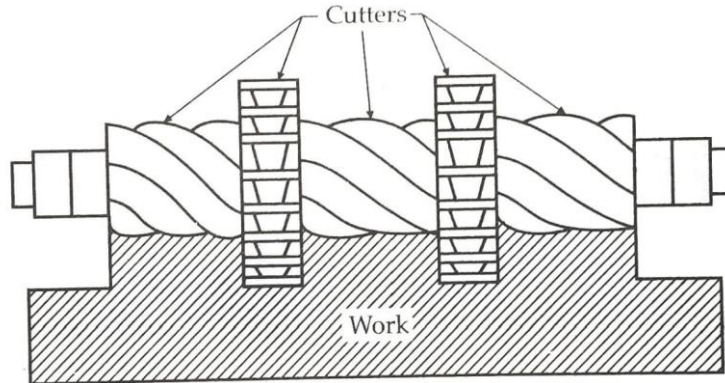

Gang milling

Apart from this, a number of other operations are named either after the name of the cutter used for them or some other factors like the shape or use of the surface produced. These operations are, however, the variations of these standard operations only and may involve one or a combination of more than one of the above operations. These operations are :

- Slot and Groove Milling
- Keyway Milling
- Slitting or Saw Milling
- Side Milling
- End Milling
- Gear Milling
- Cam Milling
- Thread Milling
- Helical Milling

SLOT AND GROOVE MILLING

Slot Milling is the operation of producing slots in solid work pieces on a Milling machine. These slots can be of varied shapes, such as s Plain slots, T-slots, Dovetail slots, etc. Similarly, Groove Milling is the operation of producing Grooves of different shapes, such as Plain grooves, Curved grooves, V-grooves, etc.

The cutter to-be used is chosen according to the shape of the groove or slot to be produced Milling of a V-groove, using a Double Angle Cutter has already been shown under angular milling.

Similarly, Plain Grooves or Slots can be milled by means of a Plain Milling Cutter, an End mill, a Slitting saw or a Side milling cutter as shown in figure.

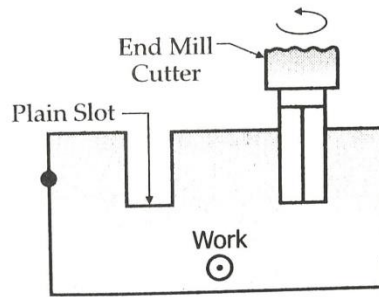

Milling of T-slot and Dovetail slot is carried out in two or three stages. In the first stage an open slot, from one end of the solid workpiece to its other end, is first milled with the help of a suitable cutter, say a Plain Milling Cutter or an End Mill. Then the slot is milled to the required shape by using a special cutter a T-slot Cutter for T-slot and a Dovetail Milling Cutter for Dovetail slots. The operation of finish milling a T-slot is shown in Fig.

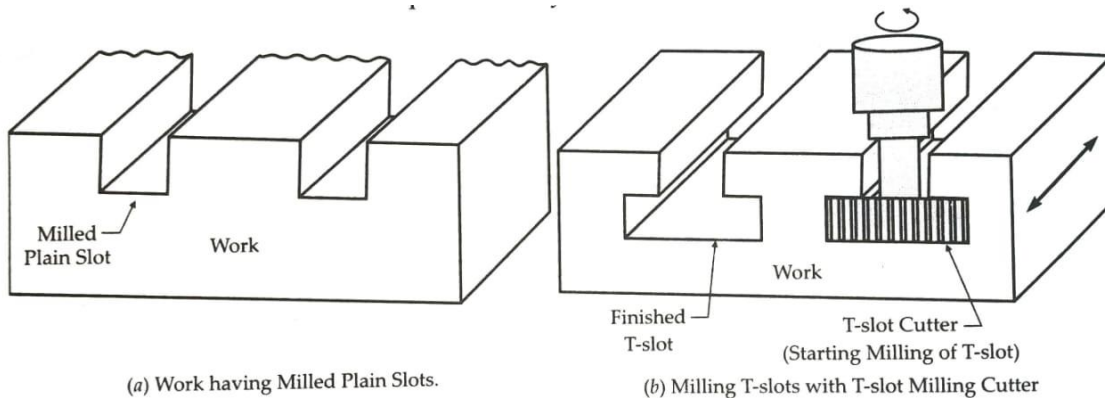

Production of a Dovetail slot in three stages is shown in Fig.

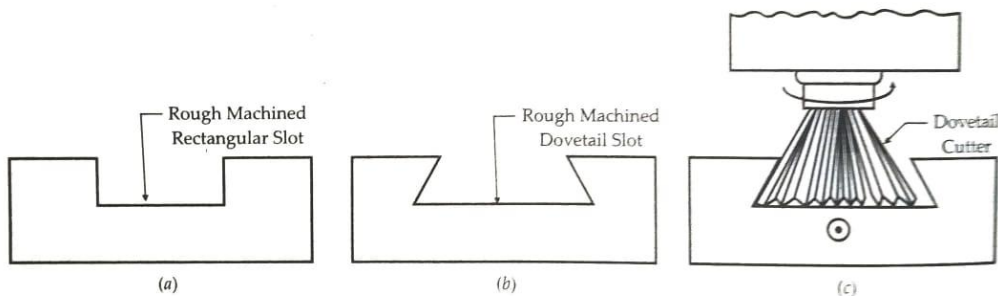

11.71 Milling a Dovetail Slot. (a) Rough machined rectangular slot (b) Rough machined Dovetail Slot (c) Finish machining the Dovetail Slot with the help of a Dovetail Milling Cutter.

At (a) is shown a rectangular slot produced through rough machining by means of a Plain Milling Cutter. The required angles of the dovetail are then rough machined by means of a Form Angle Cutter and a rough machined Dovetail slot obtained, as shown at Fig. (b). The slot is finally finished by machining the base and sides of the slot with the help of a Dovetail Milling Cutter.

SIDE MILLING

In this operation, a Side Milling Cutter is used to machine a flat vertical surface on a side of the workpiece. When two parallel vertical flat surfaces are required to be machined, the usual time saving practice is to use a pair of two Side Milling Cutters to machine both the surfaces simultaneously. The space between the two cutters can be easily adjusted as per requirement by using the Spacers. This operation is then known as 'Straddle Milling' and is already explained earlier.

END MILLING

In this operation, an End Mill Cutter is used to machine and produce a flat surface or a pair of parallel flat surfaces. When the operation is performed at the end of a workpiece, as shown in Fig. a single flat surface is produced. The surfaces produced may be horizontal, vertical or inclined with respect to the top of the machine table.

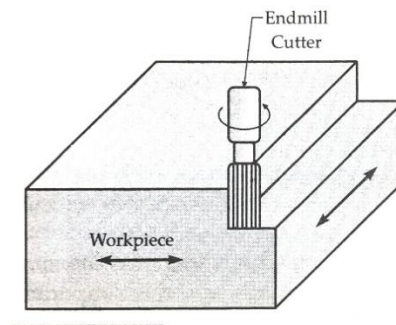

End milling

WORK HOLDING ATTACHMENTS

VICES

Vices are the common devices used for holding the work on Milling Machines. The common types of the Vices used are the following:

- A. Plain or Parallel Vice
- B. Swivel Vice
- C. Universal Swivel Vice
- D. Vertical Vice
- E. Precision Angle Vice
- F. Compound Vice

1. Plain Machine Vice

Shown in Fig, it is most widely used form of all the above six. It consists of a solid cast Base, carrying a Fixed Jaw at one end and the Movable jaw at the other.

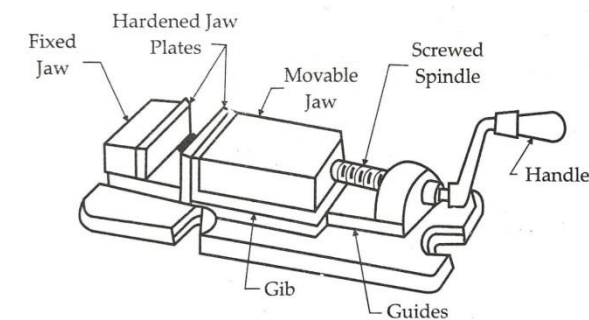

It is commonly employed for holding the work in all Plain milling operations, which involve heavy cuts, such as in Slab milling. Its construction enables the work to remain quite close to the table and, thus, reduces the chances of vibrations to a minimum. The base carries slots to accommodate T-bolts to fix the vice on the Table.

2. The Swivel Vice

It consists of a Swivel Base, on which the Body is mounted. The body can be clamped in any angular position by means of the Clamping bolts. The Graduated plate provided on the swivel

base helps in adjusting the body at any desired angle relative to the base. The upper construction is similar to that a Plain vice.

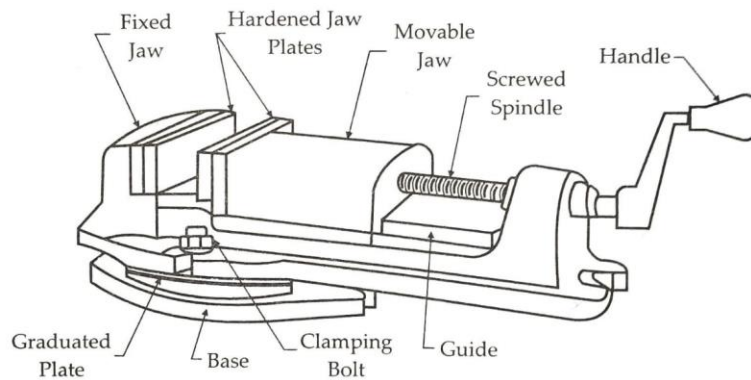

A typical design of this type is shown in Fig. This Vice facilitates milling of an angular surface on the work piece without distributing its setting.

3. The Universal Machine Vice

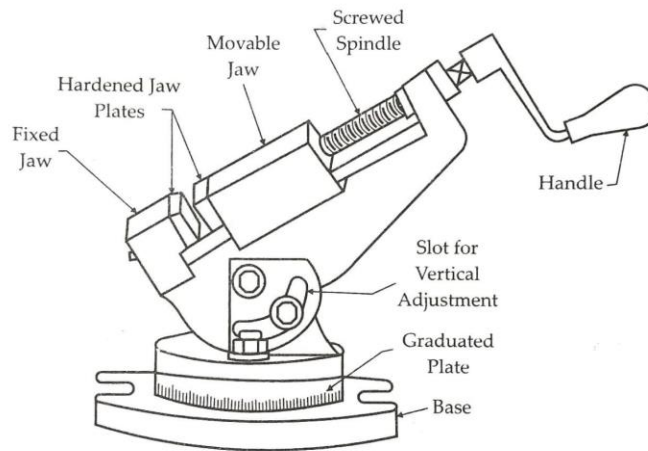

Shown in Fig, it enables milling of various surfaces, at an inclination to one another, without removing the work piece from the vice. The Vice, apart from being swivelled in a horizontal plane, can also be tilted vertically to be set at a desired angle. It is vastly used in Tool room work and should not be used where heavy cuts are to be employed since it does not have the required Clamping rigidity.

4. The Vertical Vice

It very much resembles a Plain Vice in construction and operation both. The only difference is that-it carries vertical jaws instead of the horizontal jaws. Its specific use is in holding those jobs on which milling is to be done at the ends. .

5. The Precision Angle Vice

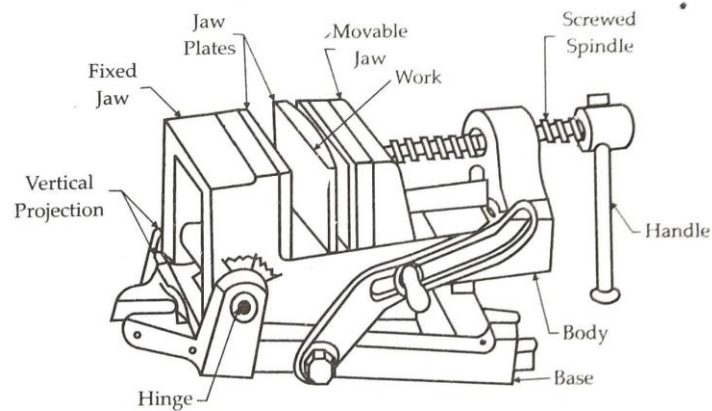

It consists of a cast Base, carrying two small vertical projections. One end of the Body is hinged about these projections and the other end can be adjusted in a vertical direction, It, thus, enables a precision angular adjustment of the job in a vertical plane.

6. The Compound Machine Vice

Shown in Fig, it is a very important and precision vice, which carries a Compound Slide similar to the one used on a Centre lathe.

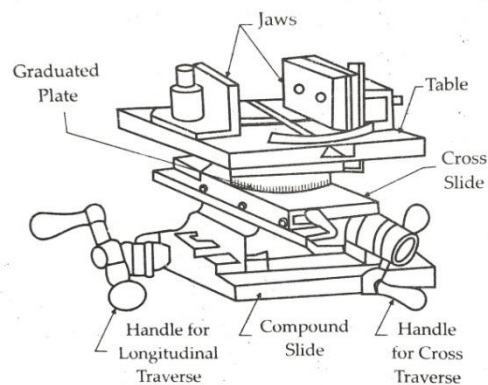

The Work piece is held on the table provided at the top of the Vice. This table can be swivelled in a horizontal plane to any desired angle, thus eliminating the use of a Swivel vice. The Compound slide enables the adjustment of the work from front to back, back to front, left to right and right to left. Thus, the work can be adjusted in any desired position.

CIRCULAR TABLE OR ROTARY MILLING TABLE

It is also called the Circular Milling Attachment and is employed for indexing as well as providing continuous rotary motion to the work. It can be either manually operated or power driven.

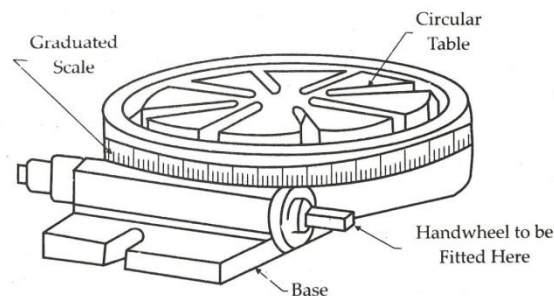

It consists of a heavy Base, which is secured to the machine Table by means of T-bolts. Rotary motion to the table is provided by rotating the Hand wheel, which operates the Worm wheel to the bottom of the circular table, through a Worm provided on the shaft on which this Hand wheel is mounted. The work piece can be mounted on the Table either directly by means of clamps and bolts or held in a Vice clamped to the table. Alternatively, a specially designed Milling Fixtures can be used to hold the work.

CLAMPS

Many Jobs, on account of their shape, size and weight, etc., cannot be conveniently held in Vices. Such components are directly secured to the machine table by means of Clamps, Straps, Jacks, Step blocks and clamping bolt etc. The common types of straps, clamps, blocks and clamping bolt are shown in Fig. All these Straps and Clamps carry a long hole, through which passes the clamping bolt.

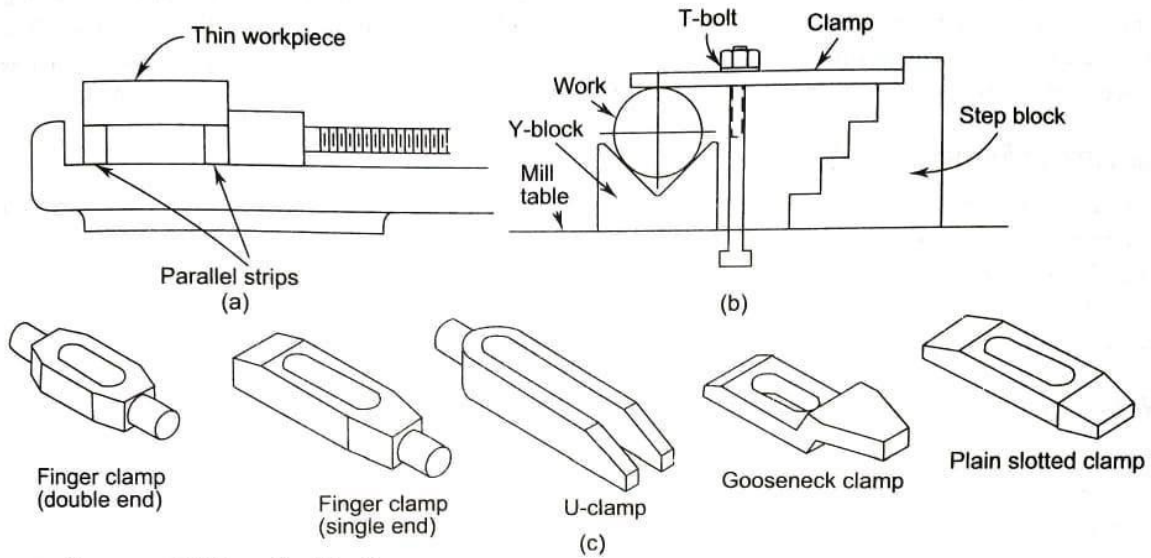

Fig. Common work-holding methods in milling

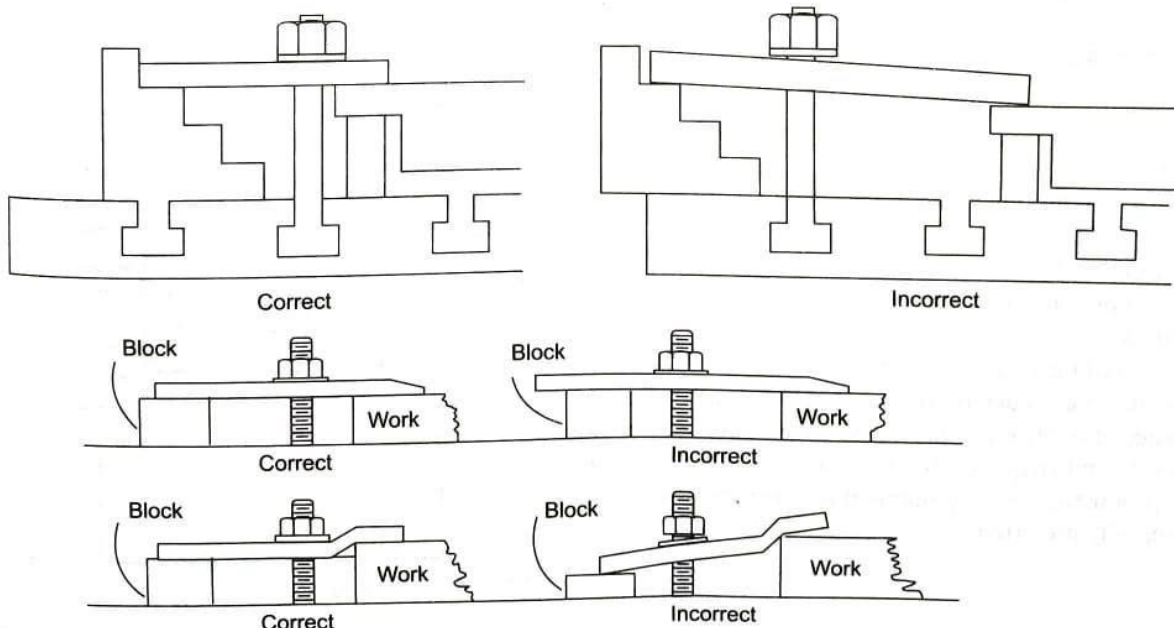

Fig. Work-holding principles in milling

ANGLE PLATES AND V-BLOCKS

Occasionally it may be required to mill the surfaces of a work piece at right angles. This operation can be very conveniently performed by holding the work piece on an Angle plate, which is secured to the machine table.

For this, the Angle plate should be fastened to the table in such a position that it is either parallel to or square with the machine spindle. Its alignment should be thoroughly checked before

mounting the work on it. Strap Clamps or C-clamps should be used to hold the work on the Angle plate.



Solid cylindrical work which is not centred, such as a Shaft, can be held in V-blocks for milling Keyways, Slots and Flats, etc., on it. The V-blocks used on milling machine are usually provided with a flange or projected tongue at their bottom for clamping them to the machine table, as shown in Fig. Usually two or more V-blocks are used simultaneously to support the work, depending upon the latter's length. The work is firmly held in position by means of the Strap clamps and Blocks.

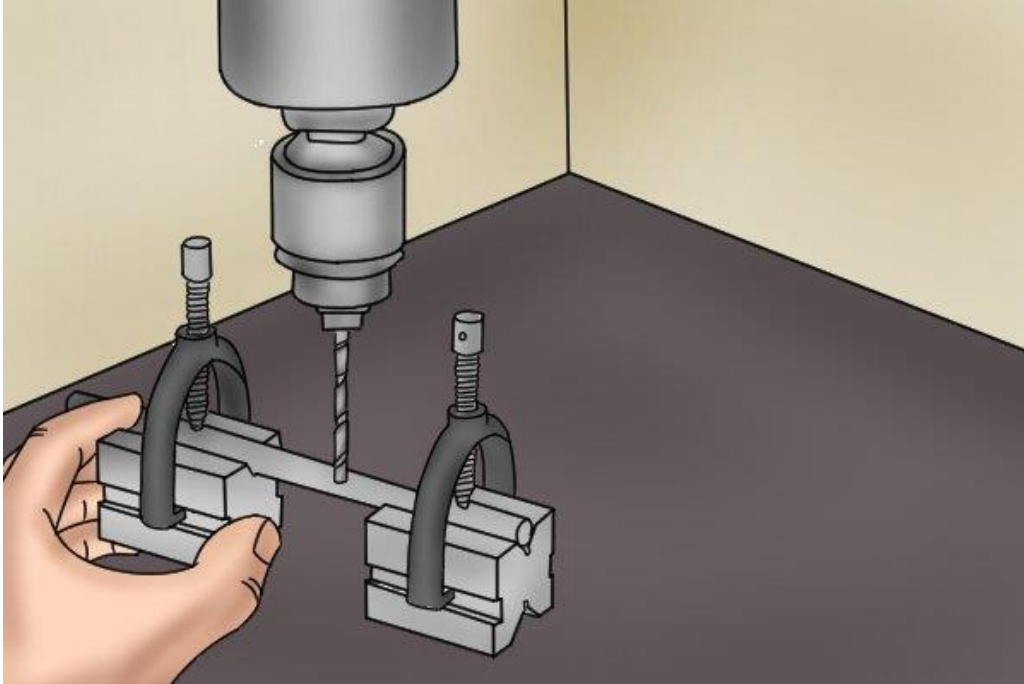

INDEXING OR DIVIDING HEADS

The heads help in changing angular position of the component in relation to the cutter. With their use it is possible to divide the periphery of the workpiece into any number of equal parts.

1. Plain Dividing Heads

These Dividing Head carries the Indexing Plate directly mounted on its Spindle and has no use of the worm, and worm wheel. It is the simplest of all the dividing heads and is used in Direct Indexing. The Index Plate carries 12 or 24 equispaced Slots on its periphery. Figure shows such a Dividing head. The job is held between two centres, one on the Dividing head Spindle and the other on the Tailstock.

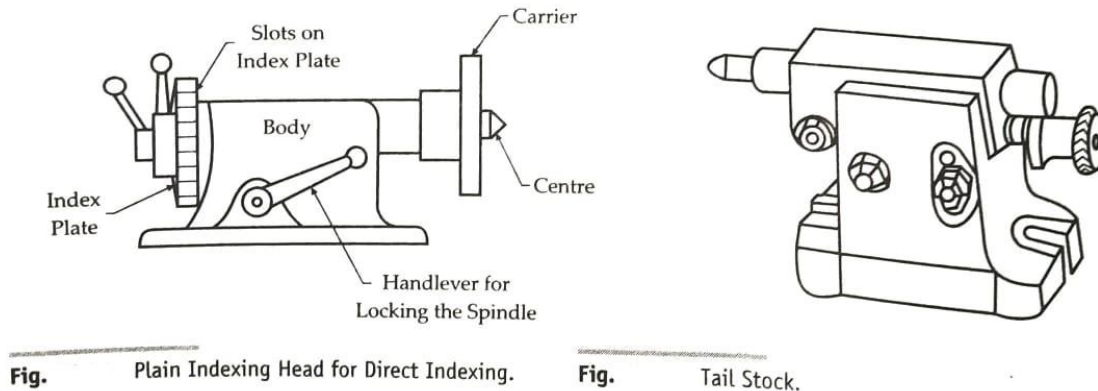

The Hand lever is used for locking the spindle in position. In operation, a lug engages the desired slot of the Indexing plate. By means of this Dividing heads 2, 3, 4, 8, 12 and 24 division obtained when 24 Slots Plate is used and 2, 3, 4, 6 and 12 divisions when a 12 Slots plate is used. The Plate, together with the spindle, can be rotated by means of the Handle provided on the left side of the Dividing head.

2. Universal Dividing Heads

The typical construction of the dividing head is shown in Fig. The main spindle of the dividing head drives the workpiece by means of a 3-jaw universal chuck or a dog and live-centre similar to a lathe.

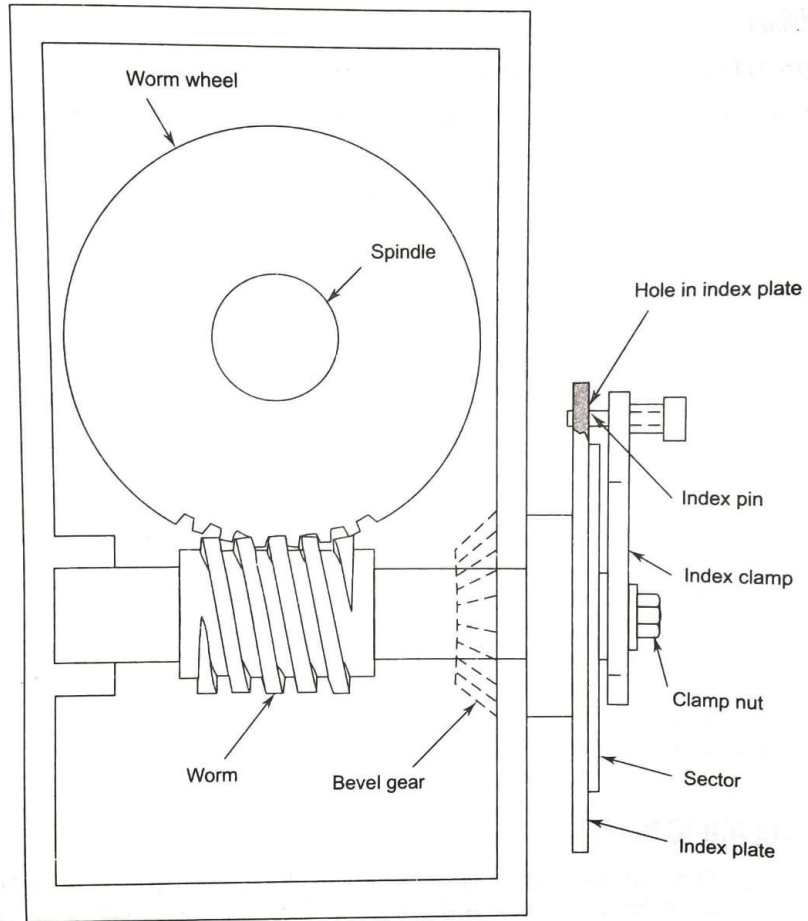

Dividing-head construction

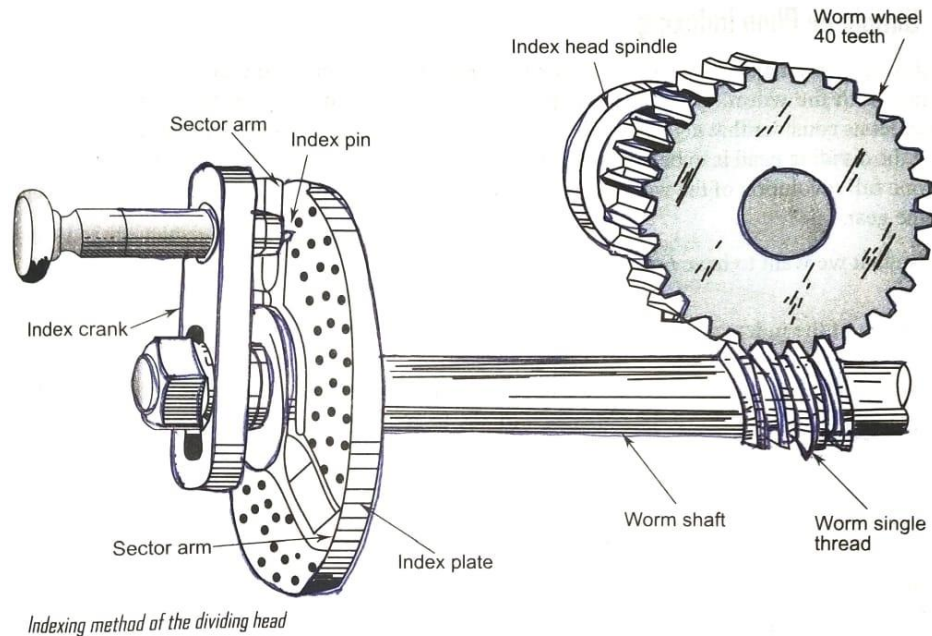

The index plate of a dividing head consists of a number of holes with a crank and pin. The index crank drives the spindle and the live centre through a worm gear, which generally has 40 teeth as shown in Fig. As a result, a full rotation of the workpiece is produced by 40 full revolutions of the index crank. Further indexing is made possible by having the index plates with equi-spaced holes around various circles. This would allow for indexing the periphery of the workpiece to any convenient number of divisions.

The index plates available with the Brown and Sharpe milling machines are

Plate no. 1: 15, 16, 17, 18, 19, and 20 holes

Plate no. 2: 21, 23, 27, 29, 31, and 33 holes

Plate no. 3: 37, 39, 41, 43, 47, and 49 holes

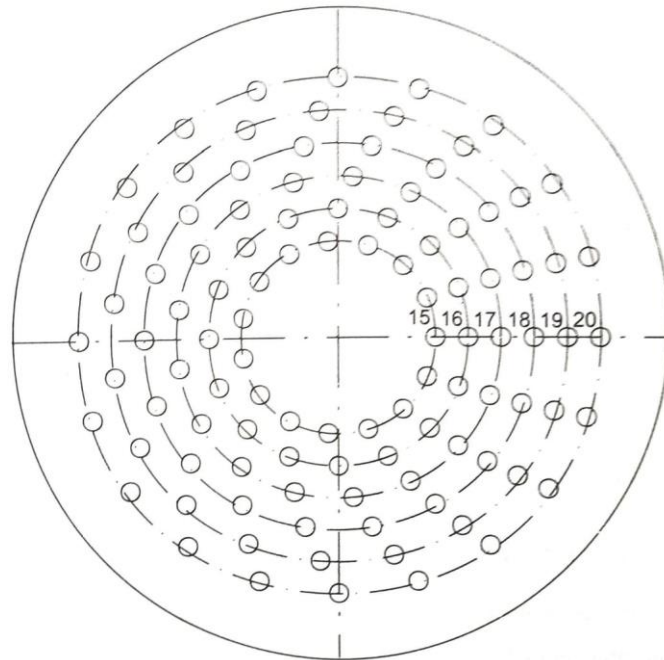

Index plate no. 1 of Brown and Sharpe dividing head

The index plate used on Cincinnati and Parkinson dividing heads is

Plate 1:

Side 1: 24, 25, 28, 30, 34, 37, 38, 39, 41, 42 and 43 holes

Side 2: 46, 47, 49, 51, 53, 57, 58, 59, 62 and 66 holes

It is also possible to get additional plates from Cincinnati to increase the indexing capability as follows:

Plate 2:

Side 1: 34, 46, 79, 93, 109, 123, 139, 153, 167, 181, and 197 holes

Side 2: 32, 44, 77, 89, 107, 121, 137, 151, 163, 179, and 193 holes

Plate 3:

Side 1: 26, 42, 73, 87, 103, 119, 133, 149, 161, 175, and 191 holes

Side 2: 28, 38, 71, 83, 101, 113, 131, 143, 159, 173, and 187 holes

As described above, the Dividing Head provides support to the job, holds it in position and rotates it through a desired angle after each cut is over.

The Index crank is rotated to provide the rotary motion to the job and the Index plate enables this rotation to take place always through a desired angle. When the Crank is rotated, the worm rotates which, in turn, rotates the worm wheel. Since this wheel is mounted directly on the spindle the latter rotates along with for former.

The job, being secured to the spindle by means of a suitable holding device, also rotates as the spindle rotates. The angle through which the job will rotate, for each revolution of the crank, depends upon the Velocity ratio between the worm and worm-wheel. This ratio is usually 40 to 1, i.e., for 40 revolutions of the worm, or of the Crank, the job will make one revolution. Obviously, if the Worm is single start the Worm wheel will have 40 teeth along its periphery. However, some Dividing Heads carry a different velocity ratio of these two and the same should be known before performing the actual Indexing operation.

INDEXING METHODS

By Indexing we mean division of the job periphery into a desired number of equal divisions. It is accomplished by a controlled movement of the Crank such that the Job rotates through a definite angle after each cut is over. The following methods of Indexing are commonly used:

- ✚ Direct-indexing
- ✚ Plain or Simple Indexing
- ✚ Compound Indexing
- ✚ Differential Indexing
- ✚ Angular Indexing

Direct indexing

It is the simplest case of Indexing in which a Plain Dividing Head is used. As indicated there, the Index plate is directly mounted on the spindle and rotated by hand. It can be used only when the number of divisions to be obtained on workpiece is such that the number of slots on the periphery of the Index plate is a multiple of the former.

The Indexing ratio is obtained by:

Required ratio = N/n

N = No. of slots on the periphery of the index plate

n = No. of divisions required to be obtained on workpiece.

For example, if the circumference of a job has to be divided into 6 equal divisions and the Index plate has 24 slots, then the required ratio will be:

$$= 24/6 = 4/1$$

i.e., the index plate will be required to move through 4 slots after each cut is over.

Plain or Simple Indexing

This method of Indexing is used when the direct method of indexing cannot be employed for obtaining the required number of divisions on the work. For example, if the work is required to be divided into 22 equal divisions the Direct Indexing cannot be used, because 22 is not divisible into any of the hole circles on the Direct Indexing Plate. For such cases, Simple Indexing can easily be used.

For this, a Universal Dividing Head can be used. This method of indexing involves the use of the crank, worm, wormwheel and Index plate. As already described, the Worm wheel carries 40 teeth and Worm is single start. The worm wheel is directly mounted on the spindle.

When the Crank pin is pulled outwards and the Crank is rotated, the worm will rotate which, in turn, will rotate the worm wheel, and hence the spindle and the work.

Since the Worm has single start thread and the Worm wheel 40 teeth, with one turn of the crank (i.e., of the worm) the worm wheel will rotate through one pitch distance, i.e., equal to $1/40$ of a revolution. Similarly 2 turns of crank will make the work to rotate through $1/20$ and 3 turns through $3/40$ of a revolution. Thus, the Crank will have to be rotated through 40 turns in order to rotate the work through one complete turn.

The holes in the Index plate serve to subdivide the rotation of the Index crank.

Now suppose we want to divide the work into a number of divisions, the corresponding Crank movements will be as given:

For two divisions on the Work, the Crank will make $40/2 = 20$ turns for each division

For four divisions on the Work, the Crank will make $40/4 = 10$ turns

For ten divisions on the Work, the Crank will make $40/10 = 4$ turns

Similarly for n divisions on the Work, the Crank will make $40/n$ turns.

Suppose that we want to have 6 equal divisions to be made.

The rotation of the index crank = $40/6 = 6\frac{2}{3}$ turns

This means that the index crank should be rotated 6 full turns followed by two thirds of a rotation. The fraction of a rotation required is to be obtained with the help of the index plates as given above. This can done as follows using any of the Brown and Sharpe plates.

Plate no. 1: 10 holes in a 15-hole circle

12 holes in an 18-hole circle

Plate no.2: 14 holes in a 21-hole circle

18 holes in a 27-hole circle

22 holes in a 33-hole circle

Plate no.3: 26 holes in a 39-hole circle

EXAMPLE (1) Indexing 28 divisions.

Solution The rotation of the index crank = $\frac{40}{28} = 1\frac{3}{7}$ turns.

This can be done as follows using any of the Brown and Sharpe plates.

One full rotation + 9 holes in a 21-hole circle in Plate no. 2.

One full rotation + 21 holes in a 49-hole circle in Plate no. 3.

EXAMPLE (2) Indexing 62 divisions.

Solution The rotation of the index crank = $\frac{40}{62} = \frac{20}{31}$ turns.

This can be done as follows using any of the Brown and Sharpe plates.

20 holes in a 31-hole circle in Plate no. 2.

Compound Indexing

This method of Indexing is employed when the number of divisions required is outside the range that can be obtained by Simple Indexing. It involves the use of two separate simple indexing movements and is performed in two stages:

1. By turning the Crank a definite amount in one direction in the same way as in Simple indexing.
2. By turning the Index plate and the Crank both, either in the same or reverse direction, thus adding further movement to or subtracting from that obtained in the first stage.

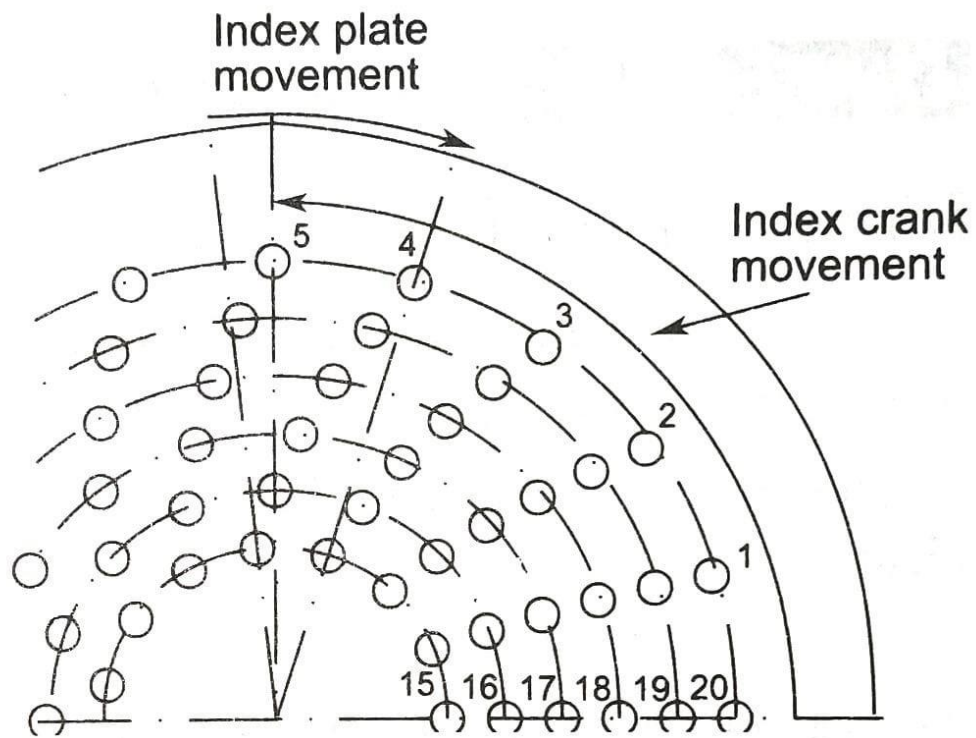

Fig. *Compound indexing using the index plate no. 1 of Brown and Sharpe dividing head with 5 holes in the 20-hole circle minus 1 hole in the 15-hole circle*

For example, if the indexing is done by moving the crank by 5 holes in the 20-hole circle then the index plate together with the crank is indexed back by a hole with the locking plunger registering in a 15 hole circle as shown in Fig.

The total indexing done is then

$$\frac{5}{20} - \frac{1}{15} = \frac{11}{60}$$

i.e. 11 holes in a 60-hole circle. Unfortunately, the 60-hole circle is not available in the Brown and Sharpe range of index plates. Similarly, it is possible to have the two motions in the same direction as well. In that case, the total indexing will be

$$\frac{5}{20} + \frac{1}{15} = \frac{19}{60}$$

i.e. 19 holes in a 60-hole circle.

SLOTING MACHINE

Slotting machine is basically a vertical-axis shaper with some differences. This is a larger version of the vertical shaper with ram strokes up to 1800 mm long. Thus the workpieces, which cannot be conveniently held in shaper, can be machined in a slotter. Generally, keyways, splines, serrations, rectangular grooves and similar shapes are machined in a slotting machine.

Vertical Shaper

It is similar to a mechanical shaper except that the reciprocating axis here is vertical. This is similar to a slotter in action and often used interchangeably. The vertical shaper is a much smaller version of the slotter, and was developed for toolroom work. The stroke of the ram is generally limited below 300 mm.

The main difference between the two is that while the slotter only allows for vertical motion, the vertical shaper has the ability to adjust the ram in the vertical position about 15° from the vertical. This will help in cutting of proper clearances in tools and dies.

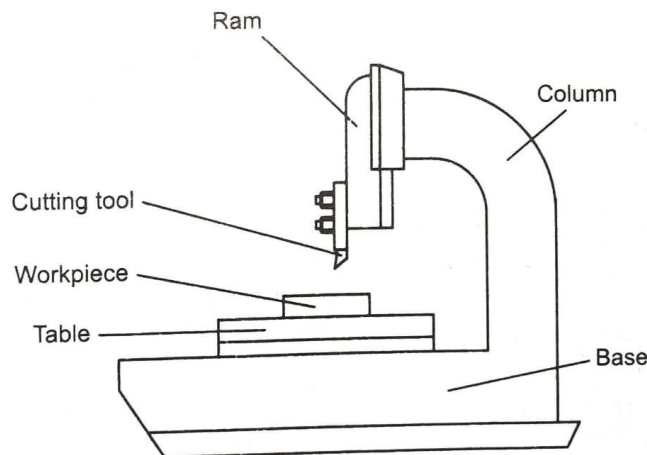

Schematic of a typical slotting machine

Main parts of a slotter:

1. **Base:** It is a heavy Cast iron construction and is also known as Bed. It acts as support for the Column, the Driving mechanism Ram, Table and all other Fittings. At its top it carries horizontal ways, along which the table can be traversed.
2. **Column:** It is another heavy Cast iron Body which acts as a housing for the complete driving mechanism. At its front it carries vertical ways, along which the Ram moves up and down.

3. **Table:** Usually a Circular Table is provided on Slotting machines. In some heavy duty Slotters, such as a Puncher Slotter, either a rectangular or circular Table can be mounted. On the top of the Table are provided T-slots to clamp the work or facilitate the use of fixtures, etc.
4. **Ram:** It moves in a vertical direction between the vertical guideways provided in front of the Column. At its bottom, it carries the Tool post in which the Tool is held. The cutting action takes place during the downward movement of the Ram.

TYPES OF DRIVES

Mainly three types of driving mechanisms are used in Slotting machines for driving the Ram.

- Slotted disc mechanism
- Slotted link and gear mechanism, and
- Hydraulic mechanism

The Slotted Disc Mechanism

It is the simplest of all the methods commonly used for driving the Ram of a Slotting machine. The driving mechanism consists of a Pinion, a Gear, a Slotted disc and Crank. The disc carries a T-slot through which passes the Crank pin (See Fig.). Its distance from the centre of the disc can be adjusted as desired.

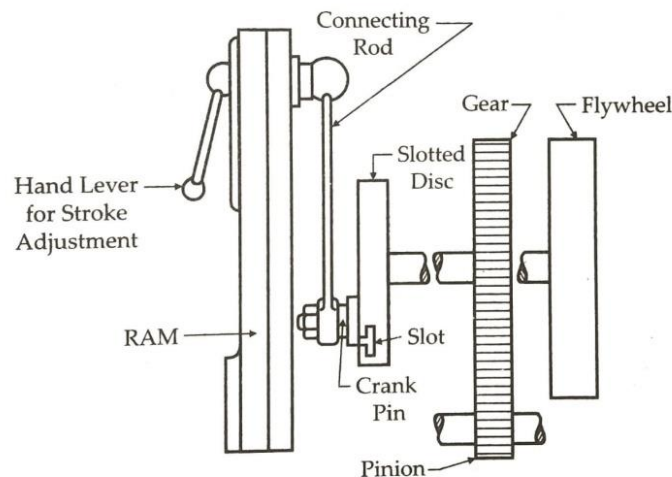

The main Driving pulley, generally situated at the rear side of the machine, is driven by the Motor through Belts. It, in turn, drives the Pinion which drives the Gear. The gear being on the same shaft as the disc drives the latter. The Crank and Connecting rod mechanism converts the circular motion of the disc into reciprocating motion of the ram. The length of stroke of the ram can be varied by shifting the crank pin towards or away from the centre of the disc. The starting and finishing positions of the ram stroke can be adjusted by means of the Hand lever for stroke

adjustment. The Flywheel, provided at the rear side, acts as a shock absorber at the end of the stroke.

TYPES OF SLOTTING MACHINE

1. **Puncher slotters**
2. **Production slotters**
3. **Tool room slotters**

Puncher Slotters

Puncher Slotters are heavy duty machines. Usually such jobs are machined on these machines which are comparatively heavier and have been previously brought roughly to the required shape through other operations like Sawing, Forging or Stamping etc. The Slotting machine is then used to cut off the surplus metal and finish the work to the required shape and size. According to the nature of the work, either a square or circular Table can be fitted on the machine.

Production Slotters

This is the common category of Slotters, vastly used for general production work. It consists of heavy Cast Base and a heavy Frame, made usually in two parts.

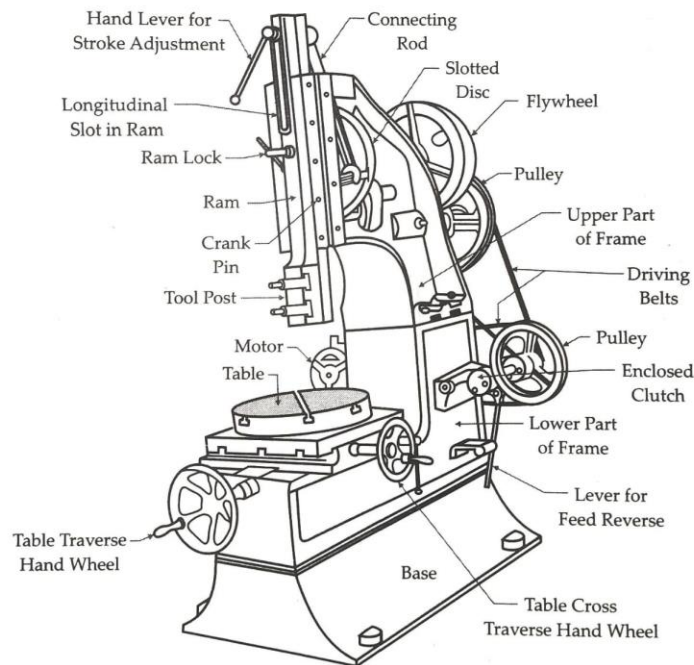

- The upper part may be of stationary type or tilting type.
- In tilting type of frames a Worm and Worm wheel are provided at the rear side to enable the said tilting of the frame. The tilting type of frame enables machining of tapered

surfaces, in addition to the normal machining operations performed with a stationary type of frame.

- A typical Production Slotter with fixed type frame is shown in Fig. The drive of the ram is accomplished by means of the Slotted disc and Connecting rod, as explained earlier. The Flywheel is fitted to prevent shock at the end of the stroke.
- The lower part of the frame is provided with horizontal ways. On this, is fitted the Cross slide, which can be given a transverse motion by means of Handwheel. The Table is mounted on the cross slide and can be given a cross motion by means of a Handwheel. In addition to this, the Table carries teeth along its periphery and can be rotated by means of a worm meshing with these teeth.

Tool Room Slotters

- These Slotting machines are of precision type and are used for very accurate machining.
- Usually tilting type of frame is provided in these machines to enable machining at different angles.
- Slotted link type drive is commonly used in these machines. Rest of the construction is similar to that of a Production Slotter.

SLOTTER TOOLS

Slotter Tools are either forged from solid bar of tool steel or are used in the form of bits held in suitable Tool holders. In either case, the tools are made of enough stiff section.

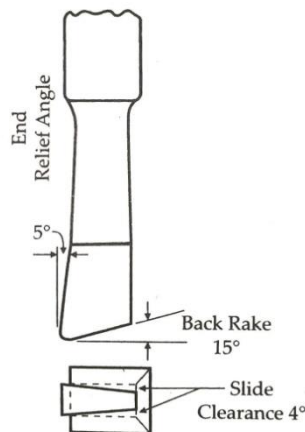

Since the cutting takes place parallel to the shank length, no side rake is provided on Slotter tools. The Back rake is provided at the end. A typical slotter tool for internal machining is shown in Fig. Shape of the cutting end of the tool is made according to the shape of the slot to be produced. The same speeds and feeds are used on Slotting machines as on Shapers.

GRINDING

- Grinding is a process of removing material by the abrasive action of a revolving wheel on the surface of a workpiece, in order to bring it to the required shape and size.
- So far as the cutting action is concerned, grinding is very much similar to the other machining operations since the microscopic examination of the removed material reveals that the same is in the form of small chips, similar to those obtained in other machining operations.
- The wheel used for performing the grinding operation is known as 'Grinding Wheel'. It consists of sharp crystals, called abrasives, held together by a binding material or bond. The wheel may be a single piece or solid type or may be composed of several segments of abrasive blocks joined together. In most cases, it is a finishing operation and a very small amount of material is removed from the surface during the operation.

COMMON FORMS OF ABRASIVE TOOLS

The following four types of abrasive tools are in common use :

- > Stones and sticks
- > Coated abrasives
- > Polishing grains
- > Grinding wheels

THE GRINDING WHEEL

A grinding wheel is a multitooth cutter made up of many hard particles known as abrasive which have been crushed to leave sharp edges which do the cutting. The abrasive grains are mixed with a suitable bond, which acts as a matrix or holder when the wheel is in use. The wheel may consist of One piece or of segments of abrasive blocks built up into a solid wheel. The abrasive wheel is usually mounted on some form of machine adapted to a particular type of work.

ABRASIVES

An abrasive is a substance that is used for grinding and polishing Operations. It should be pure and have uniform physical properties of hardness, toughness, and resistance to fracture to be useful in manufacturing grinding wheels.

Abrasives may be classified in two principal groups :

1. Natural. 2. Artificial or manufactured.

1. **Natural:** The natural abrasives include sandstone or solid quartz, emery, corundum, and diamonds.

- Sandstone or solid quartz is one of the natural abrasive stones from which grindstones are shaped.
- Emery is a natural aluminium oxide. It contains from 55 to 65 per cent alumina, the remainder consist of iron oxide and other impurities.
- Corundum is a natural aluminium oxide also. It contains from 75 to 95 cent aluminium oxide; the remainder consists of impurities. Both emery and corundum have a greater hardness and better abrasive action than quartz.
- Diamonds of less than gem quality are crushed to produce abrasive grains for making grinding wheels to grind cemented carbide tools and to make lapping compound. As a result of the impurities in and lack of uniformity of these natural abrasives, only a very a small percentage of grinding wheels are produced from natural abrasives.

2. **Artificial:** Artificial or manufactured abrasives include chiefly (a) silicon carbide, and (b) aluminium oxide.

Silicon carbide (SiC) abrasive is manufactured from 56 parts of silicon sand, 34 parts of powdered coke, 2 parts of salt, and 12 parts of saw dust in a long, rectangular electric furnace of the resistance type that is built up of loose brickwork. Sand furnishes silicon, coke furnishes carbon, sawdust makes the charge porous, salt vaporizes to form chlorides with the metallic impurities present and thus helps in removing them, and gases may escape through the open joints in the brickwork. The abrasive wheels are denoted by 'S'.

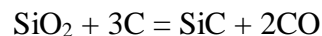

There are two types of silicon carbide abrasives : green grit which contains at least 97 per cent silicon carbide, and black grit which contains at least 95 per cent silicon carbide. This form is harder but weaker than the latter.

Silicon carbide follows the diamond in order of hardness, but it is not as tough as aluminium oxide.

It is used for grinding materials of low tensile strength such as cemented carbides, stone and ceramic materials, gray cast iron, brass, bronze, copper, aluminium, vulcanized rubber, etc. The names of the manufacturers, manufacturing silicon carbide grinding wheels and the trade names are given below :

Manufacturer	Trade name
The carborundum Co	carborundam
The Norton company	crystolon
Macklin company	silicon carbide
Abrasive company	electrolon

Aluminium oxide (Al_2O_3) manufactured by heating mineral bauxite, a hydrated aluminium oxide clay containing silica, iron oxide, titaniumoxide, etc., mixed with ground coke and iron borings in a arc-type electric furnace.

Aluminium oxide is tough and not easily fractured, so it is better adopted to grinding materials of high tensile strength, such as most steels, carbon steels, high speed steels, annealed malleable iron, wrought iron, tough bronzes. The wheels are denoted by 'A'. The names of manufacturers and their trade names are given below:

Manufacturer Tradename Manufacturer Trade same

The Carborundum Co Alomite Macklin Company Aluminium oxide

The Norton Company Alundum Abrasive Company Borolon

BONDS AND BONDING PROCESSES

A bond is an adhesive substance that is employed to hold abrasive grains together in the form of sharpening stones or grinding wheels. Bonding materials and processes are :

1. Vitrified bond used for making verified grinding wheels.
2. Silicate bond for making silicate wheels.
3. Shellac bond for making elastic wheels.
4. Resinoid bond used for making resinoid wheels.
5. Rubber bond used for making vulcanized wheels.
6. Oxychloride bond for making oxychloride wheels.

These bonds may be used with either silicon carbide or aluminium oxide.

Vitrified bonding process : Verified wheels are made by bonding clay melted to a glass like consistency with abrasive grains. The clay and abrasive grains are thoroughly mixed together with sufficient water to make the mixture uniform. The fluid mixture is then poured into

mouldsand allowed to dry. When it has dried to a point where it can be handled, the material is cut trimmed to more perfect size and shape. It is then heated or burned in a kiln in much the same manner as brick or tile is burnt. When the burning proceeds, the clay vitrifies ; that is, it fuses and forms a porcelain, or glasslike substance that surrounds and connects the abrasive grains. The high temperature employed in this process tends to anneal the abrasives to some extent.

Vitrified bond gives a wheel good strength as well as porosity to allow high stock removal with cool cutting. It is affected by heat, coldwater or acids. Disadvantages of vitrified bonded wheels are their sensitivity to impact and their low bending strength. About 75 per cent of the wheels now manufactured are made with this bond. A vitrified bonded wheel is denoted by the letter 'V'.

Silicate bonding process : Silicate wheels are made by mixing abrasive grains with silicate of soda or water glass. The mixture is packed into moulds and allowed to dry. The moulded shapes are then backed in a furnace at a temperature of 260°C for several days.

The silicate bond releases the abrasive grains more readily than the vitrified bond, the abrasive grains are not annealed as in the vitrified process, and silicate wheels are waterproof. These characteristics make silicate wheels valuable for grinding edged tools and other operations where heat must be held to a minimum with or without the aid of a coolant. A silicate bonded wheel is denoted by the letter 'S'.

Shellac bonding process : Shellac bonded wheels are also known as elastic bonded wheels. In this process, the abrasive and shellac are mixed in heated containers and then rolled or pressed in heated moulds. Later the shapes are backed a few hours at a temperature of approximately 150C.

The elasticity of this bond is greater than in other types and it has considerable strength. It is not intended for heavy duty. Shellac bond is cool cutting on hardened steel and thin sections, and is used for finishing chilled iron, cast iron and steel rolls, hardened steel cams and aluminum pistons, and in very thin sections, for abrasive cutting of machines. A shellac bonded wheel is denoted by the letter 'E'.

Resinoid bonding process: Resinoid wheels are produced by mixing abrasive grains with synthetic resins and other compounds. The mixture is placed in moulds and heated at about 200. At this temperature, the resin sets to hold the abrasive grains in wheel form.

Wheels bonded with synthetic resin, such as Bakelite and Redmanol, are used for purposes which require a strong, free high speed wheel. They can remove stock very rapidly. They are useful for precision grinding cams, and rolls requiring high finish. A resinoid bonded wheel is denoted by the letter B'.

Rubber bonding process : Rubber bonded wheels are prepared by mixing abrasive grains with pure rubber and sulphur. The mixture rolled into sheets, and wheels are punched out of the sheets on a punch press. Following that, the wheels are vulcanized.

Rubber bonded wheels are more resilient, less heat resistant. and more dense than resinoid bonded wheels. They are used where good finish is primary requisite. They are strong and tough enough to make extremely thin wheels. A rubber bonded wheel is denoted by the letter R’.

Oxychloride bonding process : This process consists of mixing abrasive grains with oxide and chloride of magnesium. The mixing of bond and abrasive is performed in the same way as for vitrified bonded wheel.

Oxychloride bonds are employed in making wheels and wheels segments for use in disc-grinding operations. The bond ensures a cool cutting action. So grinding is best done dry. An oxychloride bonded wheel is denoted by the letter ‘O’.

GRIT, GRADE AND STRUCTURE OF WHEELS

GRITS:

The grain or grit number indicates in a general way the size of the abrasive grains used in making a wheel, or the size of the cutting teeth, since grinding is a true cutting operation. Grain size is denoted by a number indicating the number of meshes per linear inch (25.4 mm) of the screen through which the grains pass when they are graded after crushing. The following list ranging from very coarse to very fine, includes all the ordinary grain sizes commonly used in the manufacture of grinding wheels:

COMMAN ABRASIVE GRAIN TYPE AND SIZE

	Grain size or grit						
Coarse	10	12	14	16	20	24	
Medium	30	36	46	54	60		
Fine	80	100	120	150	180		
Very fine	220	240	280	320	400	500	600

In case grinding whcels are manufactured from special grain combinations, the grinding wheel manufacturer may use an additional symbol appended to the standard grain size number.

Example: 36- Normal standard.

36.5- Special grain combination.

The size of abrasive grain required in a grinding wheel depends on the amount of material to be removed, the finish desired, and the hardness of the material being ground.

In general, coarse wheels are used for fast removal of materials. Fine grained wheels are used for soft, ductile materials but generally a fine grain should be used to grind hard, brittle materials.

GRADE:

The term 'grade' as applied to a grinding wheel refers to the tenacity or hardness with which the bond holds the cutting points or abrasive grains in a place. It does not refer to the hardness of the abrasive grain. The grade shall be indicated in all bonds and process by a letter of the English alphabet, A denoting the softest and Z the hardest grade. The term 'soft' or 'hard' refers to the resistance a bond offers to disruption of the abrasives. A wheel from which the abrasive grains can easily be dislodged is called soft, whereas one which holds the grains more securely is called hard, the grades are denoted as:

GRADE OF GRINDING WHEELS

Soft	A	B	C	D	E	F	G	H		
Mediums	I	J	K	L	M	N	O	P		
Hard	Q	R	S	T	U	V	W	X	Y	Z

The grade of the grinding wheel depends on the hardness of the material being ground, the arc of the contact, the wheel and work speeds, and the condition of the grinding machine. Hard wheels are recommended for soft materials and soft wheels for hard materials.

STRUCTURE:

Abrasive grains are not packed in the wheel but are distributed through the bond. The relative spacing is referred to as the Structure and denoted by the number of cutting edges per unit area of wheel face as well as by number and size of void spaces between grains, The primary purpose of structure is to provide chip clearance and it may be open or dense. The structure commonly used is denoted by numbers as follows

STRUCTURE OF GRINDING WHEELS

Dense	1	2	3	4	5	6	7	8
Open	9	10	11	12	13	14	15	or higher

The structure of a grinding wheel depends on the hardness of the material being ground, the finish required, and the nature of the grinding operation.

Soft, tough and ductile materials and heavy cuts require an open structure, whereas hard and brittle materials are finishing cuts required a dense structure.

SPECIFICATION OF A GRINDING WHEEL:

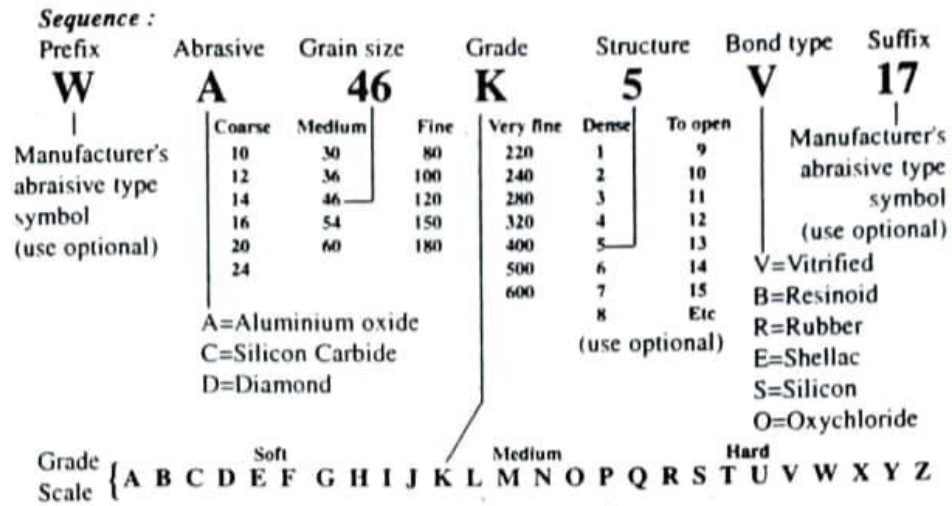

Example:

250 x 25 x 32 W A 46 L 4 V 17

Wheel dia = 250 mm

Thickness of wheel = 25mm

Bore dia = 32mm

SELECTION OF GRINDING WHEELS

In selecting a grinding wheel there are four constant factors and four variables.

GRINDING WHEEL SELECTION FACTORS

Constant factors

1. Material to be ground
2. Amount of stock to be removed
3. Area of contact
4. Type of grinding machine

Variable factors

1. Wheel speed
2. Work speed
3. Condition of the machine Personal
4. Personal factors

CONSTANT FACTORS:

1. **The material to be ground:** This influences the selection of (a) abrasive, (b) grain size, (c) grade, (d) structure, and (e) bond.

- Aluminium Oxide abrasive is recommended for materials of high tensile strength and silicon carbide for low tensile strength.
- Fine grain is used for hard and brittle materials and coarse grain for soft ductile metals.
- Hard wheel is used for soft materials and soft wheel for hard materials.
- Generally, close spacing is required for hard and brittle materials and wide for soft and ductile.
- The class of work usually dictates the bond to be used. Bond selection, of course, can be safely left to the manufacturers, if the class of work for which the wheel is required is clearly stated. However, majority of wheels are manufactured with vitrified bonds.

<i>Class of work</i>	<i>Grit</i>	<i>Grade</i>
Fettling, snagging	12-30	Q-T
Tool grinding	30-80	M-Q
General rough work (off hand)	14-30	Q-S
Cylindrical	36-120	J-N
Centreless and crank shaft	46-80	J-N
Internal	46-60	H-N
Tool and cutter	46-60	I-M
Surface grinding (segments)	20-36	G-M
Surface grinding (cylinders or cups)	20-36	G-K
Surface grinding (straight wheels)	46-60	H-K

2. **Amount of stock to be removed:** This involves accuracy and finish. Coarse grain is used for fast cutting and fine grain for fine finish; wide spacing for rapid removal and close for fine finish ; resinoid, rubber, and shellac bond for high finish.

3. **Area of contact:** Area of contact influences the selection of : (a) grit size, (b) grade, and (c) structure.

Fine grain and close grain spacing are useful where the area of contact involved is small, and coarse grain and spacing are employed where a large area of contact is concerned.

4. **Type of grinding machine:** Type of grinding machine determines to an extent the grade of the wheel. Heavy rigidly constructed machines take softer wheels than the lighter more flexible types. The combination of speeds and feeds on some precision machines may affect the grade of wheel desirable for best results.

VARIABLE FACTORS:

Wheel speed: The wheel speed influences the selection of grade and bond. The higher the wheel speed with relation to work speed, the softer the wheel should be.

RECOMMENDED WHEEL SPEED FOR DIFFERENT

<i>Type of grinding</i>	<i>Surface speed</i>	
	<i>m/min</i>	<i>ft/min</i>
(a) Vitrified bonded wheels		
Cylindrical	1500–2000	5000–6500
Surface	1200–1500	4000–5000
Internal	600–1800	2000–6000
Tool and cutter	1500–2000	5000–6500
Centreless snagging	1500–1800	5000–6000
(b) Resinoid bonded wheels		
Snagging	2000–3000	6500–9500

Work speed: The work speed with relation to the wheel speed determines the hardness of the wheel. The higher the work speed with relation to the wheel speed, the harder the wheel should be. Variable work speed are often provided on grinding machines to preserve the proper relative surface speeds between the work and wheel as the wheel diameter decreases because of wear.

Condition of the grinding machine: The condition of the grinding machine has a bearing on the grade of the wheel to be selected. Spindle loose in their bearings, and insecure or shaky foundations would necessitate the use of harder wheels than would be the case if the machine were in better operating condition.

Personal factor: The skill of workman is another variable factor which should be considered in selecting the wheel, as, for instance on off-hand grinding, it can vary the grinding costs considerably on the same work in the same factory.

KINDS OF GRINDING

Grinding is done on surfaces of almost all conceivable shapes and materials of all kinds. Grinding may be classified broadly into two groups

- 1 Rough or non-precision grinding.
- 2 Precision grinding.

Rough grinding: The common forms of rough grinding are **snagging** and **off-hand grinding** where the work is held in the operator's hand. The work is pressed hard against the wheel, or vice-versa. The accuracy and Surface finish obtained are of secondary importance.

Snagging is done where a considerable amount of metal is removed without regard to the accuracy of the finished surface. Examples of snag grinding are trimming the surface left by

sprue and risers on castings, grinding the parting line left on castings, removing flash on forgings, the excess metal on welds, cracks, and imperfections on alloy steel billets.

Precision grinding : This is concerned with producing good surface finish and high degree of accuracy. The wheel or work both are guided in precise paths.

Grinding, in accordance with the type of surface to be ground, is classified as :

1. **External cylindrical grinding.**
2. **Internal cylindrical grinding**
3. **Surface grinding.**
4. **Form grinding.**

External cylindrical grinding produces a straight or tapered surface on a workpiece. The workpiece must be rotated about its own axis between centres as it passes lengthwise across the face of a revolving grinding wheel.

Internal cylindrical grinding produces internal cylindrical holes and tapers. The workpieces are chucked and precisely rotated about their own axis. The grinding wheel or, in the case of small bore holes, the cylinder wheel rotates against the sense of rotation of the workpiece.

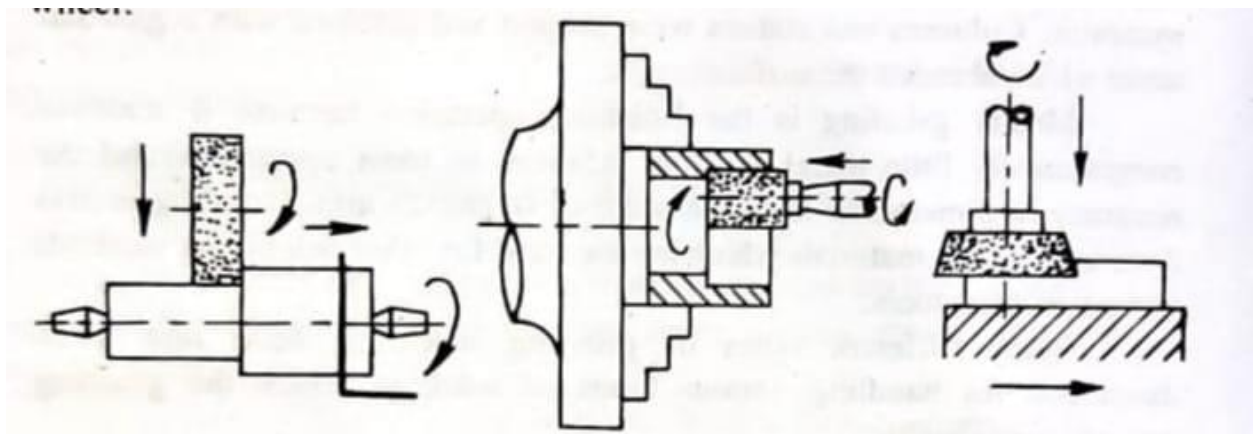

Surface grinding produces flat surface. The work may be ground by either the periphery or by the end face of the grinding wheel. The workpiece is reciprocated at a constant speed below or on the end face of the grinding wheel.

Form grinding is done with specially shaped grinding wheels that grind the formed surfaces as in grinding gear teeth, threads, splined shafts, holes, and spheres, etc.

TYPES OF GRINDING MACHINES

Various different types of grinding machines have been designed and are being used. Some of these are for roughing work, some are for precision work and some are for special purpose, i.e., to perform a specific type of operation. The varieties of grinding machines are probably larger than any other type of machine tools. However, the most commonly used types can be broadly classified as follows:

- > Roughing or Non-precision grinders.
- > Precision grinders.

ROUGHING OR NON-PRECISION GRINDERS

The main purpose of these grinders is to remove more stock than can be easily removed by other types of grinders. The quality of surface finish is, obviously, of a secondary importance.

This class of grinders includes the following machines:

- (i) Bench, Pedestal or Floor grinders
- (ii) Swing frame grinders
- (iii) Portable and flexible shaft grinders
- (iv) Belt grinders

1. Bench, Pedestal or Floor grinders

These grinders are commonly used for ‘Snagging’ and ‘Off-hand’ grinding of various materials and cutting tools in tool rooms, foundries and general repair shops, etc. They carry a horizontal spindle having grinding wheels mounted on both ends. A typical bench grinder is shown in Fig. It can be suitably bolted on a bench at convenient height.

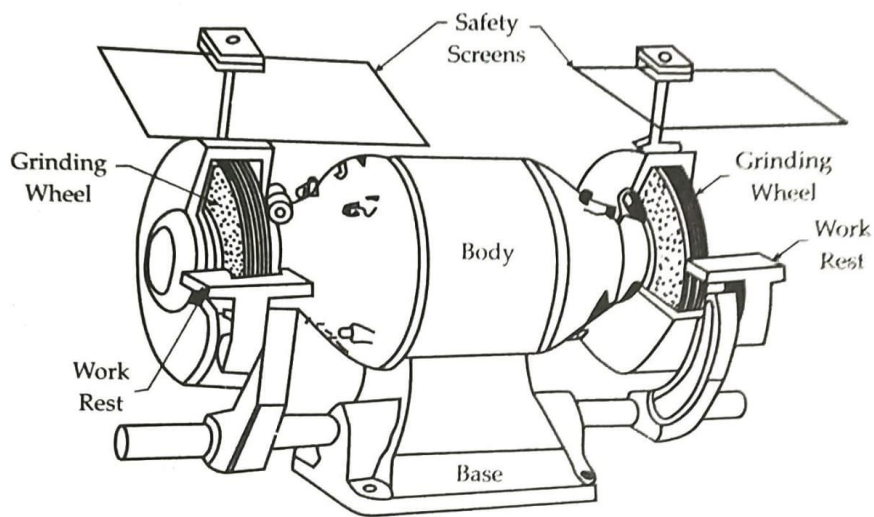

Bench grinding

The floor stand or pedestal grinder is nothing but a bench grinder of the above type mounted on a steel stand or pedestal of suitable height. The horizontal spindle carrying the grinding wheels is normally an extension on both sides of the armature shaft of the motor. These grinders can also be used for polishing by replacing the grinding wheels by polishing wheels.

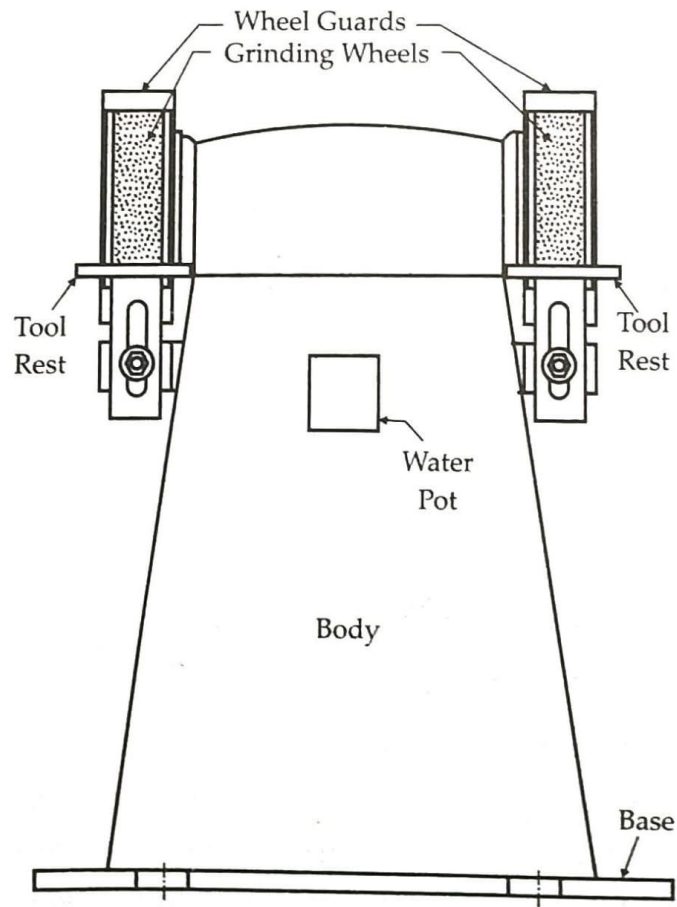

Pedestal grinder

Swing frame grinder

It consists of a 2 to 4 metres long horizontal frame, freely suspended at its centre. The frame carries a grinding wheel at its one end and motor at the other. The motor drives the grinding wheel by means of a belt. In operation, the motor is started to revolve the wheel and the frame swung by the operator about its point of suspension (centre point) to cover up the desired grinding area.

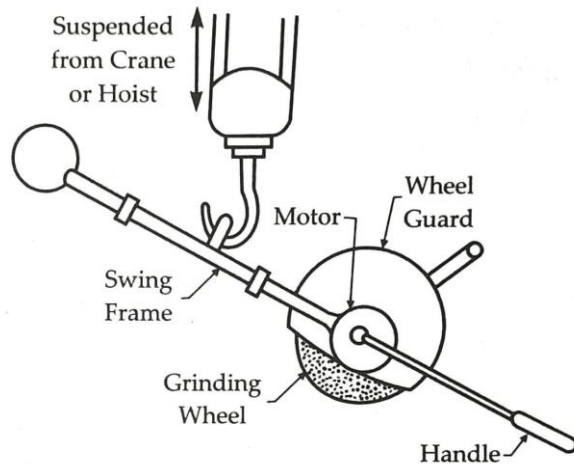

Portable and flexible shaft grinders

They resemble very much with the portable electric drills, both in construction as well as operation, with the only difference that the spindle carrying the drill chuck in the latter is replaced by a spindle, on which is mounted a small grinding wheel. A safety guard is also provided over the wheel. These grinders are vastly used in finishing castings, forgings, welded joints in structural work, removing burrs and sharp edges, preparing surfaces for welding by removing oxide coatings or scales, removing nicks, finishing jigs, fixtures, dies and similar other articles, where stock removal is the primary requirement and not the dimensional accuracy.

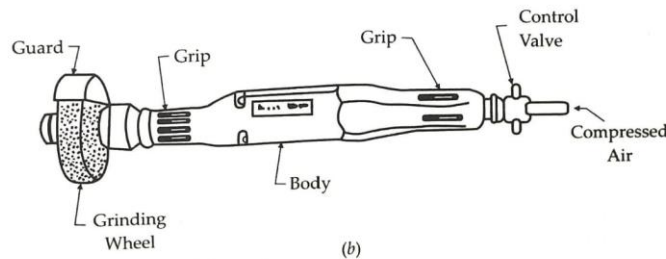
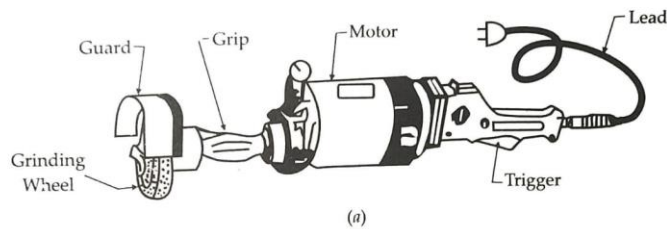

Portable type

Another machine used for the same purpose is a flexible shaft grinder, which consists of a flexible shaft driven by an electric motor. The shaft carries a chuck or collet at its end to receive small grinding tools like rotary files, mounted wheels and points and small grinding discs. The electric motor is mounted on a fixed stand.

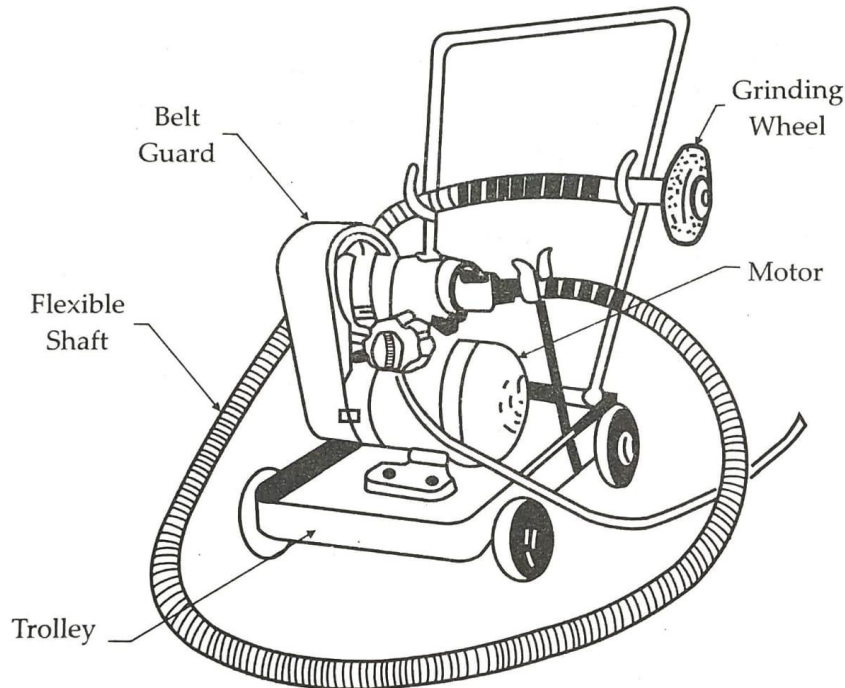

CYLINDRICAL GRINDERS

The principle of cylindrical grinding, as illustrated in Fig. involves holding the workpiece rigidly on centres, in a chuck or in a suitable holding fixture, rotating it about its axis and feeding a fast-revolving grinding wheel against the same. If the work surface to be ground is longer than the face width of the grinding wheel, the work is traversed past the wheel or the wheel past the work. Traversing of wheel or work is done either by hydraulic or mechanical power or by hand.

Feed is given to the work or the wheel at the end of each traversing movement. In case the width of wheel face is more or equal to the length of the work surface to be ground, the wheel may be fed in with no traversing movement of it or that of the work. This is known as plunge grinding.

The simplest and quite commonly used type of cylindrical grinder is a tool post grinder used on lathes. When wheels of large diameters are used, they can be mounted directly on the motor shaft. For mounting small wheels an auxiliary shaft is provided, which runs at a relatively much higher speed than the motor. Both external and internal cylindrical grinding can be done on lathe by this equipment.

Cylindrical grinding machines are mainly of the following three types:

1. Plain cylindrical grinders
2. Universal cylindrical grinders
3. Centreless grinders.

They all work on the common principle of cylindrical grinding, involving the following necessary basic movements:

1. The work must revolve.
2. The grinding wheel must revolve.
3. Either the wheel or the work must have a traversing movement past the other.
4. Either the wheel should be fed into the work or the work on to the wheel.

These cylindrical grinders are special purpose machines and will, therefore, be dealt with separately.

PLAIN CYLINDRICAL GRINDERS

On these grinders, the workpiece is usually held between two centres. One of these centres is in the headstock and the other in the tailstock. In operation, the rotating work is traversed across the face of the rotating grinding wheel. At the end of each traverse, the wheel is fed into the work by an amount equal to the depth of cut. While mounting the work between centres, the head-stock centre is not disturbed. It is the tailstock centre which is moved in or out, manually or hydraulically, to insert and hold the work. Tailstock and headstock both can be moved along the table to suit the work. The table is usually made in two parts. The upper table carries the tailstock, headstock and the workpiece and can be swiveled in a horizontal plane, to a maximum of 10° on either side, along the circular ways provided on the lower table. This enables grinding of tapered surfaces. The lower table is mounted over horizontal guideways to provide longitudinal traverse to the upper table, and hence the work. Table movements can be both by hand as well as power. Hydraulic table drives are usually preferred.

The wheel head is usually mounted on horizontal cross ways on the bed and travels along these to feed the wheel to the work. This movement is known as in feed. The wheel and work are so adjusted that the grinding force is directed downwards to ensure proper stability. A plain cylindrical grinder is shown by means of a block diagram in Fig.

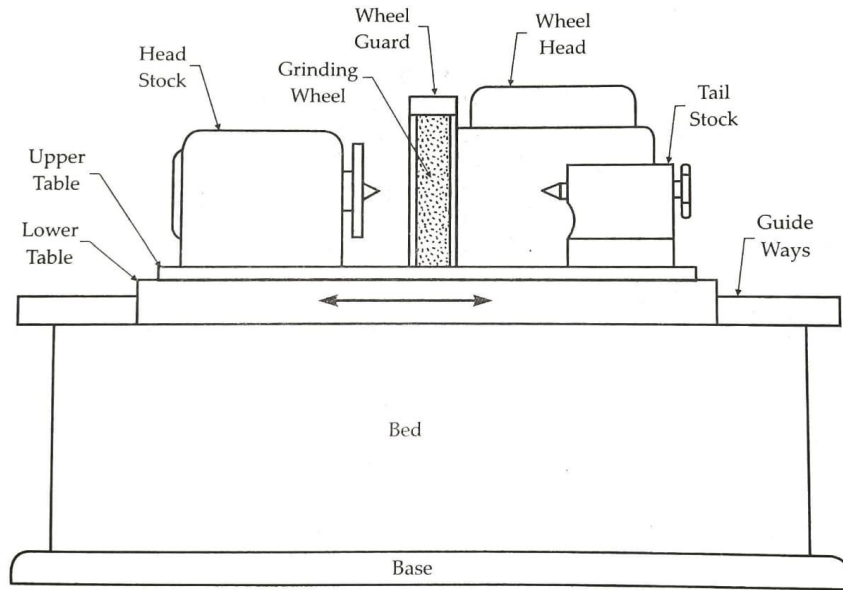

Block diagram of a Plain Cylindrical Grinder.

Fig (z)

UNIVERSAL CYLINDRICAL GRINDERS

A Universal cylindrical grinder carries all the parts and movements of a plain cylindrical grinder and, in addition, carries the following advantageous features:

- Its headstock can be made to carry a live or dead spindle, as desired, the former being needed when the work is held in a chuck:
- The headstock can itself be swivelled in a horizontal plane.
- Its wheel head can be raised or lowered and can also be swivelled to 90° to grind tapered surfaces having large taper angles.

All these factors contribute towards the greater versatility of these grinders. All the modern universal type cylindrical grinders carry hydraulic drive for wheel head approach and feed, table traverse and elimination of backlash in the feed screw nut. Most of the modern universal grinders are provided with necessary extra equipment like work rest to support slender work, wheel truing device, arbor for balancing the wheel, internal grinding spindle and a three jaw self-centering chuck, etc.

CENTRELESS GRINDERS

These grinders are also a type of cylindrical grinders only, but the principle of centreless grinding differs from centre type grinding in that the work, instead of being mounted between

centres, is supported by a combination of a grinding wheel, a regulation wheel and a work rest blade. The relative movements of the work-piece and the two wheels are shown in Fig.

The principle of centreless grinding is used for both the external grinding as well as internal grinding. Many hollow cylindrical and tapered workpieces, like bushes, pistons, valves, tubes and balls, etc., which either do not or cannot have centres, are best ground on centreless grinders.

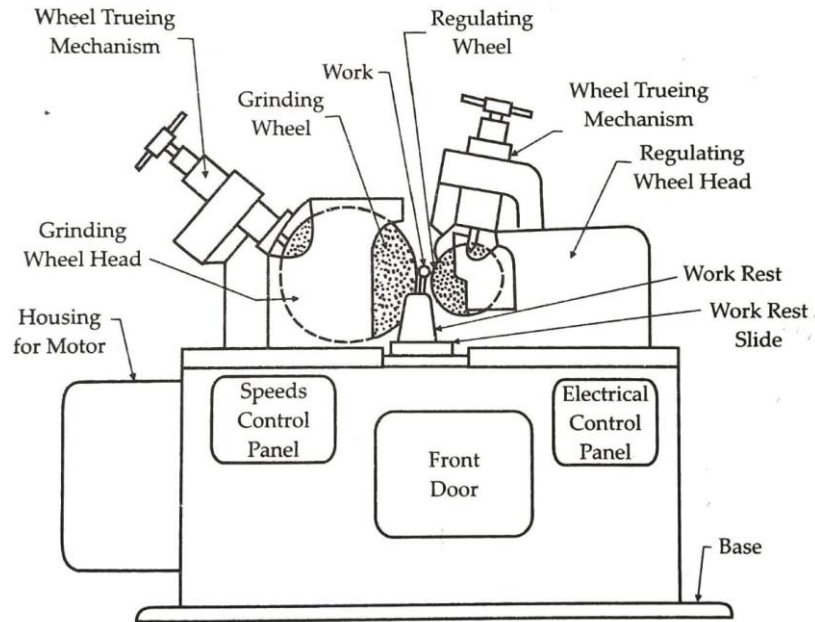

Simplified diagram of a Centreless Grinder.

A simplified diagram of a centreless grinder is shown in Fig, illustrating its main parts and controls. It carries a heavy base and two wheel heads, one carrying the grinding wheel (larger one) and the other regulating wheel (smaller one). The workpiece rests on the blade of the work rest between these two wheels. Each head carries a separate wheel truing mechanism for the wheel it carries. Housing is provided on one side of the machine body to house the main driving motor. There are two control panels on the front. The left hand panel carries controls for speed adjustments of the two truing mechanisms and the infeed grinding mechanism. The right hand panel carries controls for hydraulic mechanism, speed adjustment of regulating wheel, automatic working cycle switch, start and stop switches, etc.

In operation, grinding operation is performed by the grinding wheel only while the function of the regulating wheel is to provide the required support to the workpiece while it is pushed away by the cutting pressure of the grinding wheel.

This helps the workpiece to remain in contact with the grinding wheel. At the same time, required support from bottom is provided by the workrest as the workpiece, while rotating, rests on the blade of the workrest. The regulating wheel essentially carries rubber bond and helps in

the rotation of workpiece due to friction. The directions of rotation of the two wheels are the same. The common methods used for feeding the work are :

- > Through feed
- > Infeed
- > End feed

1. Through feed grinding

In this method of centreless grinding, the workpiece is supported and revolved as described above but is simultaneously given an axial movement also by the regulating wheel and guides so as to pass between the wheels. For this, the axis of the regulating wheel is inclined at 2 to 10 degrees with the vertical (See angle α in Fig). The amount of stock to be removed determines as to how many time a workpiece has to pass between the wheels. This method is used for straight cylindrical objects.

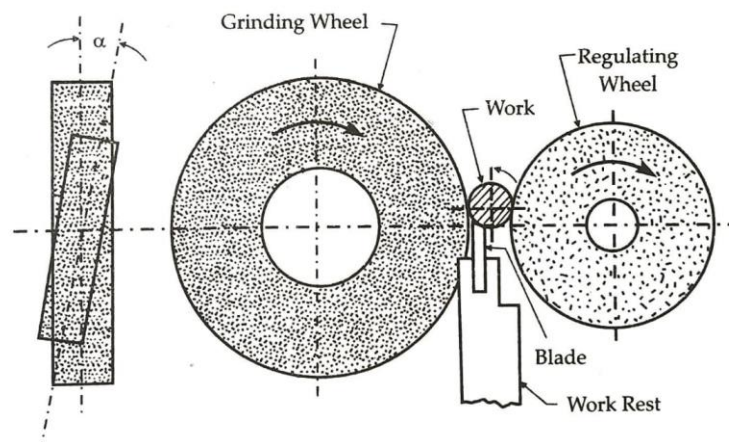

Principle of Through feed Centreless Grinding.

2. Infeed grinding

This method is similar to the plunge cut grinding method used on cylindrical grinders. Both regulating and grinding wheels are more in width than the work length to be ground. Axis of the regulating wheel is inclined a little, say about half a degree, from the horizontal. This method is used for grinding shouldered or formed components.

Before the operation, the regulating wheel is drawn away to accommodate the workpiece. After placing the workpiece on the blade of the workrest, the regulating wheel is again pushed in to press against the work. In this operation, the workrest does not carry guides. Instead, it is made to have an end stop at the rear end, as shown in Fig.

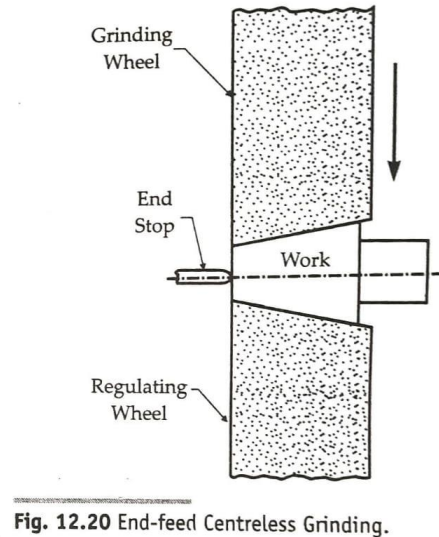
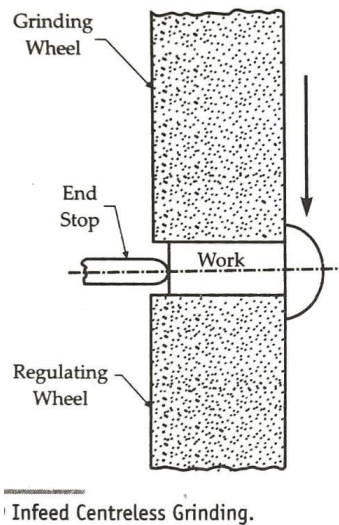

3. End feed grinding

This method is, in a way, a sort of form grinding. It is because both the wheels, i.e., the grinding wheel and the regulating wheel, are dressed to contain the required shape or form. The workpiece is fed longitudinally from the side of the wheels. As it advances between the revolving wheels, its surface is ground till its farther end touches the end stop. This method can be used for grinding of both spherical and tapered surfaces, but it suits best to the grinding of short tapered surfaces. The method of end-feed grinding is shown in Fig.

Advantages of Centreless Grinding

1. The need for centering and use of fixtures, etc., is totally avoided.
2. It can be applied equally to both external and internal grinding.
3. Once a set-up has been made, it is a faster method than centre-type grinding.
4. In through-feed method, the process is continuous as there is no idle time for the machine, because loading and unloading is done during the operation itself.
5. In infeed method also no chucking of work is needed and, as such, the idle time of the machine is almost negligible.
6. Since there is no end thrust, there are no chances of any springy action or distortion in long workpieces.
7. The operating conditions automatically provide a true floating type centre for the workpiece and, as such, the common errors normally associated with the centres and centre holes are automatically eliminated.

8. The workpiece is supported rigidly during the operation and can be subjected to heavy cuts, resulting in a rapid and more economical grinding.
9. Since the need for making and making centre holes is totally eliminated and a smaller grinding allowance is needed, the grinding time is considerably reduced.
10. Large grinding wheels are used and errors due to wheel wear are reduced. So, the requirement of wheel adjustment is minimum.
11. A very little maintenance is needed for the machine.
12. Very highly skilled operators are not needed for operating centreless grinders.
13. Direct adjustment for sizes can be made, resulting in a higher accuracy.
14. A fairly wide range of components can be ground.

SURFACE GRINDERS

Surface grinders do almost the same operation as the planers, shapers or milling machines, but with more precision. Primarily they are intended to machine flat surfaces, although irregular, curved or tapered surfaces can also be ground on them. The common classification of surface grinders can be made as follows :

1. According to the table movement :

- (a) Reciprocating table type.
- (b) Rotary table type.

2. According to the direction of wheel spindles:

- (a) Vertical spindle type.
- (b) Horizontal spindle type.

3. Special type and single purpose machines :

- (a) Face grinders.
- (b) Way grinders.
- (c) Wet belt grinders.

1. Reciprocating Table Type Surface Grinders

The principle of grinding, as applied to reciprocating table type surface grinders, is illustrated by means of the diagrams of relative movements in Figs. A reciprocating table type surface grinder may have a horizontal spindle of the grinding wheel or a vertical spindle of the same, as shown in Fig. The former will carry a straight wheel and the latter a cup type wheel. Hydraulic drives are commonly used in all such grinders. Cutting is done on the periphery of the straight wheel, in case of horizontal spindle type, and on the revolving edge of the cup wheel on vertical spindle

machines. The horizontal spindle machines are widely used in toolrooms. The workpiece is usually held on a magnetic chuck on these machines. They are vastly used for grinding flat surfaces. The machine size is designated by the dimensions of the working area of the table.

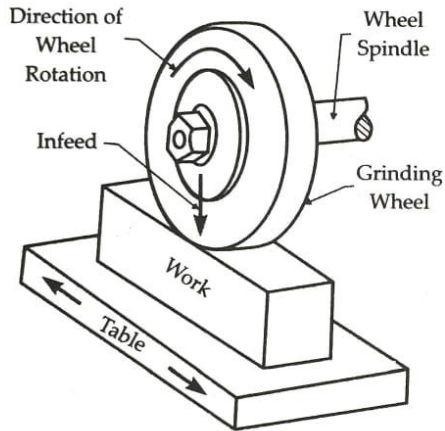

Fig. 12.21 Working principle of a Horizontal Spindle Reciprocating Table Surface Grinder.

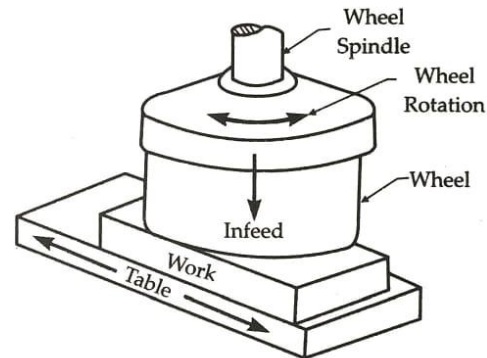

Fig. 12.22 Working principle of a Vertical Spindle Reciprocating Table Surface Grinder.

The longitudinal feed to the work is given by reciprocating the table. For giving crossfeed, there are two methods. One is to mount the table on a saddle and given the crossfeed by moving the saddle. Alternatively, the crossfeed can be given by moving the wheel-head in and out.

In case of vertical spindle reciprocating table grinders the table, alongwith the workpiece, reciprocates under the wheel. The wheel covers all or a major portion of the width of the job, as shown in Fig. 12.22. Crossfeed to the work can be given as usual by moving the saddle. A manual or power feed can be employed to feed the wheel-head vertically. An individual motor drive is usually provided to rotate the wheel.

2. Rotary Table Surface Grinders

Rotary table surface grinders are also made in two types, ie., either having a horizontal wheel spindle or a vertical wheel spindle. The relative movements of the wheel and table of a horizontal spindle type are shown in Fig. 12.24. Usually a circular shaped magnetic chuck is mounted on the circular table to hold the jobs. The workpieces are normally arranged in a circle, concentric with the round chuck. If it is a single piece, it can be mounted centrally on the chuck. The table is made to rotate under the revolving wheel, both rotating in opposite directions. The vertical feed to the wheel is given by moving the wheel-head along a column and the crossfeed by the horizontal movement of the wheel spindle. A straight wheel is used on these machines, which cuts on its periphery. Some machines carry the provision to raise or lower the table also, and also to incline the same.

Figure 12.25 illustrates the relative movements of the wheel and table of a Rotary table vertical spindle surface grinder. A cup wheel has to be used on these machines, as shown in the diagram. Vertical feed to the wheel is given by moving the wheel-head. The workpieces are mounted on the round chuck in the same way as in the horizontal spindle type. The table rotates in a direction

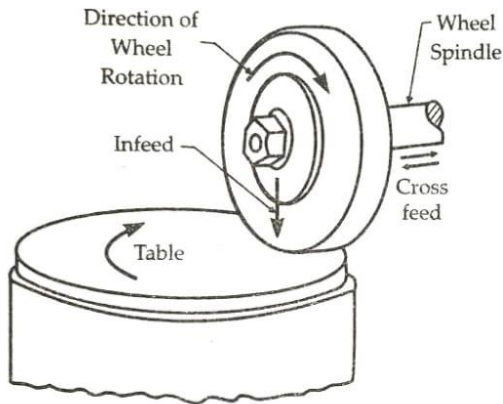

Fig. 12.24 Relative movements of different parts of a Horizontal Spindle Rotary Table Surface Grinder.

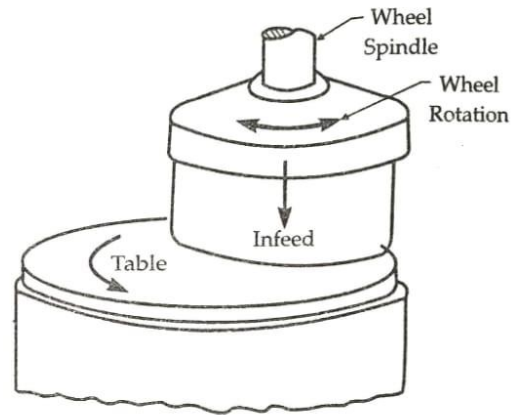

Fig. 12.25 Relative movements of different parts of a Vertical Spindle Rotary Table Surface Grinder.

opposite to that of the wheel and brings the workpieces one after the other under the rotating wheel. The table is usually mounted on a slide so as to give crossfeed.

Some rotary table surface grinders are provided with two tables instead of one so that, while the workpieces are being ground on the table, the other table can be used for loading the fresh batch of workpieces.

Other Types of Surface Grinders

1. Face grinder

It is more or less similar in operation to a horizontal spindle reciprocating table surface grinder, but differs in that a vertical flat surface is ground instead of a horizontal one. The cutting is done on the face of the wheel and not the periphery. Usually cup, ring or segmental type wheels are used, which are mounted on a horizontal spindle and fed on to the vertical surface of the workpiece, mounted on the reciprocating table. This type of machine is used for large and heavy workpieces. The work can also be held on angle plate or in well designed fixtures.

2. Way grinder

It is actually a single purpose machine used normally for grinding the bedways of different machines. It is a very large and heavy duty machine carrying a vertical spindle. Cup, ring or segmental type wheels are used on this machine. The wheel spindle can be tilted to a desired

angle to grind inclined surfaces of the ways. The table is of reciprocating type, which carries the work past the rotating wheel.

3. Wet belt grinders

These machines carry a vertical platen, which supports an endless abrasive belt revolving in a vertical direction. The table moves to feed work against the belt and the former also oscillates across the latter to effect desired grinding. The abrasive used on the belt carries the resinoid bond. This type of machine is specially used in grinding low fusion point materials as a large amount of heat generated is absorbed by the coolant, which is used in ample quantity.

Internal Machining operations

Classification of drilling machines

Drilling Machines are manufactured in various sizes and varieties to suit the different types of work. They can, however, be broadly classified as follows:

1. Portable Drilling Machine
2. Sensitive or Bench Drill
3. Upright Drilling Machine (Single spindle)
4. Upright Drilling Machine (Turret type)
5. Radial Drilling Machine
6. Multiple Spindle Drilling Machine
7. Deep hole Drilling Machine
8. Gang Drilling Machine
9. Horizontal Drilling Machine
10. Automatic Drilling Machine

PORTABLE DRILLING MACHINE

- It is a very small, compact and self-contained unit carrying a small Electric motor inside it.
- It is very commonly used for drilling holes in such components that cannot be transported to the shop due to their size or weight or where lack of space does not permit their transportation to the bigger type of Drilling machine.
- In such cases, the operation is performed on the site by means of the Portable Electric Drill. Portable Drills are fairly light in weight so that they can be easily handled by one or two men only.
- They are manufactured in different sizes and capacities; thus being suitable for a wide range of hole sizes. Also, on account of the high speeds available, a considerable saving in time is affected by their use.
- Another advantage is that the holes can be drilled by means of them at any desired inclination. Usually they are made to hold drills upto a maximum diameter of 12 mm. However, Portable drills of upto 18 mm. dia. Capacity are available.

SENSITIVE OR BENCH DRILL

- This type of Drill machine is used for very light work. Its construction is very simple and so is the operation.

- It consists of a cast iron Base having a fixed Table over it. The vertical Column carries a Swiveling table, the height of which can be adjusted vertically along the former. Also, it can be swung to any desired position.
- At the top of the column is provided the Drive, which consists of an endless belt running over two V-pulleys. One of these pulleys is mounted on the Motor shaft and the other on Machine spindle.
- No gears are used in the drive. Vertical movement to the Spindle is given by the Feed handle through a Rack and Pinion arrangement.
- The spindle usually carries Morse taper. Sensitive drills are normally manufactured having upto 20 mm Drilling Capacity in steel.

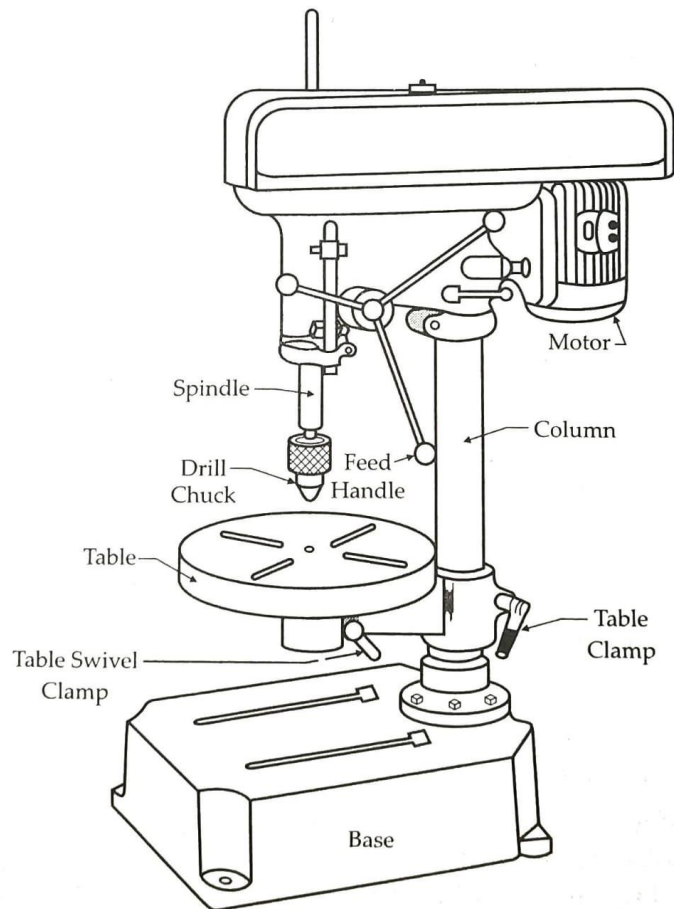

The Drive mechanism of this machine is illustrated in Fig. below.

- As the motor is switched on, the Motor shaft starts revolving and, hence, the V-pulley mounted over it. This, through the V-belt, transmits motion and power to the other V-pulley mounted over the Drill spindle.
- Thus, the spindle starts rotating and, therefore, the Cutting tool (Drill). When the Drill is required to be fed into the work, it is pressed against the work by means of the Feed

Handle. As the handle is rotated which is directly mounted on the Pinion shaft, the pinion rotates. It moves the rack longitudinally and, hence, the spindle and the drill.

- Different spindle speeds can be obtained by shifting the V-belt to different pairs of driving and driven pulleys, while the motor continues to rotate on the same speed. However, normally there is no arrangement for automatic feed on this machine.

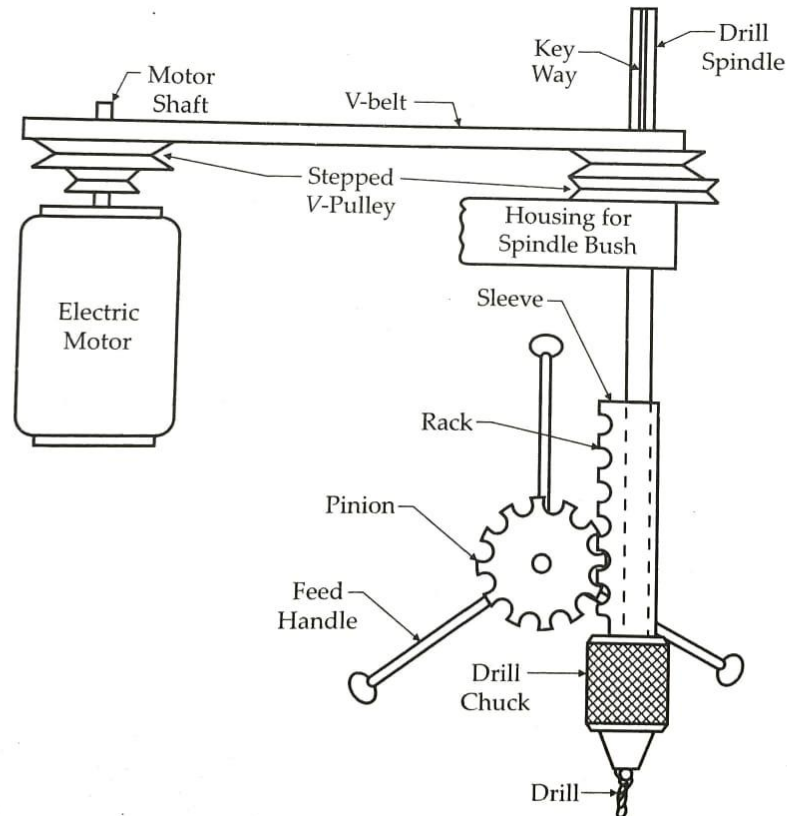

- On these machines, the drills rotate at very high speeds so that the required cutting speeds can be obtained on the peripheries of small drills used on these machines. The hand feed enables the operator to feel the gradual penetration of the drills into the work material and also sense the obstruction, if any, in its way.
- By his hand feel he can also sense if the drill is cutting properly or has become blunt and needs regrinding. For these reasons only it is known as a Sensitive Drill.

UPRIGHT DRILLING MACHINE (SINGLE SPINDLE)

- It is also known as Standard, Vertical or Pillar Drilling Machine. It is used for heavier work and has back gearing arrangement similar to a lathe.

- It specifically differs from a Sensitive drill in its weight, rigidity, application of power feed and the wider range of spindle speeds. A typical Upright drilling machine is shown in Fig.
- The Vertical Column can be either round or box type. Box type column is usually provided when the machine is constructed for relatively heavier work.
- These machines are manufactured in various sizes having different Drilling Capacities up to a maximum of 75 mm in steel. The most commonly used size is 38 mm in steel.
- A Cylindrical Vertical Pillar facilitates the swinging of table to any position and, in combination with the rotary movement of the table; it enables any part of the surface to come under the tool without disturbing the work. If a Box Type rectangular pillar is used, Vertical slides or ways are provided to enable similar settings.



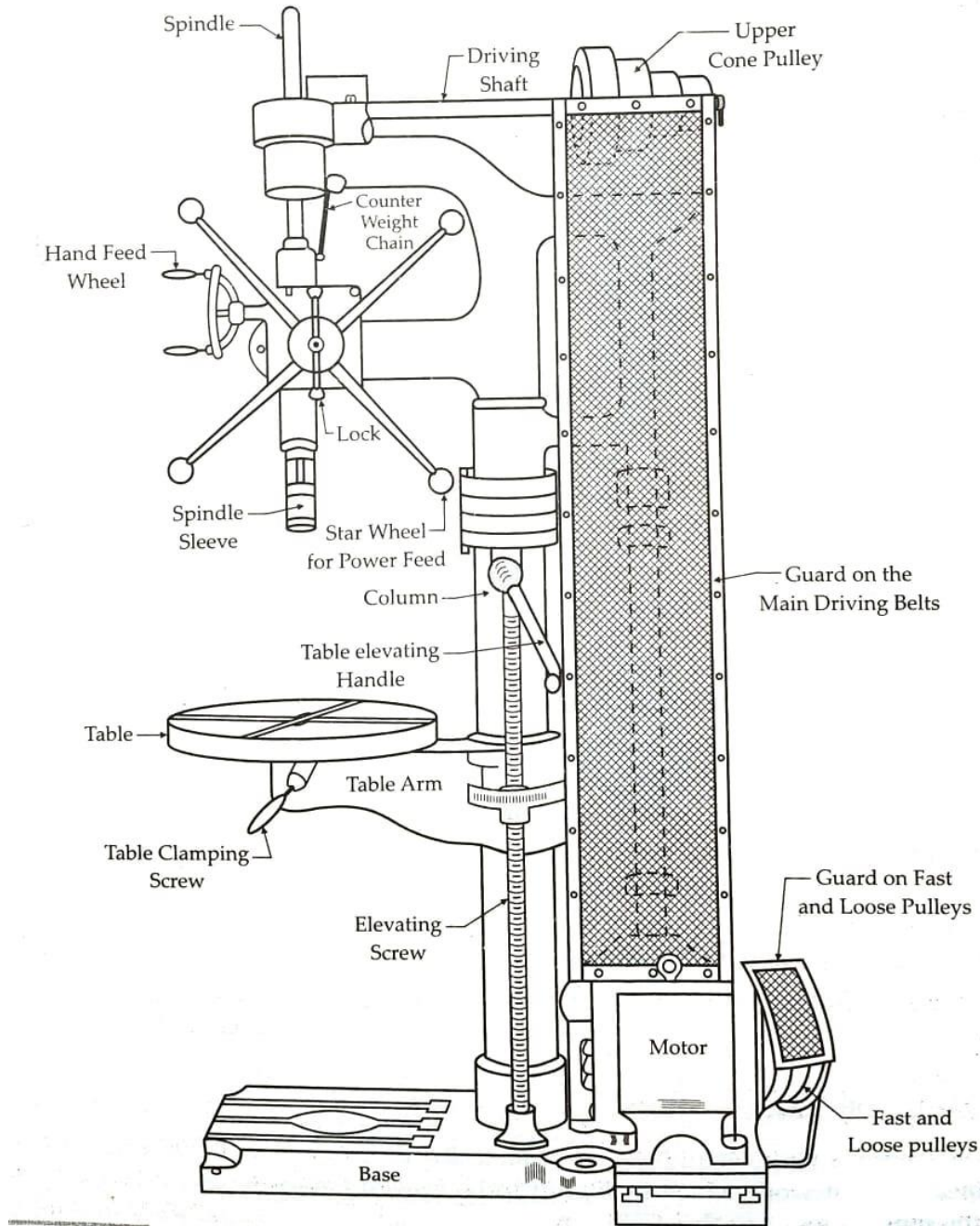

UPRIGHT DRILLING MACHINE (TURRET TYPE)

- It is a production drilling machine, which is very useful when a series of different size holes are to be drilled repeatedly or a number of different operations like drilling, reaming, counter boring, spot facing etc are to be performed in sequence repeatedly.

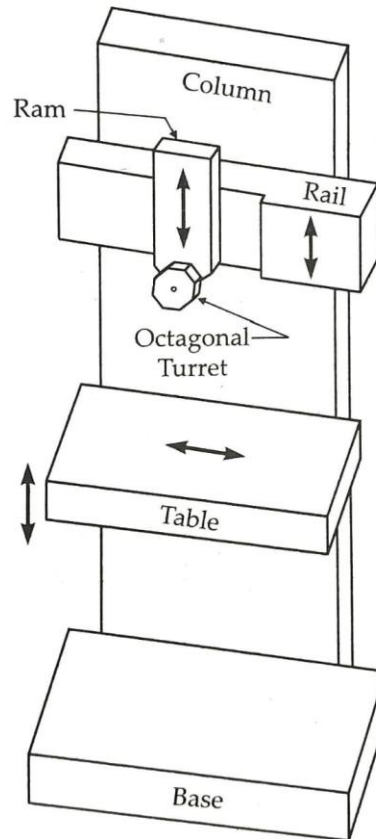

- The main parts of the machine, as shown by means of a Block diagram in Fig. include heavy Base, vertical Column, a Ram carrying Turret head and a Table.
- The Table can be raised or lowered along the column. Also, it can be moved longitudinally sideways and across to bring the job in correct position below the Tool.
- The Turret head, which carries six, eight or ten different Tool mounting positions, is mounted on a Ram. It can be easily indexed to bring the proper tool in operating position over the work and can be raised or lowered by moving the Ram upwards or downwards.
- The required tools are mounted in sequence in the Turret head so that they automatically come in operating position when the Head is indexed.
- This type of machine eliminates Tool changing time and a single machine can be used to perform a number of different operations one after the other. The smaller varieties of these machines are usually manually operated, but a large variety of these machines is Numerically Controlled (NC) Type.

RADIAL DRILLING MACHINE

- This machine is very useful because of its wider range of action. Its principal use is in drilling holes on such work which is difficult to be handled frequently.
- With the use of this machine, the tool is moved to the desired position instead of moving the work to bring the latter in position for drilling.
- This machine consists of a Base, on which is mounted a cylindrical Vertical column. A typical type of Radial Drill is shown in Fig.
- The Column carries a Radial Arm, as shown. A separate motor is provided for elevating and lowering the arm. Clamping levers are used for locking the arm at a desired height.
- Apart from this, the arm can be swung round the column to any desired angle. The Drilling Head or Spindle Head is mounted on the arm, along which it can slide horizontally.
- Different other controls for the spindle speed and feed, etc. are shown in the diagram which needs a careful study. All the above adjustments collectively contribute towards minimizing the setting time to an appreciable extent.
- A good many Radial drills are provided with a Swiveling head instead of the Fixed type. This enables drilling of holes at any desired angle. Another development in many good machines will be found that the clamping levers are interlocked with the elevating control so that the upward or downward motion will not start until and unless these levers are released.
- Also, in these machines it will not be possible to clamp the arm while the elevating mechanism is in operation. This ensures safety of one against the other.
- Some machines are fitted with an Auxiliary spindle for High speed drilling. A hole depth strip is incorporated in modern Radial drills to stop the machine automatically as soon as the required depth of hole is obtained.

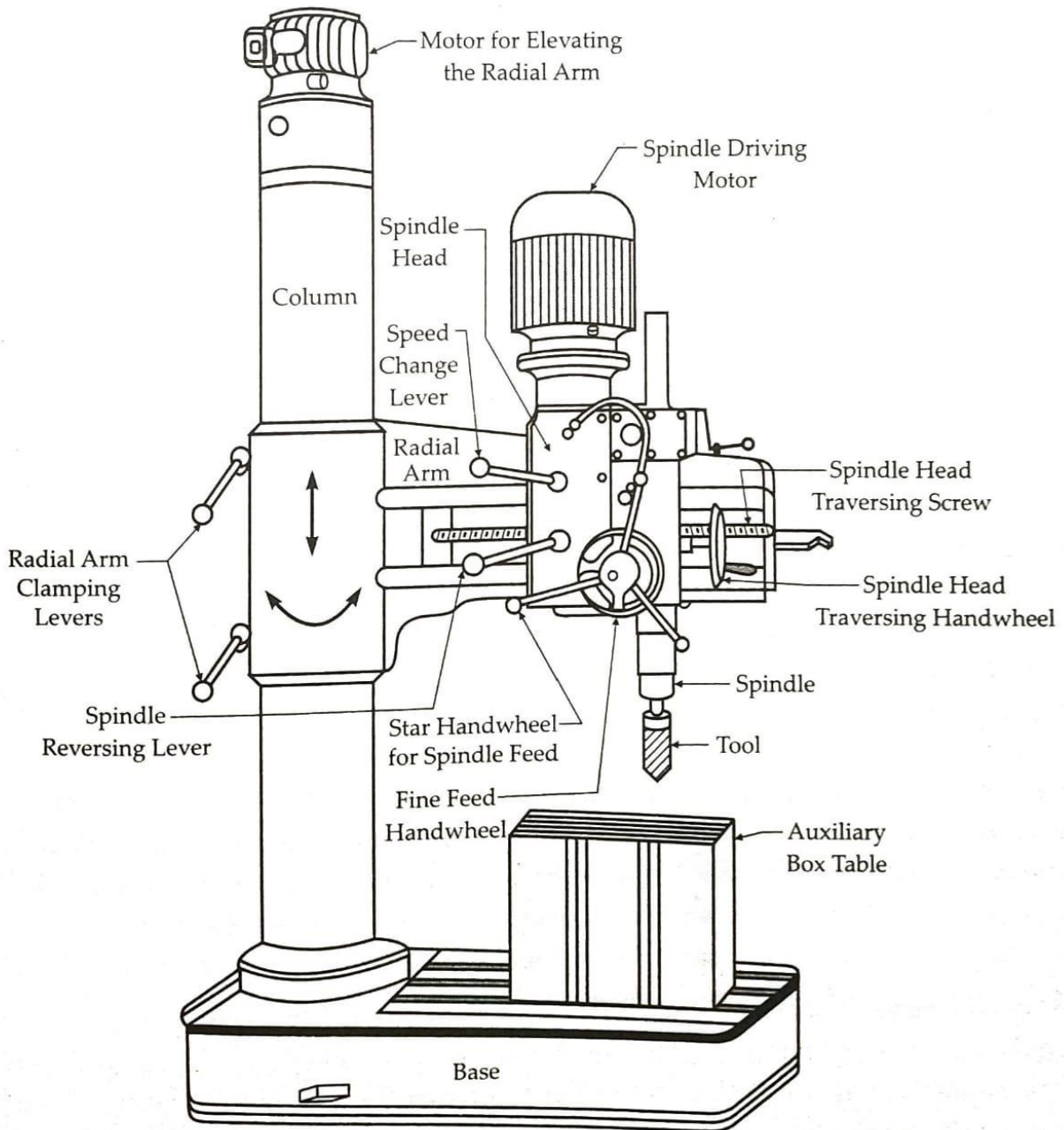

- Apart from the Fixed column type of Radial drills many other forms are also used. They include the Girder and Plate Radial Drills. These machines are of traversing type which can be moved along the rails from one position to the other, whereas the work can slide on rollers under the machine. This is essential for covering a wider area for drilling, as is required for drilling work in Boiler plates, etc.
- With these machines a larger area can be covered without using a machine of larger radial arm. Sometimes, these drilling machines are mounted on a Trolley base to have a

greater degree of mobility in order to move the machine to any position on or around the work and drill holes at any desired angles. These machines are known as Universal Portable Radial Drills.

Based on the type and number of movements possible the Radial Drills can be broadly grouped as:

1. Plant Radial Drills. Three principal movements are possible in this type of machine, viz., Vertical movement of the Arm along the Column, horizontal Sliding movement of the Drilling Head or Spindle Head along the Arm and Radial Swinging of the Arm in a horizontal plane.

2. Semi-universal Radial Drills. These machines, in addition to the above three basic movements, carry provision for swinging of the Spindle Head about a horizontal axis which is normal to the arm. Thus, the Head, and hence the Spindle, can be inclined to a suitable angle with its normal vertical position on either side, enabling drilling of holes at desired inclinations with the normal vertical position.

3. Universal Radial Drills. In this machine the Arm itself can be rotated through a desired angle along a horizontal axis. This is in addition to the four possible movements available on a Semi-universal Machine. This makes this machine highly versatile and facilitates drilling at any desired inclination and location. It is normally provided with a Geared Drive.

In this machine, the Spindle head moves on Cross-rail (arm) by means of the Hand Wheel and is provided with Locking arrangement to lock the head at any position on the arm. Vertical adjustment of the arm is made with the help of Elevating Motor. Thus, the head can be raised, lowered and swung around to any position relative to the Base; Power is transmitted from the motor to the spindle through V-belt drive.

MACHINE SIZE

- The Portable drilling machines are specified by the maximum size of the drill they are capable of holding.
- Sensitive and Upright drilling machines are specified by the largest diameter of the job in which the machine can drill a centre hole. Invariably, the Maximum drilling capacity of the machine is also mentioned in addition to the above dimension.
- Radial drills are normally specified by the length of the arm. Some manufacturers, however, specify the size of the column also.

However, in order to specify a Drilling machine fully many other parameters, like the taper in spindle, spindle travel, outside dia. of spindle nose, feed range, drilling area, required floor space, power of motor(s), net weight of machine, etc., are required to be mentioned.

In case of the Radial drill machines, the additional parameters required to be specified are the drilling, boring and tapping capacities in different metals (particularly in case of iron and steel), No. of spindle nose, drilling depth, range of spindle speeds and feeds ; working range (drill radius, vertical movement of arm, horizontal travel of drill head, swing movement of arm, horizontal travel of drill head, swing of arm, etc.), size of base plate, working surface, power of motors, net weight of machine, working space required, etc., are to be mentioned.

OPERATIONS DONE ON DRILLING MACHINES

There are a number of Operations done on a Drilling machine, as shown in Fig. These are as follows :

- Drilling
- Reaming
- Boring
- Counter-boring
- Counter-sinking
- Spot facing, and
- Tapping

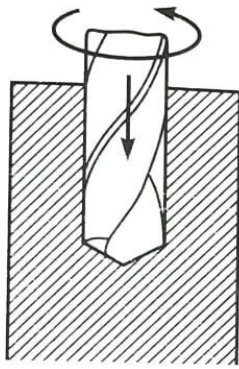

Drilling

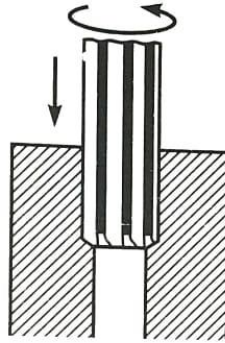

Reaming

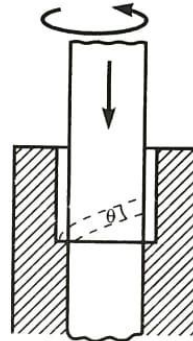

Boring

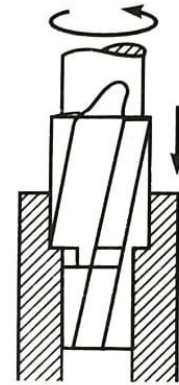

Counter-boring

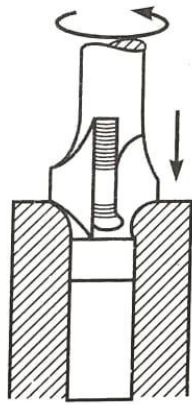

Counter-sinking

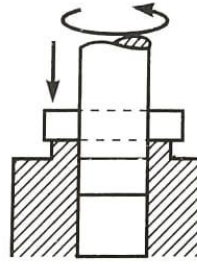

Spot Facing

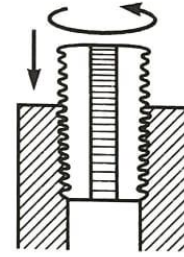

Tapping

BORING

INTRODUCTION

The operation of Boring differs from Drilling in that it implies the enlargement of an already existing hole. This hole can be due to previous drilling or produced in Casting or Forging. When small holes are to be bored particularly in small jobs, which can be conveniently held in Chucks or Face plates, the operation of Boring can easily be done on Centre lathes or Capstan and Turrets of medium size.

For large and heavy jobs, special Boring Machines are to be used, which make the operation easy and efficient. These machines are, however, production machines and their use is normally confined to those shops where their existence is justified by the need for boring on a large scale.

CLASSIFICATION OF BORING MACHINES:

Boring Machines are manufactured in various different designs and sizes. They can broadly be classified into the following three types :

1. Horizontal Boring Machines.
2. Vertical Boring Machines.
3. Jig Boring Machine.

Of the above three, the first two types include production machines, used in general production work, whereas the last one is a precision machine used for precision Boring operations, such as Jig boring.

HORIZONTAL BORING MACHINES

Table Type or Universal Type is most versatile and commonly used machine. A detailed study of this machine will, therefore, follow in this article. This machine, by means of a Block diagram, is shown in Fig.

The spindle of the machine is capable of holding Drills and Milling Cutters as well to perform the operations of Drilling and Milling.

For the same reason, this machine is also named as a Horizontal Boring, Drilling and Milling Machine.

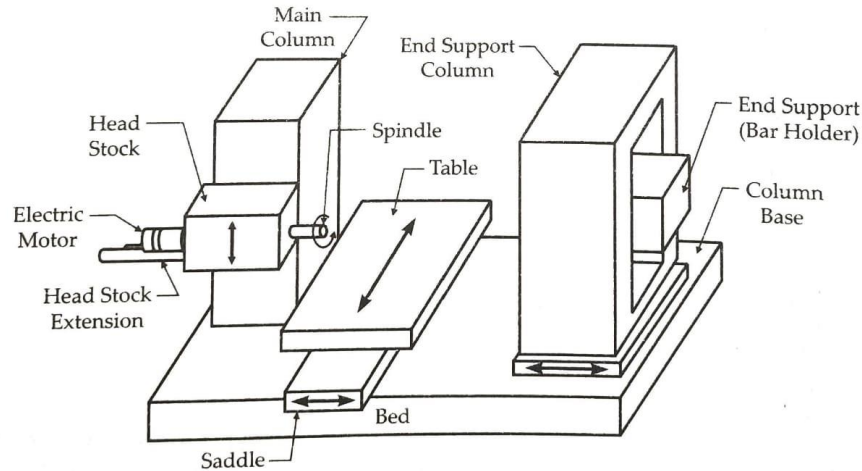

Block diagram of a Horizontal Boring, Drilling and Milling Machine.

The Principal Features of this type of machine, as shown in Fig. are the following :

1. Two Vertical Columns, one on each end of the Table.
2. A Head Stock, which can be moved vertically along the Main Column
3. A Horizontal Spindle, housed in the Head Stock, which can be rotated, fed forward and backward according to requirement.
4. A load bearing End Support, for supporting the end of a long boring bar which can be adjusted vertically along the End Support Column.
5. A Horizontal Table, mounted on a Saddle, that can be moved horizontally forward and backward and sideways by moving the Saddle.
6. A heavy and strong Bed, which carries the entire load of different parts, workpiece and tooling over it.

Multiple Head Type Horizontal Boring Machine

It consists of two Vertical Columns mounted on the sides of a stationary bed. The columns are bridged by means of Cross-rail. As a maximum, four Headstocks can be mounted on the machine, one each on the two vertical columns and two on the Cross rail. The Headstocks on the columns will have Horizontal spindles and those on the Cross rail Vertical spindles. In this way, maximum four tools can be mounted simultaneously on this machine. The work is mounted on the Table which is supported and moved on the bed. In this way, this machine very nearly resembles a Planer type milling machine. The Headstocks can be swivelled to desired angles if angular cuts are required to be taken. Thus, machining on more than one surface on a job is possible simultaneously as up to four tools can operate simultaneously on the job from different angles and at different locations.

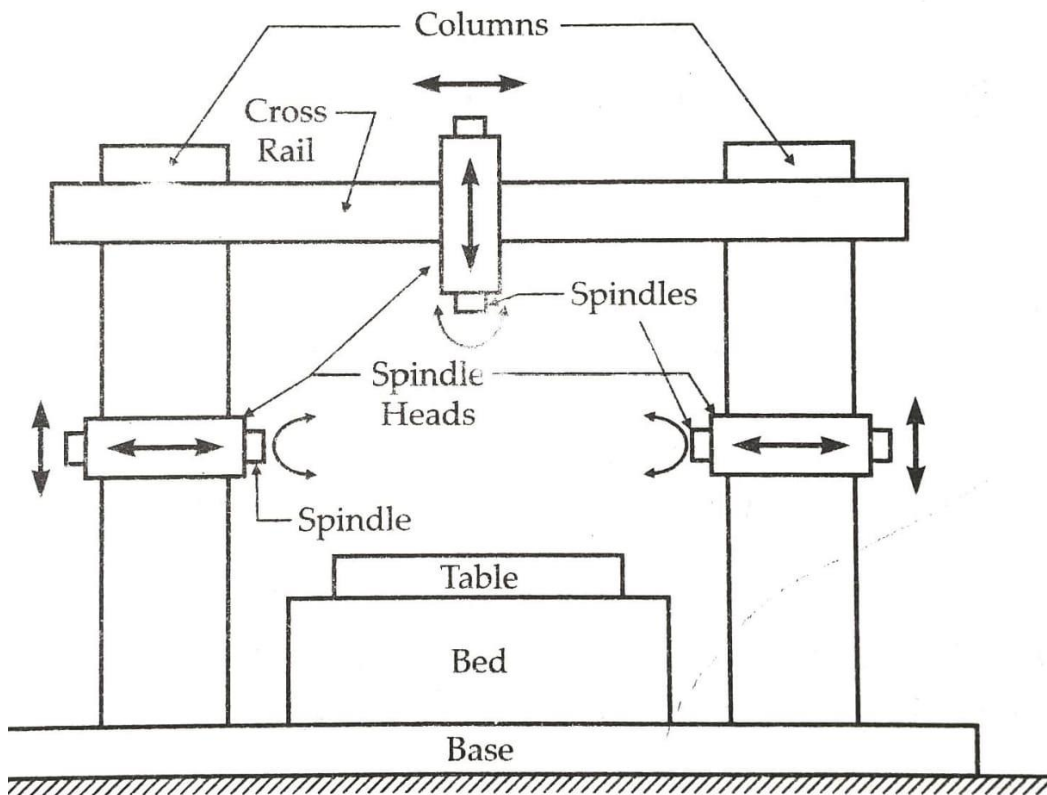

Block diagram of a Multiple Head Horizontal Boring Machine.

Holding the Work

Individual Workpieces in Jobbing work are normally held on Horizontal Boring Machines by means of the conventional Work Holding Devices like Clamps, T-Bolts, Steps blocks, Angle plates, Straps, etc., whereas in mass production work well designed Boring Zigs are preferred. These Jigs, apart from rigidly holding the work in position, also guide and support the Boring bars. Also, their use enables considerable saving of time in correct location of the workpiece in position.

Boring Tools and Bars

The Tools used in boring work are of mainly two types

- Rotating type
- Non-rotating type

Of the above two types, the first kind is used when it is inconvenient to rotate the work on account of its awkward shape or similar other reasons. Such tools are commonly used for boring work on Drilling machines, Centre lathes, Boring machines and sometimes in Milling machines.

Against this, when the work is of such nature that it can be conveniently held in Chuck, i.e., it can be conveniently rotated, the second type is preferred. This type is generally used on Centre lathes, Capstan, Turret and Automatic lathes, Vertical lathes and Boring machines.

Under the above two categories fall a number of Boring Tools. A few common ones of these are described below :

1. Forged Solid Tools

They provide, probably, the quickest method of boring in small jobs on lathes. They are generally forged out of tool steel and then ground to correct angles. They are made in pairs, consisting of a roughing and a finishing tool. Two Carbide Tipped Boring Tools are shown in Fig. These tools are held either in Turret head or sometimes in Tail stock. The work is held in a Chuck or Faceplate and revolved, the tool being fed into the job by moving the Tailstock spindle as the case may be.

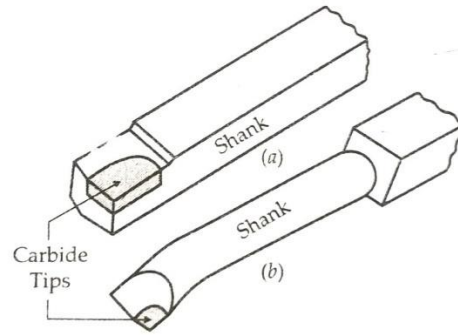

Fig. 8.6 Carbide Tipped Solid Boring Tools.
 (a) Carbide tipped tool (b) Carbide tipped tool with tool holder.

2. Boring Bars

There are many ways in which a Boring bar can be held on lathe. One method will be to hold the bar in the Tail stock and the work in Chuck or Face plate as usual. The work will rotate and the bar fed into it just as the forged tool. It will hold good both for blind as well as through holes.

VERTICAL BORING MACHINES

A Vertical Boring Machine is named so because the work held on a rotary table about a vertical axis while the tool(s) remain stationary, except for feeding. The Table, together with the work, rotates in a horizontal plane.

Mainly the following three types of Boring machines fall in this category :

1. Standard Vertical Boring Mills
2. Vertical Turret Lathes
3. Vertical Precision Boring Machines

All these machines can be used for vertical boring.

Standard Vertical Boring Mill

It consists of a heavy cast iron Bed which carries a Circular Table over it. On the sides of the bed are two Vertical Columns which are bridged together by means of a Cross-rail, as shown by means of a block diagram in Fig.

As a maximum, four Tool heads can be mounted on the machine, one each on the two Columns and two on the Cross-rail. This number can also be reduced according to the requirements. Usually the Tool heads carry the provision for being swivelled to a certain angle for taking

Angular cuts. The Work is mounted on the table which rotates about its vertical axis. The rotating work is, thus, fed against fixed tools, which results in circular cuts being taken on the job. The Table is provided with T-slots for clamping the work.

Usually large and symmetrical workpieces, such as cylindrical objects, are bored on these machines. A few examples are the Casings for Steam Turbines, Tables for Machines tools and Pressure vessels.

An important point to be noted here is that the Vertical Housings on the two sides of the table limit the size of the work that can be machined on this machine.

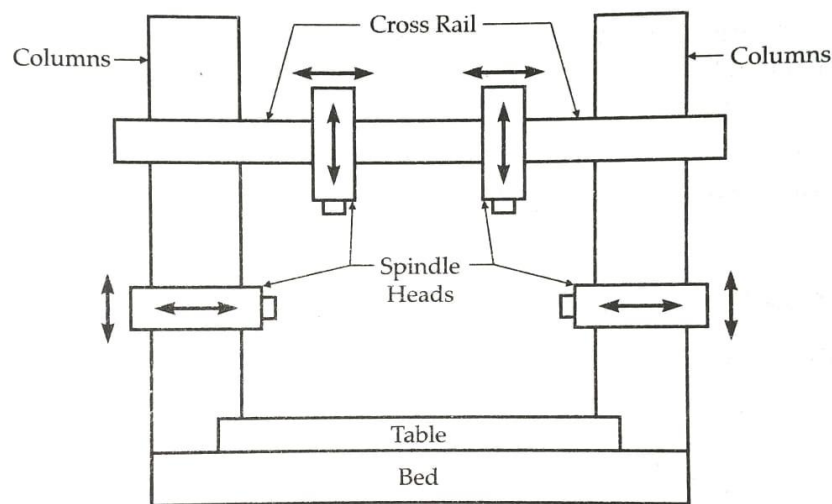

Standard Vertical Boring Mill.

THE JIG BORING MACHINE

A Jig Boring Machine is a specially designed Machine Tool used for precision location and production of holes, as are needed in Jigs, Fixtures, Templates, Dies, Gauges etc. Such a high degree of accuracy is usually called for where the relative location of different holes on the same or adjacent parts affects their operation.

In appearance and construction a Jig Boring Machine resembles very much to a Vertical Milling Machine, but it is comparatively more rigid and accurate than the latter. It essentially consists of a heavy base and vertical column. The Column, at its top, carries the Spindle head which can slide up and down along the vertical guideways provided at the front of the former. A Saddle is mounted on the horizontal ways on the top of the base to give cross-feed to the work. The Table is mounted over the saddle and the same can move to and fro at right angles to the movement of

the saddle, along the guideways provided on the latter. The work is, thus, given the longitudinal movement by moving the Table, cross movement by moving the Saddle and vertical adjustment of the tool to the work is made by moving the Spindle head up or down. A Quill is provided in the Spindle head and the spindle moves inside it.

Allied operations:

Counterboring.

By Counterboring we mean the enlargement of diameter of a hole for certain depth only. Ordinary flat cutters can be effectively used to counterbore the previously bored large holes. Tools used for Counterboring small holes, however, need a Pilot at the front end. The Tool can be in single piece or may have Inserted Cutters.

Countersinking.

It means providing a conical recess at the end of a hole to make a seat for the Countersunk Head of a mating component, usually Fasteners, like rivets and Screws, etc. For general purpose work, where a very high accuracy is not desired, a simple Flat drill ground to contain the required angle can be used.

Trepanning. It is an operation which is done when a very large hole is to be made in thin metal or when a very deep and large hole is to be made in a solid workpiece.

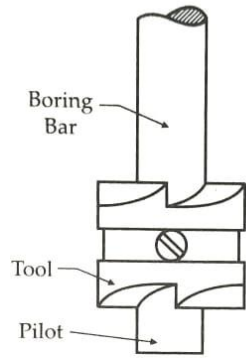

3 A Counterboring Tool.

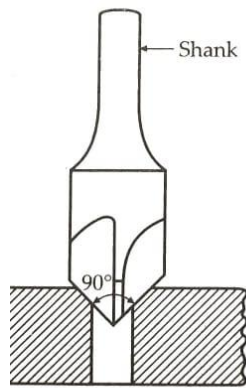

4 A Countersinking Tool.

BROACHING

Broaching is a machining operation in which a tool, having a series of cutting teeth, called Broach, is either pulled or pushed by the broaching machine past the surface of a workpiece. In doing so, each tooth of the tool takes a small cut through the metal surface.

The surface to be cut may be external or internal. When the operation is performed on internal surface it is called Internal or Hole Broaching and in case of external surface External or Surface Broaching. Most of the cutting is done by the first and intermediate teeth whereas the last few teeth finish the surface to the required size.

TYPES OF BROACHES

There is a fairly large variety of broaches in use in industry, but all of them can be classified as follows :

1. According to the method of operation - Push, pull or stationary.
2. According to the kind of operations they perform - internal and external.
3. According to their construction - Solid, built up, rotor cut, inserted tooth, overlapping tooth, progressive, etc.
4. According to their use - Single purpose or combination.
5. According to the functions - Keyway, spline, burnishing, roughing, sizing, serration, rifling, surface, spiral, etc.

Push broaches are shorter in length than the **pull broaches** of the same cross section in order to ensure adequate stiffness to resist bending. The former type is usually employed where a shorter length is to be broached and less material is to be removed. Where a considerable amount of metal is to be removed and a longer surface is to be broached a pull type broach, which carries more number of teeth and is longer, and hence removes more material, is preferred.

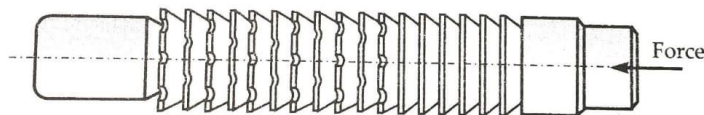

A Push Broach.

In general, it is the tool (broach) which moves while the work remains stationary, but in certain cases the broach remains stationary whereas the work pieces are moved past it as in Continuous broaching machine. A broach made in a single piece is known as a solid broach.

The internal broaches which are normally of solid type, are commonly employed for enlarging and sizing an existing hole and/or providing specific shapes to the existing holes. These holes in the components exist due to earlier operations on them, such as drilling, casting, forging, punching, etc.

Tool material:

High carbon steel: light work

HSS: commonly used for production work, mass production

Carbide tipped tools: for very hard materials, abrasives

DETAILS OF BROACH CONSTRUCTION

Figure illustrates the details of a pull type hole or internal broach for producing a cylindrical hole. The puller grips the broach at the shank end. Before the teeth, the front pilot enters the hole to keep proper alignment. The cutting teeth, which follow the front pilot, gradually increase in size. The first set of cutting teeth, called roughing teeth, does most of the cutting. They are followed by semi-finishing teeth, which remove comparatively less stock than the former.

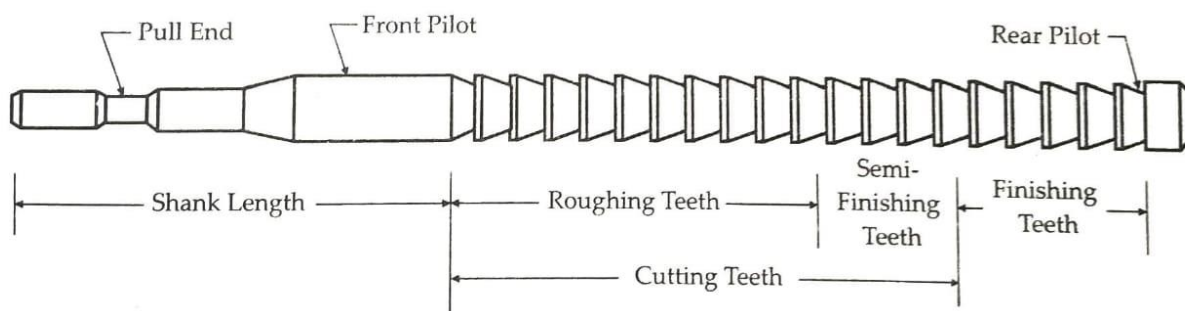

The variation in their sizes will obviously be smaller than the roughing teeth. They bring the size of the hole to roughly the required size. The finishing teeth, which follow after the semi-finishing teeth, do not practically remove any appreciable amount of stock. They are all of the same size and shape as the required size and shape of the hole, so as to produce the hole of required size and shape having a smooth finish. When the first finishing teeth are worn out, those behind them

start doing the sizing operation. The rear pilot supports the broach and keeps it aligned after the cut is over.

ELEMENTS OF A BROACH

Figure shows the details of broach teeth. It would be interesting to note that each tooth of the tool is larger than the preceding one and smaller than the one that follows except the finishing teeth, which are all of the same size.

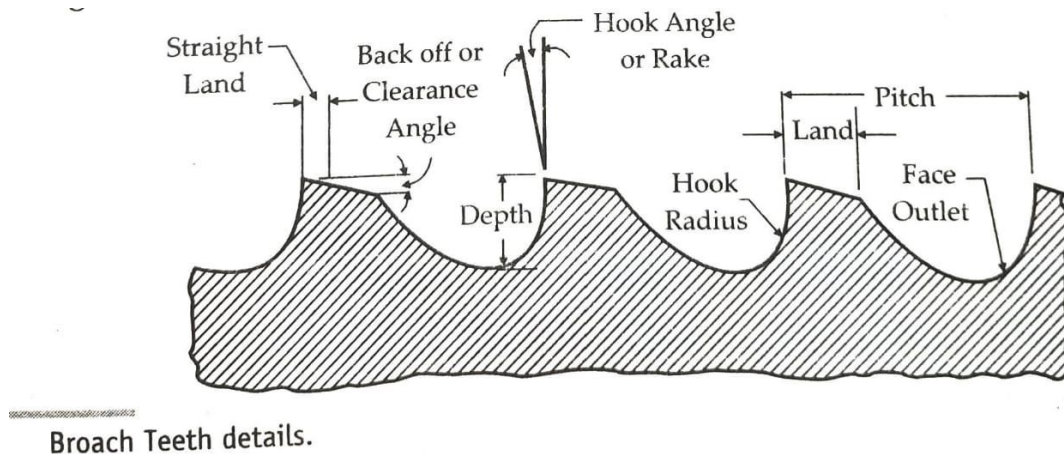

The principal elements of a common type of broach are the following

1. Pull end. That end of the pull broach, which contains shank, is the pull end. The broaching machine's puller head grips this end of the broach.
2. Front pilot. It guides the broach into the hole and keeps it concentric with the latter. This helps in starting a straight cut.
3. Rear pilot. Its size and shape conforms to those of the finished hole and provides support to the broach after the cutting process is over. After the operation, this portion of the broach is gripped by the machine to pull back the broach to the starting position.
4. Land. It is the extreme top part of the tooth and is normally ground slightly to provide clearance:

5. Tooth gullet. It is also known as face gullet or chip space. This provides space for the chips to curl and escape. If this space is not provided, or is too small to accommodate the cut chips, the chips will rub against the hole surface and spoil it. Its size varies directly as the pitch of the teeth.

6. Pitch. The linear distance measured between the cutting edge of one tooth and the corresponding point on the next tooth is called pitch. But, it is not the same for all the teeth of the broach. It is different for the three sets of teeth, i.e. roughing, semifinishing and finishing teeth. It should be large enough to allow enough space for the chips to collect. It is more important in case of long holes.

7. Hook or rake angle. It is also known as face angle. It is similar to the rake angle provided on a single point tool of a lathe and purpose is also the same.

8. Hook radius. It is the radius contained by the bottom of the gullet. It should have a very polished and smooth surface so as to prevent sticking of chips in the gullet.

USEOF FIXTURES

Use of properly designed fixtures is more pronounced and almost an unavoidable feature in broaching. It is so for the reason that very cutting forces are employed in broaching and, therefore, the workpiece always needs a proper supporting and clamping device. Secondly, because broaching machines are always used in mass production work the use of fixtures affects a considerable saving in setting time and labour. The following are the functions of all broaching fixture :

- To locate the work in correct position.
- To support and hold the work rigidly during the operation.
- To index the work to the next position before the second cut starts, if more than \ one cut are required.
- To guide the broach during the operation.
- To move the work to correct position before the start of the operation and remove it from there after the operation is over.

PRINCIPLE OF BROACHING

The operation of broaching involves the use of a multitooth cutter, called broach, which has already been described earlier. The teeth of the broach are so designed that the height of the cutting edge of the following cutting tooth is slightly more, equal to the feed per tooth, than that of the preceding tooth. Thus, when the broach is fed in a straight line, either over an external surface or through an internal surface, the metal is cut in several successive layers by successive teeth of the broach. The thickness of each layer is same and is known as feed per tooth. The sum of thicknesses of all the layers taken together is called the depth of cut.

During the operation, either the broach is fed past the stationary workpiece or the workpiece past a stationary broach, the former practice being more common. The surface produced carries an inverse profile to that of the broach teeth. A specific point regarding broaching is that out of all the basic machining processes it is the only process in which the feed is in-built in the tool (broach). This feed is equal to the chip thickness. This aspect is amply clear in the given diagrams (Figs. 14.7 and 14.8).

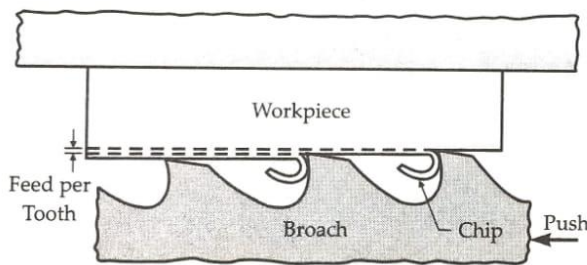

Fig. 14.7 A Push type Broach in use for Machining an external surface.

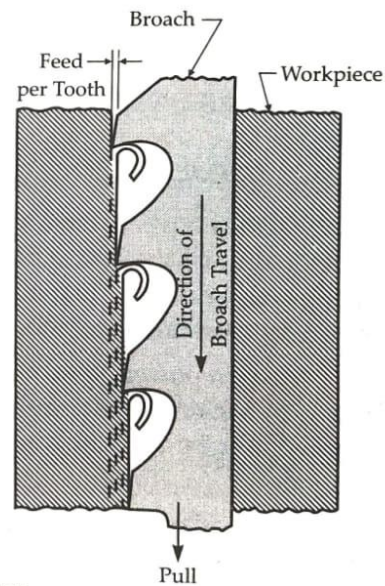

Fig. 14.8 A Pull type Broach in use for Internal broaching on a vertical pull-down type machine.

Figure 14.7 shows a push type broach being fed past the stationary work, on a horizontal broaching machine, to machine an external surface on the workpiece. Figure 14.8 shows a pull type broach being fed into a hollow workpiece, on a vertical pull-down type machine, to machine

an internal surface of the workpiece. In this case also, the workpiece will remain stationary. Both the operations are performed in a single linear stroke of the broach. After the end of the stroke in both the above operations the broach is retracted to the original starting position, the finished part replaced by a new workpiece and the operation repeated as usual.

TYPES OF BROACHING MACHINES

There are a number of different designs available of broaching machines in different sizes and capacities. A few of them, like arbor press, are manually operated and the rest all are power operated. Manually operated machines are used normally where only a few pieces are required to be broached and the components are small in size. Where broaching is to be done on mass scale, a power driven machine is always used. The common types of broaching machines can be classified as follows :

1. According to the power employed - manually operated or power driven.
2. According to the direction of broach movement in cutting - Horizontal or vertical.
3. According to the method of cutting Pull, push or continuous.
4. According to the condition of movement of the tool relative to the work - Moving or Stationary broach.
5. According to the type of drive - Mechanical or hydraulic drive.
6. According to the number of pull heads - Single or multiple pull-head.

Brief description of construction and working of some common types of broaching machines are given in the following articles.

BROACHING PRESSES

Various types of presses have been developed which are used for broaching. As stated earlier in the last article, a small number of jobs can be easily broached on a manually operated arbor press, shown in Fig.

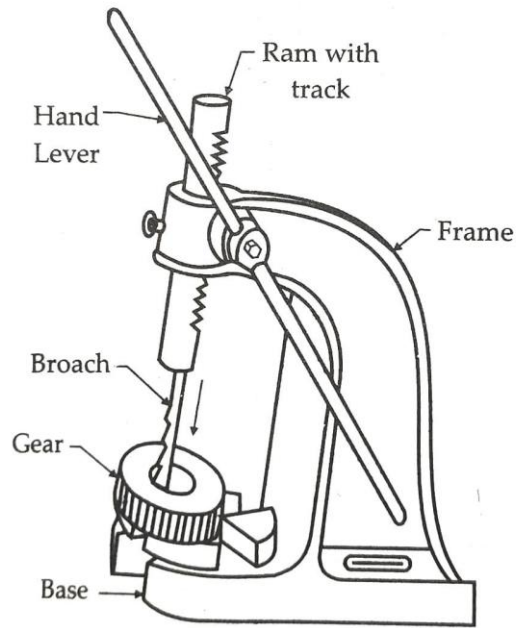

Fig. 14.9 An Arbor Press Being used to broach a key way in a gear.

This is the simplest and lightest of all the presses used in broaching work and is manually operated. Modern power press, used for broaching on mass scale, usually carries a hydraulic drive. Push type broaches are commonly used on these machines. Both internal as well as external broaching can be done, but the former is more commonly performed on these machines. These machines are made in various different sizes, ranging in capacity from 250 kg to 35 tonnes pressure. These machines are generally available in the vertical type. The workpiece is placed on the machine table and the vertical ram of the machine, carrying the broach, pushes the latter past the work. The main advantage of using presses for broaching is that they are relatively less expensive as compared to other broaching machines. Another advantage with these presses is that they can easily be switched over to perform other operations like bending or trimming and drawing, etc., when broaching is not being done. Thus, the idle time is fully utilised. It is for these reasons that presses are mostly preferred over other regular types of broaching machines in those shops where broaching is not a regular requirement.

HORIZONTAL PULL TYPE BROACHING MACHINES

Almost all the modern horizontal pull-type broaching machines carry a hydraulic drive for reasons of getting the required power and efficient drive. A pressure-gauge is always fitted

which readily indicates the pull being applied on the tool. As indicated by the name of the machine, a pull-type broach is always used. These machines are used both for internal as well as external broaching. Those used for hole or internal broaching carry a bed quite similar to that of a lathe and the broach moves like the tailstock on the bed ways. The other class, which is used for external or surface broaching, carries the guideways on a vertical surface, normal to the bed, along which the broach moves. Fixtures are invariably used on these machines. In addition to this, the cutting pressure, or to say the pull, exerted on the broach further helps in clamping the work in position. The broach is pulled by a horizontal ram, which is driven by a hydraulic piston and cylinder mechanism incorporated in the body of the machine. The mouth or front part of the ram carries a hole to receive the shank of the broach puller. The shank of the broach is passed through the initial opening of the job and connected to the broach puller or pulling head. The rear end of the broach is usually held in a supporting slide, which travels along with the broach during the operation, just like a travelling steady on a lathe. These machines are manufactured in both fully automatic and semi-automatic types. In both the types, automatic stops or limit switches are provided to control the length of stroke of the ram.

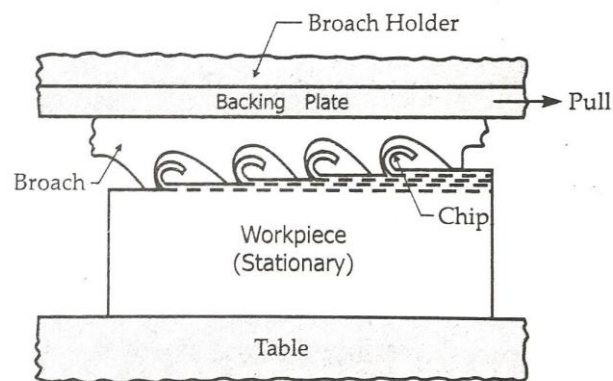
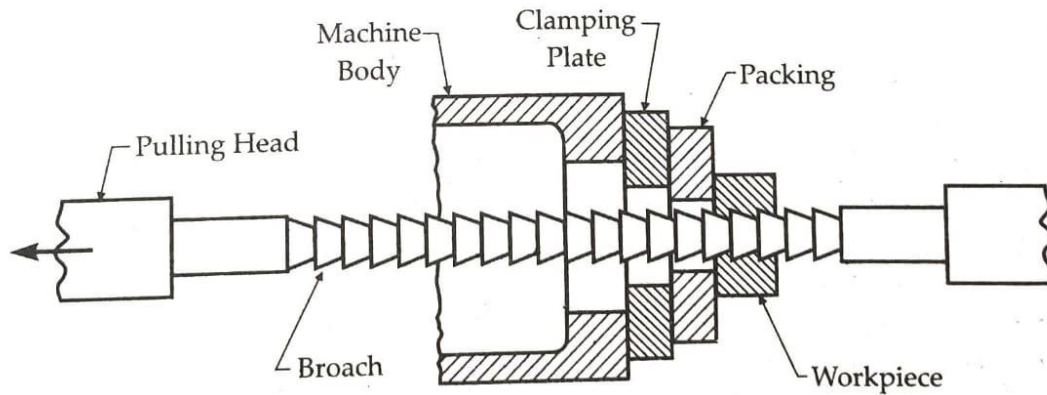

Fig. 14.10 A schematic diagram showing Principle of Surface Broaching on a Pull type horizontal machine.

Principles of both surface broaching and internal broaching operations, as performed on a horizontal pull-type broaching machine, are shown in Figs. 14.10 and 14.11 respectively. Figure 14.10 shows the relative movement of the broach with respect to the stationary workpiece while broaching an external surface. Figure 14.11 illustrates the movement of the broach against the

workpiece, held stationary, while broaching internal splines in the boss of a gear (workpiece). The pull ends of both these broaches are held in suitable pulling heads and then are pulled past the work.



Showing Principle of Internal Broaching performed on a Horizontal pull type broaching machine.

SURFACE FINISHING OPERATIONS

23.1 INTRODUCTION

Various basic or preparatory metal machining operations, *viz.*, turning, boring, drilling, shaping, milling, etc., have been described earlier in this book. The parts produced through those operations, although fairly accurate in size, do not carry a very high degree of surface finish. As such, in good many cases, they do not readily suit the service they are intended for and are to be subjected to one or more further operations to obtain the desired surface finish on them. These precision surface finishing operations, employed for producing extremely high surface finish, are called *micro-finishing operations* for the reason that the surfaces finished through these processes are specified in micro-units, such as *microns* or *micro-inches*. Where very close dimensional accuracy is required, in addition to a highly finished surface, the operations performed for the above purpose include :

- Some grinding operations,
- Honing, and
- Lapping,
- Superfinishing.

Against this, where the primary requirement is only the high degree of surface finish, and a very close dimensional accuracy is not the primary need, the desired surface finish is obtained by :

- Polishing,
- Tumbling, and
- Buffing,
- Burnishing.

Different types of grinding operations have already been described in chapter 13. The remaining surface finishing operations will, now, be described in this chapter.

23.2 LAPPING

It is an abrading process employed for improving the surface finish by reducing roughness, waviness and other irregularities on the surface. It is used on both heat-treated and non-heat-treated metal parts. It should, however, be noted that where good appearance of the job surface is the only requirement, it should not be employed, since there are other finishing methods which will give the same desired result with low cost. It should be used only where accuracy is a vital consideration in addition to the surface finish. The basic purpose of *lapping* is to minimise the extremely minute irregularities left on the job surface after some machining operation.

In brief, we can say that **Lapping** is basically employed for removing minor surface imperfections, obtaining geometrically true surfaces, obtaining better dimensional accuracy and, thus, facilitate a very close fit between two contacting surfaces.

The material to be selected for making a **lapping tool or lap** largely depends upon the individual choice and the availability, and no specific rule can be laid for the same. The only consideration that has to be made is that the material used for making a lap should be soft so that the abrasive grains can be easily embedded in its surface. In case a hard material is used for making the *lap*, the abrasive particles will quickly go out of their places. The commonly used materials are soft cast iron, copper, brass, lead and sometimes hardwood.

Abrasives. All the abrasives, *i.e.*, *natural* as well as *artificial* are used for lapping. *Aluminium oxide* is preferred for lapping soft ferrous and non-ferrous metals. *Silicon-carbide* and *natural corundum* are used for hardened steel parts. Powdered *garnet* is used for lapping soft ferrous and non-ferrous metals, *emery* for hardened steel components and *diamond* for extremely hard materials like cemented carbides.

Vehicle. The term '*Vehicle*' in lapping denotes the lubricant used to hold or retain the abrasive grains during the operation. To some extent it also controls the cutting action of the latter. Some common vehicles used in lapping include the vegetable or olive oil, lard oil, water soluble oil, mineral oil, kerosene mixed with a little machine oil, alcohol, and heavy grease. For cleaning the laps, naphtha is commonly used. No specific recommendations can, although, be laid for the selection of a particular vehicle, still the vehicle used should possess the following qualities :

1. It should be able to hold the abrasive particles uniformly during the operation.
2. Its viscosity should not be considerably affected by temperature changes.
3. It should not evaporate quickly.
4. It should be non-corrosive.
5. Its viscosity should suit the operating speeds.

Lapping allowance. As already described earlier, the *lapping operation* is not primarily meant for removing metal. As such, enough care should be taken to ensure that too much material is not left on the work surface to be removed by lapping. The endeavour should always be to obtain as good surface finish through earlier machining operations as it is possible so that a very negligible amount of stock remains to be removed by lapping. It should be borne in mind that smaller the amount of stock left, quicker will be the lapping process and higher will be the dimensional accuracy obtained. Keeping in view the above discussions, the recommended *range of lapping allowance* to be left is as follows :

1. *General lapping work*

Allowance on surface	0.0075 mm to 0.0125 mm
Allowance on dia or thickness	0.015 mm to 0.05 mm

2. *For lapping the work which has been finish ground*

Allowance on surface	0.005 mm
Allowance on dia.	0.01 mm

Pressure and Speed for Lapping

The following magnitudes of *pressures* are recommended for lapping :

For soft materials	0.07 – 0.2 kg/cm ²
For hard materials	0.7 kg/cm ²

Normal *speed range* used in *rotary lapping*, *i.e.*, when the work and lap have a rotary motion relative to each other, varies from 1.5 m/sec to 4.0 m/sec.

23.3 TYPES OF LAPPING OPERATIONS

Lapping operations can be broadly classified into the following *two* main groups :

- Equalising Lapping
- Form Lapping

1. Equalising Lapping

It is the operation of running two mating parts or shapes together with an abrasive between them. When two such surfaces run together in constant contact with the abrasive, their surface finish is improved and any deviation of shape corrected. Those results can be easily seen during seating of tapered valves in their seats or when gears are rotated together with these objectives.

2. Form Lapping

As is clear from the name itself, it is not merely rubbing of surfaces together but it is the *shape of the lap* that is responsible for finishing a corresponding work surface. Obviously, the *lap* used in the operation will be a *form lap*, *i.e.*, containing the shape to be lapped.

23.4 LAPPING METHODS AND MACHINES

Lapping is done in the following *two* ways :

- By hand – called *hand lapping*.
- By machines – called *machine lapping*.

Hand Lapping

In *hand lapping*, either the lap or the work-piece is held by hand and the motion of the other enables the rubbing of the two surfaces in contact. This method is widely used in lapping press work dies, moulding dies and metal moulds for casting, limit gauges, etc. In some cases the lapping compound is placed between the two surfaces and the two are rubbed together by moving one of these by hand, the other remaining stationary. A few examples of this method are lapping of surface plates, engine valve and valve seat, etc. Whatever may be

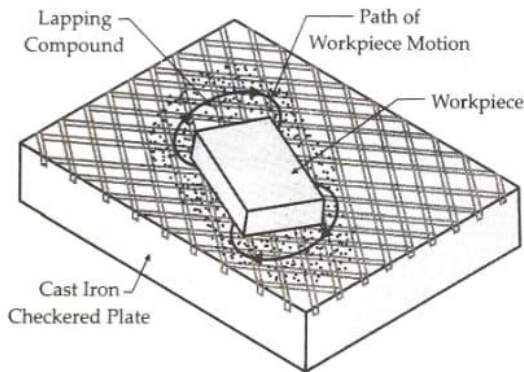

Fig. 23.1 An example of Hand Lapping.

the method used, out of the above two, it is necessary that the work and lap are not rigidly guided with regard to one another and that their relative movement is kept along an ever changing path, *i.e.*, not repeated along the same path. For example, Fig. 23.1 shows the bottom surface of a hardened steel piece being lapped on a *cast iron plate*. The top surface of the *plate* is made perfectly plane, finely finished and checkered by providing cross grooves, as shown. These grooves help in collecting excess abrasive grains and removed chips.

Before commencing the operation, the *lapping compound* (*fine grained abrasive*) is spread over the top surface of the plate. *Grey cast iron*, which is porous and soft, is the material used for the plate. It is, therefore, able to retain the *abrasive grains* (*lapping medium*). The workpiece is placed over the lapping medium and rubbed over the same. As already indicated above, the movement of the workpiece has to be along an irregular path, not just to and fro. In this case, the workpiece is shown moving along a path taking a shape of English numeral '8'.

Machine Lapping

Machine lapping is performed for obtaining a highly finished surface on many articles like races of ball and roller bearings, gears, crankshafts, machine bearings, pistons, pins and gauges, gauge blocks, various automobile engine parts and micrometer spindles, etc. Many different types of machines are used in lapping. A typical vertical spindle machine consists of *two wheels* (circular plates), one above and the other below. The workpieces are placed

between the two and the loose abrasive grains with vehicle are fed. A modification of this machine consists of two bonded abrasive wheels in place of the above rotating wheels. Obviously, no loose abrasive is required in this case. In both the machines, the lower wheel rotates and the upper one does not, but floats over the workpieces. These two machines can be used only for circular and flat work.

The working principle of a typical *Vertical Spindle Lapping Machine* is shown in Fig. 23.2. The workpieces are loaded in *conditioning rings* or *cages* on the rotary lower plate, which rotates about a vertical axis, as shown. At the same time, the conditioning rings also rotate along with the workpieces in their own positions. The combination of these two rotary motions provides a gyratory motion to the workpieces, due to which the entire surfaces of the two plates are covered. This results in an even wear of the plate surface and, therefore, its flatness is maintained. The upper plate just provides a floating action and helps in maintaining parallelism. Most of the commonly used engineering materials can be lapped by this type of arrangement. In case of slender jobs, a *workholder* is incorporated between the two lap plates to keep the workpieces in proper alignment with the plates.

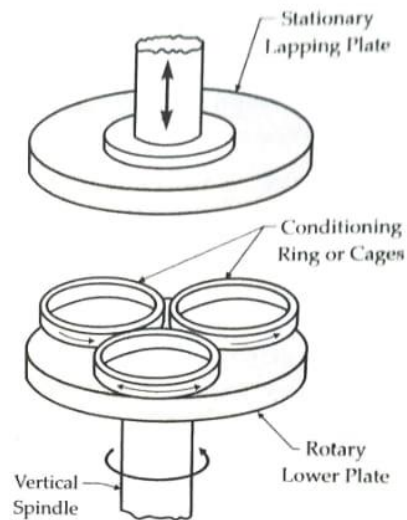

Fig. 23.2 Working principle of a Vertical spindle Lapping machine.

Some *modern lapping machines* are provided with vibratory motion instead of rotary motion, the lower plate carrying an *abrasive paper* fixed on its top surface. Workpieces are held over this paper by providing light pressure from the top plate. The lower table is vibrated and, as a result, the workpieces flow on the emery paper for lapping.

For lapping crank shafts and pins, etc. an abrasive-belt machine is commonly employed. This machine is a horizontal spindle machine, of which the spindle carries the crank shaft. During the operation, the crankshaft gets a small reciprocating motion. This machine neither uses the embedded abrasive laps nor the bonded wheels. Instead of them, coated abrasive like paper or cloth are used.

A centreless grinding machine can be conveniently adopted to perform lapping operation for round objects. The bonded wheels used in this case will be sufficiently large so that the workpiece is subjected to the abrasive action of the wheel for a longer period on each pass. Another special feature of these wheels will be that they will have their grains of a much finer grit. Rest of the setting and operation will be quite similar to centreless grinding, described in chapter 13.

23.5 HONING

It is also an abrading process, used for finishing previously machined surfaces. It is mostly used for finishing internal cylindrical surfaces such as drilled or bored holes. The tool used, called a **hone**, is a bonded abrasive stone made in the form of a stick. Although honing enables the maximum stock removal out of all the surface finishing operations, still it is not primarily a metal removing operation. However, this higher stock removing capacity enables the application of honing for correcting slight out of roundness or taper. Hole location cannot be corrected through it. The usual amount of stock left for removal by honing is from 0.1 mm to 0.25 mm, although it is capable of removing the stock up to 0.75 mm. Honing is performed at relatively slow speeds in the range of 10-30 metres/min.

The *honng tool* works more or less in the same way as an expanding reamer. The honing stones are so held in a *holder* or *mandrel* that they can be forced outwards by mechanical or hydraulic pressure against the surface of the bore. Aluminium oxide, silicon carbide or diamond grains of suitable grit are bonded in resinoid, vitrified or shellac bond to form the honing stones, usually carrying impregnated traces of sulphur or wax for longer tool life and better cutting action. Both internal cylindrical and flat surfaces can be honed. But, the process of *honng* is largely applied to internal cylindrical surfaces only. A *hand honng tool* is shown in Fig. 23.3.

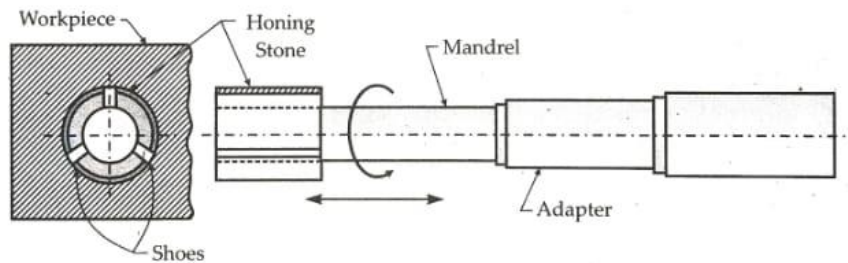

Fig. 23.3 A hand honing tool and honing process.

The Hand Honing Process

Honing is a '*wet*' process and it is necessary that a suitable coolant be used in ample quantity during the operation. In small parts, honing can be done *by hand*. In this, the hone is rotated and the workpiece moved over rotating tool back and forth by hand. The length of stones used is about half of that of the hole and the over travel at the end of each stroke is about one-third of the stone length.

Machine Honing

The process of honing can be done on many general purpose machines also, such as lathes and drilling machines. Where the stationary type of machines do not suit the nature of work, a portable electric drill can be used for this purpose by fitting a hone in place of the drill

the reciprocating motion being given by hand. In production work, where honing is to be done on a large scale, such machines will fail to give satisfactory and economical results. In such cases, the use of regular machines only will give the desired results. These honing machines are made in various types and sizes. The most common classification of these is as follows :

1. Horizontal Honing Machines

These machines are mostly used for honing comparatively longer jobs, such as gun barrels. All such machines carry a horizontal spindle, on which is mounted the honing tool. On some machines the workpiece is mounted on a table which reciprocates hydraulically to move the work to and fro on the hone, which rotates about its own axis and also, simultaneously, oscillates a little. The oscillating motion of the hone may be controlled hydraulically or mechanically. In some machines the work is held in a horizontal position and rotated about its own axis. No reciprocating motion is given to it. Against this, the honing tool, which is mounted on a travelling head, is rotated and reciprocated to give the same result as above. The latter type of machine is used for extremely long jobs. A suitable gauge is always provided to indicate as to whether the correct size has been reached or not. These machines may carry a single or double spindles.

2. Vertical Honing Machines

These machines hold the work as well as the tool in vertical positions. They are available in both single and multiple spindle types. Usually, the spindle heads, and hence the tools, reciprocate and not the workpieces. Suitable fixtures are usually employed to hold the workpieces in position. Most of the modern machines carry a hydraulic drive for their spindle heads and the tools. These machines are best suited for shorter jobs. In appearance these machines resemble the drilling machines. In honing work the *vertical machines* are more widely used than the horizontal ones. A *honing tool head* used on *Vertical honing machines* is shown in Fig. 23.4.

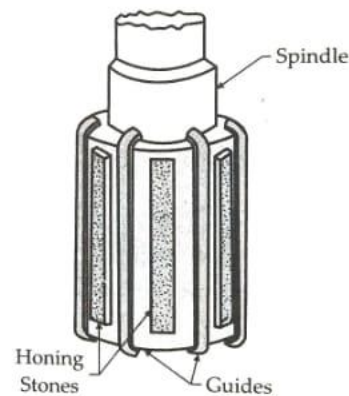

Fig. 23.4 Honing tool head for Vertical machines.

23.6 SUPERFINISHING

Superfinishing is more or less like a lapping process with a specific difference that the abrasive used is a bonded abrasive. The abrasives are used in a particular way under controlled conditions to produce a high quality surface finish on the work surface. It should be particularly noted that it is not essentially a metal removing operation and it is necessary, therefore, that in order to have a rapid rate of production, all the components to be superfinished should first be finished, through other operations, very nearly to the final size. On an average the best results can be obtained by leaving only 0.0025 mm to 0.005 mm stock to

be removed by super finishing to bring the work to the correct size, although up to 0.025 mm can be removed through this operation. In order to bring the work to such a close dimensional accuracy, grinding is usually employed prior to superfinishing.

Principle of Operation

The principle of superfinishing is shown schematically in Fig. 23.5. One face of the *abrasive block (stone)* is given the shape of the surface to be superfinished. This block is held in a suitable *holder or quill* and placed on the work surface. The quill is spring loaded to provide a light pressure on the work surface. The work piece is rotated at a very slow surface speed of the order of 2 to 20 m/min. As the work rotates, the abrasive block reciprocates forwards and backwards at a rapid rate. In order to cover the entire length of the workpiece, the block overruns by an amount 1.5 mm to 6 mm on both ends of its stroke. A suitable lubricant is

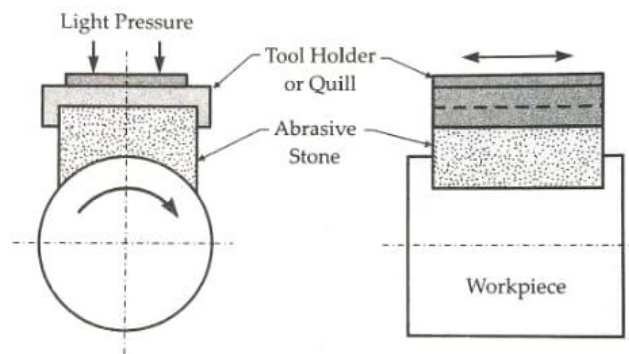

Fig. 23.5 Principle of Superfinishing Operation.

generally used in the process. An oscillatory motion obtained due to the combination of rotary motion of work and reciprocating motion of the abrasive block, with rubbing of the stone against the work surface, results in the production of a superfinished surface.

Although, this operation can be performed on a small scale on some conventional machine tools like lathe, for performing superfinishing on large scale, specially designed and built *Superfinishing Machines* are used. They usually carry hydraulic drives for workholder reciprocation. Both external and internal surfaces can be superfinished. Also, *superfinishing machines* are available in horizontal and vertical types. Most of the superfinished surfaces are usually flat or cylindrical.

On considering the other aspects of this process, it will be observed as resembling to the *honing process* in that it makes use of bonded abrasive sticks. It is necessary, therefore, to compare the two. The relative comparison below will reveal the difference between these two processes :

- (i) It is possible to create dimensions, *i.e.*, the desired size through honing while superfinishing is employed only for obtaining a high quality surface finish with no appreciable amount of stock removal.

- (ii) The honing process needs only two motions whereas superfinishing may involve many. With the result, the path of an abrasive grain is never repeated.
- (iii) The honing process is mostly employed for finishing internal surfaces, whereas superfinishing is largely used for outside surfaces.
- (iv) Superfinishing is done at much lower operating speeds than honing.
- (v) The total pressure on the work is too low in superfinishing as compared to honing, enabling finishing of even the very delicate parts.
- (vi) The length of stroke in superfinishing is very short, usually 1.5 mm to 6 mm, as compared to honing. With the result, there is no appreciable accumulation of chips and, therefore, no scratches are produced on the job surface.

23.7 POLISHING

It is a surface finishing operation which is employed for removing scratches, tool marks and similar other irregularities from the job surfaces produced through other operations, like machining, casting or forging. The primary object of this operation is only to improve surface finish and it is, therefore, employed only where dimensional accuracy is not to be closely controlled.

This operation is performed by means of abrasive coated wheels or belts. The wheels used are disc shaped and termed as **bobs** and **mops**. The former are made of leather, felt or wood, to the periphery of which are coated the abrasive particles with the help of glue. These wheels operate at a speed of 1200 to 1500 metres per minute (linear) and are the first to be used in the operation. They are followed by the other type of wheels, called *mops*, which normally operate between 1000 to 1500 metres per minute. They are made of cloth, or leather. Both natural and artificial abrasive grains are used for coating these wheels, but in either case they should be of a very fine grit. This operation may be done by hand or machines. In some cases, where only a few pieces are to be polished, the polishing wheel can be attached to the spindle of a pedestal grinder in place of the regular grinding wheel, and the operation performed by feeding the work against it by hand. For production work, specially designed semi-automatic and automatic polishing machines are available.