

A LABORATORY MANUAL
FOR
THEORY OF MACHINES AND MEASUREMENTS LAB
(PR- 1)
IN ACCORDANCE TO SYLLABUS (2019-20)

BY S.C.T.E & V.T, ODISHA

SEMESTER – 4TH

DEPARTMENT OF MECHANICAL ENGINEERING



GOVERNMENT POLYTECHNIC, JAJPUR

ODISHA – 755019

AFFILIATED TO S.C.T.E & V.T, ODISHA AND A.I.C.T.E,
NEW DELHI.

PR-1 THEORY OF MACHINES AND MEASUREMENTS LAB

Name of the Course : Diploma in Mech/ & Other Mechanical Allied Branches

Course code:		Semester	4th
Total Period:	90	Examination	3 hrs
Lab. periods:	6 P/W	Term Work	25
Maximum marks:	100	End Semester Examination:	75

SL. No Content

- 1 Determination of centrifugal force of a governor (Hart Nell / Watt/Porter).
- 2 Study & demonstration of static balancing apparatus.
- 3 Study & demonstration of journal bearing apparatus.
- 4 Study of different types of Cam and followers.
- 5 Study & demonstration of epicyclic gear train.
- 6 Determination of the thickness of ground M.S flat to an accuracy of 0.02mm using Vernier Caliper.
- 7 Determination of diameter of a cylindrical component to an accuracy of 0.01mm using micrometer.
8. Determine the heights of gauge blocks or parallel bars to accuracy of 0.02mm using Vernier height gauge.
9. Determine the thickness of ground MS plates using slip gauges.
10. Determination of angel of Machined surfaces of components using sin bar with slip gauges.

EXPERIMENT NO-01

AIM OF THE EXPERIMENT:-To determine the centrifugal force of a governor (Hart Nell/Watt/Porter).

OBJECTIVE:-After performing the experiment students will be able to

- i) Know the uses and application of governor in different areas.
- ii) Find the centrifugal forces at different speeds.
- iii) Draw graphs between centrifugal force vs speed.

APPARATUS REQUIRED:-

Sl no	Equipment	Specification	Quantity
01	Universal Governor	Watt	01
02	Universal Governor	Hart nell	01
03	Universal Governor	Porter	01
04	Tachometer	Digital	01

THEORY:

The function of a governor is to regulate the mean speed of an engine, when there are variations in the load e.g. when the load on an engine increases, its speed decreases, therefore it becomes necessary to increase the supply of working fluid (fuel). If the load on the engine decreases, its speed increases and thus less working fluid is required. The governor automatically controls the supply of working fluid to the engine with the varying load conditions and keeps the mean speed within certain limits.

The governors may, broadly, be classified as:

1. Centrifugal governor
2. Inertia governor

The centrifugal governors may further be classified as follows:

1. Pendulum type (watt governor)
2. Loaded type
 - i. Dead weight governor (Porter and Proell governor)
 - ii. Spring controlled governors (Hartnell governor, Hartung governor, Wilson Hartnell governor and Pickering governor)

Centrifugal Governor:-

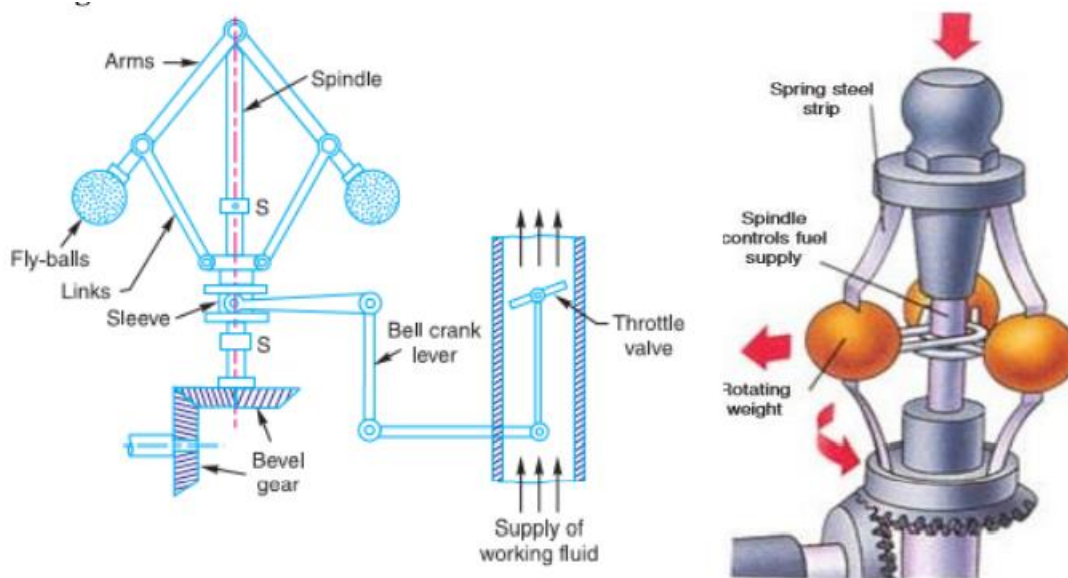

Fig1

Figure: centrifugal governor (watt type)

The centrifugal governors are based on the balancing of centrifugal force on the rotating balls by an equal and opposite radial force, known as the controlling force. It consists of two balls of equal mass, which are attached to the arms as shown in Fig1. These balls are known as governor balls or fly balls. The balls revolve with a spindle, which is driven by the engine through bevel

gears. The upper ends of the arms are pivoted to the spindle, so that the balls may rise up or fall down as they revolve about the vertical axis. The arms are connected by the links to a sleeve, which is keyed to the spindle. This sleeve revolves with the spindle; but can slide up and down. The balls and the sleeve rise when the spindle speed increases, and falls when the speed decreases. In order to limit the travel of the sleeve in upward and downward directions, two stops S, S are provided on the spindle. The sleeve is connected by a bell crank lever to a throttle valve. The supply of the working fluid decreases when the sleeve rises and increases when it falls.

When the load on the engine increases, the engine and the governor speed decreases. This results in the decrease of centrifugal force on the balls. Hence the balls move inwards and the sleeve moves downwards. The downward movement of the sleeve operates a throttle valve at the other end of the bell crank lever to increase the supply of working fluid and thus the engine speed is increased. In this case, the extra power output is provided to balance the increased load. When the load on the engine decreases, the engine and the governor speed increases, which results in the increase of centrifugal force on the balls. Thus the balls move outwards and the sleeve rises upwards. This upward movement of the sleeve reduces the supply of the working fluid and hence the speed is decreased. In this case, the power output is reduced.

PROCEDURE:-

1. Fix the links as per the diagram.
2. Ensure that all the fittings are tight.
3. With the help of variable voltage supply slowly increase the rpm of the governor.
4. Note down the speed.
5. Note down the lift of the sleeve, due to increase in speed.
6. Take readings at variable speeds.
7. Calculate centrifugal force for each reading.
8. Plot height vs speed and centrifugal force vs speed graphs from the above readings.

PRECAUTIONS:

1. Do not keep the mains on when trial is complete increase the speed gradually.
2. See that at higher speed the load on sleeve does not hit the upper sleeve of the governor.
3. While closing the test bring the dimmer to zero position and then switch OFF
4. Do not touch the equipment while in running condition

5. Use safety shoes.
6. Before starting the experiment check all the fittings.

WATT GOVERNOR

It is assumed that mass of the arms; links and sleeve are negligible in comparison with the mass of the balls and are neglected in analysis.

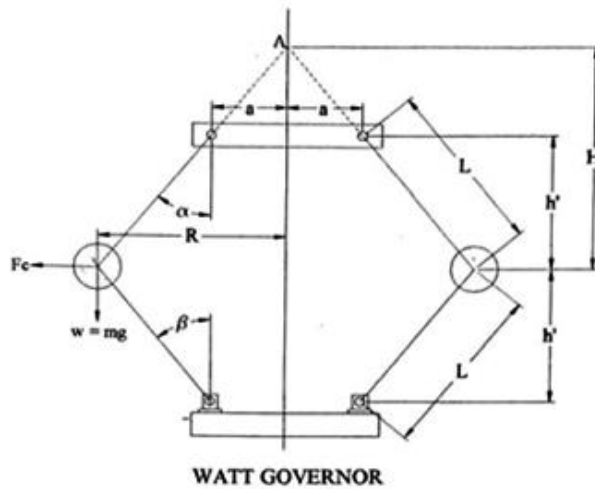

Taking moments about point A
 $F_c \times H = m \times g \times R$

i.e

$$m \times \omega^2 \times R \times H = m \times g \times R$$

Therefore $H = \frac{g}{\omega^2}$

Also $\omega = \frac{2\pi N}{60}$ radian/sec

Therefore $H = \frac{g}{\left(\frac{2\pi N}{60}\right)^2}$

$$N = \sqrt{\frac{91.2g}{H}}$$

OBSERVATIONS AND CALCULATIONS

$L = 125\text{mm}$

$h' = 108\text{mm}$

$$w = 0.750\text{kg}$$

$$g = 9.81\text{m/sec}^2$$

$$a = 42\text{mm}$$

OBSERVATION TABLE

$X'' = \dots\dots\dots\text{mm}$

Sl no	X' (mm)	N_{act} (R.P.M)
1		
2		
3		
4		

CALCULATIONS

$$X = (X' - X'') = \text{_____ mm}$$

$$h = \left\{ h' - \left(\frac{X}{2} \right) \right\} = \text{_____ mm}$$

$$\alpha = \cos^{-1} \left(\frac{h}{L} \right) = \text{_____}$$

$$H = \left\{ \left(\frac{a}{\tan \alpha} \right) + h \right\} = \text{_____ mm}$$

$$N_{theo} = \frac{60}{2\pi} \sqrt{\frac{g \times 1000}{H}} = \text{_____ RPM}$$

$$R = \{ a + (L \sin \alpha) \} = \text{_____ mm}$$

$$\omega = \frac{2 \times \pi \times N_{act}}{60} = \text{_____ rad/sec}$$

$$F_{act} = \frac{W \times R \times \omega^2}{g \times 1000} = \text{_____ kg}$$

Sl no	N actual in rpm	Lift /height in (mm)	Centrifugal force (F _{act}) in Kg
1			
2			
3			

$$F_{theoretical} = \frac{W \times R}{H} = \text{.....Kg}$$

Plot the following graphs

1. Height of sleeve lift vs Speed
2. Centrifugal force vs speed

NOMENCLAURE:

a	=	Distance of pivot to center of spindle, mm
F_{theo}	=	Theoretical centrifugal force, kg
F_{act}	=	Actual centrifugal force, kg
g	=	Acceleration due to gravity, m/s ²
H	=	Height of governor, mm
h	=	Final height, mm
h'	=	Initial height, mm
L	=	Length of link, mm
N_{theo}	=	Theoretical speed of governor, RPM
N_{act}	=	Actual speed of governor, RPM
R	=	Radius of rotation, mm
w	=	Weight of ball, kg
X	=	Final height of Sleeve, mm
X'	=	Height of sleeve at N rpm, mm
X''	=	Initial reading of pointer on sleeve
ω	=	Angular velocity, rad/sec

CONCLUSION

From the above experiments, we study and calculate the centrifugal forces at different speeds of watt governor and hence plotted the graphs.

HARTNELL GOVERNOR

A Hartnell governor is a spring loaded governor as shown in Fig 2. It consists of two bell crank levers pivoted at the points O, O to the frame. The frame is attached to the governor spindle and therefore rotates with it. Each lever carries a ball at the end of the vertical arm OB and a roller at the end of the horizontal arm OR. A helical spring in compression provides equal downward forces on the two rollers through a collar on the sleeve. The spring force may be adjusted by screwing a nut up or down on the sleeve.

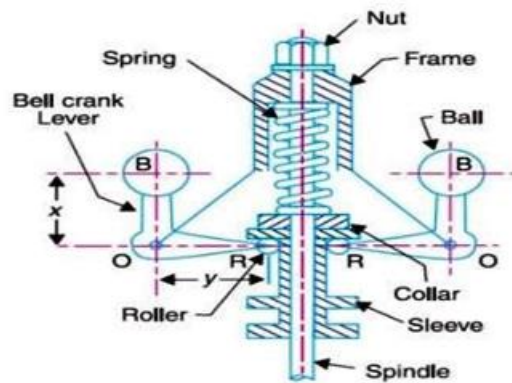
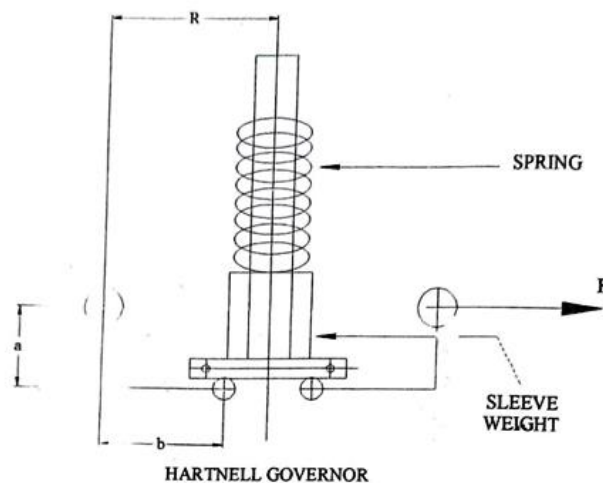

Fig.2 Hartnell governor

HARTNELL GOVERNOR



OBSERVATIONS AND CALCULATIONS

$$a = 75\text{mm}$$

$$b = 130\text{mm}$$

$$R' = 195\text{mm}$$

$$g = 9.81\text{m/sec}^2$$

$$w = 0.74\text{Kg}$$

$$W_1 = 2.120\text{Kg}$$

$$W_2 = 0.763\text{Kg}$$

OBSERVATION TABLE

$$X'' = \dots\dots\dots\text{mm}$$

Sl no	X' (mm)	N _{act} (R.P.M)
1		
2		
3		
4		

CALCULATIONS

$$X = (X' - X'') = \text{_____ mm}$$

$$R = \left(R' + X \times \frac{a}{b} \right) = \text{_____ mm}$$

$$F_c = \frac{w \times R \times \omega^2}{g \times 1000} = \text{_____ kg}$$

$$\omega = \frac{2\pi N_{act}}{60} = \text{_____ rad/sec}$$

$$S = \left(2 \times F_c \times \frac{a}{b} \right) - W = \text{_____ kg}$$

$$s = 2 \times \left(\frac{a}{b} \right)^2 \times \left(\frac{F_c}{R - R'} \right) = \text{_____ kg/mm}$$

If $\omega = 0$ then $F_c = 0$

$$s = 2 \times \left(\frac{a}{b} \right)^2 \times \left(\frac{F_c}{R - R'} \right) = \text{_____ kg/mm}$$

Sl no	N _{actual} in rpm	Lift /height in (mm)	Centrifugal force (F _{act}) in Kg
1			
2			
3			

Plot the following graphs

1. Height of sleeve lift vs Speed
2. Centrifugal force vs speed

CONCLUSION

From the above experiments, we study and calculate the centrifugal forces at different speeds of hartnell governor and hence plotted the graphs.

PORTER GOVERNOR

The Porter governor is a modification of a Watt's governor, with central load attached to the sleeve as shown in Fig 3. The load moves up and down the central spindle. This additional downward force increases the speed of revolution required to enable the balls to rise to any predetermined level.

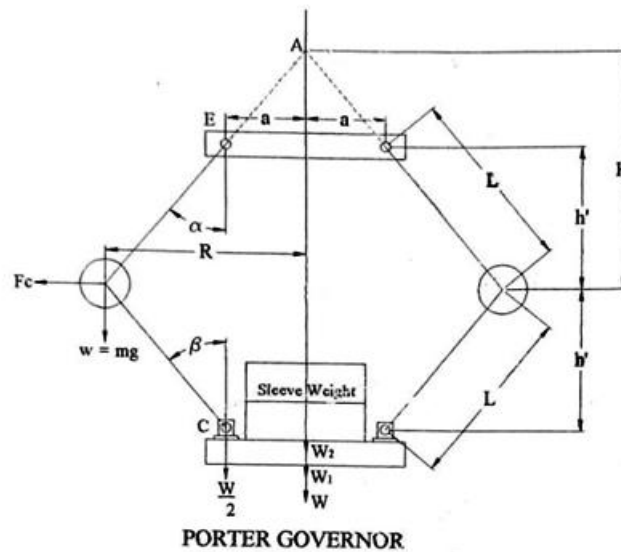
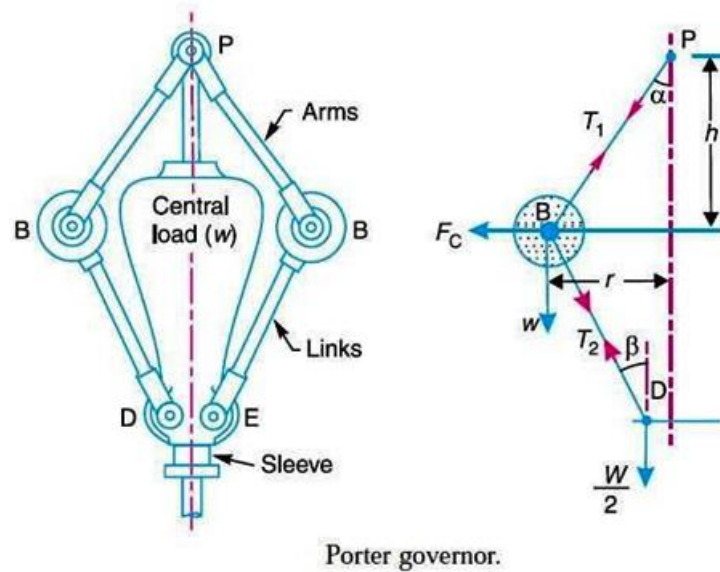

OBSERVATIONS AND CALCULATIONS

$$a = 42\text{mm}$$

$$L = 122\text{mm}$$

$$h' = 112\text{mm}$$

$$g = 9.81\text{m/sec}^2$$

$$w = 0.750\text{Kg}$$

$$W_1 = 2.120\text{Kg}$$

$$W_2 = 0.763\text{Kg}$$

$$W_3 = 0.165\text{Kg}$$

OBSERVATION TABLE

$$X'' = \dots\dots\dots\text{mm}$$

Sl no	X' (mm)	N_{act} (R.P.M)
1		
2		
3		
4		

CALCULATION

$$X = (X' - X'') = \text{_____ mm}$$

$$h = \left\{ h' - \left(\frac{X}{2} \right) \right\} = \text{_____ mm}$$

$$\alpha = \cos^{-1} \left(\frac{h}{L} \right) = \text{_____}$$

$$H = \left\{ \left(\frac{a}{\tan \alpha} \right) + h \right\} = \text{_____ mm}$$

$$R = \{ a + (L \sin \alpha) \} = \text{_____ mm}$$

$$F_{act} = \frac{W \times R \times \omega^2}{g \times 1000} = \text{_____ kg}$$

$$\omega = \frac{2 \times \pi \times N}{60} = \text{_____ rad/sec}$$

$$N_{theo} = \frac{60}{2\pi} \sqrt{\left(\frac{w+W}{w} \times \frac{g \times 1000}{H} \right)} = \text{_____ RPM}$$

$$F_{theo} = \left[w + \frac{W}{2} (1+k) \right] \tan \alpha = \text{_____ kg}$$

Or $k=1$

$$F_{theo} = [(w+W) \times \tan \alpha] = \text{_____ kg}$$

Sl no	N actual in rpm	Lift /height in (mm)	Centrifugal force (F_{act}) in Kg
1			
2			
3			

Plot the following graphs

1. Height of sleeve lift vs Speed
2. Centrifugal force vs speed

NOMENCLAURE:

a = Distance of pivot to center of spindle, mm

F_{theo} = Theoretical centrifugal force, kg

F_{act} = Actual centrifugal force, kg

GC = Displacement between points G and C of lower link, mm

g = Acceleration due to gravity, m/s^2

H = Height of governor, mm

h = Final height, mm

h' = Initial height, mm

L = Length of link, mm

N_{the} = Theoretical speed of governor, R.P.M

N_{act} = Actual speed of governor, R.P.M

R = Radius of rotation, mm

w = Weight of ball, kg

W_1 = Weight of cast iron sleeve, kg

W_2 = Dead weight applied on sleeve, kg

W_3 = Weight of arms on one side, kg

W = Total dead weight on sleeve, kg

X = Final height of Sleeve, mm

X' = Height of sleeve at N rpm

X'' = Initial reading of pointer on sleeve

ω = Angular velocity, rad/sec

a = Initial angle

y = Initial angle

CONCLUSION

From the above experiments, we study and calculate the centrifugal forces at different speeds of porter governor and hence plotted the graphs.

Practical Related Questions:-

1. What is the function of a governor?
2. How does it differ from that of a flywheel?
3. State the different types of governors.
4. What is the difference between centrifugal and inertia type governors?
5. Explain the term height of the governor.
6. What are the limitations of a Watt governor?
7. What is the stability of a governor?
8. Define the Sensitiveness of governor.

EXPERIMENT NO 2

AIM OF THE EXPERIMENT:-Study & demonstration of static balancing apparatus.

OBJECTIVES:-After performing the experiment students will be able to

- i) Explain the need of balancing.
- ii) Calculate the position of balancing mass.

APPARATUS REQUIRED:

SL NO	Equipment	Specification	Quantity
01	Static balancing Apparatus		
02	Blocks of different weight		

THEORY: -

The term “static” dates back to the days before sophisticated balancing machines were available to measure unbalance static balance is where the main axis is displaced only parallel to the shaft axis. The un-balance is correct in one axial plane. When machines are under unbalanced forces the load is not transmitted equally among different parts of machine. Due to improper distribution, the bearing friction is very high, shaft may fail, and vibration and noise are created. So balancing of machine is very essential. When net force acting on the machine is zero, i.e. the machine is statically balanced.

Static balancing

A system of rotating masses is said to be in static balance if the combined mass centre of the system lies on the axis of rotation. Whenever a certain mass is attached to a rotating shaft, it exerts some centrifugal force, whose effect is to bend the shaft and to produce vibrations in it. In order to prevent the effect of centrifugal force, another mass is attached to the opposite side of the shaft. The process of providing the second mass in order to counteract the effect of the centrifugal force of the first mass is called balancing of rotating masses.

Dynamic balancing

The masses are subjected to centrifugal forces when the shaft is rotating. Two conditions must be satisfied if the shaft is not to vibrate as it rotates:

- 1- There must be no out of balance centrifugal force trying to deflect the shaft.
- 2- There must be no out of balance moment or couple trying to twist the shaft. If these conditions are not fulfilled, the shaft is not dynamically balanced.

PROCEDURE:-

Remove the belt, the value of weight for each block is determined by clamping each block in turn on the shaft and with the cord and container system suspended over the protractor disc, the number of steel balls, which are of equal weight are placed into one of the containers to exactly balance the blocks on the shaft. When the block becomes horizontal, the number of balls N will give the value of wt. for the block. For finding out m.r during static balancing proceed as follow:

1. Remove the belt.
2. Screw the combined hook to the pulley with groove. This pulley is diff. than the belt pulley.
3. Attached the cord end of the pans to above combined hook.
4. Attached the block no.-1 to the shaft at any convenient position and in vertical downward direction.
5. Put steel balls in one of the pans till the blocks starts moving up. (upto horizontal position).
6. Number of balls gives the m.r value of block-1. Repeat this for 2-3 times and find the average no. of balls.
7. Repeat the procedure for other blocks.

OBSERVATIONS:

Sl.no	Block no	No of steel balls in left pan	No of steel balls in right pan	Average no of steel balls (m.r value)

RESULT:

CONCLUSION: Hence we successfully calculate the position of balancing mass.

Practical Related Questions:-

- i) Write down the importance of balancing.
- ii) Why rotating masses are to be dynamically balanced?
- iii) Differentiate between static and dynamic balancing
- iv) Can a single cylinder engine be fully balanced? Why?
- v) Whether grinding wheels are balanced or not? If so why?

EXPERIMENT NO 3

AIM OF THE EXPERIMENT:- To determine the present distribution of lubricating oil at various load and speed of a Journal Bearing.

INTRODUCTION

Journal Bearing Apparatus is designed on the bearing action used in practice. To formulate the bearing action accurately in mathematical terms is a more complex job. However, one can visualize the pattern of bearing pressure distribution due to the hydrodynamic action with the help of experimental rig. This helps to understand the subject properly. The experimental rig consists of a small journal bearing as shown in Fig. This apparatus helps to demonstrate and study the effect of important variables such as speed, viscosity and load, on the pressure distribution in a Journal Bearing.

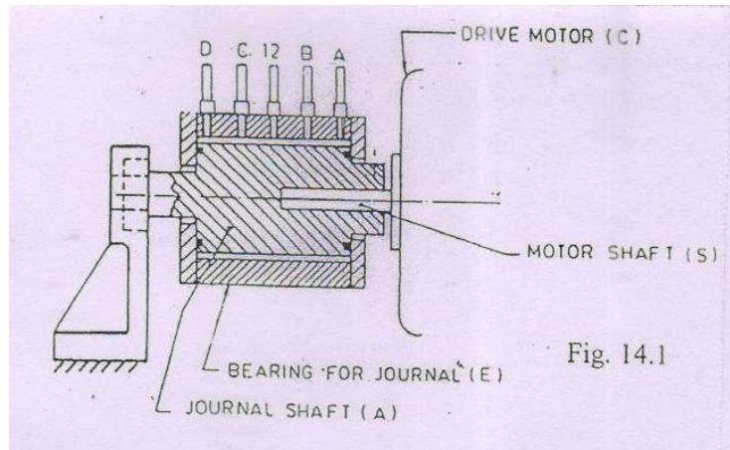

DESCRIPTION

The apparatus is illustrated in fig. It consists of a Brass bearing mounted freely on steel Journal shaft (A). This journal shaft is fixed directly on to a motor shaft (S). A Dimmer stat finely controls the speed of the DC motor. The Journal Bearing (E) has twelve (No.1 to 12) equispaced of 300 pressure tapings around its circumference, and two No, 13, 14 additional axial pressure tapings are positioned on the topside of the journal bearing. The two sides of bearing are closed with two MS plates and sealed with gasket packing to avoid leakage. Balancing weights are provided to maintain the bearing in horizontal position while taking the readings. Both the weights can be adjusted freely along the rod. Oil film pressures are indicated in 14-tubes

manometer frame and readings directly in head of oil. Clear flexible tubes are fixed on the manometer frame and connected to the tapings spaced around bearing and thus permit the bearing to turn freely. The oil reservoir can be adjusted at required height and is connected to the bearing by a flexible plastic tube. From this reservoir oil enters the bearing through this plastic tube.

SPECIFICATIONS

- Diameter of Journal = $2r = 52.5$ mm.
- Diameter of bearing = $2R = 50$ mm (with 12 radial tapings and 2 axial tapings).
- Bearing width (L) = 90mm. o Motor speed = 800 -1000rpm (variable speed – DC).
- Motor control. Electronic DC Controller for motor speed control.
- Manometer frame with 14 tubes of 240cm. Height with scales and adjustable oil supply tank.
- Recommended oil = Lubricating oil SAE 30.
- Supply required AC single phase 230v.50Hz stabilized.
- r = Radius of Journal.
- δ = Radial clearance (R-r) = (52.5-50) = 2.5 mm.
- e = Eccentricity 00' between the center of the bearing & center of journal 2.5mm.
- Eccentricity ratio = e/δ or $e/n\delta = 2.5/2.5 = 1$
- μ = Viscosity of oil.
- R = Radius of journal bearing.
- θ = Angle between the one of center and the position of which is to measured.
- h = Film thickness =2.5 mm

THEORY OF JOURNAL BEARINGS

The mathematical analysis of the behavior of a journal in a bearing falls into two distinct categories:

1. Hydrodynamics of fluid flow between plates.
2. Journal bearing analysis where the motion of the journal in the oil films is considered.

According to the equation the Sommerfield pressure function (when the velocity of the eccentricity and the whirl speed of the journal are both zero) is given by:

$$S_o = \left[\frac{r}{c} \right]^2 \left[\frac{\mu N}{P} \right] K_w \times 10^{-6}$$

When K_w correction factor for side leakage from graph. Where 'p' is the pressure of the oil film at the point measured anticlockwise from the line of common centers (00°) NOTE: Some books on lubrication give the Sommerfield function with a negative sign for 'n'. This is true if it is measured from the point of minimum thickness of the oil film.

RANGE OF EXPERIMENTS: Determine the pressure distribution in the oil film of the bearing for various speeds and

- a) Plot the polar pressure curve for various speeds by graphical method.
- b) Calculate by using the Sommerfield pressure equation for each speed
- c)

$$S_o = \left[\frac{r}{c} \right]^2 \left[\frac{\mu N}{P} \right] K_w \times 10^{-6}$$

EXPERIMENTAL PROCEDURE:

1. Fill the oil tank by using SAE 30 lubricating oil under test and position the tank at the desired height (up to 1.5 liter oil).
2. Drain out the air from the tubes on the manometer by removing the tubes from manometer.
3. Check that some oil sea page is there (Sea page of oil is necessary for cooling purpose).
4. Check the direction of rotation and increase the speed of the motor slowly.
5. Set the speed and let the journal run for about an 2 minutes until the oil in the bearing is warmed up and check the steady oil levels at various tapings.

6. Add the required loads and adjust the balancing weights, on the rod to maintain the horizontal levels position.
 7. When the manometer levels are settled down, take the pressure readings on 1-14 manometer tubes. For circumferential and axial pressure distribution.
 8. Repeat the experiment for various speed and loads.
 9. After the test is over set dimmer to zero position and switch off the main supply.
 10. Keep the oil tank at lower most position so that there will be no leakage in the idle period.
- GRAPHS: Graph to be plotted for pressure head of oil above supply head in cm of oil, of the oil film. The angular interval positions are at angular intervals of 30 measured in anticlockwise, commencing with position marked.

SAMPLE OF CALCULATIONS TO FIND SOMMERFIELD EQUATION

TABLE OF READINGS:

Tube No. Radial pressure point	LOAD in Kg	Speed	Supply head in mm of oil, Ps	Pressure at different points, Pa	Actual pressure ($P_s - P_a$)
1	1	800	40	45.4	-5.4
2	1	800	40	54.0	-14
3	1	800	40	57.6	-17.6
4	1	800	40	55.8	-15.8
5	1	800	40	53.1	-13.1
6	1	800	40	50.4	-10.4
7	1	800	40	47.3	-7.3
8	1	800	40	45.1	-5.1
9	1	800	40	42.7	-2.7
10	1	800	40	40.3	-0.3
11	1	800	40	37.3	2.7
12	1	800	40	38.1	1.9
13	1	800	40	45.2	-5.2
14	1	800	40	44.8	-4.8

Reading from observation table:

For speed = 800 rpm

Pressure at point 1 = 40 cm of oil

Sommerfeld equation is given by

$$S_o = (r/c)^2 (\mu N/p) K_w \times 10^{-6}$$

Where,

c = radial clearance = 3 mm = 0.0025 m

r = radius of journal = 27.5 mm = 0.02625 m

μ = viscosity of oil = 400×10^{-3} NS/m²

N = Speed of the journal = 800 rpm

p = bearing pressure in kg/mm² (MN/m²)

K_w = correction factor for side leakage

Calculation for p:

From manometer, Pressure = 40 cm of oil

$$\begin{aligned} \text{Conversion into m of water} &= 400 \times \text{Specific gravity of oil} \\ &= 400 \times 0.93 \text{ (from standard chart)} \\ &= 372 \text{ m of water} \end{aligned}$$

$$\text{Conversion into Kg/cm}^2 = 372 / 10 = 37.2 \text{ Kg/cm}^2$$

{Where 1 kg/cm² = 10 m of water}

$$\text{Conversion into Kg/mm}^2 = 372 / 100 = 3.72 \text{ Kg/mm}^2$$

{Where 1 Kg/mm² = 100 Kg/cm²}

To obtain KW from graph,

Refer graph given (fig. 1)

Calculation for B/L:

$$\text{From table } B = 2 \times \pi \times r \times (\beta/360)$$

(Where β = angle of radial point1 = 30)

$$= 2 \times \pi \times 0.02625 \times (30/360)$$

$$= 0.0137 \text{ m}$$

$$L = 0.090 \text{ m}$$

$$\text{Therefore } B/L = 0.0137/0.09 = 0.152$$

From graph for $B/L = 0.152$ and $h_o/c = 0.6$

Correction factor $K_w = 0.85$

Therefore substituting above in Sommerfeld equation

$$\begin{aligned} S_o &= (r/c)^2 (\mu N/p) K_w \times 10^{-6} \\ &= (0.02625/0.0025)^2 \times \{(400 \times 10^{-3} \times 800)/0.372\} \times 0.85 \times 10^{-6} \\ &= \underline{80,430 \times 10^{-6}} \text{ in s/min} \end{aligned}$$

Note: Similarly calculate for all the pressure points to get different Sommerfeld number.

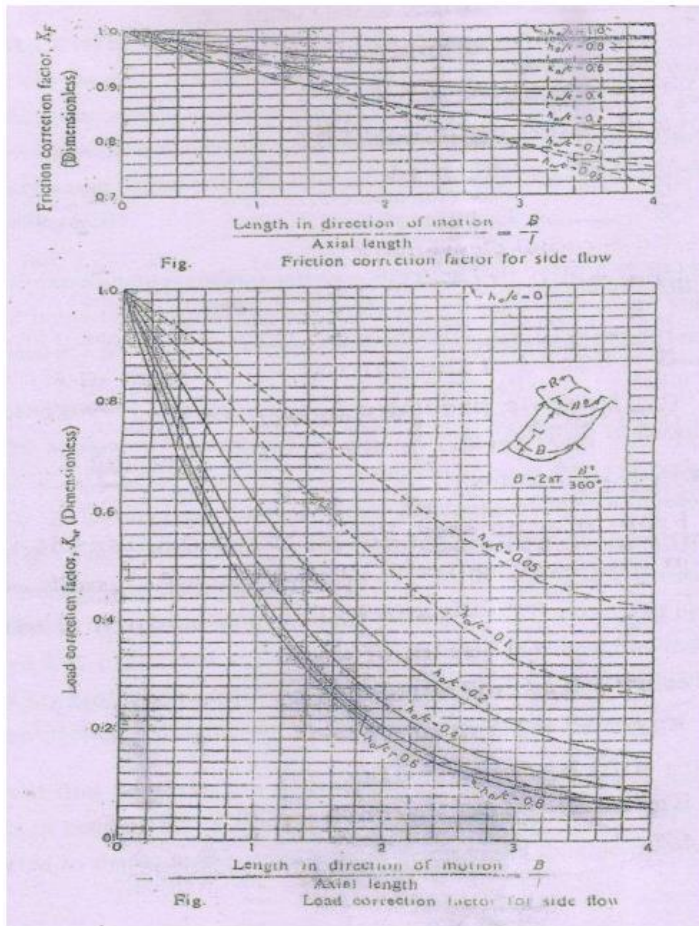

RESULT:

Practical Related Questions:-

1. Explain working of journal bearing.
2. What is the need of bearing? State its applications.
3. Give examples of some bearing material.
4. What is the name of the lubricating oil used in this experiment?

EXPERIMENT NO 4

AIM OF THE EXPERIMENT:- Study of different types of Cam and followers

INTRODUCTION

Cam - A mechanical device used to transmit motion to a follower by direct contact. Where Cam – driver member, Follower - driven member.

cam is a rotating machine element which gives reciprocating or oscillating motion to another element known as follower. The cam and the follower have a line contact and constitute a higher pair.

The cams are usually rotated at uniform speed by a shaft, but the follower motion is predetermined and will be according to the shape of the cam. The cam and follower is one of the simplest as well as one of the most important mechanisms found in modern machinery today.

APPLICATIONS:

The cams are widely used for operating the inlet and exhaust valves of Internal combustion engines, automatic attachment of machineries, paper cutting machines, spinning and weaving textile machineries, feed mechanism of automatic lathes.

Example of cam action

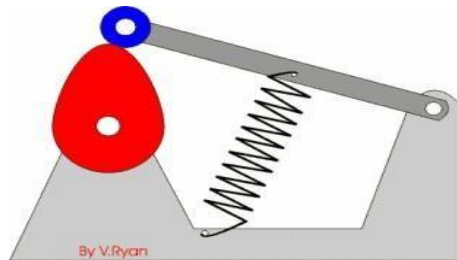

CLASSIFICATION OF FOLLOWERS

1. Based on surface in contact. (Fig.1)

(a) **Knife edge follower.** When the contacting end of the follower has a sharp knife edge, it is called a knife edge follower, as shown in Fig. 1 (a). The sliding motion takes place between the contacting surfaces (i.e. the knife edge and the cam surface). It is seldom used in practice because the small area of contacting surface results in excessive wear. In knife edge followers, a considerable side thrust exists between the follower and the guide.

(b) **Roller follower.** When the contacting end of the follower is a roller, it is called a roller follower, as shown in Fig. 1 (b). Since the rolling motion takes place between the contacting surfaces (i.e. the roller and the cam), therefore the rate of wear is greatly reduced. In roller followers also the side thrust exists between the follower and the guide. The roller followers are extensively used where more space is available such as in stationary gas and oil engines and aircraft engines

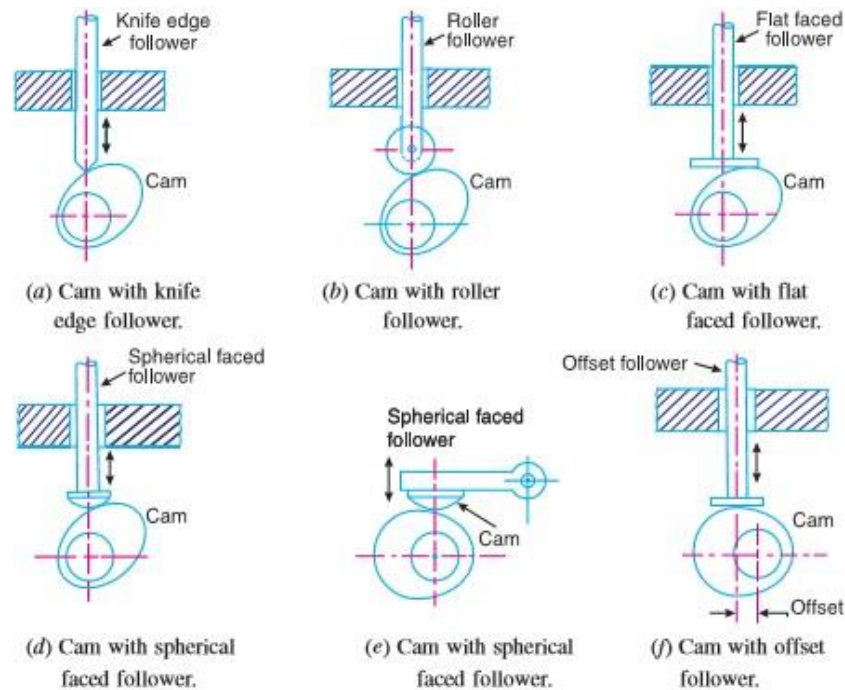

Fig. 1.Types of followers

(c) **Flat faced or mushroom follower.** When the contacting end of the follower is a perfectly flat face, it is called a flat-faced follower, as shown in Fig. 1 (c). It may be noted that the side thrust between the follower and the guide is much reduced in case of flat faced followers. The only side thrust is due to friction between the contact surfaces of the follower and the cam. The relative motion between these surfaces is largely of sliding nature but wear may be reduced by off-setting the axis of the follower, as shown in Fig. 1 (f) so that when the cam rotates, the follower also rotates about its own axis. The flat faced followers are generally used where space is limited such as in cams which operate the valves of automobile engines.

(d) **Spherical faced follower.** When the contacting end of the follower is of spherical shape, it is called a spherical faced follower, as shown in Fig. 1 (d). It may be noted that when a flat-faced follower is used in automobile engines, high surface stresses are produced. In order to minimize these stresses, the flat end of the follower is machined to a spherical shape

2. According to the motion of the follower

(a) **Reciprocating or translating follower.** When the follower reciprocates in guides as the cam rotates uniformly, it is known as reciprocating or translating follower. The followers as shown in Fig. 1 (a) to (d) are all reciprocating or translating followers

(b) **Oscillating or rotating follower.** When the uniform rotary motion of the cam is converted into predetermined oscillatory motion of the follower, it is called oscillating

or rotating follower. The follower, as shown in Fig 1 (e), is an oscillating or rotating follower.

3. According to the path of motion of the follower

(a) **Radial follower.** When the motion of the follower is along an axis passing through the centre of the cam, it is known as radial follower. The followers, as shown in Fig. 1 (a) to (e), are all radial followers.

(b) **Off-set follower.** When the motion of the follower is along an axis away from the axis of the cam centre, it is called off-set follower. The follower, as shown in Fig. 1 (f), is an off-set follower.

CLASSIFICATION OF CAMS

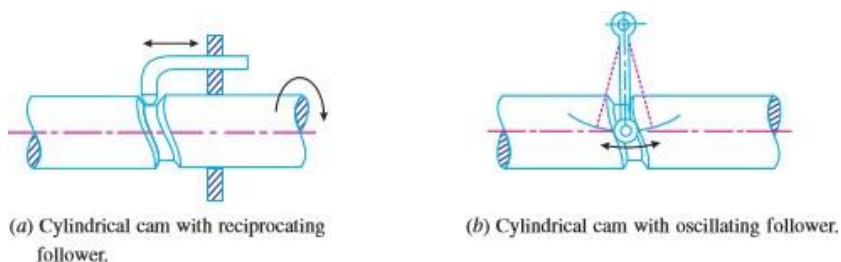

Fig 2 cams

(a) **Radial or disc cam.** In radial cams, the follower reciprocates or oscillates in a direction perpendicular to the cam axis. The cams as shown in Fig. 1 are all radial cams.

(b) **Cylindrical cam.** In cylindrical cams, the follower reciprocates or oscillates in a direction parallel to the cam axis. The follower rides in a groove at its cylindrical surface. A cylindrical grooved cam with a reciprocating and an oscillating follower is shown in Fig. 2 (a) and (b) respectively

Terms Used in Radial Cams Fig. 3 shows a radial cam with reciprocating roller follower. The following terms are important in order to draw the cam profile.

1. Base circle. It is the smallest circle that can be drawn to the cam profile.
2. Trace point. It is a reference point on the follower and is used to generate the pitch curve. In case of knife edge follower, the knife edge represents the trace point and the pitch curve corresponds to the cam profile. In a roller follower, the centre of the roller represents the trace point.

3. Pressure angle. It is the angle between the direction of the follower motion and a normal to the pitch curve. This angle is very important in designing a cam profile. If the pressure angle is too large, a reciprocating follower will jam in its bearings.
4. Pitch point. It is a point on the pitch curve having the maximum pressure angle.
5. Pitch circle. It is a circle drawn from the centre of the cam through the pitch points.
6. Pitch curve. It is the curve generated by the trace point as the follower moves relative to the cam. For a knife edge follower, the pitch curve and the cam profile are same whereas for a roller follower, they are separated by the radius of the roller.
7. Prime circle. It is the smallest circle that can be drawn from the centre of the cam and tangent to the pitch curve. For a knife edge and a flat face follower, the prime circle and the base circle are identical. For a roller follower, the prime circle is larger than the base circle by the radius of the roller.
8. Lift or stroke. It is the maximum travel of the follower from its lowest position to the topmost position.

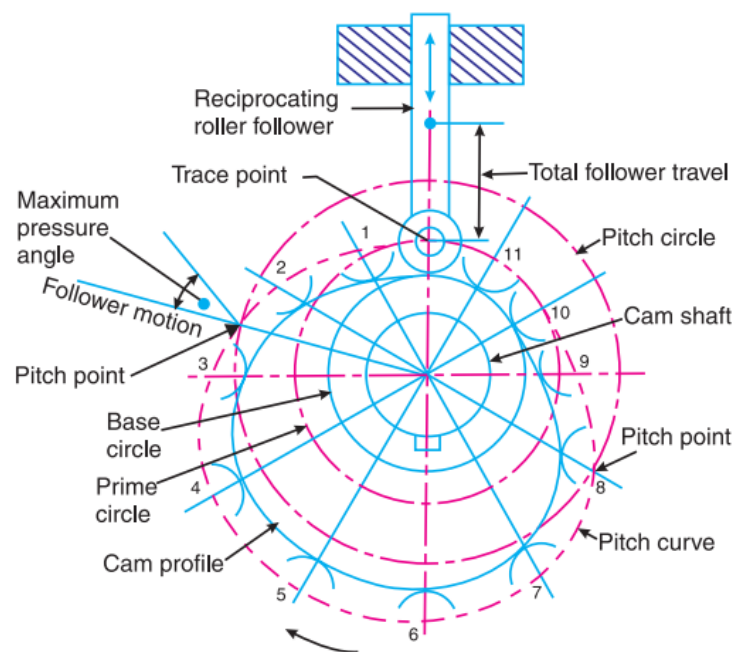

Figure 3

Practical Related Questions:-

1. What are the different motions of the follower?
2. Define trace point in the study of cams.
3. Define pressure angle with respect to cams.
4. Define undercutting in cam. How is occurs?
5. Define Trace point.

EXPERIMENT NO 6

AIM OF THE EXPERIMENT:- Determination of the thickness of ground M.S flat to an accuracy of 0.02mm using Vernier Caliper.

APPARATUS REQUIRED:

SL.NO	Name of the Items	Specification	Quantity
01.	Vernier caliper		
02.	M.S Flat		

THEORY:

Vernier Caliper

The Vernier caliper has one 'L' shaped frame with a fixed jaw on which Vernier scale is attached.

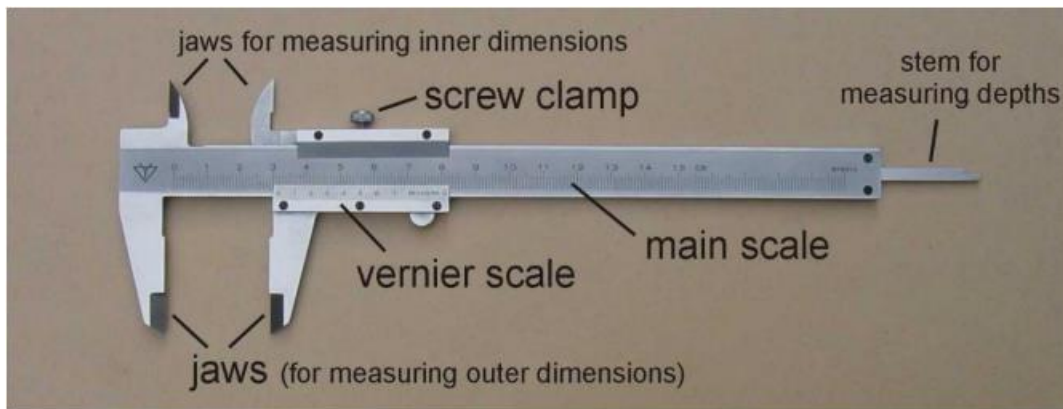

Figure 1 Vernier Instruments

The principle of vernier is that when two scales or divisions slightly different in size are used, the difference between them can be utilized to enhance the accuracy of measurement. The vernier calliper essentially consists of two steel rules and these can slide along each other. One of the scales, i.e., main scale is engraved on a solid L-shaped frame. One end of the frame contains a fixed jaw which is shaped into a contact tip at its extremity. The three elements of vernier caliper, viz, beam, fixed jaw, and sliding jaw permit substantial improvements in the commonly

used measuring techniques over direct measurement with line graduated rules. The alignment of the distance boundaries with the corresponding graduations of the rule is ensured by means of the positive contact members (the jaws of the caliper gauges). The datum of the measurement can be made to coincide precisely with one of the boundaries of the distance to be measured. The movable jaw achieves positive contact with the object boundary at the opposite end of the distance to be measured. The closely observable correspondence of the reference marks on the slide with a particular scale value significantly reduces the extent of read-out alignment errors.

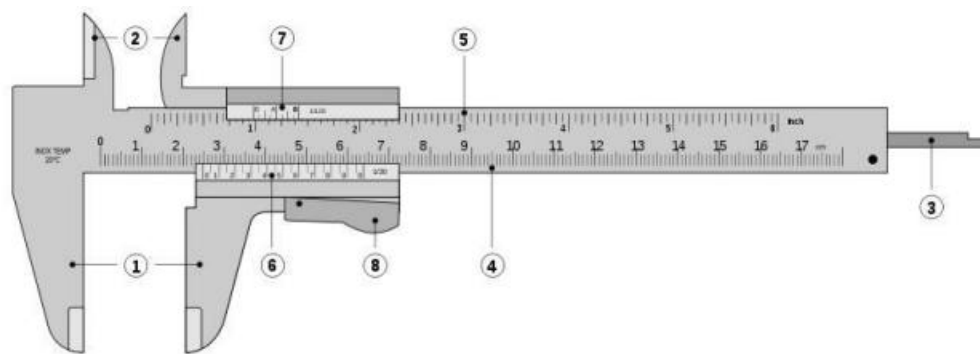

Figure 2 Vernier Instruments

A sliding jaw which moves along the guiding surface provided by the main scale is coupled to a vernier scale. The sliding jaw at its left extremity contains another measuring tip. When two measuring tip surfaces are in contact with each other, scale shows zero reading. The finer adjustment of the movable jaw can be done by the adjusting screw. First the whole movable jaw assembly is adjusted so that the two measuring tips just touch the part to be measured. Then lock nut is tightened. Final adjustment depending upon the sense of correct feel is made by the adjusting screw. The movement of adjusting screw makes the part containing locking nut and sliding jaw to move, as the adjusting screw rotates on a screw which is in a way fixed to the movable jaw. After final adjustment has been made, the locking nut is also tightened and the reading is noted down. The measuring tips are so designed as to measure inside as well as outside dimensions.

1. Outside jaws: used to measure external diameter or width of an object
2. Inside jaws: used to measure internal diameter of an object
3. Depth probe: used to measure depths of an object or a hole

4. Main scale: gives measurements of up to one decimal place (in cm).
5. Main scale: gives measurements in fraction (in inch)
6. Vernier gives measurements up to two decimal places (in cm)
7. Vernier gives measurements in fraction (in inch)
8. Retainer: used to block movable part to allow the easy transferring a measurement

PROCEDURE

1. The list count is to be determined
2. $L.C = 1 \text{ main scale division} - 1 \text{ vernier scale division}$
3. The work piece is placed between the jaws of vernier calliper.
4. The reading on the main scale which is just behind the first vernier scale division is noted as main scale reading (MSR)
5. The division on the vernier scale which coincide with the line on main scale is noted down as vernier coincidence (VSD)
6. The thickness (MD) can be calculated using the given formula Least Count is the smallest length that can be measured accurately and is equal to the difference between a main scale division and a Vernier scale division.

LEAST COUNT = 1 Main scale division – 1 Vernier scale division

OBSERVATION:-

50 V.S.D = 49 M.S.D

1 V.S.D = 49/50 M.S.D

1 M.S.D = 1mm.

Least count = 1 M.S.D - 1 V.S.D = 1mm - 49/50 = 0.02mm.

$$MD = [MSR + (VSD \times LC)]$$

MD-Measured Dimension

MSR-Main Scale Reading

VSD-Vernier Scale Division

LC-Least Count

TABULATION:

Least Count of vernier = 0.02mm Vernier Calliper Reading 'mm'					Remark
Sl no	MSR	VSD	VSR=VSDXLC	MD=MSR +VSR	
1					
2					
3					
4					
5					

RESULT:

CONCLUSION: The precision measuring instrument vernier calliper is studied and thickness of ground M.S flat is measured to an accuracy of 0.02mm using Vernier Caliper.

Practical Related Questions:-

1. What is least count?
2. State different parts of vernier caliper.
3. What is the material of vernier caliper?
4. Which one is smaller M.S. div. or V.S. div.?
5. What is meant by zero error (Z.E.)?

EXPERIMENT NO 7

AIM OF THE EXPERIMENT:- Determination of diameter of a cylindrical component to an accuracy of 0.01mm using micrometer.

APPARATUS REQUIRED:

SL.NO	Name of the Items	Specification	Quantity
01.	Outside Micrometer		
02.	Cylindrical component		

THEORY

Micrometer The micrometer screw gauge essentially consists of an accurate screw having about 10 or 20 threads per cm and revolves in a fixed nut. The end of the screw forms one measuring tip and the other measuring tip is constituted by a stationary anvil in the base of the frame. The screw is threaded for certain length and is plain afterwards. The plain portion is called sleeve and its end is the measuring surface. The spindle is advanced or retracted by turning a thimble connected to the spindle. The spindle is a slide fit over the barrel and barrel is the fixed part attached with the frame.. A lock nut is provided for locking a dimension by preventing motion of the spindle.

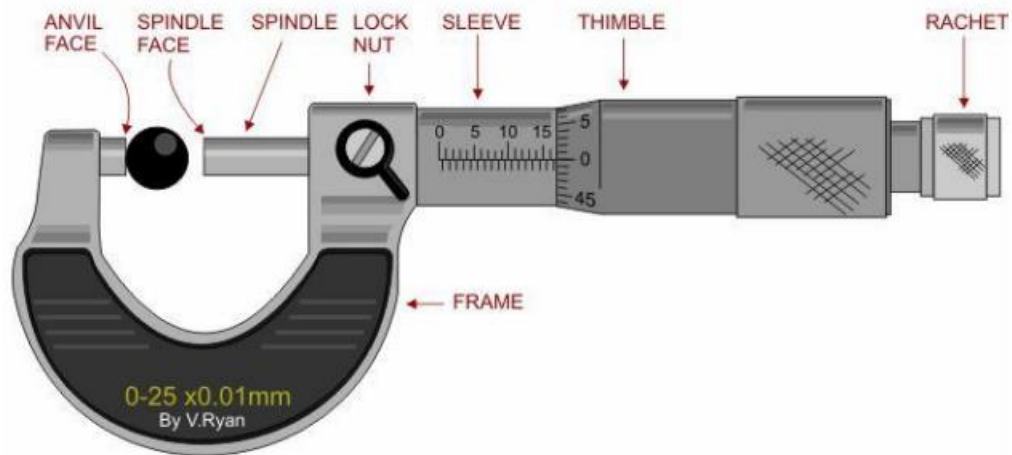

Ratchet stop is provided at the end of the thimble cap to maintain sufficient and uniform measuring pressure so that standard conditions of measurement are attained. Ratchet stop consists of an overriding clutch held by a weak spring. When the spindle is brought into contact with the work at the correct measuring pressure, the clutch starts slipping and no further movement of the spindle takes place by the rotation of ratchet. In the backward movement it is positive due to shape of ratchet.

LEAST COUNT = Pitch scale division / Number of threads Pitch scale division = Distance moved / number of rotation

USES:-

1. Outside micrometer is used to measure the diameter of solid cylinder.
2. Inside micrometer is used to measure the internal diameters of hollow cylinders and spheres.

PROCEDURE:-

1. The micrometer is checked for Zero error
2. The given component is held between the face of the anvil and the spindle
3. The spindle is moved by rotating the thimble until the anvil and spindle touches the cylindrical surface of the component
4. Final adjustment is made by ratchet. The main scale reading and thimble scale reading is noted
5. Two more reading are taken at different place of the component
6. The readings are tabulated and calculated.

OBSERVATION:-

Least count:- The distance moved by the spindle during one rotation of thimble is 0.5mm.
Movement of one division of the Thimble = $0.5 \times 1/50 = 0.01\text{mm}$.

TABULATION:-

Least Count of micrometer= 0.01mm								
Micrometer Reading 'mm'								
SL.NO	Barrel Reading(x)	Thimble Division	Least Count	Thimble(y) Reading L.C x T.D	X +Y	Reading	Digital micrometer Reading	Error
01								
02								
03								
04								
05								

RESULT:

CONCLUSION: The precision measuring instrument micrometer is studied and diameter of a cylindrical component is measured using an accuracy of 0.01mm using micrometer.

Practical Related Questions:-

1. What is meant by “gauge”?
2. How the L.C. of a screw gauge is found?
3. What is back lash error?
4. Does the diameter of the screw depend on temperature?
5. What are “precision instrument”?

EXPERIMENT NO 8

AIM OF THE EXPERIMENT:- Determine the heights of gauge blocks or parallel bars to accuracy of 0.02mm using Vernier height gauge.

APPARATUS REQUIRED:

SL.NO	Name of the Items	Specification	Quantity
01.	Vernier height gauge		
02.	Parallel bars		
03.	Gauge blocks		

THEORY

Vernier height gauge Vernier height gauge is similar to vernier calliper but in this instrument the graduated bar is held in a vertical position and it is used in conjunction with a surface plate.

CONSTRUCTION: A vernier height gauge consists of

1. A vernier height gauge consists of A finely ground and lapped base. The base is massive and robust in construction to ensure rigidity and stability.
2. A vertical graduated beam or column supported on a massive base.
3. Attached to the beam is a sliding vernier head carrying the vernier scale and a clamping screw.
4. An auxiliary head which is also attached to the beam above the sliding vernier head. It has fine adjusting and clamping screw.
5. A measuring jaw or a scribe attached to the front of the sliding vernier

USE.

The vernier height gauge is designed for accurate measurements and marking of vertical heights above a surface plate datum. It can also be used to measure differences in heights by taking the vernier scale readings at each height and determining the difference by subtraction. It can be used for a number of applications in the tool room and inspection department. The important features of vernier height gauge are:

All the parts are made of good quality steel or stainless steel.

- The beam should be sufficiently rigid square with the base.

- The measuring jaw should have a clear projection from the edge of the beam at least equal to the projection of the base' from the beam.
- The upper and lower gauging surfaces of the measuring jaw shall be flat and parallel to the base.
- The scribe should also be of the same nominal depth as the measuring jaw so that it may be reversed.
- The projection of the jaw should be at least 25 mm

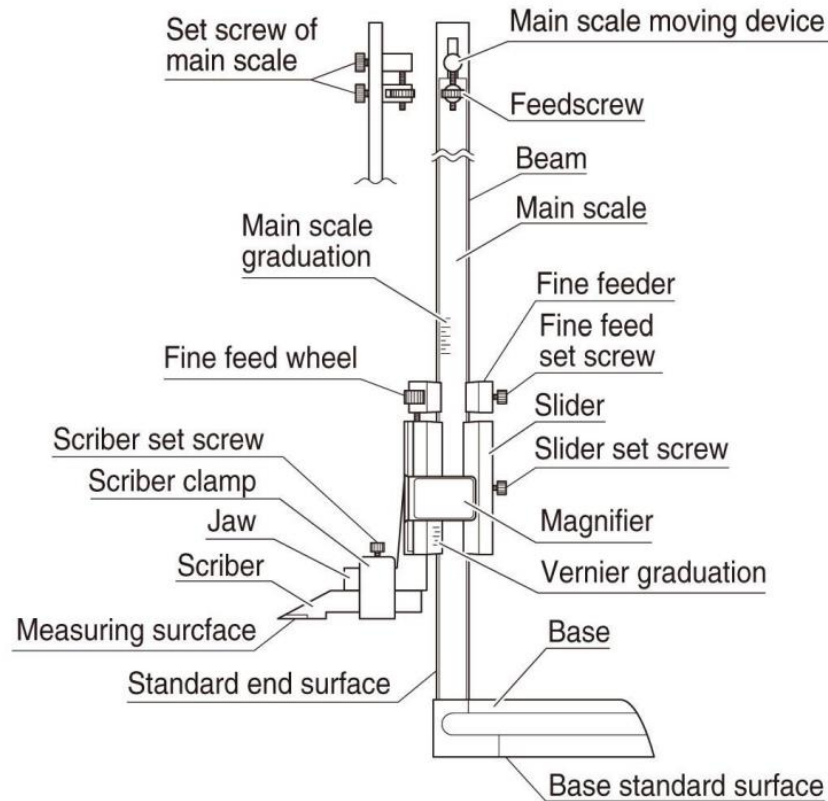

PROCEDURE

1. Clean the main scale, Vernier scale and measuring jaws of the Vernier Height gauge
2. The vernier height gauge is checked for zero error
3. Place the job in Surface plate.
4. Place the measuring jaw such that it touches the surface to be measured from the Smooth surface
5. Measure the main scale reading and Vernier scale coincidence of the Vernier Height gauge

OBSERVATION:-

50 V.S.D = 49 M.S.D
1 V.S.D = 49/50 M.S.D
1 M.S.D = 1mm.
Least count = 1 M.S.D - 1 V.S.D
= 1mm - 49/50
= 0.02mm

FORMULA

$$MD = [MSR + (VSC \times LC)]$$

- MD - Measured Dimension
- MSR - Main Scale Reading
- VSC - Vernier Scale Coincide
- LC - Least Count

TABULATION:

Least Count of vernier = 0.02mm Vernier height gauge Reading 'mm'				
Sl no	MSR	VSC	VSR = VSC × LC	MD = MSR + VSR
1				
2				
3				
4				
5				

RESULT:

CONCLUSION: The precision measuring instrument vernier height gauge is studied and thickness of mild steel flat specimen is measured.

Practical Related Questions:-

1. What is the least count of vernier height gauge?
2. State different parts of a vernier height gauge.
3. What is the material of vernier height gauge?
4. Briefly explain How to measure height of a specimen using vernier height gauge?

EXPERIMENT NO 9

AIM OF THE EXPERIMENT:- Determine the thickness of ground MS plates using slip gauges.

APPARATUS REQUIRED:

SL.NO	Name of the Items	Specification	Quantity
01.	M.S Plates		02
02.	Slip gauge		1box
03.	Surface Plate		01
04.	Vernier height gauge		01

THEORY:- Slip gauges or gauge blocks are universally accepted end standard of length in industry. These were introduced by Johnson, a Swedish engineer, and are also called as johanson gauges.

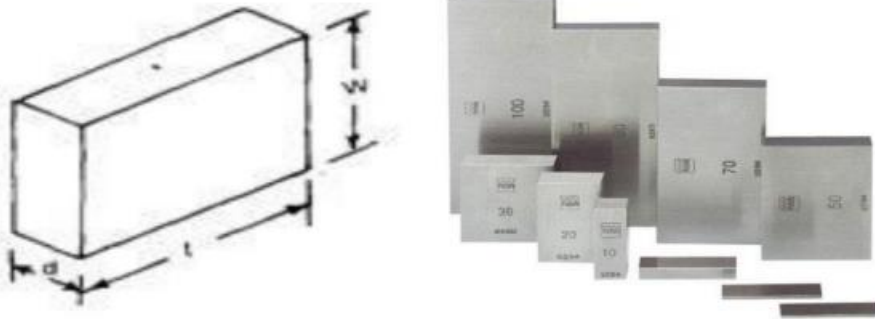

Slip gauges are rectangular blocks of high grade steel with exceptionally close tolerances. These blocks are suitably hardened through out to ensure maximum resistance to wear. They are then stabilized by heating and cooling successively in stages so that hardening stresses are removed, After being hardened they are carefully finished by high grade lapping to a high degree of finish, flatness and accuracy. For successful use of slip gauges their working faces are made truly flat and parallel. A slip gauge is shown in fig. Slip gauges are also made from tungsten carbide which is extremely hard and wear resistance.

The cross-sections of these gauges are 9 mm x 30 mm for sizes up to 10 mm and 9 mm x 35 mm for larger sizes. Any two slips when perfectly clean may be wrung together. The

dimensions are permanently marked on one of the measuring faces of gauge blocks. Gauge blocks are used for:

1. Direct precise measurement, where the accuracy of the work piece demands it.
2. For checking accuracy of vernier callipers, micrometers, and such other measuring instruments.
3. Setting up a comparator to a specific dimension.
4. For measuring angle of work piece and also for angular setting in conjunction with a sinebar.
5. The distances of plugs, spigots, etc. on fixture are often best measured with the slipgauges or end bars for large dimensions.
6. To check gap between parallel locations such as in gap gauges or between two mating parts.

PROCEDURE:-

1. At first we cleaned the surface of slip gauge.
2. Then we inserted the slip gauge for measuring the thickness by taking attention such that minimum number of slip gauges is used.
3. Then we removed the gauge from jobs.
4. We calculated the thickness by adding individual slip gauge reading which is mentioned on the surface of slip gauge.
5. In this way by repeating above procedure we took 5 reading.

For measuring the thickness of M.S plate by using set of 112 pieces.

Range in mm	Steps	No of pieces
1.005		01
1.001 to 1.009	0.001	09
1.01 to 1.49	0.01	49
05 to 24.5	0.05	49
25 to 100	25.00	04

TABULATION:-

SL .NO	Select the slip gauges	Select the slip	Select 2 nd	Select 3 rd	Select 4 th	Total reading	Average reading
01	1.005	1.002	1.37	1.5	0	4.8725	4.1515
02	1.0005	1.003	1.25	2	0	5.2535	
03	1.0005	1.001	1.15	1.2	0	4.1515	
04	1.0005	0.008	1.13	0.5	0	3.6385	
05	1.0005	1.008	1.45	2.5	0	5.9585	

CONCLUSION:-

From the above experiment we find the thickness of M.S plate by using the range of slip gauges.

EXPERIMENT NO 10

AIM OF THE EXPERIMENT:- Determination of angle of Machined surfaces of components using sine bar with slip gauges.

APPARATUS REQUIRED:

SL.NO	Name of the Items	Specification	Quantity
01.	One machined surface in any angle		01
02.	Sine bar	200mm	01
03.	Slip gauge box	(0-83) pcs	01 set

SINE PRINCIPLE AND SINE BARS

The sine principle uses the ratio of the length of two sides of a right triangle in deriving a given angle. It may be noted that devices operating on sine principle are capable of “self generation.” The measurement is usually limited to 45° from loss of accuracy point of view. The accuracy with which the sine principle can be put to use is dependent in practice, on some form of linear measurement. The sine bar in itself is not a complete measuring instrument. Another datum such as a surface plate is needed, as well as other auxiliary equipment, notably slip gauges, and indicating device to make measurements. Sine bars used in conjunction with slip gauges constitute a very good device for the precise measurement of angles. Sine bars are used either to measure angles very accurately or for locating any work to a given angle within very close limits. Sine bars are made from high carbon, high chromium, corrosion resistant steel, hardened, ground and stabilized.

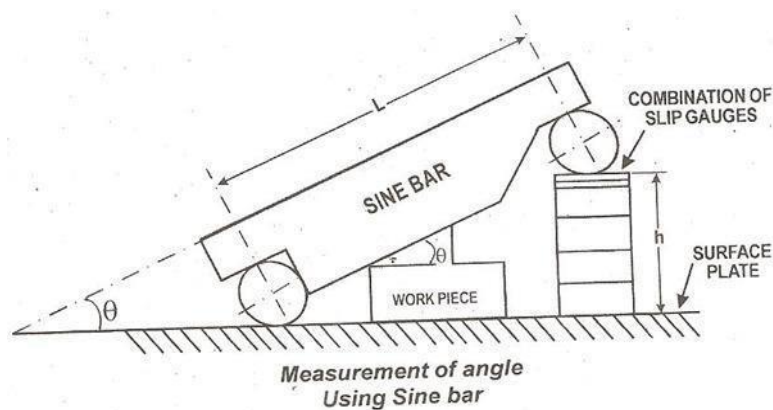

PROCEDURE

1. The given component is placed on the surface plate.
2. One roller of sine bar is placed on surface plate and bottom surface of sine bar is seated
3. The combination of slip gauges is inserted between the second roller of sine bar and the surface plate.
4. The angle of the component is then calculated by the formula given below

FORMULA:

$$\sin \theta = H/L$$

Where, H = (h1-h2) =Height of the slip gauge

L - Distance between the centres

TABULATION

SL.NO	h1 in mm.	h2 in mm.	h1-h2 in mm.	L in mm	Sin $\theta = h1-h2/L$ in(0)	$\theta = \sin^{-1}(h1-h2)/L$ in radian
1	3.25	1.5	1.75	200	1.75/200	5 radian=28.72

RESULT

Thus the angle in the work pieces were Determined using Sine bar

Angle measured in work piece ,1 =----- 'degree'

Angle measured in work piece ,2 =----- 'degree'