



LECTURE NOTES

SUBJECT-

UNDERGROUND METAL MINING



FOR 5TH SEMESTER MINING ENGINEERING STUDENTS



PREPARED BY-

PRABHUTTA MISHRA

(LECTURER IN MINING)

GOVERNMENT POLYTECHNIC JAJPUR.

5th Semester, MINING

UNDERGROUND METAL MINING

Sl.No.	Topic	Periods:	L
1.	Access to ore body		05
2.	Development in underground metal mines		12
3.	Comparative study between Coal & Metal Mining		03
4.	Stoping Method		18
5.	Stone Drifting.		07
6.	Rock burst.		05
7.	Face mechanization		<u>10</u>
			60

RATIONALE

As Mining Engineer, one should have the knowledge in fundamental principles of generation in underground metal mines.

OBJECTIVES

On completion of the subject, students will be able to :

1. Describe various methods to access an ore body.
2. Explain various methods of development used in underground metal mines.
3. Compare between coal & metal mining.
4. Explain various stoping methods used in u/g metal mines.
5. Stone Drifting.
6. Explain causes & prevention of rock burst.
7. Describe about face mechanization.

COURSE CONTENTS (Based on specific objectives)

1.0 Access to ore body

1.1 Classify modes of entries – Adits , inclines and shafts ,applicability of entries.

2.0 Development in underground Metal Mine.

2.1 Explain formation of blocks of mineral deposit.

2.2 Explain level interval

2.3 Describe

- i) Open raising method
- ii) Two compartment method
- iii) Jora raise lift
- iv) Long hole drilling method./Vertical Crater retreat (VCR) method.
- v) Alimak raise climber
- vi) Raise borer.
- vii) Development of Ore pass system.

3.0 Give a comparative study between coal and metal Mining.

4.0 Stoping methods.

4.1 Classify stoping methods with application and factors affecting methods of stoping.

4.2 Preparatory arrangement for stoping.

4.3 Describe the following methods with layout including drilling, blasting, transportation and supports.

- a) Open stoping.
- b) Open stoping with pillar support.
- c) Shrinkage stoping.
- d) Cut & fill stoping.
- e) Square set stoping.
- f) Block caving.
- g) Sub-level caving.
- h) Top slicing.

5.0 Stone Drifting

5.1 Describe conventional methods of drifting. Find out direction gradient of drift. Describe drilling and blasting, support, transportation, drainage, ventilation and lighting arrangements, organization and supervision in mechanised method of drifting.

6.0 Rock Burst

6.1 Explain causes and prevention of rock burst.

7.0 Face mechanization

7.1 Describe use of jumbo drill with air leg.

7.2 Describe various Loading & Transportation System like L.H.D., L.P.D.T.(Low Profile Dump Truck), rocker shovel, spiral chutes and draw points, Scraper etc.

RECOMMENDED BOOKS

1. SME Mining Engineering Hand Book Vol.I & II-1993 edition.
2. Metal Mining – Chacharker
3. Mining Engineering Hand Book – Peele
4. EMT Vol.II – D.J.Desmukh
5. Mining Ground control – Prof. B.S. Verma
6. Rock Mechanics – Jermic
7. Rock Mechanics – Jugger & Cook
8. Metalliferous Mining – Higam
9. Underground Mining Method-Bullock.

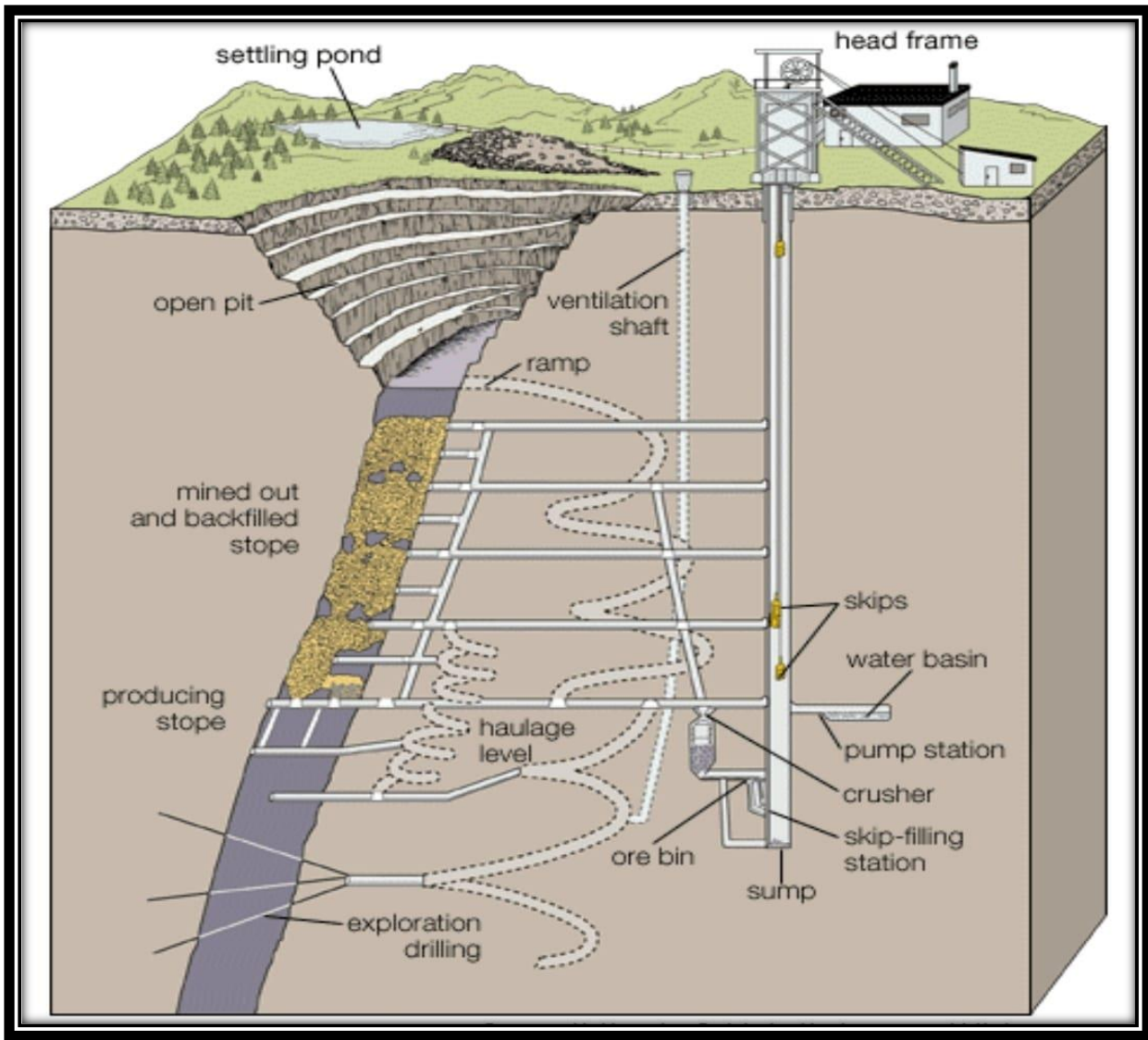

Sectional View of A Typical Underground Metal Mine

When do we mine underground?

- The ore deposit is deep. (*Volume of OB is high*)
- Ore body is steep. (*Vein or Lode deposit*)
- Grade is high enough to exceed costs. (*Economically feasible*)

DEFINATION OF TERMS

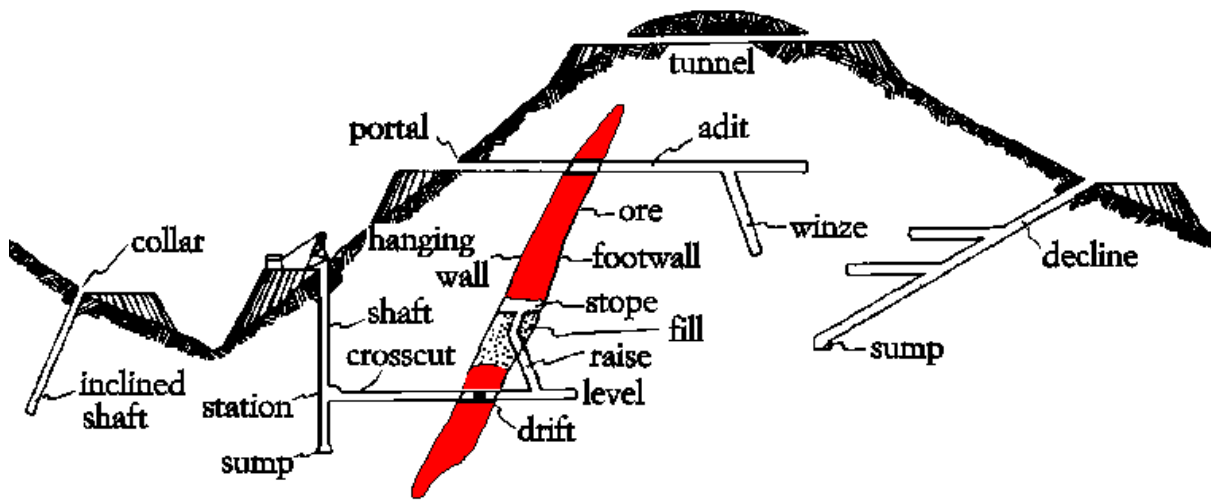

CROSSCUT- A roadway which leads from shaft and passes through country rock to cut across the load or vein at some angle. It is horizontal or nearly horizontal underground opening driven to intersect an ore body.

DRIFT/DRIVE- A horizontal roadway parallel to the strike of the deposit and can be located either hangwall or footwall. It is a horizontal or nearly horizontal underground opening.

CROSS DRIFT/CROSS DRIVE- It is a horizontal underground roadway driven within ore body between the hang wall & footwall and usually right angle to drift or drive.

LEVEL- When the horizontal drivage is driven in the ore body , it is known as level. It is driven with zero or (1 in 200) gradient. It is the secondary mine development operation .

It is always driven always in strike direction for production from the deposit. Two main levels are driven in the ore body. Which is driven in the upper horizon is called *upper main level* & driven at lower horizon is known as *lower main level*.

SUB-LEVEL- System of horizontal underground workings. Normally sub-levels are used only within stoping areas where they are required for ore production. It is a horizontal drivage between two adjacent levels, that connects the two adjacent raises or winzes. This has no direct connection with shaft as in case of main levels.

LEVEL INTERVAL- The vertical distance between two adjacent main levels is termed as level interval.

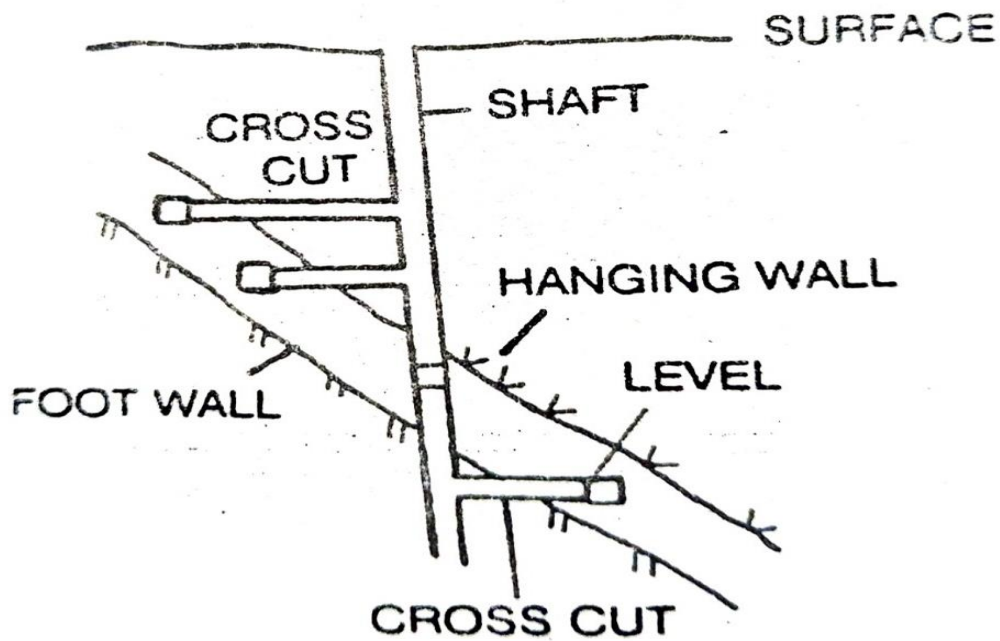

RAISE- A connection between two levels in an ore body driven in an upward direction is called a raise. A raise may be either vertical or inclined. (compare winze)

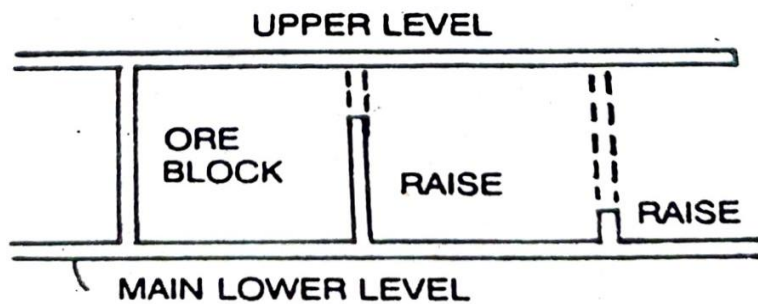

WINZE- A connection between two levels in an ore body driven in downward direction is called a winze. (compare raise).

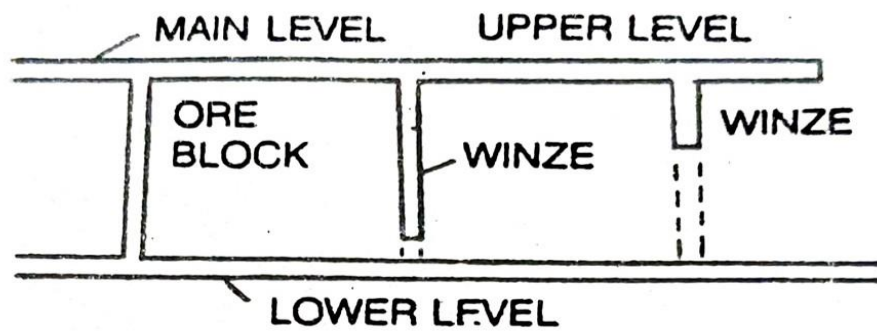

ORE BLOCK- It is a solid ore block, which is bounded between two adjacent levels and two adjacent raises or winzes.

FINGER RAISE- Typically, a system of several raises that branch together to the same delivery point, used for transferring ore.

ORE PASS- An ore pass is a vertical or steeply inclined underground passes for downward movement of ore by gravity. Vertical or inclined opening through which ore is transferred .

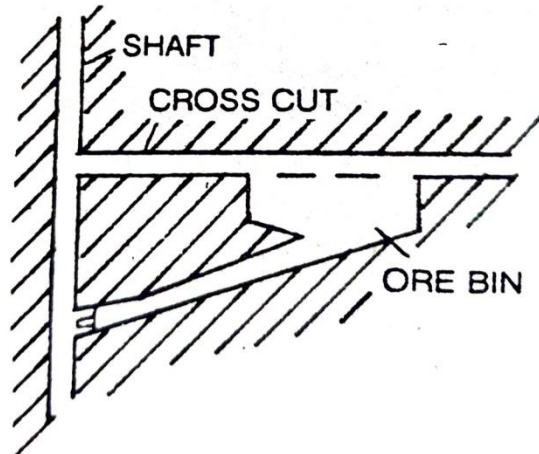

ORE CHUTE- It is an opening or window provided in the ore pass for loading of material or broken ore is known as chute. It is the loading arrangements that utilises gravity.

ORE BIN- It is a storage of broken ore near the shaft. It has the same meaning as Bunker. Its capacity to store 50-300 tonnes broken material.

DRAWPOINT- Place where ore can be loaded and removed. A drawpoint is located beneath the stoping area, and gravity flow transfers the ore to the loading place.

It is a spot on the floor from where gravity fed ore of higher level is loaded into the tubs or mine car.

STOPE- An area where the ore has been extracted and the hangwall is allowed to caved or supported by natural supporting or filling of materials like sand or mill tailings. It is a solid ore block or ore pillar which is under extraction.

STOPING- Stoping is the final extraction of an ore body that has already being developed.

Stoping is the process of extracting the desired ore or other mineral from an underground mine, leaving behind an open space known as a **stope**.

Stoping is the removal of the ore body from the surrounding rock.

For extraction of blocks or pillars of mineral **“stopping”** is the term used in metal mines where as **“de-pillaring”** is the term used in coal mining. (in case of B & P)

BACK- Roof or overhead surface of an underground excavation. When the working place in stope moves in the upward direction such a face is known as back. The working is progressing upward direction in the stope.

CONE- A funnel-shaped excavation located at the top of the raise used to collect rock/ore from the area above.

GRIZZLY- Arrangement that prevents oversized rock from entering an ore transfer system. A grizzly usually consists of a steel grating for coarse screening or scalping.

MANWAY- An underground opening that is intended for personnel access and communication.

RAMP- Inclined underground opening that connects levels or production areas. Ramps are inclined to allow passage of motorised vehicle. Ramps usually are driven downward.

DIP- Angle at which an ore deposit is inclined from the horizontal.

STRIKE- Main horizontal course or direction of a mineral deposit.

WALL ROCK- Wall in which the ore body is enclosed.

UNDERGROUND WORKING- *When the workings of the mine are made below surface, such mine working are known as underground working.*

METALLIFEROUS MINE- *It means every mine other than a coal mine or oil mine.*

FACE – *The moving front of any working place is known as face. It is the inbye end of a drive, level, cross-cut, raise or winze . it is continuously advancing as working is progressing.*

CROWN PILLAR- *When the small thickness of solid ore body is left for the protection of lower level, it is known as crown pillar.*

1.0

Access to ore body

1.1 Classify modes of entries – Adits, inclines and shafts, applicability of entries.

The entries used in mines can be classified into three groups-

1. For opencast mines
 - a. Single entry
 - b. Double entry
 - c. Triple entry system
 - d. Spiral entry system
 - e. Shunt back or switch back entry system
2. For ore body concealed in a hill above ground level
 - a. Adit
 - b. Tunnel
3. For ore body concealed below surface (for underground mines)
 - a. Incline
 - b. Shaft

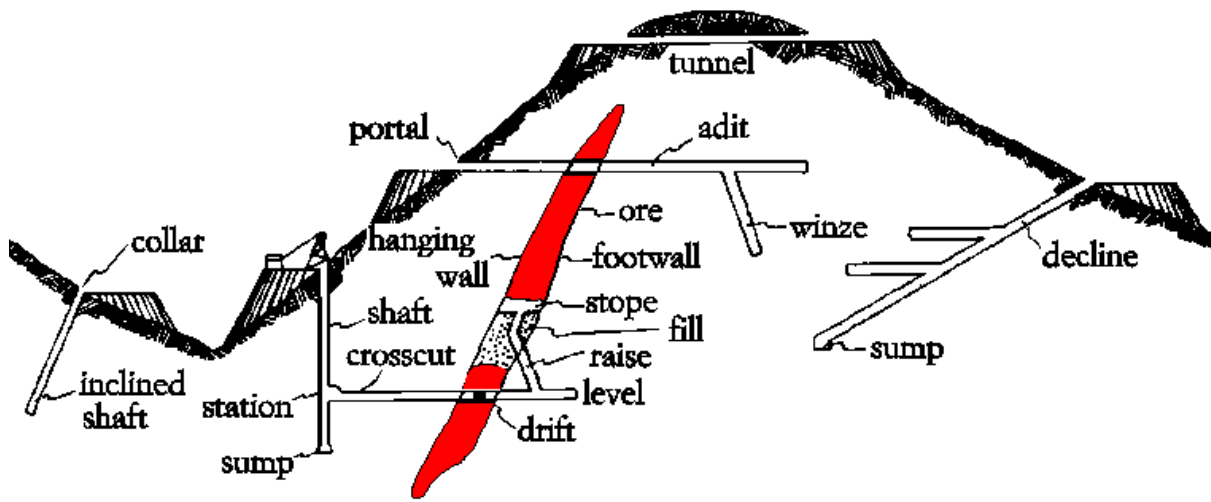

ADIT- The horizontal entry to the ore body whose one end is open to atmosphere is known as adit. Ore body is concealed in the hill and the horizontal road is leading to the ore body. One end of the entry is open to sky. The broken ore is carried out of the mine by this entry. A number of adits can be set at different levels from the surface.

Adit, a horizontal or near-horizontal passage driven from the Earth's surface into the side of a ridge or mountain for the purpose of working, ventilating, or removing water from a mine.



Applicability – The ore body is within the hill and above the surface level.

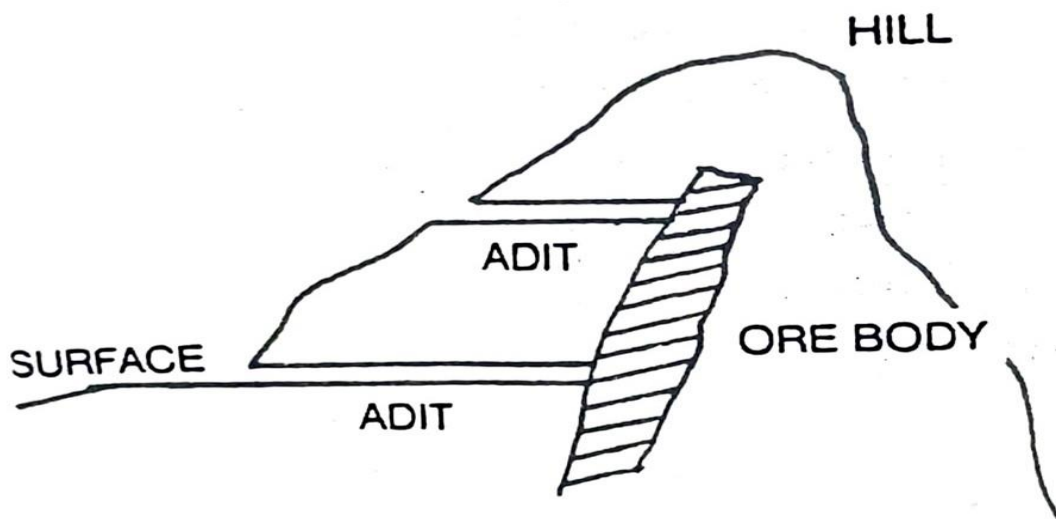

TUNNEL- The horizontal entry in the hill (to the ore body) whose both ends are open to atmosphere is known as tunnel. It has the same meaning in mining as **adit** but its both end are open to sky. The ore body is approached and worked within the hill. The entry to the working & transportation of materials are from either ends.

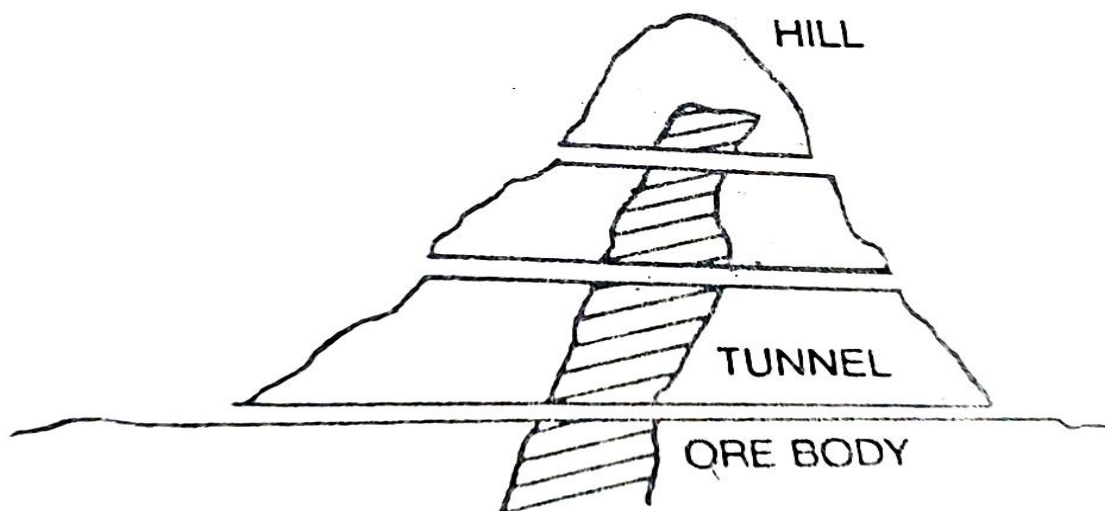

Applicability – The ore body is within the hill and above the surface level.

INCLINES- When the orebody is below the surface level and close to the surface, the ore body is approached by incline roadway which is known as incline. The ore body is worked by the underground mining method from the incline roadway. It is an inclined entry from surface to underground. Its one end on surface is opened to sky. It has slope from horizontal.

The shape of the incline may be rectangular, square or rectangular with circular arc in the top. The width of the incline may be upto [3.5](#) meter and height varies from [1.2 to 2.5](#) meter. The maximum inclination is [1 in 3](#).

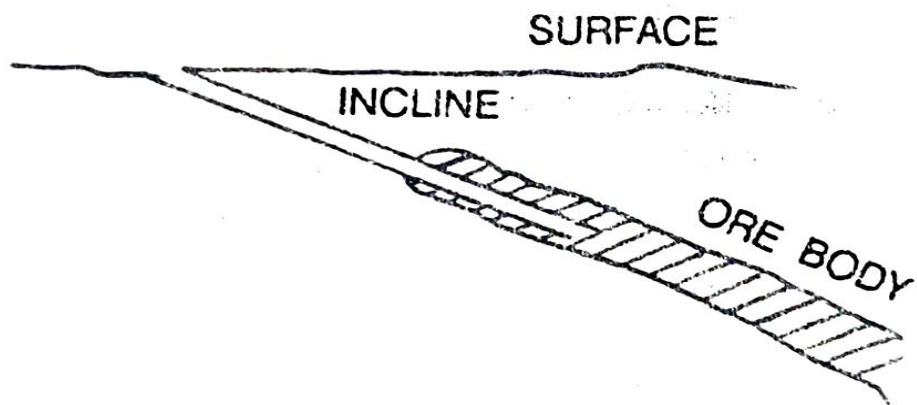

Applicability – The ore body is concealed below the surface.

Advantages-

1. *Simple & direct approach, less costly, less maintenance cost than than shaft.*
2. *Does not require costly head gear structure as required by the shafts.*
3. *Does not require winding engines as required by the shafts.*

Disadvantages-

- 1. Not suitable for ore body at depth.*
- 2. Length of drivage is more than the shaft.*
- 3. The maintenance cost is high , when it is driven through unstable ground & weak strata.*

USES-

Circulation of air, Travelling roadway, to supply material required for working, carrying water pipe line, electric power supply to underground machines, to carrying underground machines, to carry sand stowing pipes.

SHAFT- *It is an entry from the surface to the underground or exit from the underground to the surface. It is used when the ore body is at greater depth from the surface, the underground workings are approached through a shaft only.*

It is a vertical entry, the shape of the shaft may be circular, elliptical, square or rectangular. The circular shaft are more common and its drivage is easy.

Applicability – The ore body is concealed below the surface at depth.



Uses-

The primary purpose of mine shafts is to act as hoisting and travelling-ways; incidentally they serve for ventilation, for pumping and for transmitting power underground by steam, compressed air or other means.

Advantages-

- 1. The centre can be easily transferred to the bottom of the shaft*
- 2. The space of the shaft can be used for laying of power cables, water pipes, stowing pipes etc.*

3. Verticality of the shaft can be maintained.
4. Life of the shaft is more as its wall is exerted by equal pressure from all direction.
5. The drivage of circular shaft is easy.

Disadvantages-

1. Only two cages can be used in circular shaft.
2. The complete space of the shaft is not fully utilised.
3. It is difficult the shape of elliptical shaft during drivage.
4. The repair and maintenance of walling is more.

Give a comparative study between coal and metal Mining.

SL	COAL MINE	METAL MINE
1	Bedded deposit.	Non-bedded deposit.
2	Geological disturbances i.e fold, fault, occurs. Research & planning is very easy .	Geological disturbance not effect.
3	It is softer than metal.	Research & planning less easy.
4	Electricity is the main power.	It is harder than coal.
5	Extraction is easy.	Compressed air is the main power.
6	Roof is soft.	Extraction is difficult.
7	It is uniform in quality thickness & dip.	Roof is hard.
8	Regular in extent shape thickness.	It is non-uniform in quality thickness & dip.
9	They exits in patche or shoots.	Irregular exist shape thickness.
10	It is less varied.	They doesn't exit in.
11	It can be used directly after extraction from the	It is more varied.
12	mines as a fuel. Extraction is not heavy.	It can be used directly processed for getting the mineral & metal.
13	Underground mining is much simpler.	Extraction is heavy.
14	Underground mining produce an infalmbale &	Underground mining is less simpler.
15	explosive gas fire damp must be explosive is done. Sampling are not important day to day operation.	Such danger is not exist in underground metal mines.
16	Geologist is not important in initial exploration.	Sampling are important day to day operation
17	It is not required a high standard of surveying. Gestation/Incubation period for underground is smaller (2-3 years)	Geologist is an essential staff.
18	It is amenable to large scale mechanism.	It is required a high standard of surveying.
19	It is involves detailed exploration & carefully planning before opening up a mine.	Incubation period for underground is longer (4-5 years)
20		It is not amenable to large scale mechanism
21		It is involves more detailed exploration and careful planning before opening up a mine.

5.0 Stopping methods.

Stope : It is a solid ore block or ore pillar which is under extraction is called stope.

Stopping : It is the method of extraction of ore from a block or pillar formed during development. As a rule stopping is started on each side of a raise winze connection.

Stopping Method : Stopping is the final extraction of an ore body that has already been developed. The main work consists of drilling & blasting of ore. Removal of the broken ore from working place & supporting the ground, so that the operation can be carried out safely varies methods of stopping are adopted have been adjective to exploit the ore in the safest & economical way observing the rule of conservation of minerals.

Development in underground Metal Mine

Explain formation of blocks of mineral deposit.

In early stage an underground mine required carefully planned network of shaft drifts and rises etc. The formation of network of shaft drifts and rises is known as development of the mine.

At the time of development following points should be kept in mind.

- 1. The deposit has to be divided in separate blocks by driving drifts, levels, horizon from the shaft.*
- 2. The haulage drive at any horizon from footwall should be straight and wide with much as possible.*
- 3. The mineral are transported downwards in different section to the lower levels as far as possible. All ore carried which is located usually at lower levels.*
- 4. Normal mining or stopping is carried out from boundary to the shaft in a retreating manner.*
- 5. With steep deposit the miners enter the working from above.*
- 6. Timber and other materials tools and machinery are transported to the mine from upper levels to the working place.*
- 7. Filling or packing materials are transported to working place through upper levels and then down to the site by tubs. Now a days filling material are hydraulically transported.*
- 8. The support used in working place should be lasting to avoid the expense stopping.*
- 9. Air current must goes to the lower levels and then rises to upper levels to ventilate the working district.*

Explain level interval.

The vertical distance between two levels is known as level interval. Level driving is narrow work involving more cost per m³ than stoping. Each level requires timbering haulage track, pipe line, loading machine and haulage machine. The cost of the plants crusher and ore chutes can be minimized by connecting haulage on alternate or every 3rd level.

During lateral development in metal mines the level interval varies between 15-100m.

The drive cross cuts drifts, benching of levels gives the correct idea of deposit their quality and quantity.

Level interval are short if,

- *The deposit has not proved adequately during explosion stage.*
 - *The deposit is irregular in dip quality and quantity.*
 - *Some of the ore body has been missed during initial prospecting stage.*
- High grade of ore requires proper levels to be close together to avoid missing ore.*

Thicker the ore body lesser level interval. If ore body is thin level interval is more.

The selection of level interval is governed by least cost per tone of ore, mined by method of mining. The economical level intervals in any mine decided by management taking into consider the factors.

Describe raising methods in metal mines.

i) Open raising method, ii) Two compartment method, iii) Jora raise lift, iv) Long hole drilling method, v) Alimak raise climber, vi) Raise borer

i) Open raising method : *For moderate length upto 8m and inclination of 40°-60° with the horizontal. In order to accommodate the stopper and starting drill steel of 800mm length, a clear hand of 2m is required.*

Description:

- *This is simple and most common method adopted in majority of metal mines.*
- *The workers stand on a platform made of timber supported on iron bars into the footwall.*
- *The drill hole is done by jackhammer and generally done by wedge pattern.*

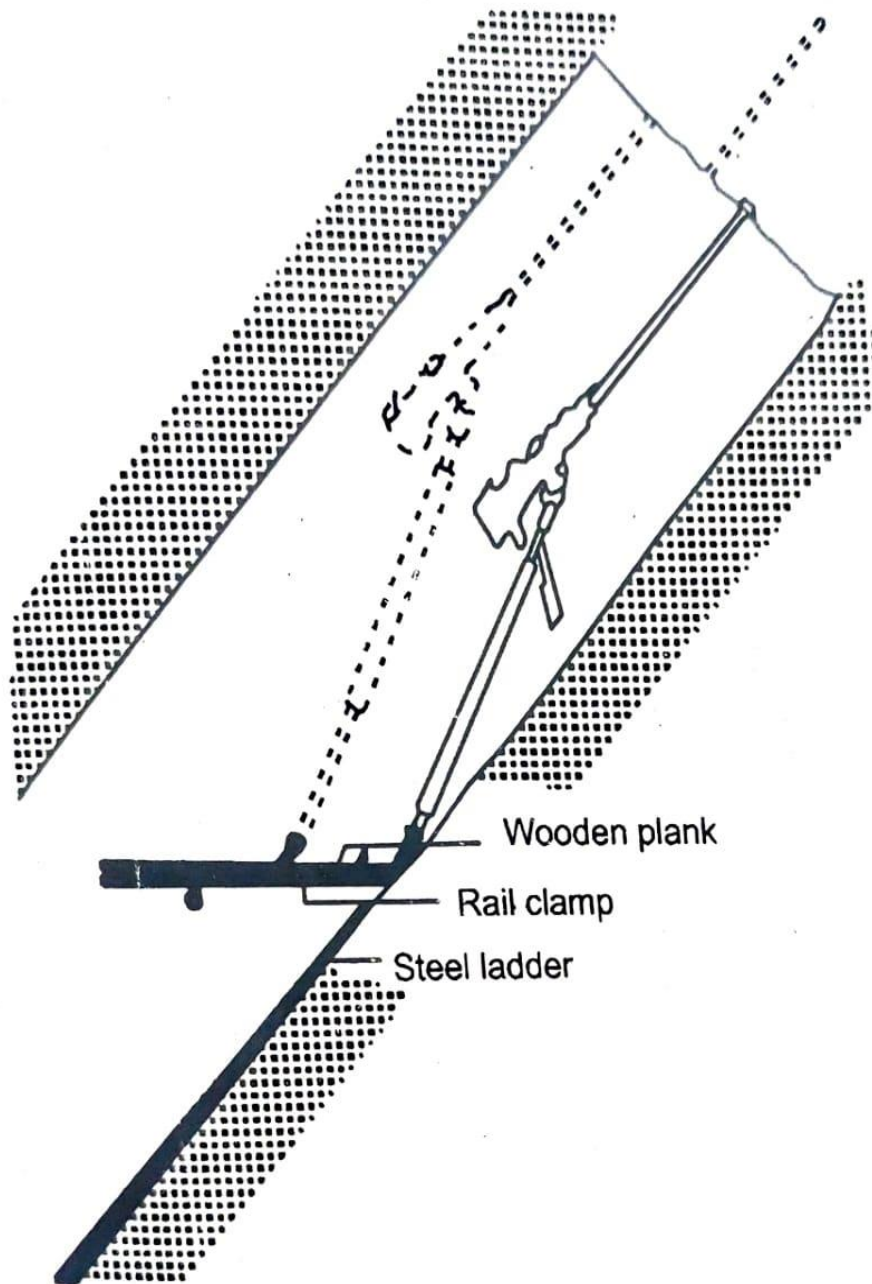

Open raising

- *Holes are 32mm dia and 1.5m deep.*
- *Before each round of blasting the platform is dismantled.*
- *Immediately after blasting compressed air is forced to the working face to remove the fumes of blasting and for ventilation.*
- *The platform is shifted after 2 to 3 round blasting i.e. after getting a sufficient progress.*

Disadvantages :

- Lack of ventilation.
- Damage to pipes and ladders etc, from the blasting.
- Loss of efficiency when the raise go higher as the workers have to frequently ro up and down the ladders.
- Platfrom holes requires careful alignment.

ii) **Two compartment method** : Adopted for vertical or very steep raises. Relatively large cross section. The working stage rests on 2 or 3 stalls temporarily set into holes, made in walls of the raise. If consists of wooden plunks laid over stalls.

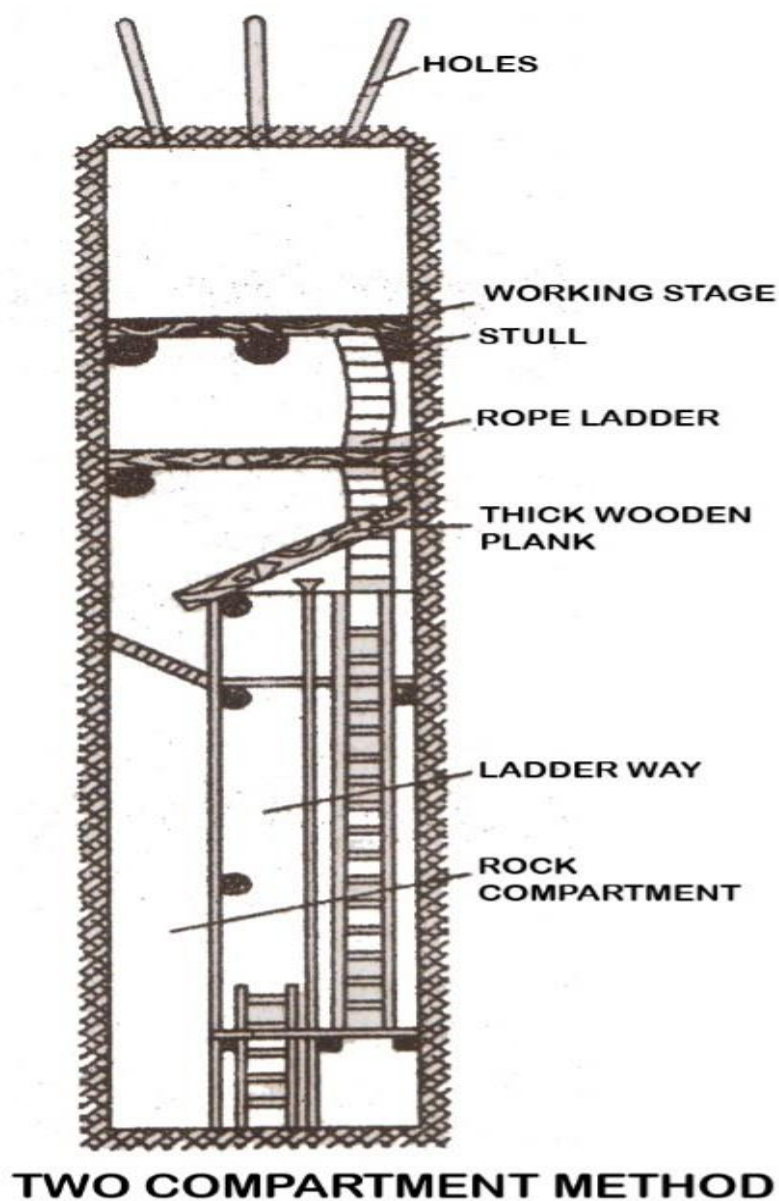

Description:

- *Depending upon requirement two or three compartment are made.*
- *In two compartment method one compartment will be serve as ore pass and the other compartment will serve as man ways, pipes, cables etc.*
- *Initially the excavations 2m done from the lower level.*
- *Then the raise is divided into compartment and the raise is driven continuously.*
- *After getting sufficient progress, the platform is extended. Generally after two or three blasting compartment is required to be extended.*

Advantages :

- *Strong platform can be erected.*
- *Pipes, cables are well exacted.*
- *Since one compartment is act as ore pass, so loading is easier at lower ends.*
- *Person can be protect in the compartment when climbing from flying rock or adjacent roof on side fall.*

Disadvantages :

- *Ventilation is sluggish.*
- *Maximum space occupied by compartment.*

iii) Jora raise lift :*For vertical raise. The strata should be strong.*

Fig - Setup for Raising with the Jora Lift/Hoist

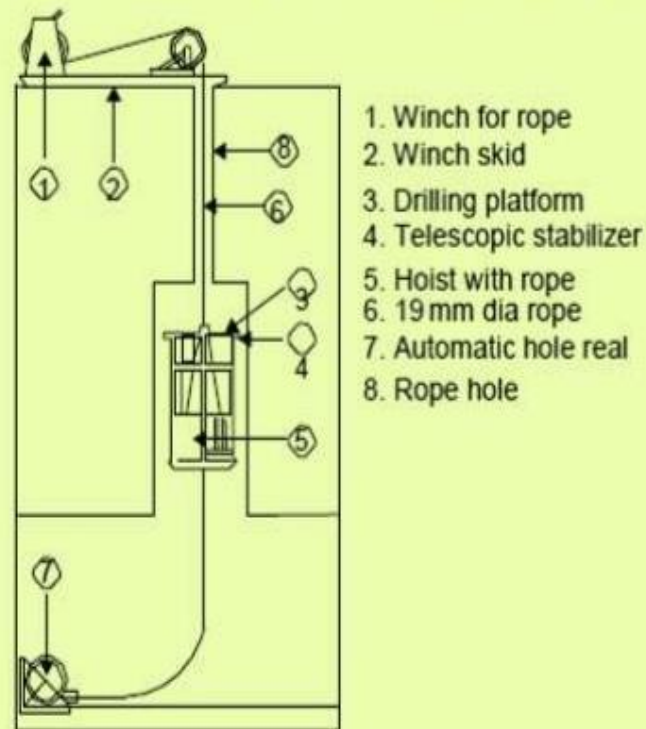

Description:

- In this method a bore hole is drilled upper level to meet lower level.
- The bore is drilled such that it represents the center of raise drive.
- A small hoist pulley is set in the upper levels from roof. The pulley is set such that it is above the bore hole.
- The pulley carries a steel wire rope on end of the rope is wound on hoisting drum set in the upper level. The other end of rope passed through this hole. This end of the rope will be in the lower level.
- Wedge cut holes are drilled in the roof of lower level around the rope. These holes are charged with blasting cable.
- The face is well dressed and blasting material shoveled and dropped in lower level for further transport.
- The raise is ventilated for 10-15 minutes after blasting.
- The complete area of the raise is highered. Now the platform is withdrawn, the jora compartment is made free. The jora raises is further raised. When the canopy is just touching the roof of raise it is stopped.

Advantages :

- It is suitable for vertical and inclined drivage of raise
- Preparation is very quick and less time is lost in setting the platform.
- The ladder way is not required as the workers are traveling in jora compartment.
- The time wasted on softening is less.
- The workers works on a strong protecting cover of canopy, hence there is no danger to workers during drilling.
- Time is not wasted in loading as the blasted material on the platform is shoveled to lower level.
- The working progress is high.

iv) Long hole drilling method :

In this method, the size of the raise is marked on the floor of upper level. The center of the raise in the upper level roof and on floor.

Raising is through long hole, all the drilling loading and blasting operation are performed from horizontal working. There is no need of miner presence at the face.

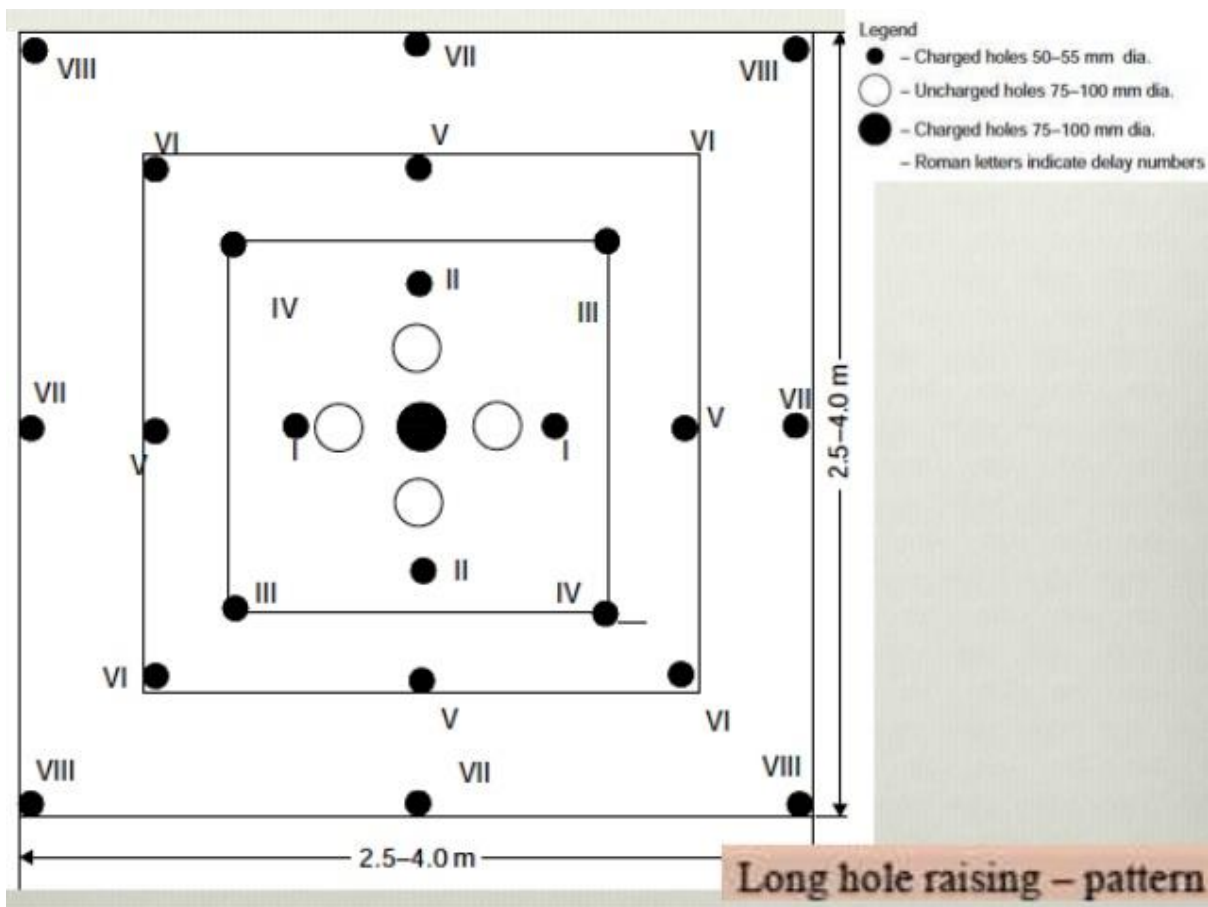

In order to put the raise between horizontal working 1 and 2 long parallel blast holes 3 are drilled from the upper level.

The holes are then fired portion wise, either simultaneously or in succession.

The length of the sections depends on the properties of rock ranging from 1.5-6m or even 9m.

The bottom of the blast hole is filled with plugs 4 from below and explosive charges 5 are lowered down into the holes on string. The holes are then stemmed material 6.

the explosives are fired by detonating fuse. For better accuracy care should be taken that straight without any deviation.

The practical limit in adopting this method is holes of 15-50m at a maximum inclination of 35°.

The method is used only in firm ground mainly for excavating cut out raises in stoping.

v) Alimak raise climber : *The method of driving long raise with the help of machine called. Alimak raise climber was introduced in 1957.*

The Alimak raise climber consists of :-

- 1. A reel with air hose of provide compressed air to the twin air motors causing travel of cage. The reel automatically winds upto the hose when the raise climber descends and feed its during ascent.*
- 2. Guide the rails with the rock and pinion. The length of guide rails 1 or 2m. Some pieces are suitably curved for smooth profile. The guide rails are bolted into rock bolts fitted in side of the raise.*
- 3. The guide rails have recess to carry 2 compressed air tubes. 1 water tube and a telephone cable which is used for blasting.*
- 4. The rock bolts are of expansion shell type recoverable spears are provided to cover up the length between the rock bolt and guide rail.*
- 5. There is a cage that travel along the guide rail and carries the driller and other screw to the face of the raise.*
- 6. The working platform on the top of cage materials are transported on the platform.*



7. *compressed air drive unit with air, motor for travel of the cage.*
8. *Protection canopy.*

The Alimak climber can be used only where the raise is driven at an angle 40° or more with the horizontal since the rock blasted at the face of the raise has to come down by gravity.

Advantages:

1. *The materials falls due to gravity in lower level.*
2. *Loading of material in lower level is quick.*
3. *Much of the time is saved by climber as workers are riding in it.*
4. *No ladder ways, pipes lines etc. are required.*
5. *Dressing is safe under canopy.*
6. *Platform is not damaged.*
7. *Cycle time is short.*
8. *It is quick method.*
9. *Suitable for vertical and inclined raise.*

vi) Raise borer : *Raise bore are first introduced in mines of western countries in 1962 and at present 300 raise bores are in use throughout the worlds.*

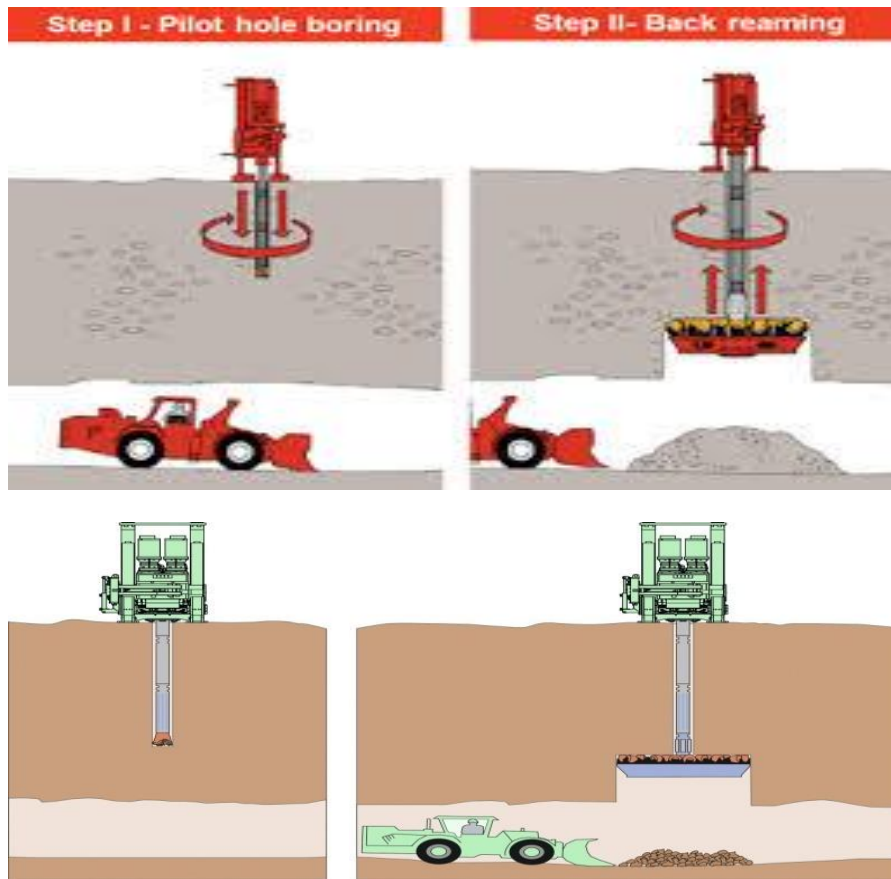

1. *The method of raise drilling of pilot hole, 230 mm to 300 mm dia between two levels at the site, and in the direction of proposed raise and then reaming the pilot hole by reaming bit to the size of the raise.*
2. *If the pilot hole is reamed from upper level to the lower level, it is known as down reaming method. If the pilot hole is reamed from lower level to upper level, called up reaming method. The upreaming method is commonly adopted.*
3. *The cutting rock fall down from the face by gravity and the pilot hole does not need large dia holes. Down reaming method demands pilot hole of large diameter to permit cutting rock between drill rod and the hole sides.*
4. *Normally the diameter of the drilled raise varies from 1 m to 3.7 m as the raise drill bit are available in these sizes.*

Driving rises has often creates difficulty in many mines using conventional method. Ventilation, transport, safety of person, cost are the problem in conventional raise. Now hard rocks can be cut by various type of rotary bit developed in recent years. This is possible by raise bore method ranging from 1 m to 3.7 m dia.

Advantages :

1. *They are usually drilled faster.*
2. *They are less cost in many cases.*

3. *Personnel are not exposed to the hazards of raise driving in drilling, blasting method.*
4. *The finished section is often smooth which offers less resistance to flow ventilation of air and drilled raise may not require support.*
5. *A large cross section are not needed and a small dia raise is easier to drill, if can be drive congenitally.*

The raising cost per length becomes less as the raise length increases.

4.0 Stoping methods.

Stope : *It is a solid are block or ore pillar which is under extraction is called stope.*

Stoping : *It is the method of extraction of ore from a block or pillar formed during development. As a rule stoping is started on each side of a raise winze connection.*

Stoping Method : *Stoping is the final extraction of an ore body that has already been developed. The main work consists of drilling & blasting or ore. Removal of the broken ore from working place & supporting the ground, so that the operation can be carried out safely varies methods of stoping are adopted have been adjective to exploit the ore in the sagest & economical way observing the rule of conservation of minerals.*

Classify stoping methods with application and factors affecting methods of stoping.

Classification :

(A) Stopes naturally supported.

(1) Open stoping.

(a) Open stopes in small ore bodies.

(b) Sublevel stoping.

(c) Long hole stoping.

(2) Open stopes with pillar supports.

(a) Casual pillars.

(b) Room (or stope) and pillar (regular arrangement)

(B) Stopes artificially supported.

(3) Shrinkage stoping.

(a) With pillars.

(b) Without pillars.

(c) With subsequent waste filling.

(4) Cut and fill stoping.

(5) Stulled stopes in narrow veins.

(6) Square-set stoping.

(C) Caved stopes.

(7) Caving (ore broken by induced collapse)

(a) Block caving : including caving to main levels and caving to chutes or braced raises.

(b) Sublevel caving.

(8) top slicing (working under a mat, which together with caved overburden follows the mining downward in successive stages)

(D) Combination of supported and caved stopes, (as shrinkage stoping with pillar caving, cut and fill stoping and top slicing of pillars, etc.)

Application of underground metal mining methods.

Type of ore body	Dip	Strength of ore	Strength of walls	Possible Method of Mining
Thin bodies.	Flat	Strong	Strong	Room and pillar, casual pillar, Open stopes.
		Weak or strong	Weak	Top slicing, Longwall
Thick bodies.	Flat	Strong	Strong	Sub-level stoping, Room and pillar, Cut and fill
		Weak or strong	Weak	Sub-level caving, Top slicing
		Weak	Strong	Square set, Cut and fill, Sub-level stoping.
Narrow veins.	Steep	Weak or strong	Weak or strong	Resuing in (a) Open stopes or, (b) Stulled stopes
Thick veins.	Steep	Strong	Strong	Open stopes, Sub-level stoping, Shrinkage stope, Cut and fill method.
	Steep	Strong	Weak	Cut and fill stopes, Square set stope, Top slicing, Sub-level caving
	Steep	Weak	Strong	Open casual pillar, Square-set stope, Top slicing, Block caving, Sub level caving
	Steep	Weak	Weak	Square-set stopes, Top-slicing, sub-level caving
Massive		Strong	Strong	Shrinkage stope, Sub-level stoping, Cut and fill stope
		Weak	Weak or	Square-set stope,

			strong	Top-slicing, Sub-level caving, Block caving
--	--	--	--------	---

Factor affecting methods of stoping :

Thickness of ore body : There are ore bodies which are thin, thick and extra ore bodies. Thin ore bodies are suitable to work with breast-stoping method.

Dip of the ore body : The ore bodies with low inclination and not extending 35° inclination are suitable for breast stoping method.

Character of ore bodies : Some of the ore bodies are strong and some of the ore bodies are weak.

Character of walls : Some cases the hanging wall or footwall of ore bodies are strong and in some cases either the hanging wall or footwall or both may be weak.

Cost of ore bodies : Some of the ore bodies contain, costly minerals and some of the ore bodies costly due to rich mineralization.

Nature of Mineralization of ore body : The ore body contain low percentage of mineral can be worked by breast stoping method.

Continuity of ore body : Some of the ore bodies are continuous and regular ore bodies are worked by timer stopped method and shrinkage stoping method.

Cost of supports and availability : In case of timber stope method and top slicing method regular supply is supplied.

Depth of the ore body from surface : When ore bodies are at shallow depth the harring bore method can be used.

The shape, size and regularity of the deposit.

Mineralogical character and value of ore and the distribution of values.

The dip, width and strength of the ore.

Nature of overburden.

Surface features : their support vis-à-vis caving.

Possibility of dilution of ore with waste.

(A) Open stoping : It is a stope in which no filling or timber is used to support walls and only simple forms of scattered timber is used as temporary supports. The walls are sometimes supported by temporary or permanent pillars of ore, Open stoping permits of mechanization in drilling, loading and hauling. Dilution of ore is minimum. A typical stop block may have maximum dimensions 30m X 120m with the height varying from 10m to 50m. Steeply dipping ore bodies are also extracted by open stoping but up to a depth of about by intermittent pillars.

Open stopes further classified as follows :

Overhand stoping

Underhand stoping.

Breast stoping.

(a) Overhand stoping : The two levels enclosing an ore block are connected by raises at interval, 25-40m and stoping starts from one direction only. The stoping operation proceeds from lower main level towards the upper main level and ore is extracted in an ascending manner. Horizontal slices are taken parallel with the haulage level. If the ore body has a mild gradient which prevents gravitation of blasted ore, scrapers are used to collect and load it into mine cars. In the method of overhand stoping with stull timbering the preparatory arrangement consists in driving roof haulage drift and raise from lower level to upper level. If the ore body is not steep and nearly 3m in thickness. Overhand stoping is replaced by room and pillar method of stoping. In thick ore body (nearly 3m and above) stoping dipping the overhand method of stoping is usually changed to shrinkage method or sub-level method of stoping.

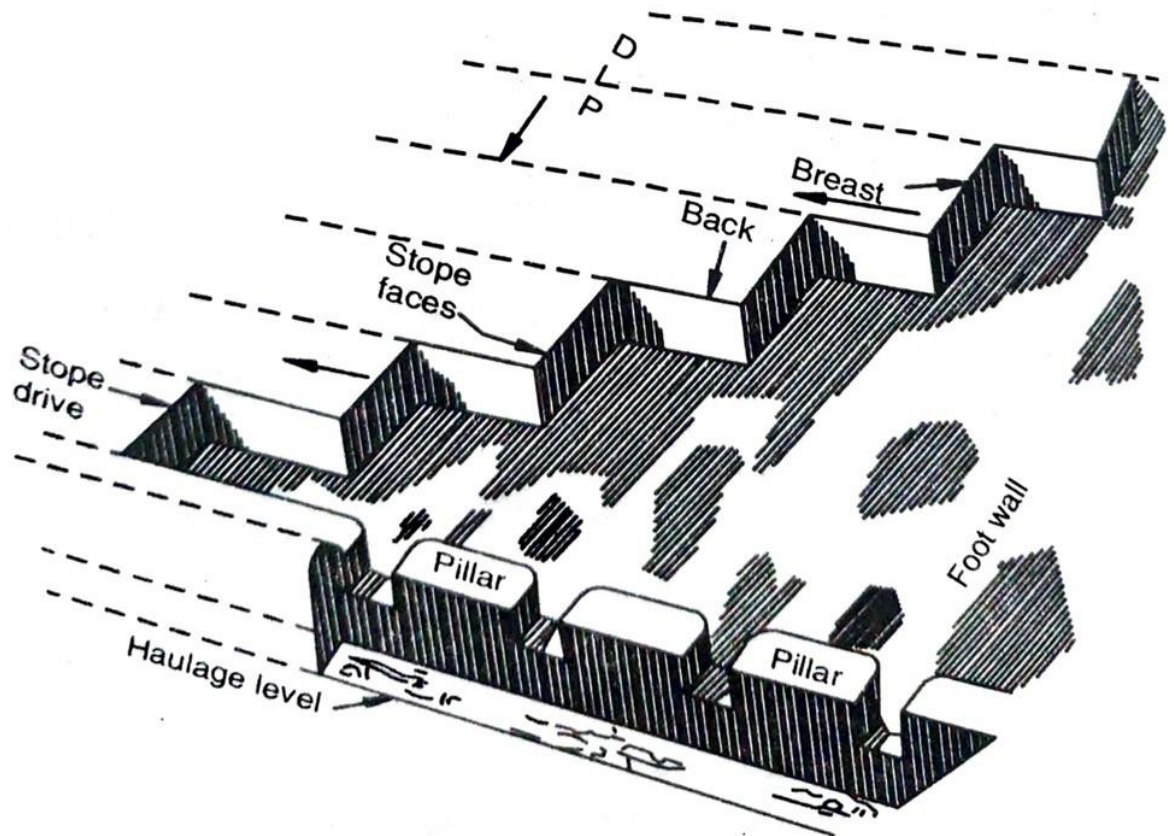

Overhand stoping.

Condition :

The thickness is selected is upto 4.5m.

The ore body required strong.

Both hangwall and footwall should be strong.

The inclination of ore body is 40°-90°.

Preparation :

Preparation are made for ventilation supply of power, supply of material, addition man power and additional handling of production.

The lower level is prepared for ore transport.

Development :

The ore body is approached from the shaft, inclines or adits.

The ore body is further approached by cross-cuts, set regular interval from shaft and inclines.

When cross-cut touch the ore body, the ore body is developed by driving the levels or companion levels at their horizons.

These levels are inter connected at regular intervals, by raise or winzes.

The raise and winzes are connecting the upper and lower level.

When the development of two adjacent levels is complete the stoping operation is under taken.

Advantages :

The full advantages of gravitational force is taken from face.

Blasting efficiency is high.

The broken ore fall away from face.

The danger is less.

Ventilation is good.

The dust and smokes can be easily cleared.

Disadvantages :

Setting of platform can't done easily.

Sometimes drilling creates problems.

No. of benches blasted are 3-4 only.

Muck falls on body of workers.

Not suitable for weak ore body.

Selective mining is not possible.

(b) Under hand stoping : It is used in working thin steeply dipping veins enclosed in strong wall rocks. In an underhand stope the face is below the driller who is supported partly by footwall. The stope is worked in a downward direction from upper main level to the lower main level commencing from a winze. A horizontal slice 2 to 2.5m high is started on top of an ore block. The ore is broken in horizontal slices. Miners stand on the steps formed and drill the shot holes downwards. It is a common practice to open new chutes as the stope is extended along the strike. Underground

stopping is practiced relatively rarely. The transport of ore is somewhat difficult and blasting efficiency is poor as the blast has to lift the ore that is blasted. Ventilation is also not simple. Efficiency of miners in breaking the ore is however high.

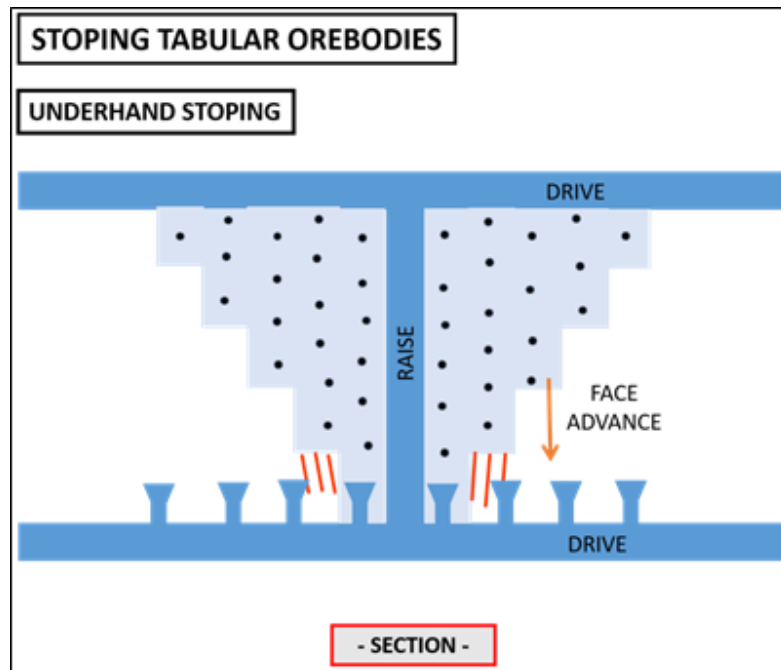

Advantages :

- It allows high blocks.*
- It makes a systematic sorting of the ore possible.*
- Broken ore falls clear of the face.*
- High wall & face can be conveniently examined.*

Disadvantages :

- The performance of the drillers is less.*
- With a dip exceeding 45° platform have to be erected in the stopes for the mines.*
- Much supporting material is used.*
- The losses of fine ore are considerable.*

(c) Breast Stopping : Breast stopping is suitable for

- (i) The deposit must be horizontal or mild up.*
- (ii) Laying at a moderate depth.*
- (iii) Country rock must be rock.*
- (iv) Medium thickness of ore body upto 5 m.*

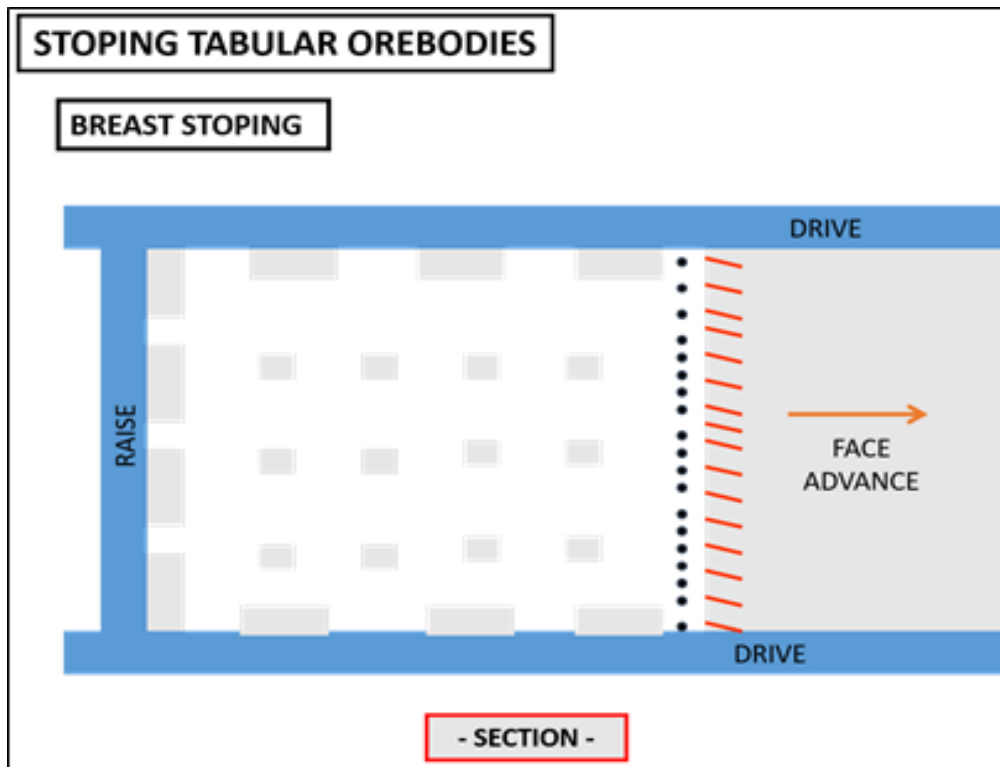

Description :

The horizontal movement of a vertical face is called breast or when the holes are drilled in front of face such holes are called breast holes. When a stope is extracted by breast holes the method of stoping is called breast stoping.

In this method 2 levels are driven in the horizontal direction & serve for haulage way. In this method ore is broken by flat or slightly inclined holes drilled in a vertical or nearly vertical face (breast) of considerable lateral area, which is being advanced in a nearly horizontal direction and the work resembles that of advancing the face of a very wide drift.

The face is in dip rise direction & mining process along the strike. Breast is used exclusively in the case of open stopes as opposed to the overhand & underhand stope which is adopted with other support systems as well.

Breast stoping is a low cost, simple method much preferred for low grade ore deposits where supporting ore pillars may be left. The ore and the wall rocks should therefore be strong.

The method is best suited deposits of horizontal or mild dip of thickness of upto 5m, lying a moderate depth.

Advantages :

Selective mining is possible.

High intensity is possible.

*Simplicity and low prime cost of ore.
Possibility of mechanization of drilling & load at the face.
More safe than other methods.
No lateral development proceeds mining.
It is simplest method.
It gives high intensity of stoping & competent stoping area.
Higher productivity of mines compares to other method.*

Disadvantages :

*Chances of high ore losses due to in sit pillars.
High stability are required.
Higher output is not possible.
Initial cost is high.
The need for keeping a constant watch of the condition of the back.*

(B) Open stoping with pillar support :

It is two types (a) open stoping with casual pillars and (b) room and pillar method of mining.

Open stoping with casual pillar : *It is more convenient to drill and blast everything in the stope to keep mining costs to a reasonably minimum level.*

Room and pillar method of mining : *It is a standard method of development in coal mines in India, where the development is followed by depillaring for maximum extraction of coal from the standing pillars, supporting the roof over the coal seam.*

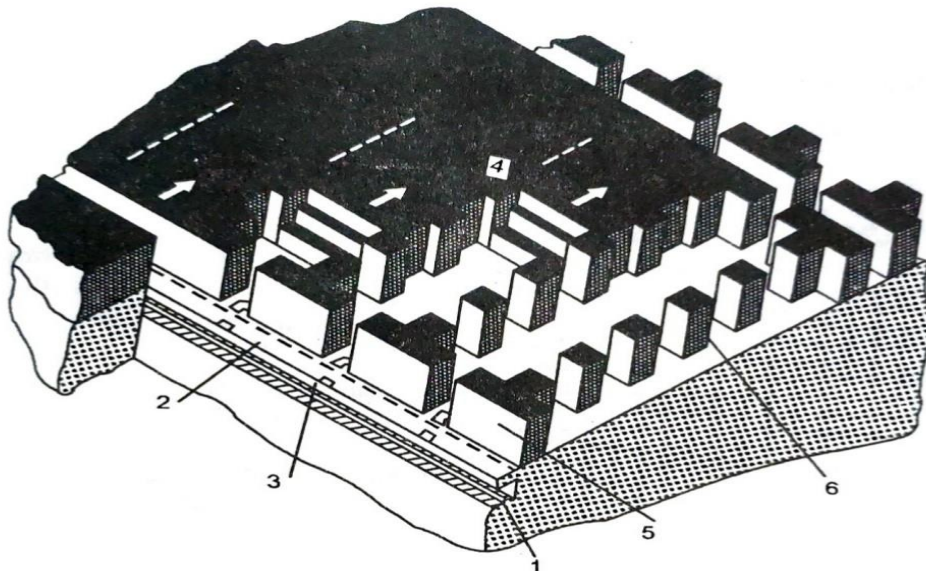

Room and Pillar mining; 1. haulage level in foot wall, 2. drift in ore, 3. ore chute, 4. advance undercut stope, 5. panel barrier pillar, 6. ore rib pillar.

Condition :

when ore body is strong.

Hanging wall and footwall are strong.

the ore body thickness is not more than 4-5 mt.

Inclination of ore body is 0° - 30°.

It is poor mineralization of ore body and less costly mineral.

Description :

In this method the ore is extracted in wide rooms separated by pillars provided in regular manner for support of hanging wall.

The dimension of room and pillars depends on such factors like stability of hanging wall and ore thickness of deposits and rock pressure.

Pillars are generally arranged in regular pattern.

The ore left in the pillars may to some extent be recovered but generally to be required as lost.

Application :

Ores with horizontal or flat dip.

Comparatively stable hanging wall and ore.

Ore body upto 12 m thickness.

Preparation :

The ore block near the boundary is to be stopped first and the stoping operation will be carried up to the shaft.

The last ore block is divided in two valves by driving the raise or winze.

The lower level is provided with main haulage and center raise of the block provided with trackline of the block.

Development :

Ore body is approached through shaft and cross-cut.

The cross-cuts are located at regular interval of 100mt – 200mt.

When cross-cut touch the ore body the ore body is developed by levels.

Here the size of the cross cut is 3-5m wide and 2-3mt height.

As levels are developed at their horizons, they are interconnected by raises or winzes at regular intervals of again 100-200m.

Advantages :

- *The pressure on hanging wall is distributed on barrier.*
- *It is used for comparatively more depth.*
- *The supervision of work is more effective.*
- *work distribution is more.*

- More workers can be employed.
- working can be well ventilated.

Disadvantages :

the loss of ore in barrier pillar more.

The percentage of extraction is less.

(C) Shrinkage stoping :

It is a temporary accumulation of the broken ore in the stope, working in which the broken ore is stored are called shrinkage stopes. In shrinkage stoping the ore is excavated in horizontal slices, starting from the lower part of a slope and advancing upwards i.e towards the rise.

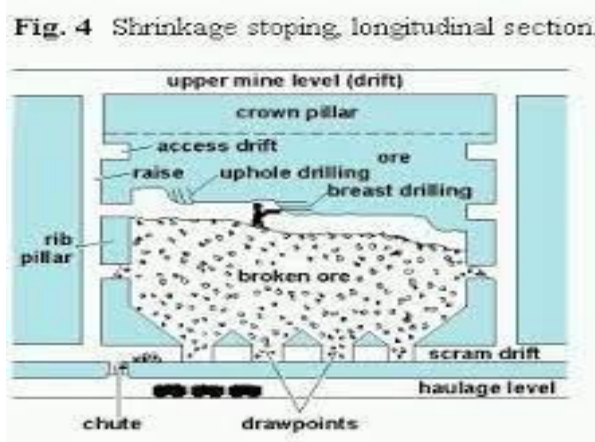

Condition :

This method is used for thick or thin ore bodies.

It is suitable for strong ore body that can stand the pressure in its own weight.

The grade of the ore body required is high as there is the possibility of dilution of ore body.

The inclination required is more than 40° upto 85°.

The dip must exceed the angle of repose of the broken ore,

The ore should be free flowing.

Undercut the stope by taking a complete bottom, bottom slices 5-10 above haulage drift.

Description : In shrinkage stoping the ore is excavated in horizontal slices, starting from the lower part of a stope and advancing towards rise. A characteristics feature of shrinkage stoping is that a part of the blasted ore is left in the stope where it serves both as a working platform for drilling and as support for the stope wall. The ore so left in the stope is removed when the block is fully stoped out.

Shrinkage stoping is based on the fact that when a solid rock is broken by blasting the broken rock fragments occupy a larger volume. The increase in volume may vary from 30% to 70 %.

Application : *Shrinkage stoping can be used in over bodies with :--*

Steep dip : The dip must exceed the angle of repose of the broken ore.

Firm ore : The ore should be free flowing. Too much lime or clayey materials will hamper free flowing. It should not develop spontaneous heating and should not deteriorate during storage in the stope. This problem is experienced with sulphide ores which have a tendency to oxidize and decompose when exposed to air. In most cases these problems can be minimized by limiting the size of stopes, by minimizing the duration of mining activity in each stope.

Thickness of ore body from 3m to 12m.

Comparatively stable hanging and footwall. It can not be used in weak rock because the sides of the stope would squeeze together. It can be adopted if the wall rocks are slightly weaker.

Preparation : *Preparation for shrinkage stoping consist of :*

Haulage drift along the bottom of the stope.

Cross cuts into the ore under the stope.

Finger raises and cones from cross cuts to the under cut.

Under cut of the stope by taking a complete bottom slice 5-10m above the haulage drift.

A raise from the under cut to upper level for ventilation and manway.

Development :

The shrinkage is an conventional overhand stoping method.

The broken ore is used as support to walls.

In this method, there is complete extraction of narrow vein.

the ore body is approached through shaft or incline.

At regular interval of 50-100 mt the crosscut are developed to reach the ore body.

When two adjacent levels are developed upto the boundary, the complete mine developed the stoping operation is under taken.

Advantages :

- *It is not a cyclic operation as compared to the cut and fill method of stoping.*
- *It is more efficient and cheaper.*
- *The broken ore in the stope forms a reserve to cope with sudden demand for more ore.*
- *No scraping of ore is required.*

- *It involves smaller capital outlay and less development work.*
- *No ore has to be handed in the stope and use of wheel barrows and tubs is dispensed with.*
- *The broken ore with in the compartment form a platform for the workers to work face.*
- *Broken ore is used as temporary support hanging wall and foot wall.*
- *There are less preparation of stope.*
- *No shoveling of broken ore.*
- *Less timber support.*
- *Face ventilation is good.*
- *No loss of firm ore.*
- *Broken ore is clear at face.*
- *Face can be well dressed.*
- *Blasting efficiency is high.*
- *It is a cheap method of working.*
- *Working is safe.*
- *Production can be boosted in short notice.*
- *Faces can be additionally supported.*

Disadvantages :

- *If walls are flexible there is possibility of dilution of ore due to mixing of rock.*
- *Chutes are to be closely placed.*
- *Sorting of ore in the stope is not possible.*
- *Selective mining is not possible.*
- *Large amount of broken ore is locked in stope.*
- *There is possibility of accident or fire.*
- *The chutes may jammed.*
- *Traveling in broken ore is difficult.*
- *There is danger of failure of crown pillars.*
- *The upper level may be badly affected when broken ore is loaded.*
- *The cavity of walls can't be controlled when the broken ore is loaded.*
- *Shorting is not risible.*
- *Mechanization is not possible.*
- *Man power requirement is high.*

(D) Cut & fill stoping :

In cut & fill mining the ore is excavated by drilling and blasting in horizontal slices, starting from the bottom of a stope and advancing upwards.

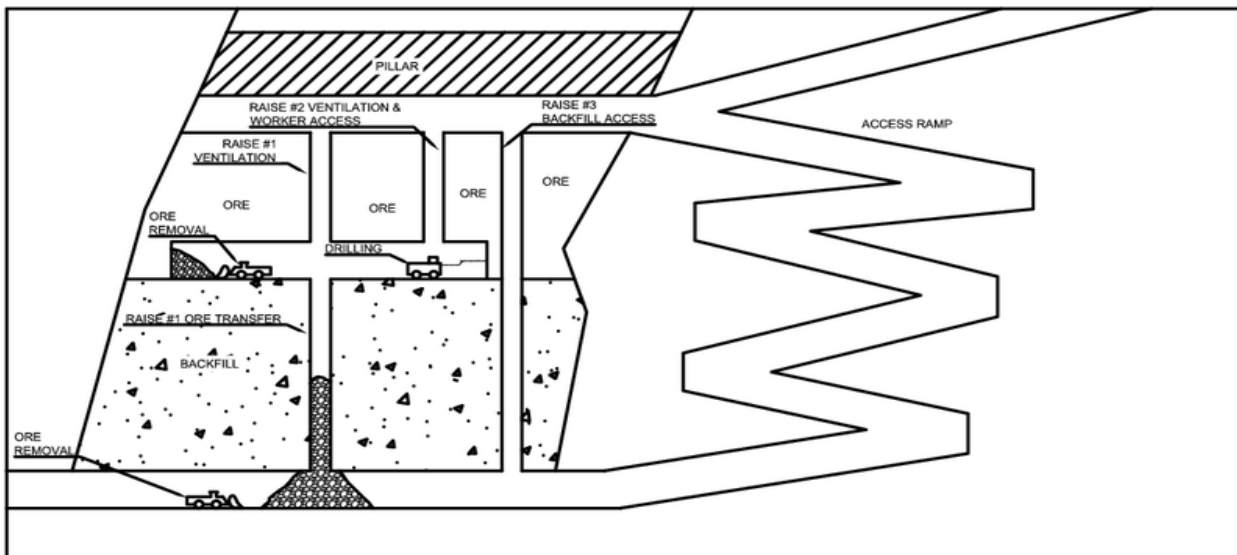

Description :

A slice has a thickness more than 3m. The broken ore is loaded and completely removed from the stope, when one slice of ore has been excavated, the corresponding volume is filled with waste material. The filling serves both as support for the walls and as a floor when the next slice above is mined.

The filling material may be waste rock excavated during development crushed and distributed mechanically over the stope area. In modern cut and fill mining the hydraulic filling method is normal practice. The filling material may be sand, crushed rock, boiler plant ash or slag at smelter plants. The filling material mixed with water, is transported into mine and distributed through pipe lines.

Application :

It can be used with steeply dipping as well as mildly dipping ore bodies with reasonably firm ore.

Smelt as well as large deposits with regular outline can be worked easily.

Important advantage of this method is the flexibility and high degree of extraction.

High grade of ore can be extracted leaving the low grade ore behind in the fill.

Dilution of ore is very little. Therefore it is often used for ores with irregular boundaries.

This method is suitable where ground surface is to be prevented from substances.

Compared cut and fill method offers advantages of selectivity.

Preparation :

Haulage drift along ore body at the lower main level.

Undercut of the stope, usually 5-10m above the haulage drift,

Short raises for manways and ore passes from haulage drift to undercut.

Raises from undercut to the above for transport of filling material and for ventilation.

Provision of sufficient water and filling material and arrangement for their storage and transport.

Adequate pumping capacity for underground to pump out water overflowing from the filled stope.

Development :

The ore slices can be drilled in two different ways, with horizontal shot holes or with upward, vertical holes, for drilling light rocks simple wagons are often used. An advantage of up hole drilling method is that large section of the roof can be drilled without interruption and large round can be blasted.

A the stope proceeds upwards timbering and filling proceeds on a cyclic basis. Cut & fill mining permit of mechanization of drilling and loading operation. Cut & fill mining has a very broad range of application due to the flexibility good recovery and the possibility of mining rather weak rock condition.

Advantages :

- Ore is removed immediately after blasting.*
- There are no fire hazards and no oxidation problem.*
- Preparatory arrangements or stoping are not heavy.*
- A large area is not exposed and the workers work in newly exposed area.*
- Stopes can be brought into production comparatively quickly.*
- Ventilation is comfortable because of small area of stope for air current.*
- Dilution of ore is reduced to the minimum as there is no falling of wall rock.*
- Secondary blasting can be done in stope.*
- The methods provides permanent supports for structures.*
- mill tailings, if they are used for filling, reduce their disposal problem on the surface.*

Disadvantages :

- It is a cyclic method.*
- Production of ore is intermittent unless a few stopes are worked simultaneously.*
- Suitable filling material may not be available.*
- Arrangements for procuring filling material and transport to the stope involves a sizable cut.*

(E) Square set stoping :

It is the method of mining in which the walls and back of the stope are supported by regular frame work of timber called square sets.

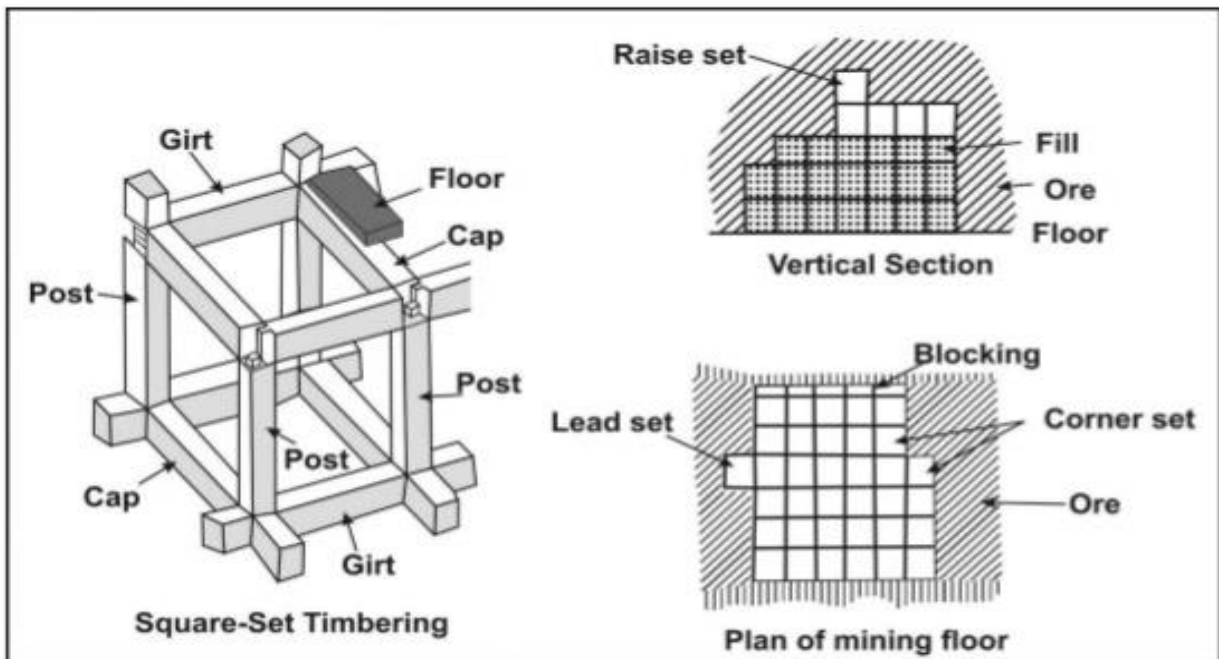

Condition :

This method is suitable for thick and extra thick ore bodies.

The suitable indination in between 40° - 85°.

The ore body is strong and can stand it's own weight.

The hanging wall and footwall are weak and they require support.

The ore body should be costly mineral.

Rich ore body with high percentage of mineralization is preferred.

The deposit required is regular.

There should be continuous supply of timber.

Application :

where the walls of the ore body and back of the stope are weak and don't stand without support even for a weak.

For recovery of fractured remnants and pillars.

Can be used in almost any size of deposit regardless of its shape or depth the method of mining as aquare set stoping is costly and labour intensive method.

Preparation :

the lower levels is used as main haulage level.

The arrangements of ventilation, power supply increased transport of ore and additional manpower is made.

Description :

The square set stope is timbered stope. In square set stoping is support to the walls and back.

The four vertical timbers of a square set are called posts. To start timbering a stope with square sets, sills are laid in trenches cut in the floor of the stope. A clear height of 2m is about the minimum height desirable and at a number of mines posts are 2-3m high in the clear, particularly on main levels or sill floor.

If waste rock filling is used to fill up the square set, such filling provides additional support and the method is then called filled square set stoping.

The square set stoping is labour intensive, costly and requires skilled labour for setting the timber in a systematic manner. The scarcity of timber and gradual depletion of skilled labour makes the system unpopular. It is used in Beloghat mines of MOIL in MP.

Advantages :

- *Irregular ore bodies of any shape can be worked by this method.*
- *It can be adopted where ground condition is bad.*
- *Wasted rock can be stored out and allowed to remain in the stope.*
- *The grade of the ore can be controlled at as each new face, can be sampled.*
- *If the sets are filled with waste rocks as soon as possible after they are erected, only a small space is open at a time.*

Disadvantages :

- *A large quantity of timber is required. It constitutes a fire hazard.*
- *Production of the ore is slow and the OMS is poor.*
- *It is a labour intensive method with high cost of mining.*
- *Square set stoping has a high accident rate compared to other method of stoping.*

(F) Block Caving :

In block caving method, the ore will cave over a small unsupported area. In block caving the ore is divided in large blocks with a horizontal cross section usually larger than 1000m². At the bottom a horizontal slot is blasted, which removes support of the over lying ore.

The under cutting create a series of fractures in the ore body which gradually affects the whole block. The ore at the lower part of the block is crushed by the cracked upper portion and gives. The drilling blasting required only in the lower portion of ore body. The upper portion caves down.

Application :

Block caving is used in large ore bodies.

The ore body should have steep dip.

Ore should be weak enough to cave under its own weight wall rocks also should be weak enough to cave under the weight of the over burden.

Ore should be comparatively low value or grade.

A fairly uniform distribution of values in the ore is necessary.

The surface should be allowed to subside.

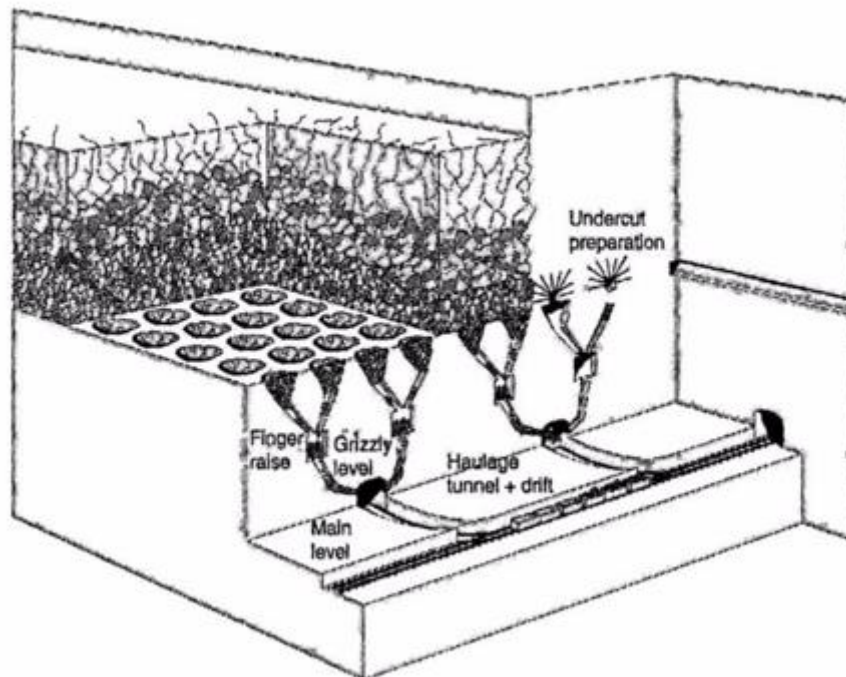

Preparation : Preparation for block caving consists namely of :

Loading or haulage drifts in regular pattern below the bottom of those block.

Ore pass or finger raises upto a grizzly level from such loading or haulage drifts.

A grizzly level for the control of the ore and secondary blasting.

Finger raises and come up to the undercut.

Under cut due to complicated preparation and narrow sections mechanized methods are often difficult to apply.

Advantages :

- *Mining cost is low and may be nearly as economical as in opencast method of mining.*
- *The accident rate is fairly low.*
- *After the caving starts a high rate of production is possible.*
- *Control of ventilation is less compare compared to other methods of mining.*

Disadvantages :

- *Capital expense is large.*
- *Preparation for the stope is complicated and time consuming.*

- *The ore is diluted with waste and there is some loss of ore.*
- *Caving of a block is difficult to control.*
- *There is no chance of selective mining of high and low grade ore.*
- *There is excessive dilution if caving is uncontrolled.*
- *There must be careful supervision of ore drawing.*
- *Mechanization is possible only to a limited extent.*
- *Secondary blasting is required on a large scale.*
- *As in all methods of caving, a large flow of surface water or ground water finds.*
- *At present block caving is not adopted at any of the mines in India.*

(G) Sublevel caving :

Sublevel caving is a development of top slicing method. Sublevel caving is a caving methods where the over burden and part of the ore is induced to cave in. The over burden and the ore must be weak enough to cave readily. Sublevel caving is carried out with timber mat as in top slicing but in recent years the timber wire is replaced by wire netting.

In sublevel caving the ore is divided by sublevels with 8-10m vertical spacing. The sub-levels are developed with a regular network of drifts, covering the whole area of the ore. Each sub-level consists of 2 or 3 slices and the ore at each sublevel is brought down by drilling blasting and loading operations.

When developing the sublevel with a regular network of drifts, in wide footwall drift. But in narrow deposit the drifts are made along the strike.

From the drifts the ore is drilled with a fan shaped pattern in an upward direction. Blasting of fans starts at the hanging walls or at the ends of the ore and proceeds towards the footwall of the ore pass, several drifts and levels are worked simultaneously to keep a roughly even in retreating front.

When a fan blasted the ore caves into the drift, where it is loaded and transported to ore passes. The hanging wall caves continuously and follows the extraction of ore.

Application :

Sublevel caving is used in steeply dipping ore and in other deposits with comparatively large vertical thickness.

The method can be vertical thickness.

The hanging can be used in weak ore.

The surface conditions must slow subsidence.

Due to the dilution and loss of ore sub level caving is mostly used for ores which are not too valuable or which can be connected by a relatively cheap ore dressing process.

Preparation :

The main part of preparation consists of very comprehensive drifting on the sub levels.

In addition to drifts ore passes and raises are required to connect the sub levels with main levels.

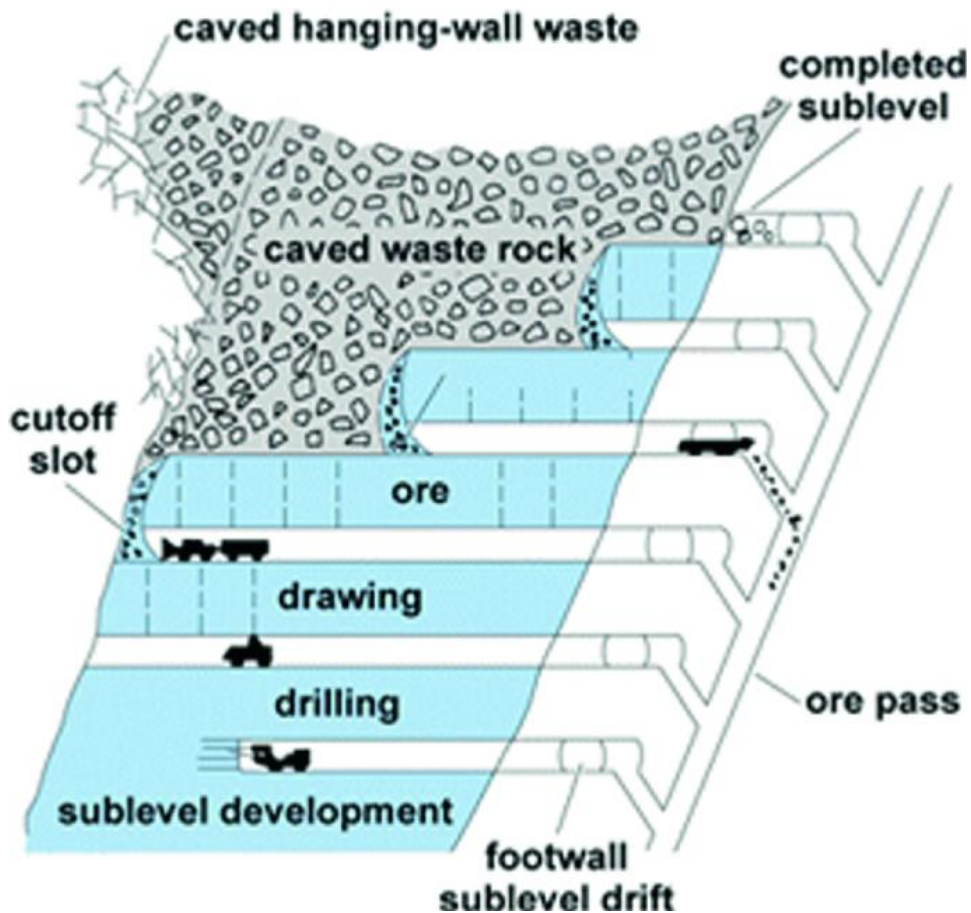

Initially 20% inclined service ramp is driven in the footwall rock.

The ramp normally turns at 180° about every 150m to keep it reasonably close to the rock.

Sublevel are established by driving horizontal access drifts on the ramp approximately every 9m vertical.

In general, drifts in rock are 4.3 m wide by 3.9 m high, while in ore they are 1.9m wide by 3.9m high a wider drifts improves recovery.

Advantages :

- It can be applied to both hard and moderately weak ground.
- It is flexible so that it can be applied to irregular ore bodies.
- All operation takes place in drift size heading, that can be well supported.
- It provide good condition for accident prevention.
- It is suitable for high degree of mechanization.

Disadvantages :

- More dilution of the ore.
- There is practically no sorting of ore in the stopes.
- The stopes are difficult to ventilate.
- Low grade of ore in the over burden or near the boundary of the deposits is lost.
- High development cost.

(H) Top Slicing :

In this method the ore is mined out in a series of horizontal slices by drilling and blasting beginning at the top of the ore body. The ore from first slice is being taken out. Top slice continues a timbered mat is spread out on the floor of the first slice. The timber mat consists of their wooden lags (about 125 mm dia) and thick wooden planks. The next slice of the ore body is then extracted by drilling and blasting. The slices, each about 2-3 m thick are then extracted in a descending manner.

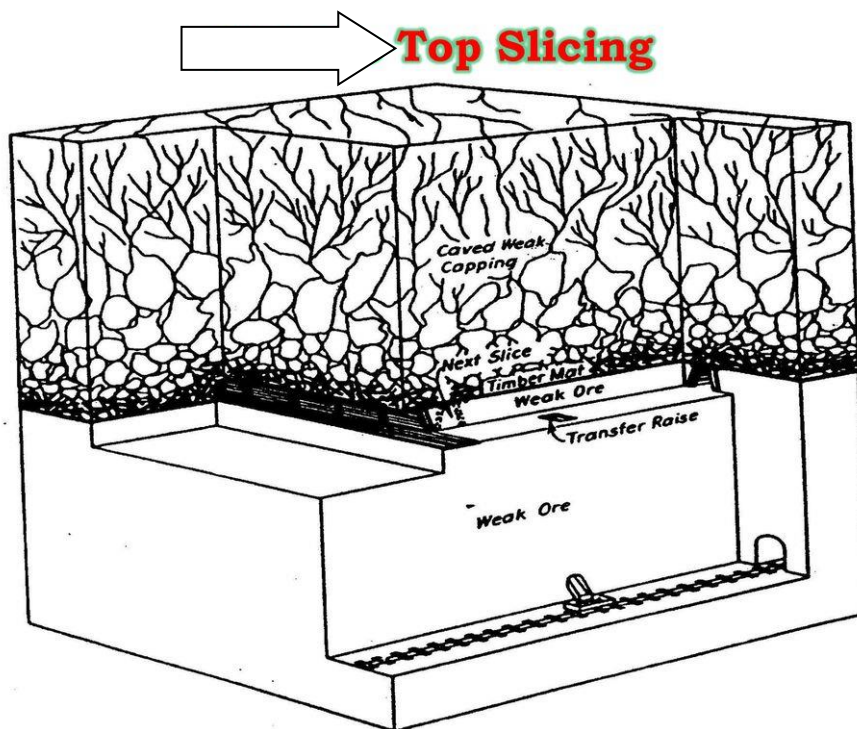

Application : The method is applicable to

Thick deposit of horizontal extent. The minimum thickness of ore body should be 2-3m.

soft ore which is weak enough to stand without support only for a short period.

Weak walls and over burden which can easily cave in.

Ground surface which is not to be supported.

Areas with cheap and plentiful supply of timber as well as skilled timber man.

The timber should be tough and strong.

The stopes or slices may be blasted down so that the ore body remains in good conditions.

Top slicing can be employed under sand and other loose surface material and does not require as clean a mat as does sublevel caving.

Preparation :

The development for top slicing consists of driving a series of drifts and cross cuts at some distance below the top level and then raising to the top of the ore for mining. The ore is removed in slices 2-3 m thick. A block is divided into horizontal slices. A drift is driven under the over burden near and parallel to footwall. The drift extends to each end of the block from the body of the drift cross cuts are driven to the hanging wall. The drift is timbered upon removing the ore from the slice.

Advantages :

- *it is safe method to use where overhand stoping cannot be employed.*
- *It is suitable for intermittent operations.*
- *The method permits of high recovery and dilution is little.*
- *It can be employed under sand or other loose material and does not require as clean a mat.*
- *After the initial development is completed the method can be reasonably cheap.*

Disadvantages :

- *The method causes surface substance*
- *Ventilation is somewhat difficult.*
- *A considerable number of working places are needed for a large output and the rate is not flexible.*
- *Period of development prior to production is fairly long.*
- *Handling of timber and laying of mats is expensive in labour and time consuming as in the case of square set mining.*
- *Waste or low grade ore can not be easily left in place.*
- *The method is not adopted to sorting of waste in the stopes.*
- *Rate of output can not be suddenly increased to meet market demands.*
- *If the roof does not collapse over a long period, its sudden collapse results in air blast and can be dangerous in the slice below.*
- *Top slicing is not adopted at any of the mines in India.*

5.0 Stone Drifting

Drift mining:

- *Drift mining is a process of accessing precious geological material like coal by cutting into the side of the earth.*
- *Drift mining have flat entries into the coal seam from a hill side. Drift mines are different from slope mines, which have an opening from the surface to the coal vein.*
- *Drifts are driven at just a slight predispose ,so that remove of material may be helped out by gravity.*
- *Drift mining is used to access a range of minerals like gold, coal, quartz and zinc. It possesses high economical means of recovery.*
- *Sub horizontal and horizontal tunnels excavated the side of a mountain or hill given the common name of a drift; are normally driven at an incline or just beneath the vein so that gravity may better assist in the carrying of material out of the mine.*
- *Once tunnels are driven, they may be utilized for haulage, ventilation and exploration of further possible mineral or coal seams.*
- *Material is normally mined and taken out using long-wall mining or room and pillar mining methods and non-stop mining equipment.*
- *This mining process was in fact risky in earlier days. Several tunnels caved in trapping and slaughtering mineral .*
- *Ore was the material which was frequently mined in this manner.*
- *Drift mining it more economical and less invasive way to extracting precious minerals.*

6.0 Rock Burst

Introduction:

- *Rock burst is a sudden violent explosion or dynamic instability of rock fragments and blocks from the surrounding rocks by releasing of strain energy stored in rock mass.*
- *It may bring out greater threats to the underground openings, the equipments and the safety of the mining workers.*

Classification:

1. *Strain burst:* • *Self-initiated, that means sudden release of energy stored in the surrounding rocks.* • *Due to strain energy in highly stressed brittle rocks.*
2. *Fault Slip burst:* • *It is related to shearing on distinct geological feature like faults and dykes.*
3. *Pillar burst:* • *It depends on the size and the location of the pillars in the mine*
 - *Strain burst are frequently encountered with pillar and room mining cavities.*
 - *Naturally induced rock bursts can occur in both an existing or an underground opening being constructed.* • *Most artificially induced (excavating or mining) rock burst occur while an opening is created by around fairly new underground openings.*
 - *Pillar burst is violent failure of pillar and is also a result of local stress redistribution.*
 - *Strain bursting conditions can cause significant cutting problems.*

Causes of rock burst:

- *The cause of rock burst is a combination of stiffness of rock and stresses high enough to exceed the strength of the rock.*
- *The potential of rock burst is higher in homogeneous rock, i.e., rock with less natural discontinuities or with little variation in mineralogy.*
- *Slip along existing discontinuities such as faults, bedding surfaces and interfaces between units.*
- *Propagations of shear fractures in the rock mass ahead of working face.*

- *Presence of faults, dykes or joints.*
- *Earthquakes, volcanic activity and movement of magma, tidal or flood loading or unloading, glacial loading or unloading.*
- *Surface instabilities of the rock mass at the face of the excavation.*
- *Increased depth of mining.*

Prevention:

- *Decrease in rock stiffness.*
- *Greater energy distribution in rock.*
- *Changing layout of excavation to decrease the stresses.*
- *Changing shape of opening.*
- *Using support systems that absorb energy & deform without breaking.*
- *Using destress blasting by drilling, de-stress holes to relieve high stresses present in the rock around the opening.*
- *Slowing the rate of extraction.*
- *A proper planned sequence of stoping for the whole ore body should be adopted.*
- *Avoiding large excavation at depths.*
- *Pillars on volumes of rocks in between excavation should be eliminated or reduced for a minimum.*
- *Stoping should proceed away from a fault or other place of weakness.*
- *Mined out areas should be filled and kept as close to the face as possible.*

FACE MECHANIZATION

LOAD HAUL DUMP (LHD):-

Applicability condition:-

- Gradient should be 1/6.
- It requires strong and good floor.
- It requires strong and good roof.



Description:-

- LHD is a tyre mounted loading machine which takes blasted ore from the face or draw point in its bucket and transports it over a distance and dump it in required place or tubs.
- Being tyre mounted, it runs faster than SDL (at a speed up to 4 km/hr).
- Power to the machine is fed by a trailing cable mounted on cable rill of the machine.
- Being tyre mounted, LHD can work in gradient up to 1/7 where floor is dry & strong.
- Bucket which is fitted in front of the machine may be of 4 types;
 1. Tilting front discharge.
 2. Pusher plate front discharge.

3. Tilting side discharge.
 4. Chain side discharge.
- Bidirectional chain buckets are the most common.
 - LHD is made in two parts which are joined by a flexible joint and can turn up to 100° .
 - It has bucket capacity of 1.5m^3 , 2.7m^3 or 3m^3 .
 - A 1.3m^3 LHD is powered by 50HP/550V FLP motor, it has 100m cable of 38mm outer dia on a cable rill.
 - Recently, in one mine of Singareni, diesel power LHD has been introduced.
 - This is a equipment which perform loading, hauling and discharging of bulk material.

SCRAPER LOADER:-

- This loader is only applicable where relative thick veins or gentle inclined deposits are mined.

Working principle:-

- A double hoist at the loading and transport point moves both the cable with scraper bucket and empty cable through a pulley fixed at the face of heading.
- The scraper bucket which is opened at the end facing conveying direction is automatically loaded by scrapping through material like a prow and is pulled by the haulage cable up to the loading platform to load into a mine car .
- A scraper loader is used for haulage in horizontal, gently steep trackless roadways with stable ground.
- Scraper loaders are widely used in small, medium and large scale mining operations.
- Motor capacity is approximately 1.5 to 5 KN, scrapping capacity is 10 k/hr, transport capacity 15-20m.

JUMBO DRILL WITH AIR LEG:-

- A jumbo drill is a rock drilling machine.

- It consist of 1, 2, 3 carriage, sometimes a platform in which the miners stand to mine load below the face or tunnel.
- The carriage are bolted on to chassis which supports also the miners cabin tends the engine.
- Modern jumbo drill are relatively larger, however smaller ones are also used.
- Modern jumbo are fitted with rubber tyre and diesel powered. There also exist variants with steel wheels to ride on rail.
- Electric power is also common.
- Jumbos are powered by compressed air, electricity and compressed air produces no exert gases which are preferable if work is done in smaller area where there is not good ventilation.
- Jumbo drills are used in underground mines and also in tunnel.

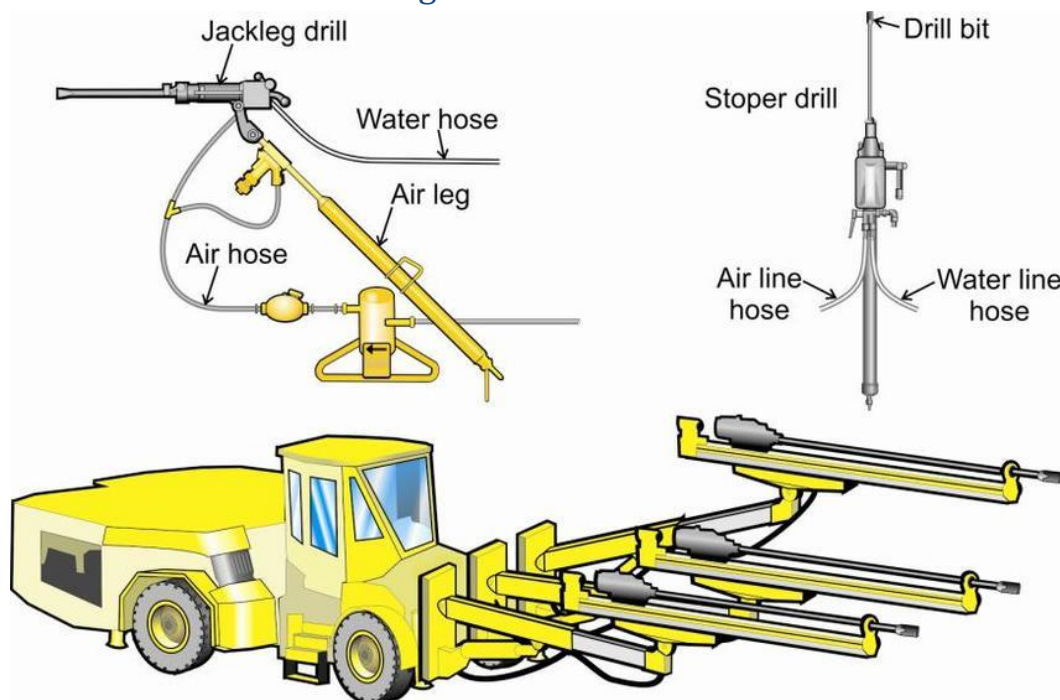

Air leg:-

- Where compressed air is the primary power for drills, air legs maybe used to mount the compressed air drills.
- An air leg is essentially a long cylinder in which a piston is actuated by compressed air controlled valve which is also used to release the air pressure to lower the piston.
- The valve controls the leading pressure on the drill.

- An air leg relieves the operator of the fatigue involved in holding the drill and keeping it pressed forward as the leg exerts an upward lift and a forward feeding pressure on the drill.
- The air leg doesn't increase the rate of penetration of feed and it is used for drifts up to 2m in height.
- In underground mines, drilling rigs or jumbos have to be used for high speed drivage of large size drifts. The terms jumbo and rig are often used synonymously but jumbo is a portable carriage for underground use which has arms for mounting of two or more drills.
- The arms can be raised, lowered and screwed at any angle in position by hydraulic or air pressure and all the drill steels are placed in the carriage.
- A jumbo has a crew of 3-4 operators who performs various operations of setting a drill, drilling, dismantling etc. at the face simultaneously.

ROCKER SHOVEL:-

A Rocker shovel consist of,

1. A chassis
2. A bucket
3. Motor

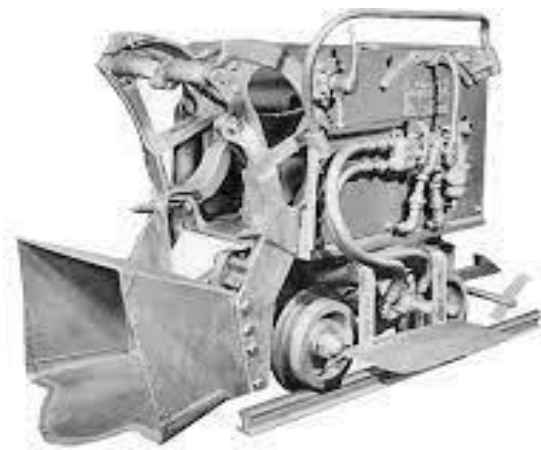

- The crawler chain equipped shovel is based for dipping roadway $\frac{1}{4}$.
- In a rising drift or roadway, a gradient of $\frac{1}{6}$ or more, tyre mounted rocker shovel is preferred.
- A rocker shovel has a bucket or shovel at its front end which may be used for dumping the contents behind it.
- The operator pushes the bucket into the pile of the blasted rock.
- The bucket scoops the materials with an upward and over motion for discharge it into a tub or conveyor behind the loader.

- Such end loader required sufficient headroom height for its upward movement.
- With well fragmented rock in a conventional pile and the tub placed close behind the rocker shovel, the average loading cycle takes about a minute.

SPIRAL CHUTE / STAPLE PIT:-

- Staple pit spiral chutes are introduced for vertical downward transport of ROM (Run of mine) in underground.
- It has very long life, low maintenance and relatively low degradation of product.
- It forms an intermediate bunkering space within the eye of the spiral chute where in the convenient material reaches the bunkering space to the chute.
- It has parallel and vertical walls extending downwardly from the inner and outer edges of the spiral chute.
- It has the advantages of small occupational area, simple structure, no energy consumption, large capacity, easy installation, easy operation and small investment.
- Such spiral chutes are installed in underground mines usually have a diameter of 1250-1650mm.

LOW PROFILE DUMP TRUCK (LPDT):-



- LPDT are usually used at mining and tunneling projects that have steep incline and when hauling distance are no longer feasible for the LHD machine to work on.
- It has 5m³ dump box volume and 1000 kg hauling capacity.
- It is ideal for small to medium size rock excavation operation.
- For medium to large size excavation operation, 10m³ dump box volumes and 20000 kg hauling capacity are used for transporting underground.