



GOVERNMENT POLYTECHNIC JAJPUR

**Laboratory Manual
SURVEYING-II**

Soumya Ranjan Samal

{ Lecture In Mining }

DEPARTMENT OF MINING ENGINEERING

LIST OF EXPERIMENTS:

- 1) Study of theodolite in detail – practice for measurement of horizontal and vertical angles.
- 2) Measurement of horizontal angles by method of repetition and reiteration.
- 3) Trigonometric leveling –heights and distances problem (Two exercises).
- 4) Heights and distance using principles of tachometric surveying (Two exercises).
- 5) Curve setting- different methods. (Two exercises)
- 6) Setting out works for buildings and pipe lines.
- 7) Determine of area using total station.
- 8) Traversing using total station.
- 9) Contouring using total station.
- 10) Determination of remote height using total station.
- 11) Stake out using total station.
- 12) Distance, gradient, diff, height between two inaccessible points using total station.

MANDATORY INSTRUCTIONS

1. Students should report to the labs concerned as per the timetable.
2. Record should be updated from time to time and the previous experiment must be signed by the faculty in charge concerned before attending the lab.
3. Students who turn up late to the labs will in no case be permitted to perform the experiment scheduled for the day.
4. After completion of the experiment, certification of the staff in-charge concerned in the observation book is necessary.
5. Students should bring a notebook of about 100 pages and should enter the readings/observations/results into the notebook while performing the experiment.
6. The record of observations along with the detailed experimental procedure of the experiment performed in the immediate previous session should be submitted and certified by the staff member in-charge.
7. Not more than FIVE students in a group are permitted to perform the experiment on a set up.
8. The group-wise division made in the beginning should be adhered to, and no mix up of student among different groups will be permitted later.
9. The components required pertaining to the experiment should be collected from Lab- in-charge after duly filling in the requisition form.
10. When the experiment is completed, students should disconnect the setup made by them, and should return all the components/instruments taken for the purpose.
11. **Any damage of the equipment or burnout of components will be viewed seriously either by putting penalty or by dismissing the total group of students from the lab for the semester/year.**

12. Students should be present in the labs for the total scheduled duration.
13. Students are expected to prepare thoroughly to perform the experiment before coming to Laboratory.
14. Procedure sheets/data sheets provided to the students groups should be maintained neatly and are to be returned after the experiment.
15. DRESS CODE:
 - i. Boys - Formal dress with tuck in and shoes.
 - ii. Girls - Formal dress (salwar kameez).
 - iii. **Apron in blue color for both boys and girls.**
 - iii. **Wearing of jeans is strictly prohibited**

EXPERIMENT NO -1

STUDY OF THEODOLITE IN DETAIL – PRACTICE FOR MEASUREMENT OF HORIZONTAL AND VERTICAL ANGLES

The theodolite is one of the most precise surveying instruments and is suitable for measurement of angles in horizontal as well as vertical planes.

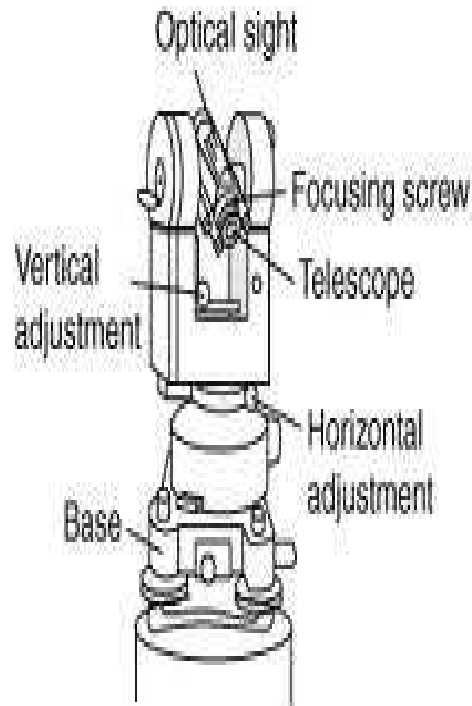

PARTS OF VERNIER THEODOLITE

- 1) **THE LEVELING HEAD:** this usually consists of a tribrach and trivet carrying one foot screw on each of its three arms.
- 2) **THE TWO SPINDLES:** The theodolite has an outer axis and an inner axis of rotation which are both coincident with the vertical axis of the instruments.
- 3) **THE LOWER PLATE AND UPPER PLATE:** the outer axis is attached to the lower plate which is also called the scale plate. This plate is circular in shape and beveled at the edge. It is graduated from 00 to 3600 in the clock wise direction. The inner axis is attached to the upper plate which is also known as the vernier plate. The upper clamp and upper tangent screw facilitate fixing it to the lower plate at any desired position.
- 4) **PLATE LEVEL TUBES:** two level tubes are provided on the vernier plate at right angles to one another. These are known as Plate level.

- 5) **STANDARDS:** A pair of uprights or standards is placed on the vernier plate they support the horizontal axis they are in the shape of letter A.
- 6) **TELESCOPE:** the telescope is fixed to a transverse horizontal axis also known as trunion axis. It rests in bearings on the standards. The telescope can be rotated in a vertical plane about the horizontal axis.
- 7) **VERTICAL CIRCLE:** A vertical graduated circle is rigidly attached to the telescope and rotates along with it. It is graduated from 00 to 3600 continuously or from 00 to 900 in each quadrant.
- 8) **T-FRAME:** Its horizontal arm called index bar has two verniers, one at each end. The vertical leg called the clipping arm has clips screws at its lower end.
- 9) **CAMPASS:** the tubular compass contains a magnetic needle fitted in a metal tube. When the pointer lines exactly midway between these two vertical lines, the magnetic will be defined.
- PLUMB BOB:** the Plumb bob is suspended from the hook fitted to the bottom central vertical axis.
- 10) **THE TRIPOD:** this is the one on which the whole instrument rests when it is on use.

EXPERIMENT NO – 2A

MEASUREMENT OF HORIZONTAL ANGLES BY REPETITION METHOD

Aim: To measure the horizontal angle by the method of repetition .

Instruments required: Theodolite, Tripod, Tape, Ranging Rods, Arrows, Plumb Bob.

Principle:

The method of repetition is used to measure a horizontal angle to a finer degree of accuracy than that obtainable with the least count of the vernier. By this method, an angle is measured two or more times by allowing the vernier to remain clamped each time at the end of each measurement instead of setting it back to zero when sighting at the previous station. Thus an angle reading is mechanically added several times depending upon the number of repetitions.

Procedure:

To measure the angle PQR

1. Set the instrument at Q and level it accurately.
2. With the instrument on the left face, set vernier A to 0^0 and with the aid of the lower clamp and tangent screw bisect signal P. note the reading of verniers A and B.
3. Unclamp the upper clamp and turn the instrument clock-wise towards R and bisect it accurately. Note the reading of verniers A and B.
4. Unclamp the lower clamp and turn the telescope clock-wise to sight P again and bisect it accurately. Note the reading of verniers A and B.
5. Unclamp the upper clamp and turn the telescope clock-wise and sight R and bisect it accurately by upper tangent screw.
6. Repeat the procedure until the angle is repeated the required number of times. The average angle with face left will be equal to final reading divided by three.
7. Change face to right and repeat the above procedure.
8. The average horizontal angle is then obtained by taking the average of the two angles obtained with face left and face right.

Observations:

Instr ume nt at	Sight to	Left face 0° right swing					Right face 0° left swing					Average horizont al angle
		A	B	Mea n	Inclu ded angle	Avera ge includ ed angle	A	B	Mea n	Includ ed angle	Avera ge includ ed angle	
o	A											
	B											

Result: Average horizontal angle by repetition method is -----

EXPERIMENT NO – 2B

MEASUREMENT OF HORIZONTAL ANGLES BY REITERATION METHOD

Aim: To measure the horizontal angle by the method of reiteration .

Instruments required: Theodolite, Tripod, Tape, Ranging Rods, Arrows, Plumb Bob.

Principle:

The method known as direction method or reiteration method or method of series is suitable for the measurements of the angles of a group having a common vertex point. Several angles are measured successively and finally the horizon is closed.

Procedure:

To measure angles AOB, BOC, COD etc.,

1. Set the instrument over O and level it. Set one vernier to zero and bisect point.
2. With the instrument on the left face, loose the upper clamp and turn the telescope clock-wise to point B and bisect it accurately by upper tangent screw. Read both the verniers. The mean of the vernier readings will give the angles AOB.
3. Similarly bisect successively C, D etc., thus closing the circle. Read both the verniers at each bisection. Since the graduated circle remains in a fixed position throughout the entire process by taking the difference between two consecutive readings.
4. On final sight to A, the reading of the vernier should be the same as the original setting. If not the reading and find the error due to slips etc., and if the error is small, distribute it equally to all angles. If large, repeat the procedure and take a fresh set of readings.
5. Change face to right and repeat the above procedure.

SURVEYING-II LABORATORY

Observations:

Instr ume nt at	Sight to	Left face right swing					Right face left swing					Average horizont al angle
		A	B	Mean	Inclu ded angl e	Avera ge includ ed angle	A	B	Mean	Inclu ded angle	Avera ge includ ed angle	
o	A											
	B											
	C											
	D											
	E											

Included angle	Face left	Face right	Average horizontal angle

Result: Average horizontal angle AOB, BOC, COD etc., by reiteration method is -----

EXPERIMENT NO - 3A**TRIGONOMETRIC LEVELLING – ELEVATION OF AN INACCESSIBLE POINT WHOSE BASE IS ACCESSIBLE**

Aim: To find the R.L. of the elevated point when the base of the object is accessible.

Instruments required: Theodolite, Tripod, Tape, Ranging Rods, and Plumb Bob etc.

Principle: Trigonometric levelling is the process of determining the differences of elevations of stations from observed vertical angles and known distances, which are assumed to be either horizontal or geodetic lengths at mean sea level. This method is usually employed when the distance between the instrument station and the base of the object is small. However, if the distance is large, the combined correction for curvature and refraction can be applied.

Procedure:

Let A be the inaccessible point whose elevation is required.

Let B be its projection on the ground which is accessible.

1. Set up the theodolite at C at a distance of D meters from B and level it accurately by the altitude level.
2. With the line of sight horizontal, take a staff reading h on the bench mark established near by the instrument.
3. Sight to point A and observe the vertical angle α subtended at the line of collimation, both on face left and face right and take the average of the two values.
4. Measure the horizontal distance BC accurately by tape.

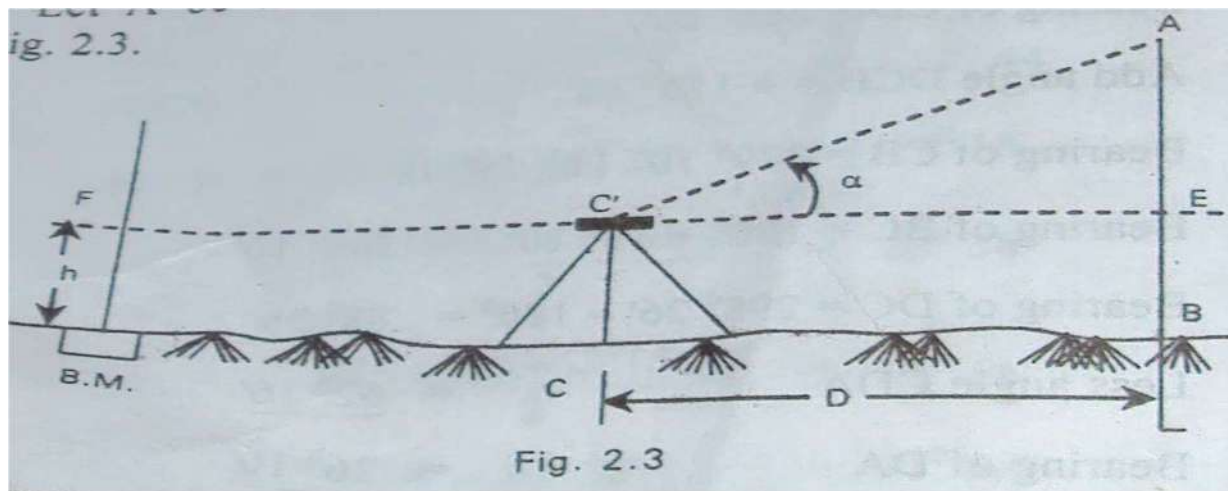

Observations and calculations:

Let C= instrument station

A = point to be observed

C' = Centre of the instrument

E = projection of Q on horizontal plane through A

D = BC = horizontal distance between C and A

h' = height of the instrument at C

h = AE

S = reading of staff kept at B.M., with line of sight horizontal

α = angle of elevation from A to Q

From triangle C'AE ; $h = D \tan \alpha$

R.L. of A = R.L. of instrument axis + $D \tan \alpha$

If the R.L. of C is known,

R.L. of A = R.L. of C + $h' + D \tan \alpha$

If the reading on the staff kept at the B.M. is S with the line of sight horizontal,

R.L. of A = R.L. of B.M. + S + $D \tan \alpha$

If the distance D is large, combined correction for curvature and refraction has to be applied.

R.L of A = R.L of B.M + S + $D \tan \alpha - 0.0673(D/1000)^2$

Instrument at	Sight to	Face left			Face right			Average angle
		C	D	MEAN	C	D	MEAN	

Result: The elevation of the inaccessible point Q is _____

EXPERIMENT NO – 3B**TRIGONOMETRIC LEVELLING – ELEVATION OF AN INACCESSIBLE POINT WHOSE BASE IS INACCESSIBLE**

Aim: To find the R.L. of the elevated point when the base of the object is not accessible.

Instruments required: Theodolite, Tripod, Tape, Ranging Rods, and Plumb Bob etc.

Principle: Trigonometric levelling is the process of determining the differences of elevations of stations from observed vertical angles and known distances, which are assumed to be either horizontal or geodetic lengths at mean sea level. This method is usually employed when the horizontal distance between the instrument and the object can be measured due to obstacles etc., two instrument stations are used so that they are in the same vertical plane as the elevated object.

Procedure:

Let A be the inaccessible point whose elevation is to be determined

- 1) Set up the theodolite at station B at a convenient position so that the object A can be sighted and level the instrument accurately by the altitude level.
- 2) With line of sight horizontal, take the staff readings s_1 on a nearby B.M. to establish the R.L. of the plane of collimation
- 3) Sight object A and read the vertical angle $EB'A = \alpha_1$.
- 4) With both motions of plates clamped, plunge the telescope and mark a station C in the line of sight at a suitable distance d from B so that points, A, B, C lie in the same vertical plane.
- 5) With line of sight horizontal, take the staff readings s_1 on a nearby B.M. to establish the R.L. of the plane of collimation.
- 6) Shift the instrument and set it up exactly over C and level it accurately.
- 7) With line of sight horizontal, take the staff reading s_2 on the B.M. to establish the level of plane of collimation at C.
- 8) Sight object A and read the vertical angle α_2 to A from C.

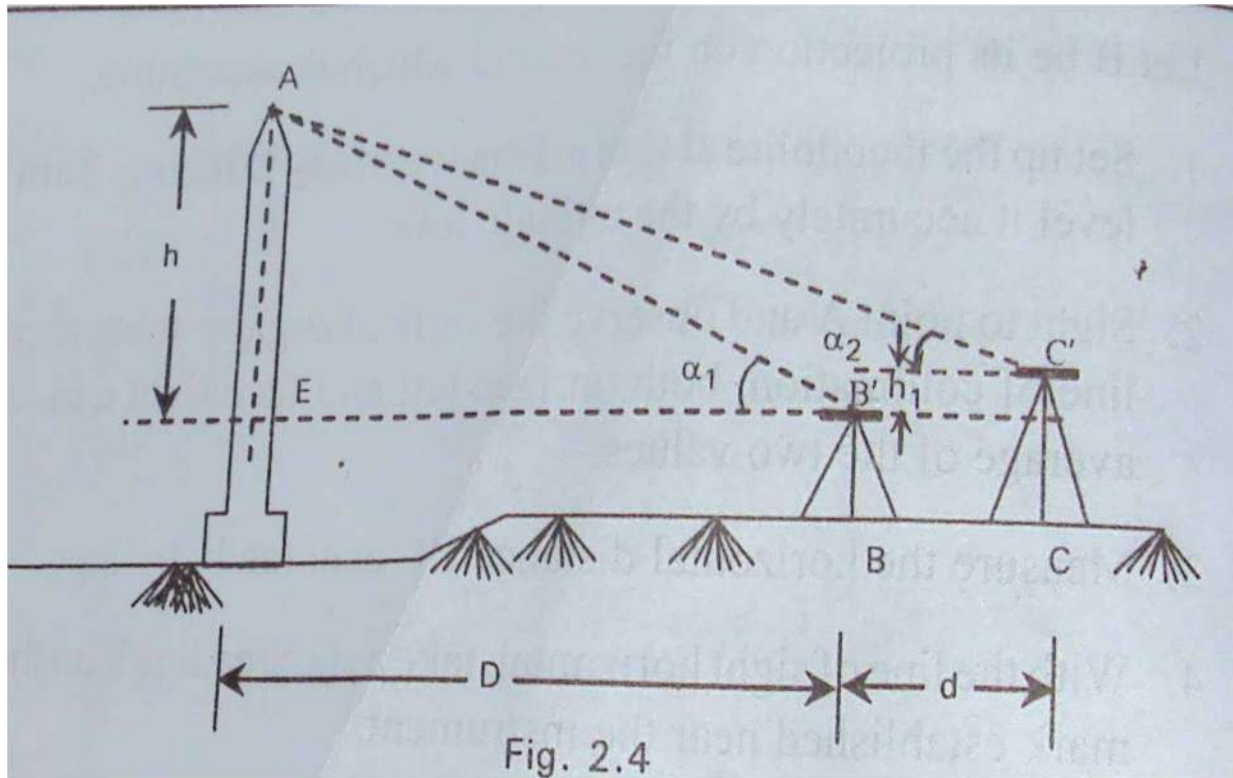

Observations and calculations:

From triangle EB'A, $h_1 = D \tan\alpha_1$ (1)

From triangle FC'A, $h_2 = D \tan\alpha_2$ (2)

Subtracting (2) from (1), we get

$$h_1 - h_2 = D \tan\alpha_1 - (b + D) \tan\alpha_2$$

But $h_1 - h_2 =$ difference in level of instrument axes $= S_2 - S_1 = s$ (say)

$$s = D \tan\alpha_1 - b \tan\alpha_2 - D \tan\alpha_2$$

$$s + b \tan\alpha_2 = D (\tan\alpha_1 - \tan\alpha_2)$$

$$D = \frac{s + b \tan\alpha_2}{\tan\alpha_1 - \tan\alpha_2}$$

From (1), $h_1 = D \tan\alpha_1$

$$h_1 = \frac{s + b \tan\alpha_2}{\tan\alpha_1 - \tan\alpha_2} \tan\alpha_1$$

R.L of A = R.L of B.M + $s_1 + h_1$

R.L of A = R.L of B.M + $s_2 + h_2$

SURVEYING-II LABORATORY

Instrument at	Sight to	Face left			Face right			Average angle
		C	D	MEAN	C	D	MEAN	

Result: The elevation of the inaccessible point Q is _____

EXPERIMENT NO – 4A

HEIGHTS AND DISTANCE USING PRINCIPLES OF TACHEOMETRIC SURVEYING – WHEN BOTH ANGLES ARE IN ELEVATION

Aim: To determine the elevation of an inaccessible point when both angles are in elevation by tacheometric surveying.

Instruments required: Theodolite, tape, cross staff, arrows, tripod etc..

Principle: The Tacheometer is an instrument which is generally used to determine the horizontal as well as vertical distance. It can also be used to determine the elevation of various points which cannot be determine by ordinary leveling. When one of the sight is horizontal and staff held vertical then the RLs of staff station can be determined as we determine in ordinary leveling .But if the staff station is below or above the line of collimation then the elevation or depression of such point can be determined by calculating vertical distances from instrument axis to the central hair reading and taking the angle of elevation or depression made by line of sight to the instrument made by line of sight to the instrument axis.

Observations and Calculations:

- Let P = position of the instrument
- Q = staff station
- M = position of instrument axis
- A, B = position of vanes
- S = distance between the vanes (staff intercept)
- α_1 = angle of elevation corresponding to A
- α_2 = angle of elevation corresponding to B
- D = horizontal distance between P and Q = MQ'
- V = vertical intercept between the lower vane and the horizontal line of sight
- h = height of the instrument of MP
- r = height of the lower vane above the foot of the staff
= staff reading at lower vane = BQ

From triangle MBQ', $V = D \tan \alpha_2$

From triangle AMQ', $V+s = D \tan \alpha_1$

$S = D \tan \alpha_1 - D \tan \alpha_2$

$$D = \frac{s}{\tan \alpha_1 - \tan \alpha_2} = \frac{s \cos \alpha_1 \cos \alpha_2}{\sin(\alpha_1 - \alpha_2)}$$

$$V = D \tan \alpha_2 = \frac{s \tan \alpha_2}{\tan \alpha_1 - \tan \alpha_2} = \frac{s \cos \alpha_1 \sin \alpha_2}{\sin(\alpha_1 - \alpha_2)}$$

Elevation of Q = (Elevation of station + h) + V – r

Procedure:

1. Set up the instrument at P and level it accurately by carryout the temporary adjustments.
2. Set vernier reading to zero making line of sight horizontal.
3. Take the first staff reading on Benchmark and determine height of instrument and let it be h .
4. Then sight the telescope towards the staff station whose R.Ls are to be calculated.
5. Measure the angle on vernier if line of sight is inclined upward or downward and also note the three crosshair readings.
6. Determine the R.Ls of various points by calculating the vertical distance

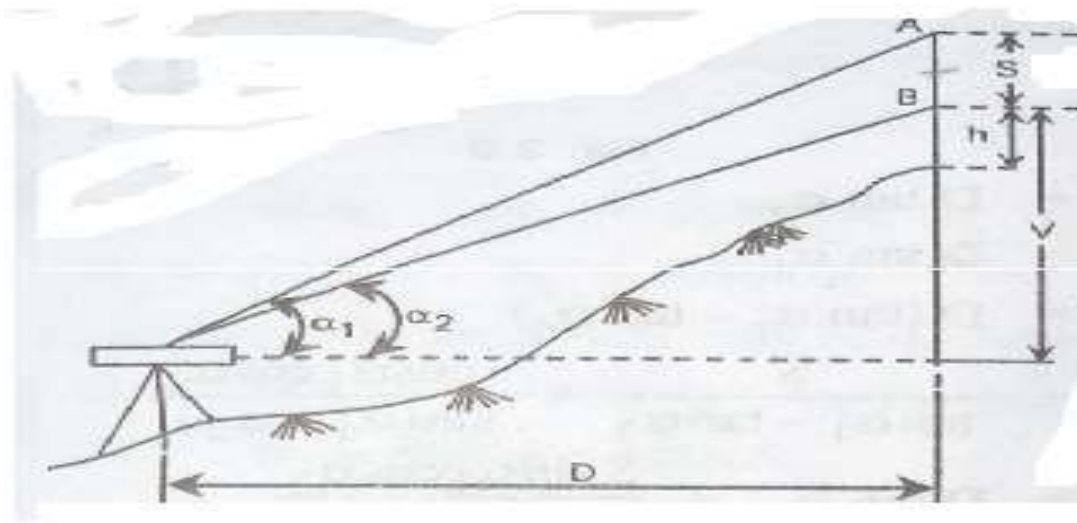

Result: The elevation of an inaccessible point is =

EXPERIMENT NO – 4B**HEIGHTS AND DISTANCE USING PRINCIPLES OF TACHEOMETRIC SURVEYING – WHEN BOTH ANGLES ARE IN DEPRESSION**

Aim: To determine the elevation of an inaccessible point when both angles are in depression by tacheometric surveying.

Instruments required: Theodolite, tape, cross staff, arrows, tripod etc..

Principle: The Tacheometer is an instrument which is generally used to determine the horizontal as well as vertical distance. It can also be used to determine the elevation of various points which cannot be determine by ordinary leveling. When one of the sight is horizontal and staff held vertical then the RLs of staff station can be determined as we determine in ordinary leveling .But if the staff station is below or above the line of collimation then the elevation or depression of such point can be determined by calculating vertical distances from instrument axis to the central hair reading and taking the angle of elevation or depression made by line of sight to the instrument made by line of sight to the instrument axis.

Observations and Calculations:

With the same notations as earlier

$$V = D \tan \alpha_2 \quad \dots\dots(1)$$

$$V-s = D \tan \alpha_1 \quad \dots\dots(2)$$

Subtracting (2) from (1), we get

$$S = D \tan \alpha_2 - D \tan \alpha_1$$

$$D = \frac{s}{\tan \alpha_2 - \tan \alpha_1} = \frac{s \cos \alpha_1 \cos \alpha_2}{\sin(\alpha_2 - \alpha_1)}$$

$$V = D \tan \alpha_2 = \frac{s \tan \alpha_2}{\tan \alpha_2 - \tan \alpha_1} = \frac{s \cos \alpha_1 \sin \alpha_2}{\sin(\alpha_2 - \alpha_1)}$$

Elevation of Q = (Elevation of station + h) - V - r

Procedure:

1. Set up the instrument at P and level it accurately by carryout the temporary adjustments.
2. Set vernier reading to zero making line of sight horizontal.
3. Take the first staff reading on Benchmark and determine height of instrument and let it be h.
4. Then sight the telescope towards the staff station whose R.Ls are to be calculated.
5. Measure the angle on vernier if line of sight is inclined upward or downward and also note the three crosshair readings.
6. Determine the R.Ls of various points by calculating the vertical distance

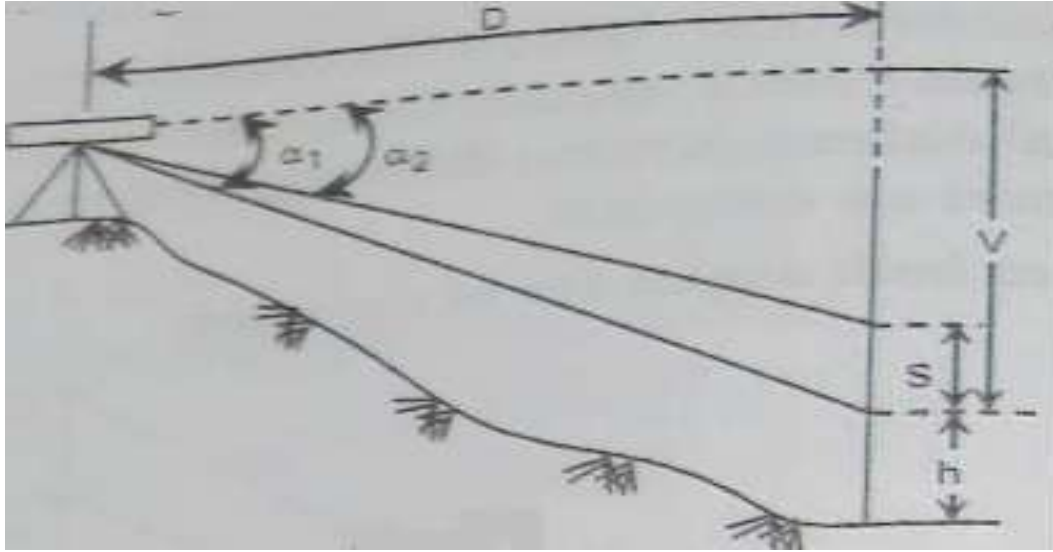

Result: The elevation of an inaccessible point is =

EXPERIMENT NO – 4©

DETERMINATION OF CONSTANTS OF TACHEOMETER

Aim: To determine the multiplying and additive constant of a given theodolite.

Instruments required: theodolite, tape, ranging rods, levelling staff, arrows etc..

Procedure:

1. Stretch the chain in the field and drive pegs at 10m, 20m interval.
2. Set the theodolite at the zero and do the temporary adjustments.
3. Keep the staff on the pegs and observe the corresponding staff intercepts with horizontal site.
4. Substitute the values of distance (D) and staff intercept (s) for different points in the equation $D = ks + C$, where k & s are the tacheometric constants. k is the multiplying constant & C is the additive constant.
5. Solve the successive pairs of equations to get the value of k & C and find out the average of these values.

Observations and calculations:

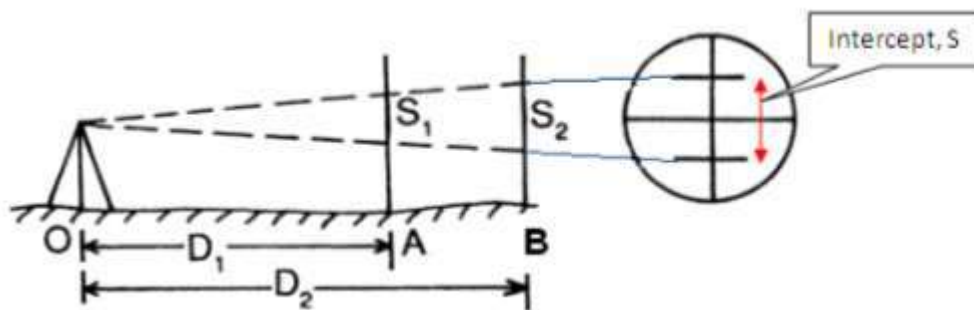

Instrument Station	Staff Station	Distance	Stadia Reading			Stadia Intercept (S)
			Top	Middle	Bottom	

$$D = KS + C$$

$$D1 = K.S1 + C \quad \text{..... (1)}$$

$$D2 = K.S2 + C \quad \text{..... (2)}$$

Solve Two Equations & find K & C

RESULT: Multiplying constant, K =
 Additive constant, C =

EXPERIMENT-5(A)
CURVE SETTING- RANKINE'S METHOD

AIM: To set out a simple curve RANKINE'S method

INSTRUMENTS REQUIRED: Cross staff, arrows, compass, tape, tripod etc.

FIELD PROCEDURE:

- 1) Locate P.C. (T1), P.T (T2) and P.I. (I).
- 2) Set up the theodolite exactly at T1 and make its temporary adjustments.
- 3) Set up vernier A to zero and bisect the P.I Clamp the lower plate.
- 4) Release the upper plate and set the vernier A to read Δ_1 . The line of sight is thus directed along T1a.
- 5) Hold the zero tape at t1, take a distance C1 (T1a) and swing the tape with an arrow till it is bisected by the theodolite. This establishes the first point in the curve.
- 6) Set the second deflection angle Δ_2 . On the scale so that line of sight is set along T1b.
- 7) With zero of the of the tape held at a and an arrow at the other end (chord distance= ab), swing the tape about a, till the arrow is bisected by the theodolite at b, this establishes the second point b on the curve.
- 8) The same steps are repeated till the last point T2 is reached.

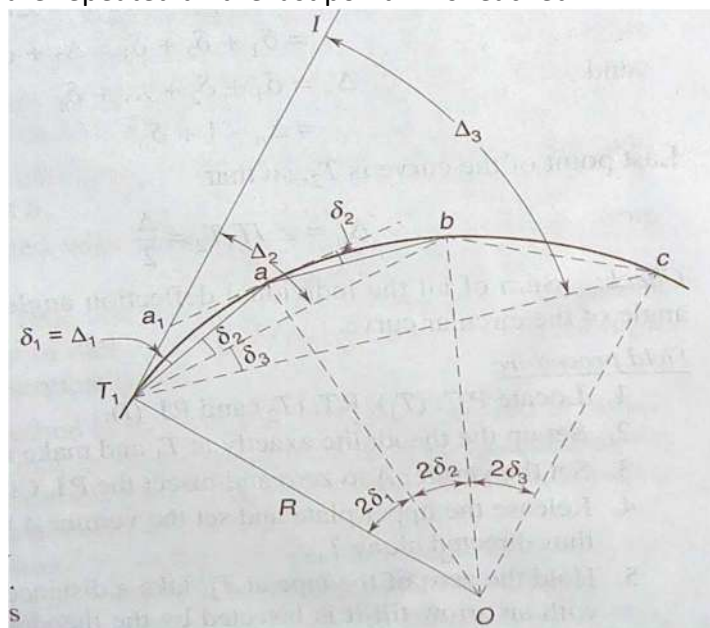

CALCULATIONS:

Now, for the first tangential angle δ_1 , from the property of a circle

$$\text{Arc } T_1 a = R \times 2\delta_1 \text{ radians}$$

Assuming the length of the arc is same as that of its chord, if C_1 is the length of the first chord i.e., chord $T_1 a$, then

$$\begin{aligned} \delta_1 &= \frac{C_1}{2R} \text{ radians} \\ &= \frac{180^\circ C_1}{2\pi R} \text{ degrees} \\ &= \frac{180 \times 60 C_1}{2\pi R} \text{ minutes} \\ &= 1718.9 \frac{C_1}{R} \text{ minutes} \end{aligned}$$

(Note: the units of measurement of chord and that of the radius of the curve should be same).

Similarly, tangential angles for chords of nominal length, say C ,

$$\delta = 1718.9 \frac{C}{R} \text{ minutes}$$

And for last chord of length, say C_n

RESULT: The curve is plotted by using RANKINE'S method.

EXPERIMENT-5(B)

TWO- THEODOLITE METHOD

AIM: Setting the curve by two - Theodolite method.

INSTRUMENTS REQUIRED: Two- theodolites, tape, tripod etc.

PROCEDURE:

- 1) Set up one theodolite at P.C (T1) and the other at P.T (T2).
- 2) Set the vernier A of both the theodolites to zero.
- 3) Direct the theodolite at T1 towards I, and the theodolite at T2 towards T1.
- 4) set angle δ_1 in both the theodolites so as to direct the line of sights towards T1a and T2a, thus the point a ,the point of intersection of the two line of sights ,is established on the curve.
- 5) Similarly, point b is established by setting δ_2 in both the theodolites and bisecting the ranging rod at b.
- 6) The same steps are repeated with different values of δ to establish more points.

This method is expensive and time consuming, but more accurate.

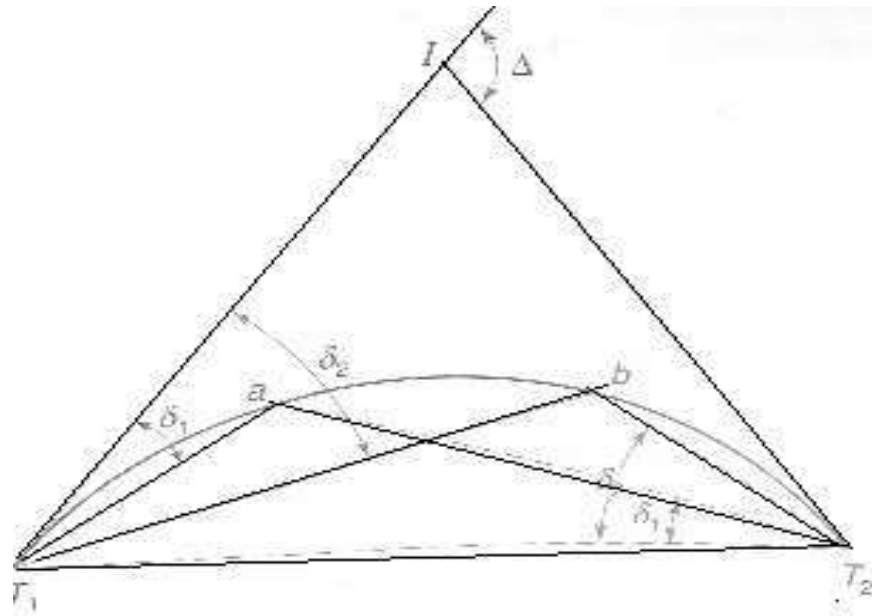

CALCULATIONS:

Now, for the first tangential angle δ_1 , from the property of a circle

$$\text{Arc } T_1 a = R \times 2\delta_1 \text{ radians}$$

Assuming the length of the arc is same as that of its chord, if C_1 is the length of the first chord i.e., chord $T_1 a$, then

$$\begin{aligned} \delta_1 &= \frac{C_1}{2R} \text{ radians} \\ &= \frac{180^\circ C_1}{2\pi R} \text{ degrees} \\ &= \frac{180 \times 60 C_1}{2\pi R} \text{ minutes} \\ &= 1718.9 \frac{C_1}{R} \text{ minutes} \end{aligned}$$

(Note: the units of measurement of chord and that of the radius of the curve should be same).

Similarly, tangential angles for chords of nominal length, say C ,

$$\delta = 1718.9 \frac{C}{R} \text{ minutes}$$

And for last chord of length, say C_n

RESULT: The curve is plotted by using two- theodolite method.

EXPERIMENT NO – 6

SETTING OUT WORKS – FOUNDATION MARKING

Aim: To set out the foundation marking for the proposed construction of the building.

Instruments required: Theodolite, tape, ranging rods, strings, arrows etc..

Principle: The apparatus of the marking on the side, the centre lines of the foundation of the building is called setting out of a foundation.

Procedure:

1. A centre line sketch of building is prepared.
2. The base line is set out with reference to given reference points.
3. The ends of the centre line of the walls point A and point B from the base line are marked.
4. As the end marks A, B, C etc.. are distributed during excavation stakes are fixed at l, m, n etc., a little away about 2 to 3 m from end mark and accurately using string.
5. The centre line for all the other walls AD, BC etc.. are marked by dropping perpendicular by using chain or tape 3:4:5 method for an important and big building when sides are long a theodolite may be employed to accurately set out and range the line.
6. For every wall the pegs are driven a little way from the marking end and field accurately with a string.
7. The diagonals are measured and checked with the corresponding calculated lengths.

RESULT: Thus the centre line planned by being marked on the ground.

EXPERIMENT NO. 7

DETERMINATION OF AREA USING TOTAL STATION

Aim: To determine the given plot's surface area.

Apparatus: Total station and prism with other accessories.

Theory: The computation of areas and volumes are often required in civil engineering practice. One of primary aims of land surveying is to determine the area of land under survey which is usually the property of an individual or institution. In plane surveying the term area refers to the orthogonal projection of ground on a horizontal plane, not actual the ground surface.

Procedure:

1. Make a quick 'eye ball' plan view sketch of the map area in the field book. This will be an important reference to which you later will append information. In plane surveying the term 'area' refers to the orthogonal projection of ground on a horizontal plane, not actual the ground surface.
2. Select a suitable location and setup instrument and do all necessary stationery adjustments.
3. Allocate the soft key from menu.
4. Press to begin surface area calculation.
 - i. Sight the first point on the line enclosing the area.
 - ii. Press [OBS] to begin observation. The measured values are displayed. The function requires each point to be observed individually before area calculation is performed.
 - iii. When [REC] is present registered co-ordinates can be recalled and used in subsequent measurement.
 - iv. Press [OK] to enter the values of the point.
5. Repeat step 4 until all the points have been measured. Points on the enclosed area are observed in a clock-wise or counter clock-wise direction.
6. After all the points which are necessary to calculate the surface area have been observed press [CALC] to display calculated area.
7. Press [OK] to quit area calculation and return to [MEAS] mode.

Result: The area of given plot is _____

EXPERIMENT NO: 8

TRAVERSING USING TOTAL STATION

AIM: To form a closed traverse using total station.

PROCEDURE:

1. Fix the total station over a station and level it
2. press the power button to switch on the instrument.
3. select MODE B -----> S function----->file management----->create(enter a name)-- -
---->accept
4. Then press ESC to go to the starting page
5. Then set zero by double clicking on 0 set(F3)
6. Then go to S function ----->measure ----->rectangular co-ordinate----->station-----> press enter.
7. Here enter the point number or name, instrument height and prism code.
8. Then press accept(Fs)
9. keep the reflecting prism on the first point and turn the total station to the prism ,focus it and bisect it exactly using a horizontal and vertical clamps.
10. Then select MEAS and the display panel will show the point specification
11. Now select edit and re-enter the point number or name point code and enter the prism height that we have set.
12. Then press MEAS/SAVE (F3) so that the measurement to the first point will automatically be saved and the display panel will show the second point.
13. Then turn the total station to second point and do the same procedure.
14. Repeat the steps to the rest of the stations and close the traverse
15. Now go to S function----> view/edit----graphical view.
16. It will show the graphical view of the traverse.

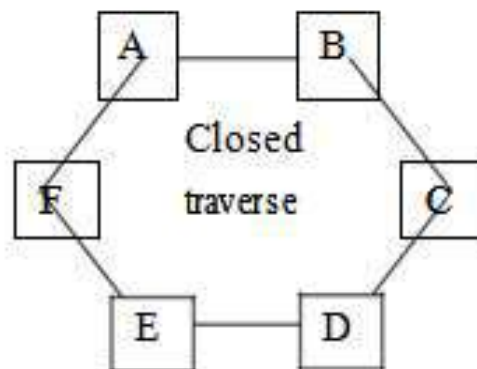

Result: The area of the closed traverse is calculated

SURVEYING-II LABORATORY

EXPERIMENT NO: 9

CONTOURING USING TOTAL STATION

Aim: Counter plan of given area (One full size drawing sheet) using total station.

PROCEDURE:

The elevation and depression and the undulations of the surface of the ground are shown as map by intersection of level surface with by means of contour line. A contour may be defined as the line of intersection of a level surface with the surface of the ground.

1. Fix the total station over a station and level it
2. press the power button to switch on the instrument.
3. select MODE B -----> S function----->file management----->create(enter a name)--
----->accept
4. then press ESC to go to the starting page
5. then set zero by double clicking on 0 set(F3)
6. Then go to S function -----> measure-----> rectangular co-ordinate---->station ---
>press enter.
7. Here enter the point number or name, instrument height and prism code.
8. Then press accept(Fs)
9. Adopt Cross section method for establishing the major grid around the study area.
10. project suitably spaced cross sections on either side of the centre line of the area.
11. Choose several points at reasonable distances on either sides.
12. keep the reflecting prism on the first point and turn the total station to the prism, focus it and bisect it exactly using a horizontal and vertical clamps.
13. Then select MEAS and the display panel will show the point specification

Now select edit and re-enter the point number or name point code and enter the prism height that we have set.

15. Then press MEAS/SAVE (F3) so that the measurement to the first point will automatically be saved and the display panel will show the second point.
16. Then turn the total station to second point and do the same procedure.
17. Repeat the steps to the rest of the stations and get all point details.
18. Plot cross section lines to scale and enter spot levels.
19. The points on the chosen contours are interpolated assuming uniform slope between adjacent points and join them by a smooth line.

Result: The contour of given land is drawn in the sheet.

SURVEYING-II LABORATORY

EXPERIMENT NO. 10

DETERMINATION OF REMOTE HEIGHT USING TOTAL STATION

Aim: To determine height of object whose base is inaccessible.

Apparatus: Total station, tripod and prism with other accessories.

Procedure:

1. Select the suitable location and setup instrument and do all necessary adjustment.
2. Allocate the [REM] soft key from menu.
3. Press the REM to begin the calculation of height.
4. Sight the telescope to base point of target object and press [MEA] and then [REM].
5. Then move the telescope vertically and sight the telescope to the target top point and then lock the telescope. Press stop to stop measurement. The measured distance data displayed.
6. Press [ESC] to finish and return to [MEA] mode screen.

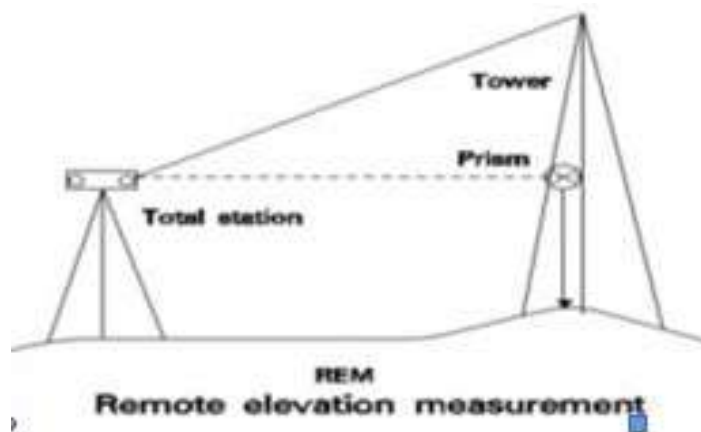

Result: The height of given building is _____

SURVEYING-II LABORATORY

EXPERIMENT NO: 11 STAKE-OUT USING TOTAL STATION

AIM: To find a specific point in the field using Total Station

PROCEDURE

Place the total station in the spot from which you want to stake out points after you have finished entering the coordinates for the area into the total station's internal memory.

1. Make sure that the total station is level and on secure, even ground before continuing.
2. Press the "Power" button to turn on the instrument.
3. Press the "Menu" button and use the navigation arrows to move down to the "Stake Out" menu option. Press the "Select" button to enter the stake out menu.
4. Select the method to stake out the point. Select "XY" to stake out by coordinates which will be the most common method.
5. Press the "Yes" button to continue the process using the coordinates on the screen.
6. If the coordinates are incorrect, press the "No" button to try again.
7. In the next screen, use the keypad to enter the coordinates or distances and press the "OK" button to measure.
8. The results will be displayed on the following screen.

RESULT: The specific point is found.

SURVEYING-II LABORATORY

EXPERIMENT NO. 12

DISTANCE, GRADIENT, DIFFERENCE, HEIGHT BETWEEN ACCESSIBLE STATIONS USING TOTAL STATION

Aim: To determine the distance, gradient, distance, difference, height between accessible stations using total station.

Apparatus: Total station, tripod and prism with other accessories.

Procedure:

1. Select the suitable location and setup instrument and do all necessary adjustment.
2. Allocate the [MLM] soft key from menu.
3. Press the [MLM] to begin the calculation of distance.
4. Sight the target of the starting position and [MEA] and then [MLM].
5. Move the telescope and sight second target then press [MLM] then measured distance data is displayed.
6. Press [ESC] to end missing measurement.

Result: The distance between the two inaccessible points is _____