

---

# POWER STATION ENGINEERING

---

**STUDYMATERIAL**

**Prepared By  
Gitanjali Sethi , Senior Lecturer  
G.P, Jajpur**

**6<sup>TH</sup> SEMESTER, MECHANICAL ENGINEERING**

A power plant can be considered as a machinery setup that produces and delivers a flow of mechanical or electrical energy. Generators are considered as the main equipment for the electric power generation. It generates electricity when it is driven by a prime mover. On the basis of the types of prime movers used, power plants are classified.

The major power plants are,

- Steam power plant
- Diesel power plant
- Gas turbine power plant
- Nuclear power plant
- Hydroelectric power plant

### Sources of Energy:

Energy sources are classified as:

- Conventional Energy Sources or Non-Renewable Energy Sources
- Non-conventional Energy Sources or Renewable Energy Sources

### Conventional Energy Sources:

These sources are finite and exhaustible. Once consumed, these sources cannot be replaced. Examples of these sources are energy from Coal, timber, petroleum, lignite, natural gas, fossil fuels, nuclear fuel etc.

### Non-conventional Energy Sources:

These sources are continuous and non-exhaustible. Examples of these sources are geothermal energy, wind energy, tidal energy, nuclear fusion, bio-energy, solar energy etc. These sources give energy continuously without depletion.

### Captive power stations:

An electricity generation station which is used by an industrial or commercial energy consumer for its own energy consumption is known as a Captive power station. Captive power plants can exchange their surplus energy with the grid.

### Central stations:

An electricity generation station which is not made for the self uses of the industries is known as a Central power station. It generates more power than the captive power plant. It is suitable for large scale power generation. These stations are located outside of the end users and connected to a high voltage transmission network. The electricity generated from these stations are purchased by the consumers.

### Classification of Power Plants:

Conventional Power Plants	Non-Conventional Power Plant
<ul style="list-style-type: none"> <li>➤ Steam/Thermal Power Plants</li> <li>➤ Diesel Power Plants</li> <li>➤ Gas Turbine Power Plants</li> <li>➤ Hydro-Electric Power Plants</li> <li>➤ Nuclear Power Plants</li> </ul>	<ul style="list-style-type: none"> <li>➤ Solar base power plant</li> <li>➤ Wind Energy Power Plant</li> <li>➤ Geothermal Energy</li> <li>➤ Tidal Wave Energy Power Plant</li> <li>➤ Ocean Thermal energy conversion Plant</li> <li>➤ Biogas, Biomass Energy Power Plant</li> <li>➤ Thermoelectric Generator</li> </ul>

## **Importance of Electrical Power:**

The importance of electricity now day is many more than our imagination. In every field there is necessity of electricity. The importance of electric power can be understood from its wide area of application. Some of the most notable uses of electricity are: Entertainment, Healthcare, Engineering, Transport and Communication, Outdoors, Household, Commercial, Office, Fuel and Space etc.

## **Overview of Method of Electrical Power Generation:**

The various sources which are used to generate electric power are discussed below.

### **Steam Power:**

- Steam power plants known as Coal-fired power plants use steam as a source to generate electricity. But the flue gas emitted by the plant to the atmosphere possesses harmful gases and therefore it is not environment friendly.
- But it is now a major electricity generating plant.

### **Hydro Power:**

- The gravitational force of flowing water is utilized in hydro power plants to run the turbines. In these plants, water is forced to possess kinetic and pressure energy which is converted into mechanical energy on the rotation of runner of the hydraulic turbine.
- It is a clean and renewable resource from which electricity is obtained.
- As compared to fossil fuel-powered energy plants, hydroelectric power plants emit fewer greenhouse gases.
- The construction of hydroelectric power plants and dams requires huge investment.

### **Nuclear Power:**

- Nuclear power plants generate a high amount of electricity from a nuclear fission reaction using uranium as fuel.
- Nuclear power plants require low quantities of fuel but produce a large amount of power. Once started, it runs efficiently.
- It is more reliable compared to renewable sources of energy such as solar and wind.
- In these plants, water is converted into steam after receiving heat energy from the nuclear reaction and this steam is used in the turbine for energy conversion.

### **Diesel engine power:**

- This is used for small-scale production of electric power by using diesel as fuel.
- Diesel is a non-renewable source of energy which makes these plants non-durable.
- They are installed in places where there is no easy availability of alternative power sources and are mainly used as a backup for uninterrupted power supply whenever there are outages.
- It is considered as unsuitable for high maintenance costs and diesel prices.

### **Wind Power:**

- Wind turbines capture kinetic energy from wind and convert it into electricity. The amount of energy depends on speed of the wind.
- It is a renewable source of energy.
- Wind power projects typically require huge capital expenditure. After the wind turbines are built, operational costs involved in maintaining wind power plants are low and they are generally considered to be relatively cost-effective.

### **Solar Power:**

- Solar energy plants convert energy from the sun into thermal or electrical energy. It gives the renewable energy sources.
- They do not require high maintenance and last for about 20 to 25 years but requires high initial cost for installation.

**Tidal Power:**

- Tidal energy is generated from converting energy from the force of tides into power. This power is created when tides rotate submerged turbines.
- Its production is considered more predictable compared to wind energy and solar power.
- Tidal power is still not widely used.

**Biomass:**

- Burning organic materials produces high pressure gas that can drive a turbine-generator to make electricity.

**Geothermal energy:**

- Geothermal power plants utilize the internal heat of the earth's crust to heat water to produce steam. This steam gives energy to the turbine-generator to produce electricity.
- Geothermal power plants are considered to be environmentally friendly and emit lower levels of harmful gases compared with coal-fired power plants.

## CHAPTER 2 THERMAL POWER STATION

A thermal power station or a coal fired thermal power plant uses coal as the primary fuel. Heat released from the burning of coal is used to boil the water to make superheated steam for driving the steam turbine. It is the most conventional method of generating electric power with high efficiency.

### Steam Power Plant Layout:

The different types of systems and components used in steam power plant are as follows:

- Boiler
- Turbine
- Condensers
- Cooling tower
- Coal handling system
- Ash handling system
- Draught system
- Feed water treatment plant
- Pumping system
- Mountings like Safety valve, stop valve, pressure gauge and water gauge.
- Accessories like Air preheater, economizer, superheater and feed heaters
- Generator, Transformer and Electricity storage and distribution system

Layout of thermal plant can be easily understood by dividing the plant components into four circuits.

#### ▪ Coal and ash circuit

- Coal and Ash circuit in a thermal power plant layout mainly takes care of supplying the boiler with coal from the storage for combustion and collect the ash from the boiler. Coal storage, preparation and supply to the boiler mainly handled by the coal handling plant whereas the ash collection, storage and disposal mainly handled by the ash handling plant.

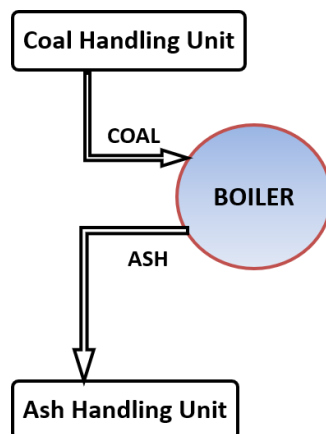

#### ▪ Air and gas circuit

- Air and gas circuit in a thermal power plant layout mainly takes care of supplying preheated air obtained from the Air preheater to the furnace and releasing the exhaust gas from the furnace after the combustion of fuel.
- Atmospheric air is drawn into the Air preheater through the forced draught fan where air is heated by the hot flue gas coming out from the furnace.
- Flue gas having very high temperature is used in the super heater, economizer and air preheater where its heat is recovered. After that the flue gas passes through the electrostatic precipitator for removing dust from the gas and then gas is drawn into the chimney by the induced draught fan to release the gas to atmosphere.

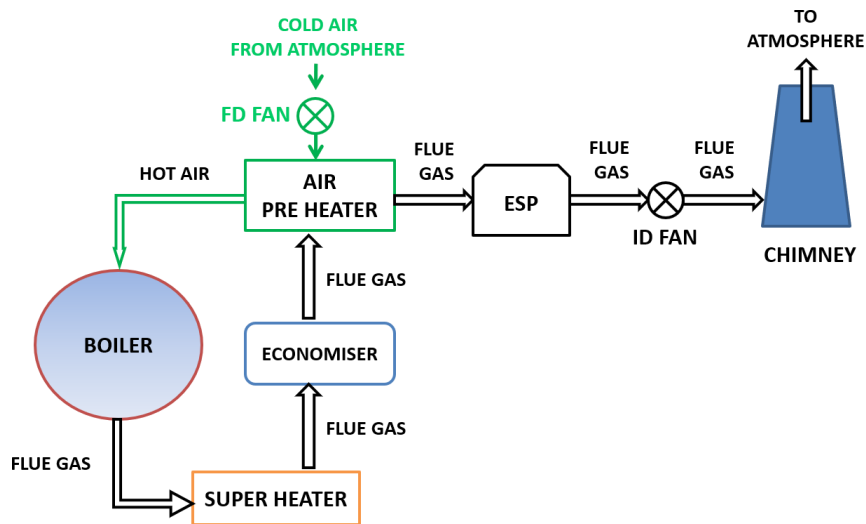

▪ **Feedwater and steam circuit**

- The water and steam circuit in a thermal power plant layout mainly takes care of feeding hot water obtained from the economizer to the boiler and supplying steam obtained from the boiler to the turbine to generate power.
- The steam that is expelled by the prime mover in the thermal power plant layout is then condensed in a condenser for re-use in the boiler. The condensed water is forced through a pump into the feed water heaters. Pre heated water is supplied into the boiler. To make up for the lost steam and water, makeup water is fed to the boiler.

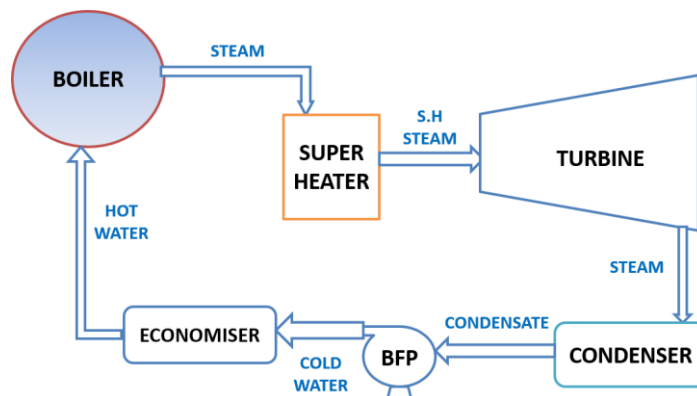

▪ **Cooling water circuit**

- Cooling water is passed through the condenser where the steam is condensed. The water after being heated by steam is discharged to Cooling tower. Cooling water circuit can also be a closed system where the cooled water is sent through cooling towers for re-use in the power plant. The cooling water circulation in the condenser of a thermal power plant layout helps in maintaining a low pressure in the condenser.

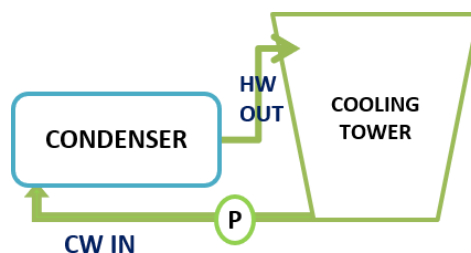

In a steam power plant, Steam is generated in a boiler, expanded in the prime mover and condensed in the condenser and fed into the boiler again. The layout of steam power plant is given below.

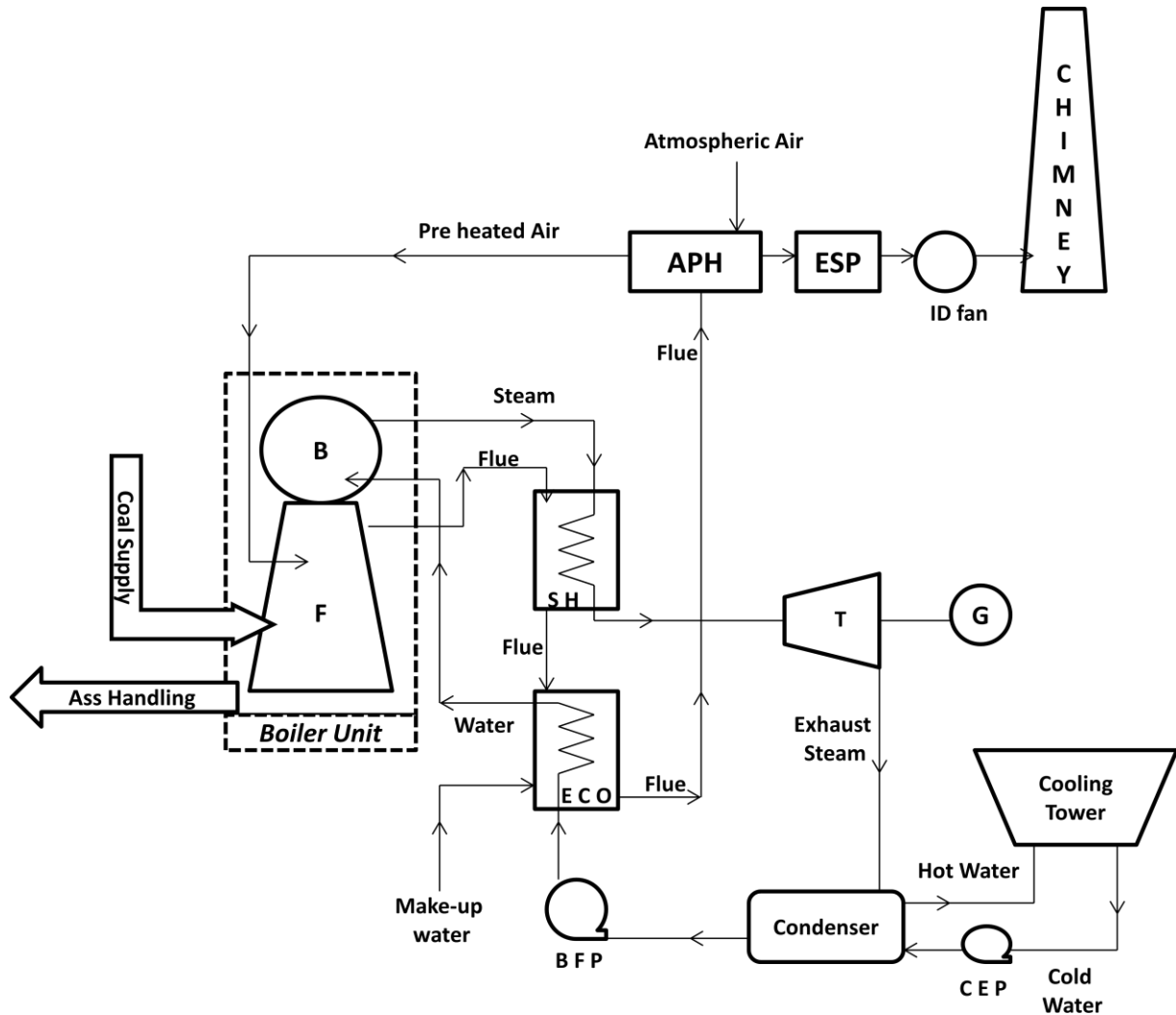

### Carnot vapour power cycle:

The P-V and T-s diagram for Carnot vapour cycle is shown below.

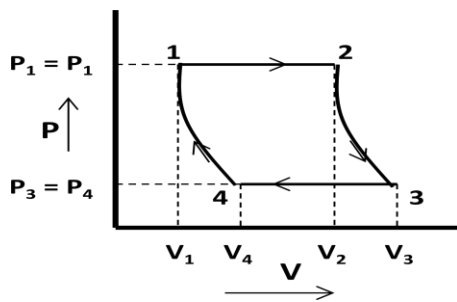

(P-V diagram)

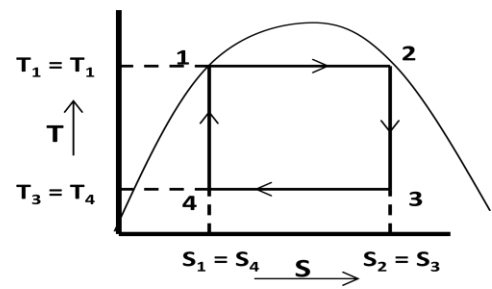

(T-s diagram)

Carnot vapour cycle consists of the four processes as described below.

- **Isothermal expansion:**

In figure process 1-2 shows the isothermal expansion process. In this process water gets heated in the boiler at constant temperature ( $T_1 = T_2$ ) and pressure ( $P_1 = P_2$ ) and gets converted into steam. Entropy increases from  $s_1$  to  $s_2$  and dry steam is collected at state 2.

Heat absorbed by water ( $Q_{1-2}$ ) =  $T_1(s_2 - s_1)$

- **Reversible adiabatic expansion:**

In figure process 2-3 shows the reversible adiabatic expansion process. In this process steam expands inside the turbine at constant entropy ( $s_1 = s_2$ ) and produces shaft power. Steam becomes wet at state 3. Pressure and temperature get changed from state 2-3.

- **Isothermal compression:**

In figure process 3-4 shows the isothermal compression process. In this process steam gets condensed in the condenser at constant temperature ( $T_3 = T_4$ ) and pressure ( $P_3 = P_4$ ). Entropy decreases from  $s_3$  to  $s_4$  and wet steam is collected at state 3. Heat rejected from steam ( $Q_{3-4} = T_3(s_3 - s_4) = T_3(s_2 - s_1)$ )

- **Reversible adiabatic compression:**

In figure process 4-1 shows the reversible adiabatic compression process. In this process wet steam at state 4 gets compressed to state 1 at constant entropy ( $s_4 = s_1$ ) in feed pump. Pressure and Temperature get changed from state 4-1.

**Efficiency of Carnot Cycle:**

$$\text{Efficiency} = \eta_{\text{Carnot}} = \frac{\text{Work done}}{\text{Heat Supplied}} = \frac{\text{Heat supplied} - \text{heat rejected}}{\text{Heat supplied}} = \frac{Q_{1-2} - Q_{3-4}}{Q_{1-2}} = \frac{T_1(s_2 - s_1) - T_3(s_2 - s_1)}{T_1(s_2 - s_1)} = \frac{T_1 - T_3}{T_1} = 1 - \frac{T_3}{T_1}$$

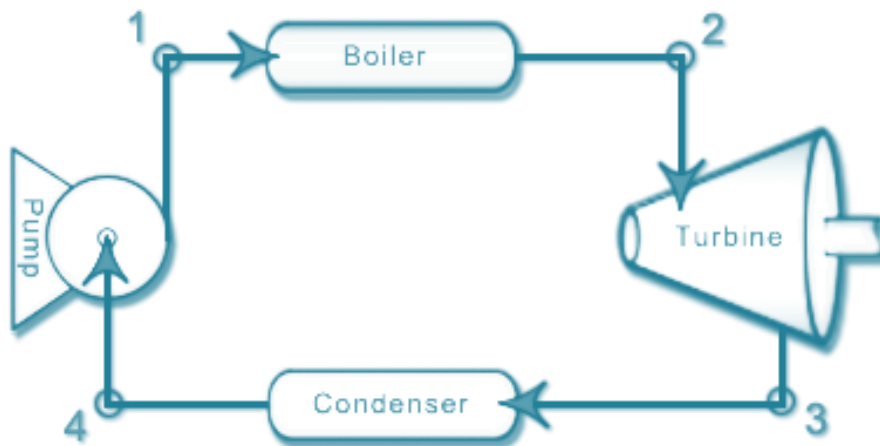

(Simple steam power plant working on Carnot cycle)

The limitations of Carnot vapor cycle are

- It is difficult to compress a wet vapor isentropically to the saturated state (process 4-1).
- It is difficult to control the quality of the condensate coming out of the condenser.
- The efficiency of the Carnot cycle is greatly affected by the temperature  $T_1$ .
- The cycle is still more difficult to operate in practice with superheated steam.



## Rankine cycle:

A steam power plant using steam as working substance works basically on Rankine cycle. The T-S diagram for Rankine cycle is shown below.

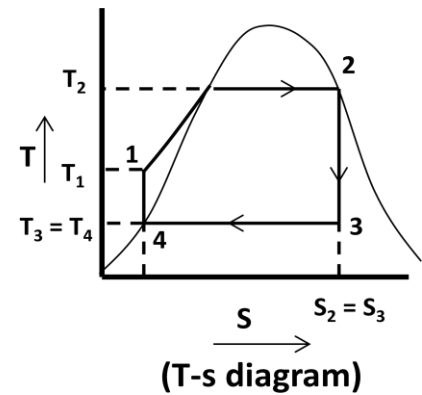
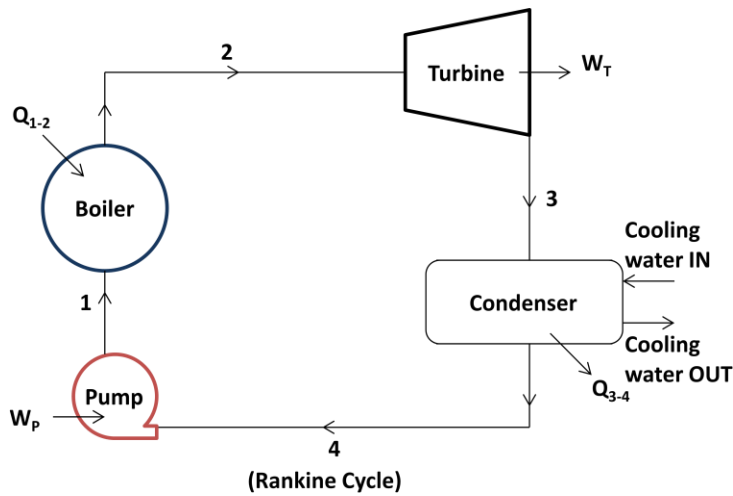

Rankine cycle consists of the four processes as described below.

- **Isothermal expansion:**

In figure process 1-2 shows the isothermal expansion process. In this process saturated water at state 1 is converted into dry saturated steam at state 2 in a steam boiler at constant pressure ( $P_1 = P_2$ ). Water absorbs the latent heat of vaporization ( $h_{fg1} = h_{fg2}$ ) and is converted into dry saturated steam.

$$\text{Amount of heat absorbed in process 1-2} = h_{fg2} = h_2 - h_{f2} \quad (\text{for dry steam: } h_2 = h_{fg2} + h_{f2})$$

- **Reversible adiabatic or Isentropic expansion process:**

In figure process 2-3 shows the reversible adiabatic or isentropic expansion process. In this process dry saturated steam at state 2 expands isentropically in a turbine to state 3. Steam at state 3 is wet.

$$\text{Work done in the process 2-3} = \text{Turbine work} = h_2 - h_3$$

- **Isothermal compression process:**

In figure process 3-4 shows the isothermal compression process. In this process exhaust steam of turbine is cooled by cold water in the condenser at constant pressure ( $P_3 = P_4$ ) and constant temperature ( $T_3 = T_4$ ). Steam releases latent heat of vaporization and is converted into saturated water.

$$\text{Amount of heat rejected in process 3-4} = h_{fg3} = h_3 - h_{f4}$$

- **Reversible adiabatic or Isentropic process:**

In figure process 4-1 shows the reversible adiabatic or isentropic process. In this process saturated water is drawn by the pump and fed into the boiler.

$$\text{Work done in this process 4-1} = \text{Pump work} = h_1 - h_{f4}$$

### Efficiency of Rankine cycle:

$$\text{Efficiency} = \frac{\text{Net Workdone}}{\text{Heat Supplied}} = \frac{W_T - W_P}{Q_{1-2}} = \frac{(h_2 - h_3) - (h_1 - h_{f4})}{(h_2 - h_{f1})}$$

If pump work is neglected then  $W_P = 0$

## Various end conditions of steam:

The T-S diagram for various end conditions of steam can be discussed by the Rankine cycle.

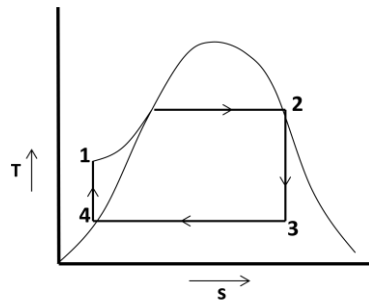

(Steam is dry at state 2)

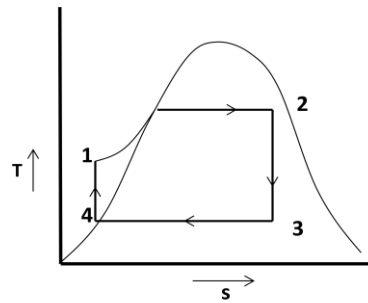

(Steam is wet at state 2)

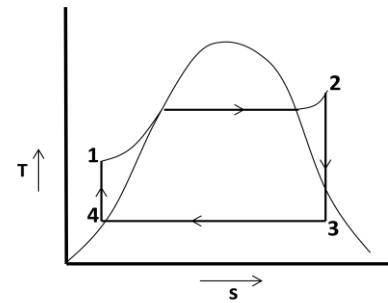

(Steam is superheated at state 2)

- **Efficiency ratio:**

It is the ratio of thermal efficiency to Rankine efficiency or actual cycle efficiency to ideal cycle efficiency.

$$\text{Efficiency ratio} = \frac{\text{Thermal efficiency Rankine}}{\text{efficiency}}$$

- **Thermal efficiency:**

$$\text{Thermal efficiency} = \frac{3600 \times P}{m(h_2 - h_{f3})}$$

Where, P = power developed in kW and m = mass of steam supplied

- **Work ratio:**

It is the ratio of net work done to the turbine work.

$$\text{Work ratio} = \frac{\text{Turbine work} - \text{Compressor work}}{\text{Turbine work}}$$

- **Specific steam consumption:**

It is defined as the mass of steam supplied to the turbine to develop unit power output. It is also known as steam rate or specific rate of flow of steam.

$$\text{Specific steam consumption} = \frac{3600}{h_2 - h_3} \text{ kg/kWh}$$

## Problems:

- Q.1) In a steam power cycle, the steam supply is at 15 bar and dry and saturated. The condenser pressure is 0.4 bar. Calculate the Carnot and Rankine efficiencies of the cycle. Neglect pumpwork.
- Q.2) A simple Rankine cycle works between pressures 28 bar and 0.06 bar, the initial condition of steam being dry saturated. Calculate the cycle efficiency, work ratio and specific steam consumption.
- Q.3) A steam turbine receives steam at 15 bar and  $350^{\circ}\text{C}$  and exhausts to the condenser at 0.6 bar. For the ideal Rankine cycle operating between these two limits, determine the (i) heat supplied, (ii) heat rejected, (iii) net work done (iv) thermal efficiency.
- Q.4) Steam at 50 bar and  $400^{\circ}\text{C}$  expands in a Rankine cycle to 0.5 bar. For a mass flow rate of 150 kg/s of steam determine (i) power developed, (ii) thermal efficiency, (iii) specific steam consumption.
- Q.5) Dry and saturated steam at 15 bar is supplied to a steam turbine working in Rankine cycle. The exhaust takes place at 1 bar. Calculate (i) Rankine efficiency, (ii) steam consumption per kWh if the efficiency ratio is 0.65.
- Q.6) A turbine working on a Rankine cycle is supplied with dry saturated steam at 25 bar and exhaust takes place at 0.2 bar. For a steam flow rate of 10 kg/s, estimate –  
(i) quality of steam at the end of expansion, (ii) turbine shaft work, (iii) power required to drive the pump, (iv) work ratio, (v) Rankine efficiency, (vi) heat flow in condenser.

## **Boiler Accessories:**

Boiler accessories are these set of devices that are used to increase the efficiency of the boiler. These devices improve the boiler operation. The following are some of the accessories which are used in boiler.

### **▪ Air preheater:**

- It is a heat exchanger which converts the cold air into hot air from the heat exchange between atmospheric air and flue gas.
- It recovers heat from the flue gas coming out of the Economizer.
- It is installed between the economizer and the chimney.
- The air required for the purpose of combustion is drawn through the air preheater where its temperature is raised. It is then passed through ducts to the furnace.
- The preheated air gives higher furnace temperature which results in more heat transfer to the water and thus increases the evaporative capacity per kg of fuel. It increases the boiler efficiency.

### **▪ Economizer:**

- It is a heat exchanger which converts the cold water into hot water from the heat exchange between feed water and flue gas.
- It recovers heat from the flue gas coming out of the superheater.
- It improves the economy of the steam boiler.

### **▪ Superheater:**

- It is a heat exchanger which converts the steam coming from the boiler into superheated steam from the heat exchange between steam and flue gas.
- It recovers heat from the flue gas coming out of boiler.
- Its purpose is to increase the temperature of saturated steam without raising its pressure. It is generally an integral part of a boiler which is located in the path of hot flue gases from the furnace.

### **▪ Electrostatic precipitator:**

- It uses electrostatic force to separate dust particles from exhaust gases.
- The contaminated exhaust gas flow through the passage formed by a number of high-voltage, direct-current discharge electrodes and grounded collecting electrodes.
- The airborne particles receive negative charge while passing through the ionized field between the discharge and collecting electrodes.
- These charged particles get attracted toward the positively charged grounded or collecting electrode and adhere to it.
- The collected material on the collecting electrode is removed by rapping or vibrating the collecting electrodes.

## Need of boiler mountings:

Boiler mountings are these set of safety devices installed on the boiler for its safe operation. These are very essential for a boiler to operate it safely.

The following are some of the mountings which are used in boiler.

- *Pressure Gauge*: It is used to measure the pressure of steam inside the boiler.
- *Water level Indicator*: It is used to indicate the water level in the boiler.
- *Safety Valve*: It is used to blow off the excess steam when steam pressure reaches above safety level.
- *Steam Stop Valve*: It is used to stop the steam in the boiler and transfer steam when it is required.
- *Blow off Valve*: It is used to blow off the impurities or sediments settled down in the boiler.
- *Feed check Valve*: It is used to control the flow of water from feed pump to the boiler.

## Operation of boiler:

- The boiler is a closed vessel. The basic function of boiler is to convert water into steam. Water is supplied into the boiler drum where it is heated by hot gases that are formed by burning fuel in the furnace. When the steam at required pressure is generated inside the boiler, the steam stop valve releases the steam. This steam is superheated in a superheater before it is supplied into the turbine.
- The various mountings and accessories of boiler help to run the boiler safely and to improve plant efficiency respectively.

## Draught systems:

- Boiler draught is the pressure difference between absolute gas pressure within a furnace or chimney and atmospheric pressure which causes the flow of gas.
- Draught can be obtained by the use of chimney, fan, steam or air jet or a combination of these.
- Boiler Draught provides an adequate supply of air for fuel combustion. It can throw out the exhaust gases of combustion from the combustion chamber. It can discharge flue gases to the atmosphere through the chimney.
- The draughts may be classified as Natural Draught and Artificial Draught.

## Natural Draught:

- When the draught is produced with the help of chimney only, it is known as Natural Draught.
- Natural draught system employs a tall chimney and doesn't require any external power for producing draught.

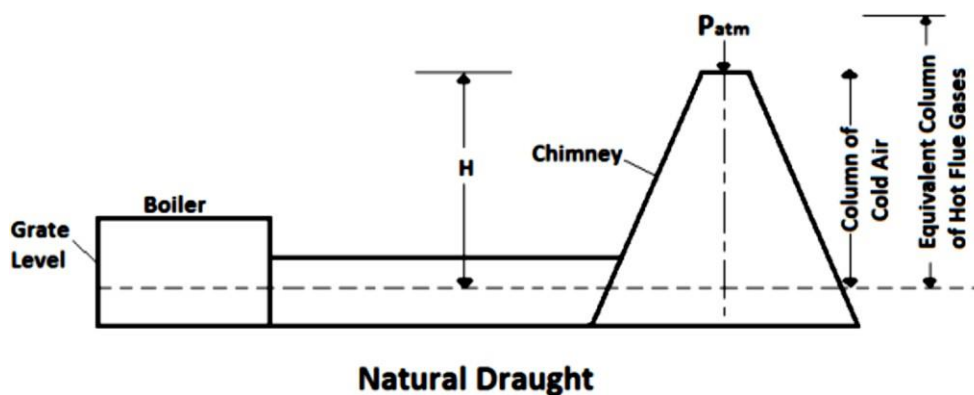

### ▪ Advantages of Natural Draught

- It is produced with the help of chimney only. It does not require any external power for producing the draught.
- It has low capital and maintenance cost.
- Simple in design and construction.
- It has a long life. It leaves the flue gas at a high level.

### ▪ Disadvantages of Natural Draught

- Maximum pressure available for producing draught by the chimney is less.
- The available draught decreased with increase in outside air temperature.
- Flue gases have to be discharged at high temperature which lowers the plant overall efficiency.

### Artificial Draught:

- When the draught is produced by any other means except chimney it is known as Artificial Draught.
- To meet the high draught demand, artificial draught system is used which is classified as steam jet draught and mechanical draught.

### Mechanical Draught:

- It is an artificial draught where draught is produced by the help of fans or blowers.
- It is more economical and its control is easy.
- It increases the rate of combustion by which low-grade fuel can also be used.
- It reduces fuel consumption and makes boiler operation cheaper.
- It can be classified as Forced draught, Induced draught and Balanced draught.

### Forced draught:

- In this type of draught, a blower known as forced draught fan (FD fan) is placed before the grate. It forces the air into the grate through the closed ash pit. Air is forced to flow through the entire system under pressure.

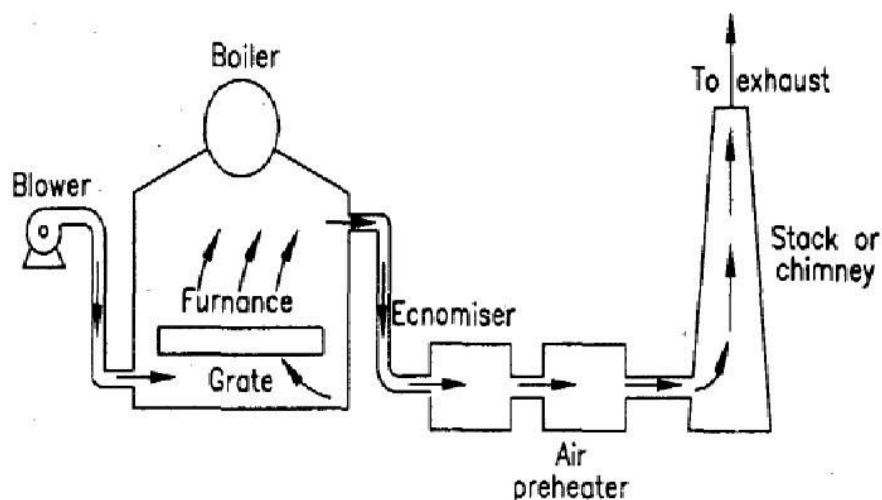

### Induced draught:

- In this type of draught, a centrifugal fan known as induced draught fan (ID fan) is placed near the base of the chimney. The ID fan draws the furnace flue gas and forces the gas up through the chimney. Its action is similar to that of the natural draught.

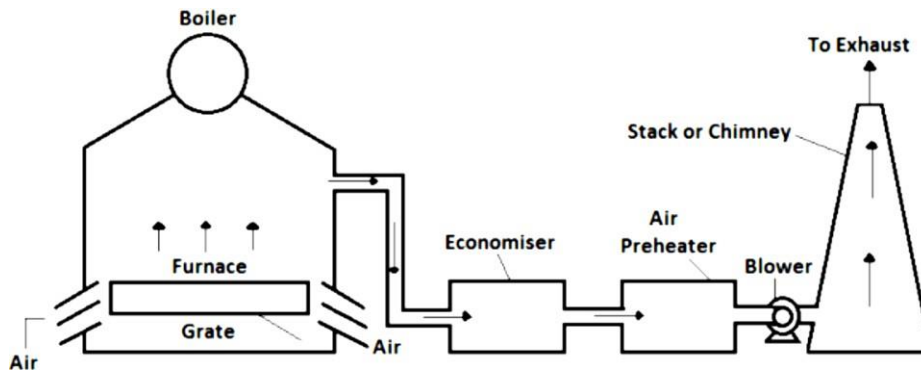

### Balanced draught:

- Balanced draught is the combination of forced draught and induced draught.
- It overcomes the difficulties that are seen by using the forced draught or induced draught alone. It maintains the balance.
- The forced draught fans supply the combustion air for better combustion of fuel and overcome the resistance of fuel bed.
- The induced draught removes the flue gas and excess air from the furnace and helps to release it through the chimney. It helps to maintain the pressure inside the furnace below atmospheric.
- If the forced draught is applied alone, there will be high pressure in the furnace. It causes difficulties in lighting and inspecting the boiler. There is a possibility of blowing out of fire from the furnace which may disable the furnace work.
- If the induced draught is used alone, there will be difficulties in inspecting the boiler because cold air may rush into the furnace as the pressure inside the furnace is under atmospheric pressure.

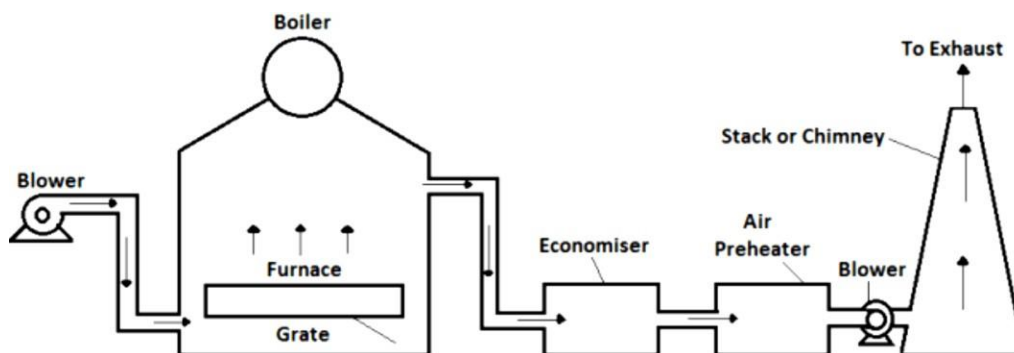

### Advantages of Artificial or Mechanical Draught

- It increases the rate of combustion for which low-grade fuel can be used in the furnace. So, fuel cost is reduced.
- The desired value of draught can be produced, which is not obtained in natural draught.
- It reduces the smoke level and reduces the height of chimney.
- It is more economical and its control is easy.
- It saves the energy. It improves plant efficiency as a maximum heat can be utilized.
- It reduces fuel consumption and makes boiler operation cheaper.

### **Disadvantages of Artificial or Mechanical Draught:**

- The initial cost is high.
- The running cost is also high due to consumption of electricity but it is compensated by other savings.
- Fans and blowers produce noise.

### **Steam prime mover or Steam Turbine:**

The steam turbine is used to convert the thermal energy of steam into mechanical energy by means of rotation of turbine shaft. This mechanical energy is used by generator to produce electrical energy.

The steam coming from the boiler rotates the turbine runner when it strikes on it. Thus, mechanical energy is produced due to rotation of shaft of the turbine. When the turbine shaft rotates, the generator shaft coupled to the turbine shaft is also rotated.

### **Advantages of steam turbine:**

- It has higher thermal efficiency.
- It can provide a good range of uniform brake horsepower.
- It is properly balanced and so, vibration problem is minimized.
- It gives high rpm.
- It is reliable and durable.
- It needs no lubrication.

### **Disadvantages of steam turbine:**

- It is less responsive to changes in power demand compared to reciprocating engines and gas turbines.
- It takes long startup time compared to reciprocating engines and gas turbines.
- It is less efficient at part load conditions than reciprocating engines and gas turbines.

### **Classification of steam turbine:**

The steam turbines may be classified into the following types:

- According to the mode of steam action
  - Impulse turbine
  - Reaction turbine
- According to the direction of steam flow
  - Axial flow turbine
  - Radial flow turbine.
- According to the exhaust condition of steam
  - Condensing turbine
  - Non-considering turbine
- According to the pressure of steam
  - High pressure turbine
  - Medium pressure turbine
  - Low pressure turbine
- According to the number of stages
  - Single stage turbine
  - Multi stage turbine



## Elements of steam turbine:

The components of steam turbine are

- **Steam Chest and Casing:**
  - The casing contains the rotor and nozzle through which the steam is expanded.
  - The steam chest is connected with the high pressure and low-pressure steam lines.
  - The steam chest and casing protect the turbine from surrounding.
  - It encloses the steam inside the turbine.
- **Nozzles:**
  - These are used to increase the kinetic energy of steam.
- **Rotor:**
  - The rotor consists of disc mounted on a shaft. Number of blades are mounted on the periphery of the disc.
  - The shaft extends beyond the casing. One end of the shaft is connected with the governor and other end is coupled with the shaft of the generator.
  - The main function of the rotor is to convert the thermal energy of the incoming steam into kinetic energy.
- **Blades**
  - Number of blades mounted on the periphery of the disc are used to receive the steam on it. These are used for energy conversion and pressure and velocity variation.
- **Governor**
  - It is used to maintain the mean equilibrium speed of the steam turbine.

## Difference between Impulse and reaction turbine:

### Impulse turbine

1. The steam flows through the nozzles and impinges on the moving blades.
2. The steam impinges on the buckets with kinetic energy.
3. The steam may or may not be admitted over the whole circumference.
4. The steam pressure remains constant during its flow through the moving blades.
5. The negative velocity of steam while gliding over the blades remains constant.
6. The blades are asymmetrical.
7. The number of stages required is less for the same power developed.

### Reaction turbine

1. The steam flows first through the guide mechanism and then through the moving blades.
2. The steam glides over the moving vanes with high pressure and kinetic energy.
3. The steam must be admitted over the whole circumference.
4. The steam pressure is reduced during its flow through the moving blades.
5. The relative velocity of steam while gliding over the moving blades increases.
6. The blades are not symmetrical.
7. The number of stages required is more for the same power developed.

## Governing of Steam turbine:

- The function of a governor is to control the fluctuation of speed of a steam turbine.
- When the steam turbine is connected to drive an alternator, there may be variation of load. According to the load on the alternator, turbine speed fluctuates. This fluctuation can be overcome by using a governing method.
- The different governing methods are:
  - Throttle governing
  - By-pass governing
  - Nozzle governing

### Throttle Governing:

- This method is very simple and less costly. This is used to reduce inlet steam pressure by a throttle valve operated by governing mechanism on part loads.
- An oil relay is used to operate the throttle valve.
- When the turbine works on less than full load condition, the load on the turbine suddenly released, governor speed increases with rotor speed and sleeve moves upward. So, relay piston under oil pressure moves downward and partially closes throttle valve. Then the sleeve comes to its position when equilibrium speed is obtained.

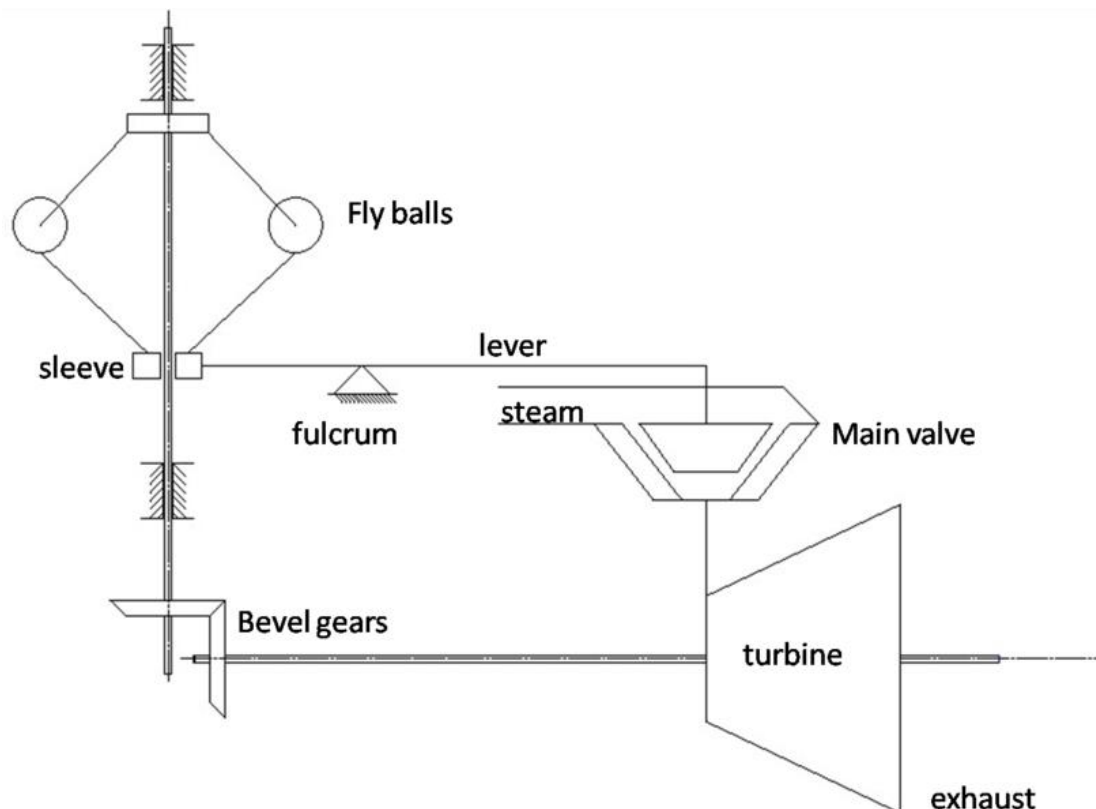

### By-pass Governing:

- This method is used in modern impulse turbine operating at a very high pressure.
- In this method the whole steam enters the nozzle box through a throttle valve. This valve controls the speed of turbine for all load up to economical load. For the loads more than economical load, the by-pass valve opens and allows the steam to pass from the first stage nozzle box into steam belt and so into the fourth stage nozzle. When the load stabilizes, the valve closes.

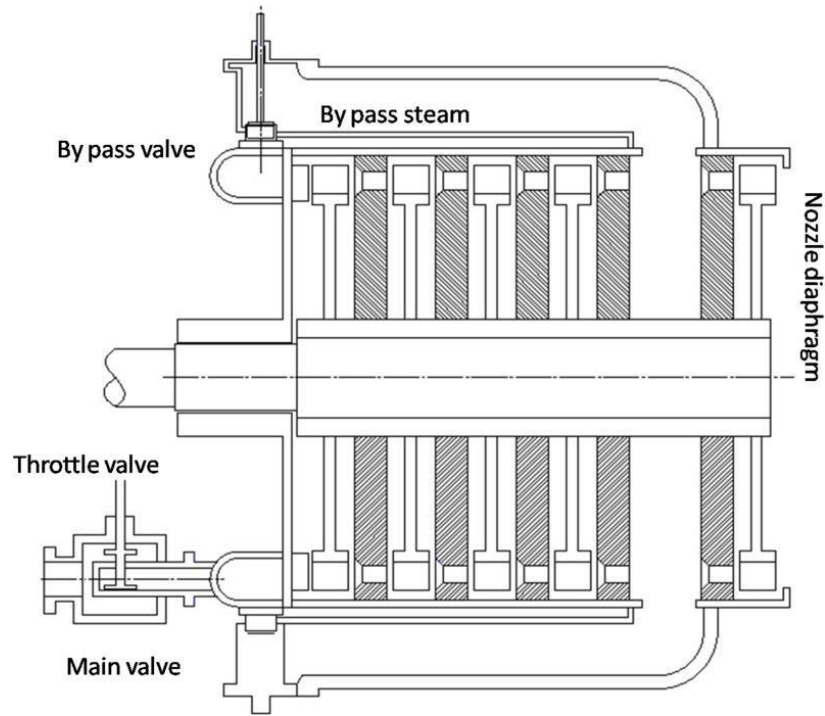

**Nozzle Control Governing:**

- It is basically used for part load condition.
- In this method, some set of nozzles are grouped together and steam flow to each group of the nozzle is controlled by valves. Actually, nozzle control governing is restricted to the first stage of turbine whereas the subsequent nozzle are in other stage remains constant.
- In this governing rate of steam flow is depending on the opening and closing of set of nozzles rather than regulating its pressure.

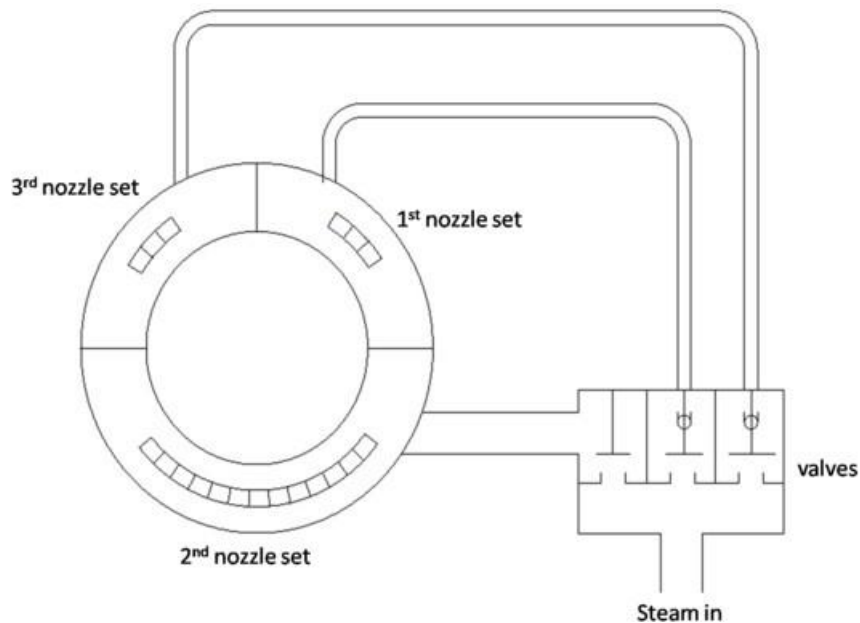

## Performance of steam turbine:

- **Blade efficiency or Diagram efficiency:**

It is the ratio of the work done on the blades per kg of steam to the energy supplied to the blades per kg of steam.

Mathematically: Blade efficiency ( $\eta_b$ ) = 
$$\frac{(V_{w1} + V_{w2}) \times V}{\frac{V_1^2}{2}} = \frac{(V_{w1} + V_{w2}) \times 2V}{V_1^2}$$

- **Stage efficiency:**

It is the ratio of the work done on the blade in heat unit to the total heat energy supplied per stage.

If  $\Delta H$  is the total heat energy drop in the nozzle ring, then the total energy supplied per stage is

$J \times \Delta H$ .

Mathematically: 
$$\eta_s = \frac{(V_{w1} + V_{w2})}{W \cdot J \cdot \Delta H} = \frac{(V_{w1} + V_{w2})}{J \cdot \Delta H} \times \left(\frac{V_b}{g}\right)$$

- **Nozzle efficiency:**

It is the ratio between actual heat drop of steam in the nozzle and adiabatic or isentropic heat drop of steam in the nozzle.

Mathematically: Nozzle efficiency ( $\eta_N$ ) = 
$$\frac{\Delta H_{act}}{\Delta H_{th}}$$

- **Relation between efficiencies:**

Stage efficiency ( $\eta_s$ ) = Blade efficiency ( $\eta_b$ )  $\times$  Nozzle efficiency ( $\eta_N$ )

## Steam Condenser:

- A steam condenser is a closed vessel into which the steam is exhausted, and condensed after doing work in the turbine. A steam condenser has the following two objectives.
- The main object of condenser is to maintain a low pressure (below atmospheric pressure) so as to draw the maximum possible energy from steam. So, the efficiency of plant can be increased.
- It is used to supply pure feed water to the hot well, from where it is pumped back to the boiler.

## Classification of Condensers:

The steam condensers may be broadly classified into the following types:

- Jet condensers or mixing type condensers
  - Parallel flow jet condenser
  - Counterflow or low-level jet condenser
  - Barometric or high-level jet condenser, and
  - Ejector condenser
- Surface condensers or non-mixing type condensers.
  - Downflow surface condenser
  - Central flow surface condenser
  - Regenerative surface condenser
  - Evaporative condenser.

## Elements of Steam Condensing Plant:

A steam condensing plant consists of the following elements.

- **Condenser**
  - A condenser is the heat exchanger in which heat exchange occurs between the hot exhaust steam of turbine and cold water. It works at a low pressure.
- **Air Extraction Pump**
  - It is used to maintain the vacuum pressure inside of the condenser.
- **Condensate Extraction Pump**
  - It is a low-pressure pump which is used to remove the condensed from the condenser and to supply it into the hot well.
- **Cooling Water Circulating Pump**
  - It is used to circulate the cooling water from cooling tower to condenser.
- **Hot Well**
  - It is a tank which stores the condensate which comes from the condenser.
- **Cooling Tower**
  - It is a heat exchanger in which hot water extracted from the condenser transfers heat to the cold atmospheric air and gets converted into cold water. This cold water is supplied into the condenser by cooling water pump to remove heat from steam. Some amount of water gets vaporized in the cooling tower.
- **Boiler Feed Pump**
  - It is a pump which is used to supply the water from hot well to the boiler.
- **Makeup Water Pump**
  - When there is deficiency of cooling water, makeup water needs to be added by the help of the makeup water pump to deliver freshwater from a sump to the condensing plant.

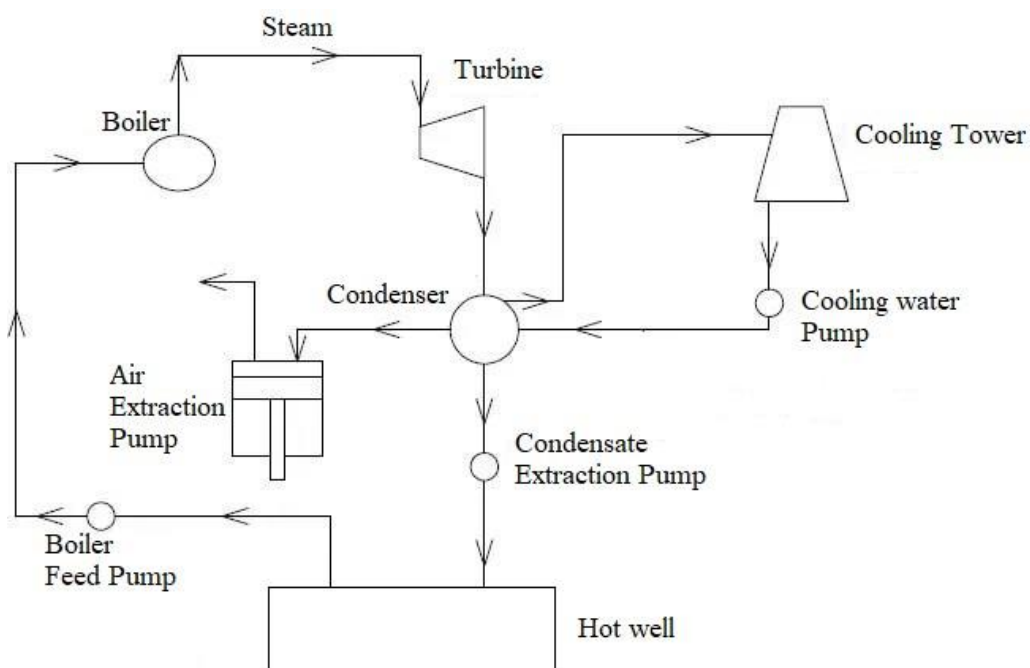

## Cooling Tower:

- Cooling tower is used to reject heat into the atmosphere.
- The cold water exits from the cooling tower is sent into the condenser. This water is converted into hot water after receiving heat from the steam inside the condenser. Hot water is extracted from the condenser and supplied to the cooling tower where it is cooled by the atmospheric air.

## Types of cooling tower:

Cooling towers can be classified on the basis of method of air circulation. Such as:

- Natural draught cooling tower
- Mechanical draught cooling tower
  - Forced draught cooling tower
  - Induced draught cooling tower

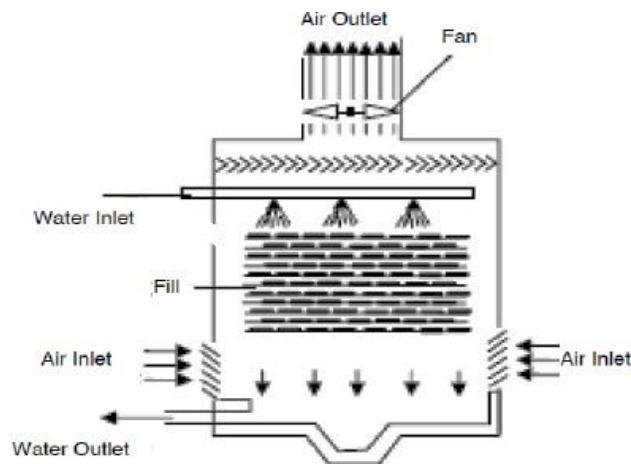

## Spray pond:

- A spray pond is a reservoir in which warmed water is cooled before reuse by spraying the warm water with nozzles into the cooler air.
- In spray type cooling method, a large surface of water is exposed for evaporation.
- The hot water extracted from the condenser is supplied to the surface of the cooling tank and is projected into thin horizontal sheets. Nozzles are fitted on the sheets. These nozzles break up the water into drops. Water droplets get cooled due to conduction and convection. Cold water is collected at the bottom of the tank.

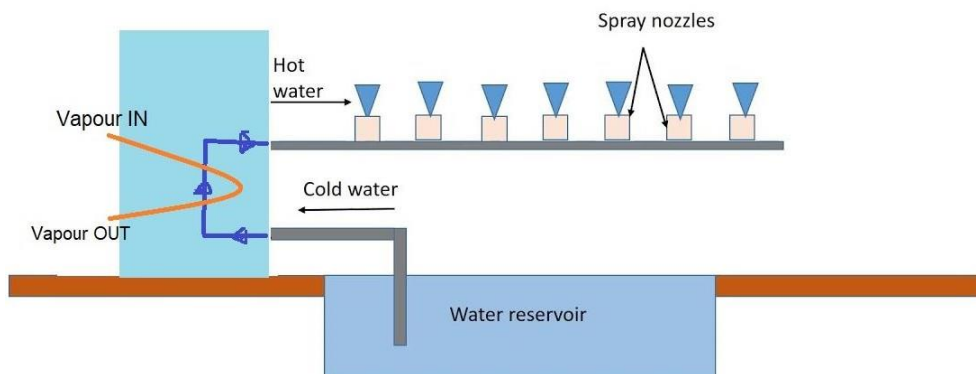

### List of thermal power plants in Odisha:

Sl.No.	Name of the Plant	Capacity in MW
1.	Jindal Steel and Power Ltd	810
2.	NALCO Ltd., Captive Power Plant	1200
3.	GMREnergy	1050
4.	Vedanta Ltd., IPP and CPP	2400 and 1215
5.	Talcher Super Thermal Power Station	3000
6.	Jindal India Thermal Power Ltd	1200
7.	Rourkela Steel Plant (CPP-I)	100
8.	Thermal Power Station (OPGC)	420
9.	HINDALCO Industries Ltd (CPP),	467
10.	TATA Bhushan Power & Steel Ltd.	370

### Site Selection for thermal power plants:

The following points should be taken into consideration while selecting the site for a steam power station.

- Availability of raw material
- Nature of land
- Cost of land
- Availability of water
- Transport facilities
- Ash disposal facilities
- Availability of labour
- Size of the plant
- Load centre
- Public problem
- Future extension

## CHAPTER -3 NUCLEAR POWER STATION

Classify nuclear fuel (Fissile & fertile material)

### Nuclear Reactions

#### Basics

- Atoms consist of nucleus and electrons.
- The nucleus is composed of protons and neutrons.
- Protons are positively charged whereas neutrons are electrically neutral.
- Atoms with nuclei having same number of protons but difference in their masses are called isotopes. They are identical in terms of their chemical properties but differ with respect to nuclear properties.
- Natural Uranium consists of  $^{92}\text{U}238$  (99.282%),  $^{92}\text{U}235$  (0.712%) and  $^{92}\text{U}234$
- $^{92}\text{U}235$  is used as fuel in nuclear power plants.

#### Energy from Nuclear Reactions

- The sum of masses of protons and neutrons exceeds the mass of the atomic nucleus and this difference is called mass defect  $\Delta m$ .
- In a nuclear reaction the mass defect is converted into energy known as binding energy
- According to Einstein's equation ( $E = \Delta m c^2$ ).
- Fashioning one amu of mass results in release of 931 MeV of energy.
- It has been found that element having higher and lower mass numbers are unstable. Thus the lower mass numbers can be fused or the higher mass numbers can be fissioned to produce more stable elements.
- This results in two types of nuclear reactions known as fusion and fission.
- The total energy per fission reaction of  $\text{U}235$  is about 200 MeV.
- Fuel burn-up rate is the amount of energy in MW/days produced by each metric ton of fuel.

**Fertile material** is a material that, although not itself fissionable by thermal neutrons, can be converted into a fissile material by neutron absorption and subsequent nuclei conversions.

### Naturally occurring fertile materials

---

Naturally occurring fertile materials that can be converted into a fissile material by irradiation in a reactor include:

- thorium-232 which converts into uranium-233
- uranium-234 which converts into uranium-235
- uranium-238 which converts into plutonium-239

Artificial isotopes formed in the reactor which can be converted into fissile material by one neutron capture include:

- plutonium-238 which converts into plutonium-239
- plutonium-240 which converts into plutonium-241
- 

In nuclear engineering, fissile material is material capable of sustaining a nuclear fission chain reaction. By definition, fissile material can sustain a chain reaction with neutrons of thermal energy. The predominant neutron energy may be typified by either slow neutrons (i.e., a thermal system) or fast neutrons. Fissile material can be used to fuel thermal-neutron reactors, fast-neutron reactors and nuclear explosives.

Fissile nuclides in nuclear fuels include:



- Uranium-235 which occurs in natural uranium and enriched uranium
- Plutonium-239 bred from uranium-238 by neutron capture
- Plutonium-240 bred from plutonium-239 by neutron capture.
- Plutonium-241 bred from plutonium-240 by neutron capture.
- Uranium-233 bred from thorium-232 by neutron capture

## Nuclear fusion

**Nuclear Fusion reactions** power the Sun and other stars. In a fusion reaction, two light nuclei merge to form a single heavier nucleus. The process releases energy because the total mass of the resulting single nucleus is less than the mass of the two original nuclei. The leftover mass becomes energy. Einstein's equation ( $E=mc^2$ ), which says in part that mass and energy can be converted into each other, explains why this process occurs.

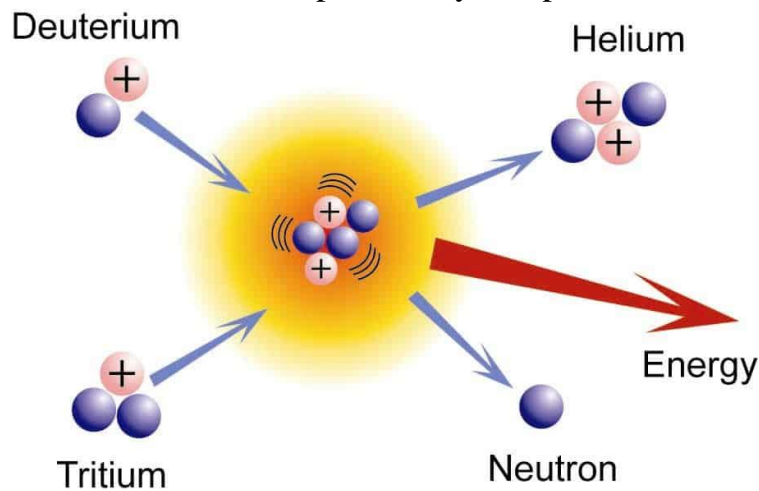

## Nuclear fission

Fission occurs when a neutron slams into a larger atom, forcing it to excite and split into two smaller atoms—also known as fission products. Additional neutrons are also released that can initiate a chain reaction.

When each atom splits, a tremendous amount of energy is released.

Uranium and plutonium are most commonly used for fission reactions in nuclear power reactors because they are easy to initiate and control.

The energy released by fission in these reactors heats water into steam. The steam is used to spin a turbine to produce carbon-free electricity.

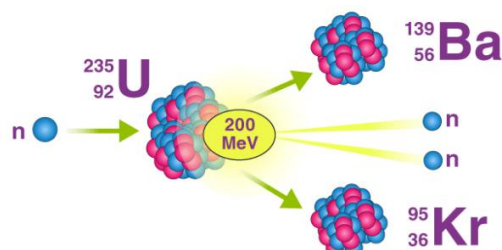

# WORKING OF NUCLEAR POWER PLANTS WITH BLOCK DIAGRAM

Nuclear power plants heat water to produce steam. The steam is used to spin large turbines that generate electricity. Nuclear power plants use heat produced during nuclear fission to heat water.

In nuclear fission, atoms are split apart to form smaller atoms, releasing energy. Fission takes place inside the reactor of a nuclear power plant. At the center of the reactor is the core, which contains uranium fuel.

The uranium fuel is formed into ceramic pellets. Each ceramic pellet produces about the same amount of energy as 150 gallons of oil. These energy-rich pellets are stacked end-to-end in 12-foot metal fuel rods. A bundle of fuel rods, some with hundreds of rods, is called a fuel assembly. A reactor core contains many fuel assemblies.

The heat produced during nuclear fission in the reactor core is used to boil water into steam, which turns the blades of a steam turbine. As the turbine blades turn, they drive generators that make electricity. Nuclear plants cool the steam back into water in a separate structure at the power plant called a cooling tower, or they use water from ponds, rivers, or the ocean. The cooled water is then reused to produce steam.

## COMPONENTS OF NUCLEAR POWER PLANT:

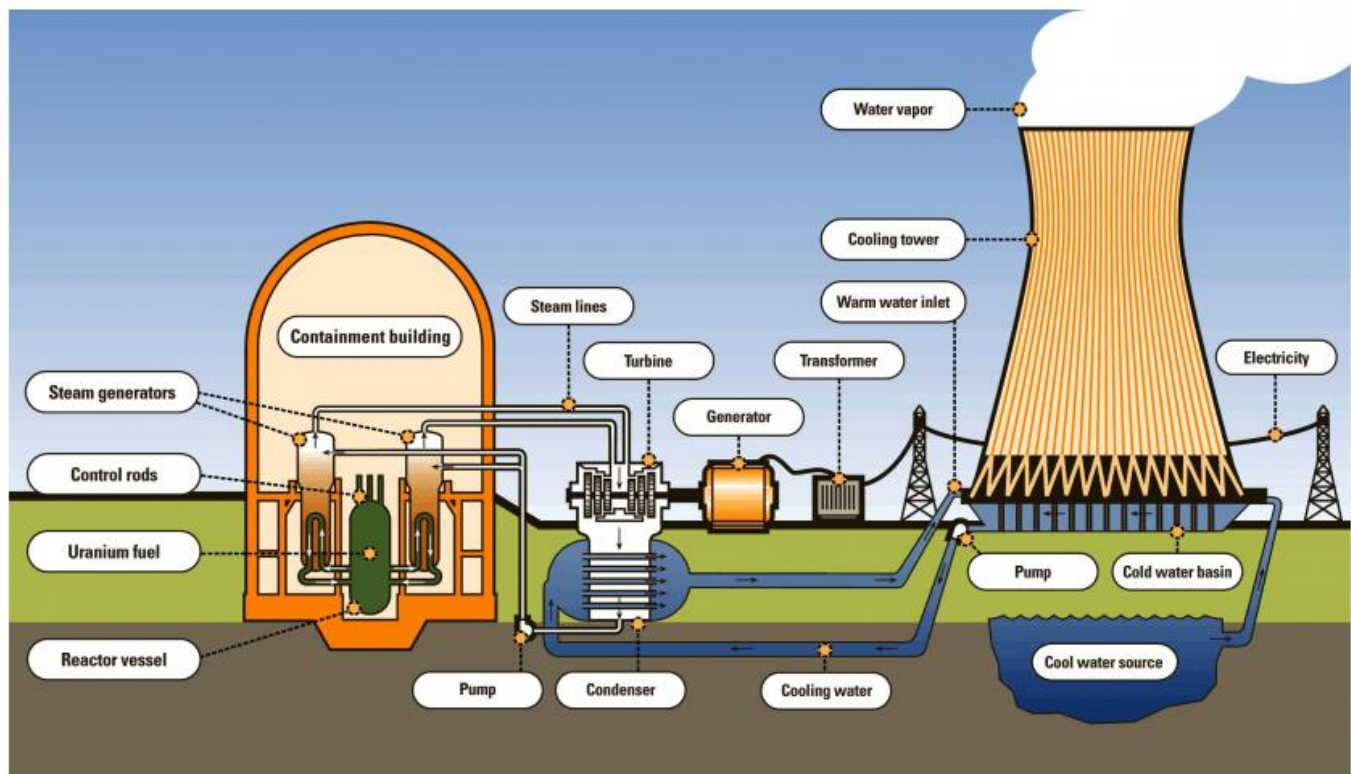

*Components of a nuclear power plant*

### **Pressurizer -**

A component of the primary cooling circuit where the liquid and vapor stages are balanced in conditions of saturation, so as to control the pressure.

### **Reactor Vessel -**

Steel vessel that houses the nuclear reactor, the main component of the nuclear power plant where the fission chain reaction is produced. Its nucleus is composed of the fuel elements.

### **Fuel -**

The material where the fission reactions take place. The most common material used is enriched uranium oxide. It is used simultaneously as a source of energy and neutrons in order to maintain the chain reaction. It is presented in solid state, in the form of cylindrical pellets encapsulated into metallic rods around 4 meters tall.

#### **Control Rod -**

These are the reactor's control elements, acting as neutron absorbents. They are made up of indium-cadmium or boron carbide, which make it possible to control at all times the neutron population and the reactor reactivity, making it critical during its operation and subcritical during the stops.

#### **Vapour generators-**

Heat exchangers where the cooling water from the primary cycle, which circulates around the inside of the inverted U-shaped tubes, yields its energy to the secondary circuit water and turns it into water vapor.

#### **Containment building -**

A building that houses the reactor's cooling system as well as several auxiliary systems. It functions as shielding in normal operation and prevents the leakage of polluting products to the exterior. Along with other safeguarding systems, it has the functional responsibility to avoid the release of fission products into the atmosphere in case of accident.

#### **Turbine -**

A device that receives the water vapor from the vapor generators, whose energy is transformed via the paddles into mechanical rotation power. There are various sections for the expansion of the vapor. Its axis is solidly attached to the alternator axis.

#### **Alternator -**

A device that produces electricity by converting mechanical rotation energy from the turbine into medium-power and high-intensity energy.

#### **Transformer -**

A device that raises the tension of the electricity produced in the alternator, in order to minimize losses during its transport to the consumption points.

#### **Cooling water -**

Water taken from a river, reservoir or the sea and used to liquify the water vapor in the condensate. It can be directly returned to its origin (open cycle) or be reused via the cooling tower (closed cycle).

#### **Cooling Tower -**

A device that makes it possible to yield to the atmosphere, which acts as a cold focus, part of the residual heat produced during the electricity generation. It is used to cool the water that circulates inside the condensate and is part of the plant's auxiliary cooling circuit.

#### **Condensator -**

Heat exchanger composed by a set of tubes where cooling water circulates. The water vapor going inside the condensator from the turbine is liquified. This conversion produces a vacuum that improves the turbine's performance.

### **Main Components of a Nuclear Reactor:**

- The Core: It contains all the fuel and generates the heat required for energy production.
- The Coolant: It passes through the core, absorbing the heat and transferring into turbines
- The Turbine: Transfers energy into the mechanical form
- The Cooling Tower: It eliminates the excess heat that is not converted or transferred
- The Containment: The enveloping structure that separated the nuclear reactor from the surrounding environment.

### **Components of a nuclear reactor**

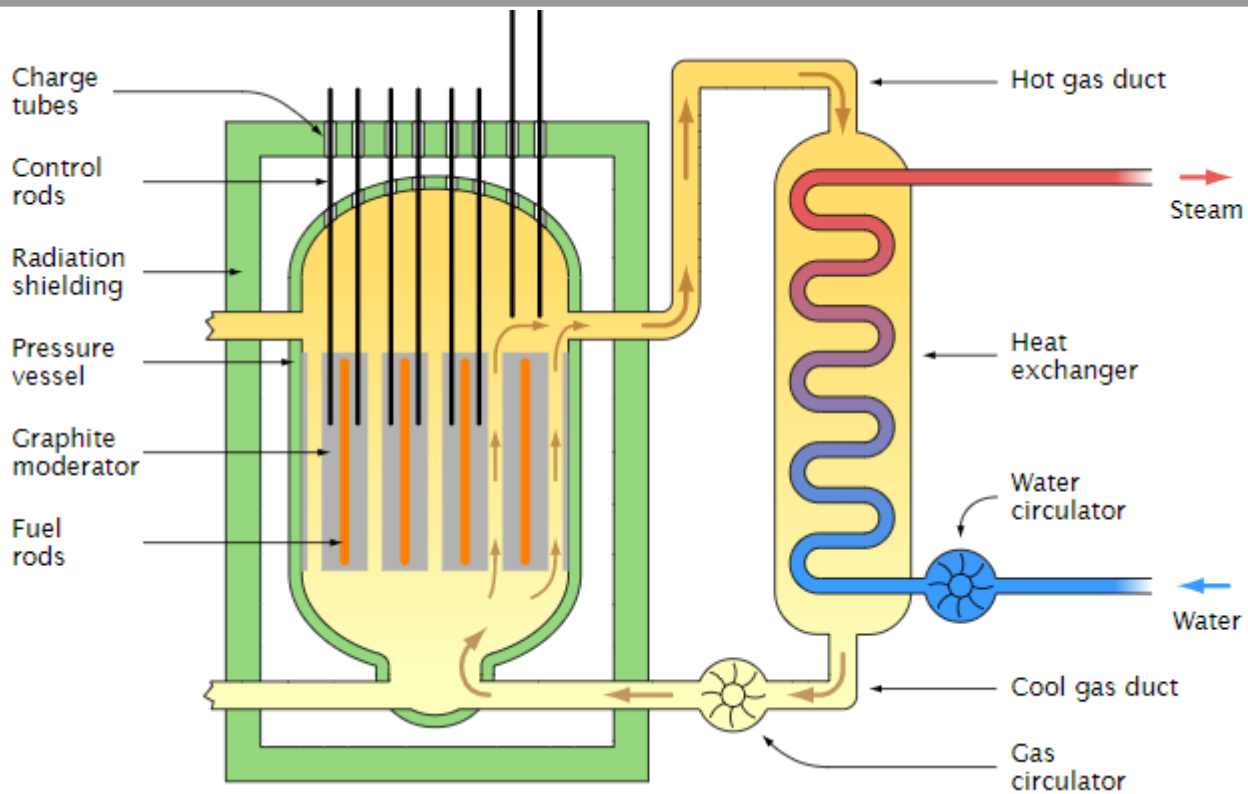

- Fuel. Uranium is the basic fuel.
- Moderator. Material in the core which slows down the neutrons released from fission so that they cause more fission.
- Control rods.
- Coolant.
- Pressure vessel or pressure tubes.
- Steam generator.
- Containment.
- Nuclear power plants in commercial operation or operable. Fuel Uranium is the basic fuel. Usually pellets of uranium oxide ( $UO_2$ ) are arranged in tubes to form fuel rods. The rods are arranged into fuel assemblies in the reactor core.\* In a 1000 MWe class PWR there might be 51,000 fuel rods with over 18 million pellets.

## Nuclear Fuels

Naturally occurring uranium is composed almost totally of two uranium isotopes. It contains more than 99% uranium-238 and less than 1% uranium-235. It is uranium-235. However, that is fissionable (will undergo fission). For uranium to be used as fuel in a fission reactor, the percentage of uranium-235 must be increased, usually to about 3%. (Uranium in which the U-235 content is more than 1% is called enriched uranium. The enriched  $UF_6$  gas is collected, cooled until it solidifies, and then taken to a fabrication facility where it is made into fuel assemblies. Each fuel assembly consists of fuel rods that contain many thimble-sized, ceramic-encased, enriched uranium (usually  $UO_2$ ) fuel pellets. Modern nuclear reactors may contain as many as 10 million fuel pellets. The amount of energy in each of these pellets is equal to that in almost a ton of coal or 150 gallons of oil. Once the supply of U-235 is acquired, it is placed in a series of long cylindrical tubes called fuel rods. These fuel cylinders are bundled together with control rods made of neutron-absorbing material. The amount of U-235 in all the fuel rods taken together is adequate to carry on a chain reaction but is less than the critical mass.

### Fuel Assembly



Spent fuel assemblies, are typically 14 feet (4.3 meters) long and contain nearly 200 fuel rods for PWRs and 80-100 fuel rods for BWRs.

## Nuclear Moderators

Neutrons produced by nuclear reactions move too fast to cause fission (Figure 7.4.47.4.4). For efficient collisions to occur, a moderator must be used to slow the speeds of the neutrons. Moderators can be composed of many different types of chemical substances. The first experimental nuclear reactors used high-purity graphite (or carbon) as a moderator. Today, many countries use light water (LW) as moderators. Otherwise known as H<sub>2</sub>O, this substance needs to in large supply. Most LW reactors are built near lakes or other freshwater sources. Depending on the type of fuel, a country would select a corresponding moderator for determining wattage output. Other types of moderators that are used today include heavy water (HW which is D<sub>2</sub>O), carbon dioxide, beryllium, or graphite.

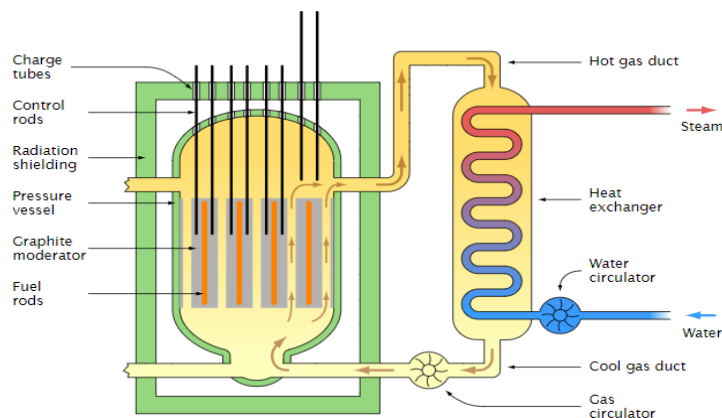

## Reactor Coolants

A nuclear reactor coolant is used to carry the heat produced by the fission reaction to an external boiler and turbine, where it is transformed into electricity. Two overlapping coolant loops are often used; this counteracts the transfer of radioactivity from the reactor to the primary coolant loop. All nuclear power plants in the US use light water as a coolant. Other coolants include molten sodium, lead, a lead-bismuth mixture, or molten salts.

## Control Rods

Nuclear reactors use control rods (Figure 7.4.57.4.5) to control the fission rate of the nuclear fuel by adjusting the number of slow neutrons present to keep the rate of the chain reaction at a safe level. Control rods are made of boron, cadmium, hafnium, or other elements that are able to absorb neutrons. Boron-10, for example, absorbs neutrons by a reaction that produces lithium-7 and alpha particles:

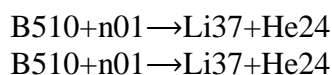

When control rod assemblies are inserted into the fuel element in the reactor core, they absorb a larger fraction of the slow neutrons, thereby slowing the rate of the fission reaction and decreasing the power

produced. Conversely, if the control rods are removed, fewer neutrons are absorbed, and the fission rate and energy production increase. In an emergency, the chain reaction can be shut down by fully inserting all of the control rods into the nuclear core between the fuel rods.

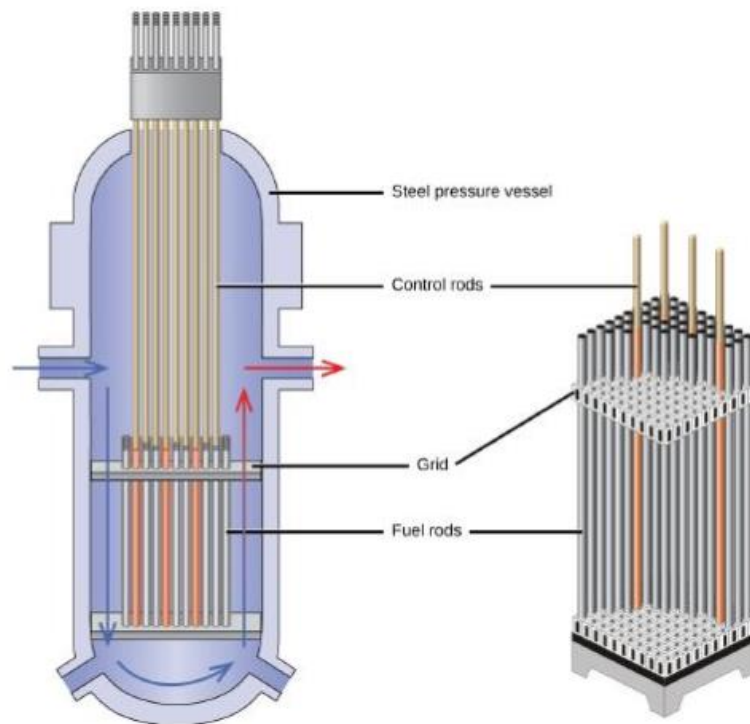

## Shield and Containment System

During its operation, a nuclear reactor produces neutrons and other types of radiation. Even when shut down, the decay products remain radioactive. In addition, an operating reactor is thermally very hot, and high pressures result from the circulation of water or another coolant through it. Thus, a reactor must withstand high temperatures and pressures and must protect operating personnel from the radiation.

Reactors are equipped with a containment system (or shield) that consists of three parts:

1. The reactor vessel, a steel shell that is 3–20-centimeters thick and, with the moderator, absorbs much of the radiation produced by the reactor
2. The main shield of 1–3 meters of high-density concrete
3. A personnel shield of lighter materials that protects operators from  $\gamma$  rays and X-rays

In addition, reactors are often covered with a steel or concrete dome that is designed to contain any radioactive materials that might be released by a reactor accident.

## Compare the nuclear and thermal plants:

Thermal Plant	Nuclear Plant
Located where water and coal and transportation facilities are adequate.	Located in isolated areas away from population.
Initial cost is lower than hydro and nuclear.	Initial cost is highest as cost of reactor construction is very high.
Running cost is higher than nuclear and hydro due to amount of coal required.	Cost of running is low as very very less amount of fuel is required.
Coal is source of power. So limited quantity is available.	Uranium is fuel source along with platinum rods. So sufficient quantity is available.
Cost of fuel transportation is maximum due to large demand for coal.	Cost of fuel transportation is minimum due to small quantity required.
Least environment friendly.	Better friend of environment than steam power plant.
25% overall efficiency.	More efficient than steam power.
Maintenance cost is very high.	Maintenance cost is the highest as highly skilled workers are required.
Maximum standby losses as boiler still keep running even though turbine is not.	Less standby losses.

## Disposal of nuclear waste:

- Radioactive wastes are stored so as to avoid any chance of radiation exposure to people, or any pollution.
- The radioactivity of the wastes decays with time, providing a strong incentive to store high-level waste for about 50 years before disposal.
- Disposal of low-level waste is straightforward and can be undertaken safely almost anywhere.
- Storage of used fuel is normally under water for at least five years and then often in dry storage.
- Deep geological disposal is widely agreed to be the best solution for final disposal of the most radioactive waste produced.

Most low-level radioactive waste (LLW) is typically sent to land-based disposal immediately following its packaging for long-term management. This means that for the majority (~90% by volume) of all of the waste types produced by nuclear technologies, a satisfactory disposal means has been developed and is being implemented around the world.

For used fuel designated as high-level radioactive waste (HLW), the first step is storage to allow decay of radioactivity and heat, making handling much safer. Storage of used fuel may be in ponds or dry casks, either at reactor sites or centrally. Beyond storage, many options have been investigated which seek to provide publicly acceptable, safe, and environmentally sound solutions to the final management of radioactive waste. The most widely favoured solution is deep geological disposal. The focus is on how and where to construct such facilities.

Used fuel that is not intended for direct disposal may instead be reprocessed in order to recycle the uranium and plutonium it contains. Some separated liquid HLW arises during reprocessing; this is vitrified in glass and stored pending final disposal.

Intermediate-level radioactive waste (ILW) that contains long-lived radioisotopes is also stored pending disposal in a geological repository. In the USA, defence-related transuranic (TRU) waste – which has similar levels of radioactivity to some ILW – is disposed of in the Waste Isolation Pilot Plant (WIPP) deep geological repository in New Mexico. A number of countries dispose of ILW containing short-lived radioisotopes in near-surface disposal facilities, as used for LLW disposal.

## **SELECTION OF SITE FOR NUCLEAR POWER PLANT:**

The various factors to be considered while selecting the site for nuclear plant are as follows:

1. Availability of water. At the power plant site an ample quantity of water should be available for condenser cooling and made up water required for steam generation. Therefore the site should be nearer to a river, reservoir or sea.
2. Distance from load centre. The plant should be located near the load centre. This will minimise the power losses in transmission lines.
3. Distance from populated area. The power plant should be located far away from populated area to avoid the radioactive hazard.
4. Accessibility to site. The power plant should have rail and road transportation facilities.
5. Waste disposal. The wastes of a nuclear power plant are radioactive and there should be sufficient space near the plant site for the disposal of wastes.

### **Nuclear Power Plants in India – Operational**

<b>Name Of Nuclear Power Station</b>	<b>Location</b>	<b>Operator</b>	<b>Capacity</b>
Kakrapar Atomic Power Station – 1993	Gujarat	NPCIL	440
(Kalpakkam) Madras Atomic Power Station – 1984	Tamil Nadu	NPCIL	440
Narora Atomic Power Station- 1991	Uttar Pradesh	NPCIL	440
Kaiga Nuclear Power Plant -2000	Karnataka	NPCIL	880
Rajasthan Atomic Power Station – 1973	Rajasthan	NPCIL	1,180
Tarapur Atomic Power Station – 1969	Maharashtra	NPCIL	1,400



### Introduction

This is a fossil fuel plant since diesel is a fossil fuel. Diesel engine powerplants are installed where supply of coal and water is not available in sufficient quantity.

- (i) These plants produce the power in the range of 2 to 50 MW.
- (ii) They are used as standby sets for continuity of supply such as hospitals, telephone exchanges, radio stations, cinema theatres and industries.
- (iii) They are suitable for mobile power generation and widely used in railways and ships.
- (iv) They are reliable compared to other plants.
- (v) Diesel power plants are becoming more popular because of difficulties experienced in construction of new hydel plants and thermal plants

### Layout of Diesel Power plant

The essential components of diesel power plant are

- Diesel engine
- Air filter and super charger
- Engine starting system
- Fuel system
- Lubrication system
- Cooling system
- Governing system
- Exhaust system

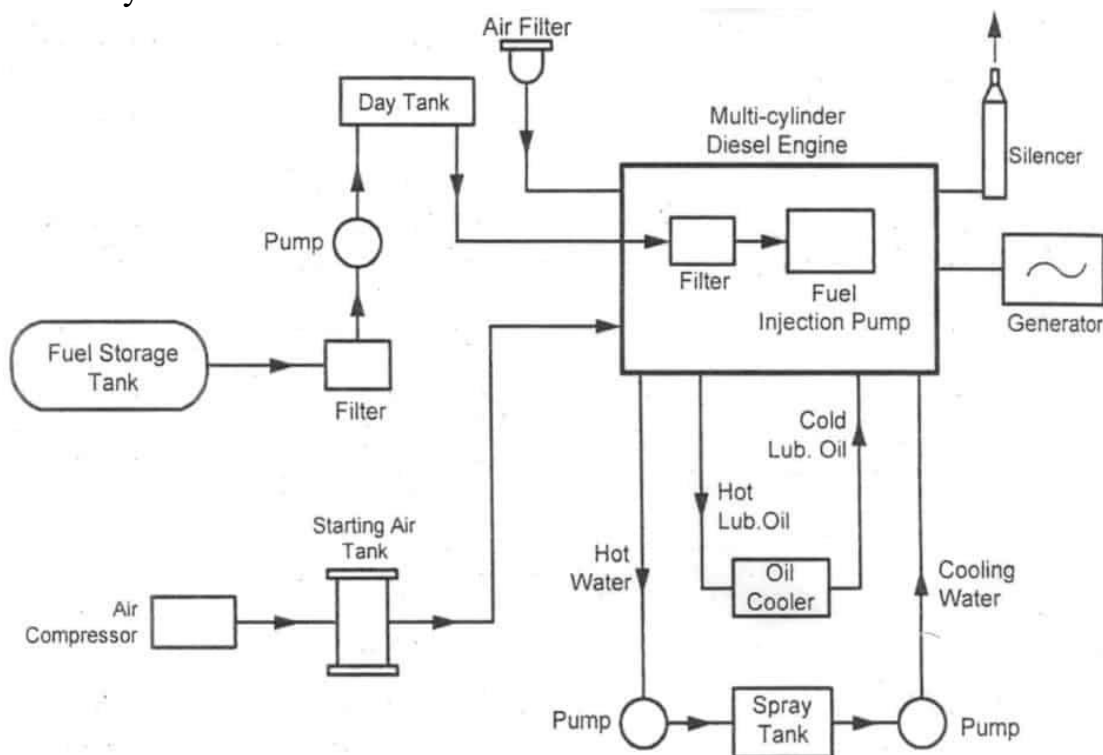

### Diesel power plant diagram

#### Diesel engine:

This is the main component of a diesel power plant. The engines are classified as two stroke engine and four stroke engines. Engines are generally directly coupled to the generator for developing power. In diesel engines, air admitted into the cylinder is compressed. At the end of compression stroke, fuel is injected. The

fuel is burned and the burning gases expand and do work on the piston. The shaft of the engine is directly coupled to the generator. After the combustion, the burned gases are exhausted to the atmosphere.

### **Air filter and supercharger**

The air filter is used to remove the dust from the air which is taken by the engine. Air filters may be of dry type, which is made up of felt, wool or cloth. In oil bath type of filters, the air is swept over a bath of oil so that dust particles get coated. The function of the supercharger is to increase the pressure of the air supplied to the engine and thereby the power of the engine is increased.

### **Engine starting system**

Diesel engine used in diesel power plants is not self starting. Engine starting system includes air compressor and starting air tank. This is used to start the engine in cold conditions by supplying the air.

### **Fuel system**

It includes the storage tank, fuel pump, fuel transfer pump, strainers and heaters. Pump draws diesel from the storage tank and supplies it to the small day tank through the filter. Day tank supplies the daily fuel need for the engine. The day tank is usually placed high so that diesel flows to engine under gravity. Diesel is again filtered before being injected into the engine by the fuel injection pump.

The fuel injection system performs the following functions.

- Filter the fuel
- Meter the correct quantity of the fuel to be injected
- Time the injection process
- Regulate the fuel supply
- Secure fine atomization of fuel oil
- Distribute the atomized fuel properly in the combustion; chamber.

The fuel is supplied to the engine according to the load on the plant.

### **Lubrication system**

It includes oil pumps, oil tanks, coolers and pipes. It is used to reduce the friction of moving parts and reduce wear and tear of the engine parts such as cylinder walls and piston. Lubrication oil which gets heated due to the friction of the moving parts is cooled before re-circulation.

In the lubrication system the oil is pumped from the lubricating oil tank through the oil cooler where the oil is cooled by the cold water entering the engine. The hot oil after cooling the moving parts return to the lubricating oil tank.

### **Cooling system**

The temperature of the burning fuel inside the engine cylinder is in the order of 1500 °C to 2000 °C. In order to lower this temperature, water is circulated around the engine. The water envelopes (water jacket) the engine, the heat from the cylinder, piston, combustion chamber etc, is carried by the circulating water. The hot water leaving the jacket is passed through the heat exchanger. The heat from the heat exchanger is carried away by the raw water circulated through the heat exchanger and is cooled in the cooling tower.

### **Governing system**

It is used to regulate the speed of the engine. This is done by varying the fuel supply according to the engine load.

### **Exhaust system**

The exhaust gases coming out of the engine is very noisy. In order to reduce the noise a silencer (muffler) is used.

## **Working of Diesel Power Plant**

The air and fuel mixture act as a working medium in diesel engine power plant. The atmosphere air enters inside the combustion chamber during the suction stroke and the fuel is injected through the injection pump. The air and fuel is mixed inside the engine and the charge is ignited due to high compression inside the engine cylinder. The basic principle in diesel engine is that, the thermal energy is converted into mechanical energy and this mechanical energy is converted into electrical energy to produce the power by using generator or alternator.

## **Applications of Diesel Engines in Power Field**

The diesel electric power plants are ch briefly used in the following field.

### **(a) Peak load plant:**

Diesel plants can be used in combination with thermal or hydro-plants as peak load units. They can be easily started or stopped at a short notice to meet the peak demand.

### **(b) Mobile plant:**

Diesel plants mounted on trailers can be used for temporary or emergency purposes such as for supplying power to large civil engineering works.

### **(c) Standby unit:**

If the main unit fails or cannot cope up with the demand, a diesel plant can supply the necessary power. For example, if water available in a hydro-plant is not adequately available due to less rainfall, the diesel station can operate in parallel to generate the short fall in power.

### **(d) Emergency plant:**

During power interruption in a vital unit like a key industrial plant or a hospital, a diesel electric plant can be used to generate the needed power.

### **(e) Nursery station:**

In the absence of main grid, a diesel plant can be installed to supply power in a small town. In course of time, when electricity from the main grid becomes available in the town, the diesel unit can be shifted to some other area which needs power on a small scale. Such a diesel plant is called a “nursery station”.

### **(f) Starting stations:**

Diesel units can be used to run the auxiliaries (like FD and ID fans, BFP, etc.) for starting a large steam power plant.

### **(g) Central stations :**

Diesel electric plants can be used as central station where the capacity required is small

## ***Advantages and disadvantages of diesel power plant***

Following are the advantages of diesel power plant

1. It is easy to design and install these electric stations.
2. They are easily available in standard capacities.
3. They can respond to lo ad change s without much difficulty.
4. There are less standby losses.
5. They occupy less space.
6. They can be started and stopped quickly.
7. They require less cooling water.
8. Capital cost is less.
9. Less operating and supervising g staff f required.
10. High efficiency of energy conversion from fuel to electricity.

11. Efficiency at part loads is also higher.
12. Less of civil engineering work is required.
13. They can be located near the load centre.
14. There is no ash handling problem.
15. Easier lubrication system.

## Disadvantages in installing diesel units for power generation

1. High operating cost.
2. High maintenance and lubrication cost.
3. Capacity is restricted. Cannot be of very big size.
4. Noise problem.
5. Cannot supply overload.
6. Unhygienic emissions.
7. The life of the diesel power plant is less (7 to 10 years) as compared to that of a steam power plant which has a life span of 25 to 45 years. The efficiency of the diesel plant decreases to less than 10% after its life period.

## Site selection of diesel power plant

The following Factors should be considered while selecting the site for a diesel power plant:

- **Foundation sub-soil condition:** the condition of sub-soil should be such that a foundation at a reasonable depth should be capable of providing a strong support to the engine.
- **Access to the site:** the site should be so selected that it is accessible through rail and road.
- **Distance from that load centre:** The location of the plant should be near the load centre. This reduces the cost of transmission lines and maintenance cost. The power loss is minimized.
- **Availability of water:** Sufficient quantity of water should be available at the site selected.
- **Fuel transportation:** The site selected should be near to the source of fuel supply so that transportation charges are low.
- **Bearing capacity:** The diesel engine is placed on a foundation. If the bearing capacity of selected land is high then it does not require high depth for a foundation. And it will save the initial cost of a power plant.
- **Transportation facility:** The plant requires heavy pieces of machinery. Hence, the selected site must have an adequate transportation facility.
- **Labor:** Large capacity diesel power plant requires several labors.
- **Availability of water:** The diesel power plant requires water for cooling purposes.
- **Future expansion:** There is some extra land available for future expansion.
- **Availability of fuel:** This plant requires a high volume of fuel (diesel). So, a site should be selected where fuel is available easily.
- **Distance from the populated area:** The operation of a diesel engine pollutes nearby areas. Hence, the plant must be located at a far distance from the human being.
- **Distance from load center:** To avoid transmission loss, the site should be selected near the load center.

## Performance of Diesel Engine:

### Performance parameters

#### The Diesel Engine

The prime mover for diesel power plants is the diesel engine running on IDO or HFO. Kipevu 1 engines are started on Industrial diesel oil (IDO) but change over to heavy fuel oil (HFO) before full load and vice versa.

#### Engine Performance Criteria

Performance of an engine is determined by a number of indicators or criteria, namely indicated power, fuel power, brake power, brake thermal efficiency and indicated thermal efficiency, specific fuel consumption among others.

#### Brake Power

$$BP = \frac{2\pi NT}{60}$$

Where: T is the torque in Newton-meter (N-m)  
 N is the angular velocity in revolutions per minute (rpm)

### Indicated Power

This is the power developed by combustion of fuel in the engine cylinder. It is given by;  $IP = PVNK/60$

Where: P is the mean pressure  
 V is the displacement volume of the piston  
 K is the number of cylinder

### Friction Power

This refers to the difference between indicated power and brake power. It represents all the losses of the engine mainly due to friction, leakages and incomplete combustion.  
 $FP = IP - BP$

### Mechanical Efficiency

It is given as the ratio of brake power to indicated power as a percentage.  $\eta_M = Bp/Ip * 100\%$

### Indicated Thermal Efficiency

This is the rate of indicated power to thermal input.

$$\eta_i = Ip / \text{fuel power}$$

Fuel power =  $m_f * C_v$  where  $m_f$  is mass flow rate and  $C_v$  is lower calorific value

## 4.2.8 Brake thermal efficiency ( $\eta_{Bn}$ )

This is the ratio of brake output to thermal input.  $\eta_{Bp} = Bp / m_f * C_v$

### Specific Fuel Consumption

It is a measure of the fuel used to generate a kWh of power. It is given by the ratio of brake power to the product of mass flow rate and volume flow rate.

$$Sfc = Bp / m_f * Q_{net}$$

### Thermal Efficiency for Diesel Cycle

A typical **diesel automotive engine** operates at around **30% to 35%** of thermal efficiency. **Low-speed diesel engines** (as used in ships) can have a thermal efficiency that exceeds **50%**.

Thermal efficiency for Diesel cycle:

$$\eta_{Diesel} = 1 - \frac{1}{CR^{\kappa-1}} \left( \frac{\alpha^{\kappa} - 1}{\kappa(\alpha - 1)} \right)$$

where

- $\eta_{Diesel}$  is the maximum thermal efficiency of a Diesel cycle
- $\alpha$  is the **cut-off ratio**  $V_3/V_2$  (i.e., the ratio of volumes at the end and start of the combustion phase)
- $CR$  is the **compression ratio**
- $\kappa = c_p/c_v = 1.4$

A power plant that utilizes the potential energy of water for the generation of electrical energy is known as a hydroelectric power plant.

Hydroelectric power plants are generally located in hilly areas where dams can be built easily, and large water reservoirs can be made. In a hydropower plant, a water head is created by building a dam across a river or lake. From the dam, water is fed to a water turbine.

### Working Principle of Hydroelectric Power Plant

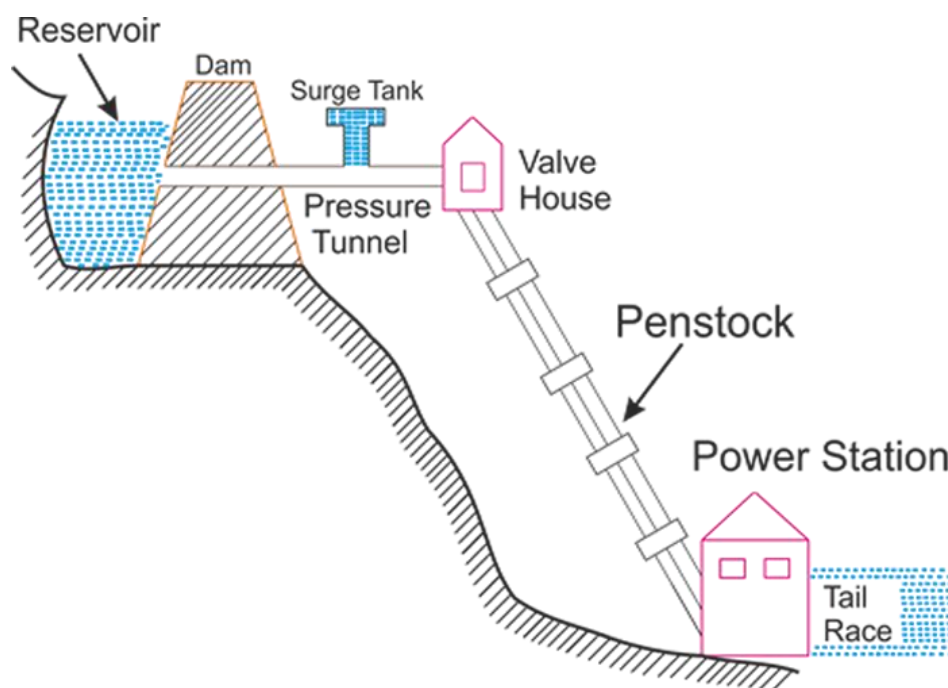

### LAYOUT OF HYDRO ELECTRIC POWER PLANT

The water turbine changes the kinetic energy of the falling water into mechanical energy at the turbine shaft. In simple words, falling water spins the water turbine. The turbine drives the alternator coupled with it and converts mechanical energy into electrical energy. This is the basic “working principle of hydroelectric power plant.”

Hydroelectric power plants are very popular because the stores of fuels (i.e., oil and coal) are exhausting day by day. They are also beneficial for irrigation and flood control purposes.

Basically, a modern hydropower plant is comprised of a reservoir, a dam, penstocks, turbines, and generators. The reservoir stores the “fuel” and allow operators to control how much water is fed to the turbines. It also serves as a decanter: Most of the dirt and debris in the water settle at its bottom and away from the intake area.

Water from the reservoir is delivered to the turbines through the intake (dam gates) and penstock. A filtering system at the intake further cleans up the water to ensure that it is relatively free of suspended solids, which could damage the turbine’s blades. Hydraulic systems – the governor, the brakes, the gate

controls, and so on – work together to open and close the apertures that allow water to flow downstream from the reservoir.

The water wheel of the past has evolved into the modern turbine. Differing mainly in their blade shape and configuration, the three main types are the Francis turbine, the Kaplan turbine, and the Pelton turbine – named after their inventors. Regardless of design, the turbine converts the kinetic energy of moving or falling water into mechanical energy. The turbine is connected through the shaft to the rotor of a generator that converts the mechanical energy into electricity. For the greatest efficiency, turbines are custom-made for each hydroelectric plant.

### Elements of Hydroelectric Power Plant

The main elements of a hydroelectric power plant are as follows:

**Catchment area:** The total area behind the dam in which water is collected and streamflow is obtained is known as the catchment area.

**Reservoir:** It is an integral part of the power plant, where water is stored and supplied to a water turbine continuously.

**Dam:** A dam is a barrier that stores water and creates a water head.

**Slip-way:** Due to heavy rainfall in the catchment area, the water level may exceed the storage capacity of the reservoir. It may affect the stability of the reservoir.

A structure is formed around the reservoir to remove this excess water. This structure is known as slip-way. Slip-way provides stability to the reservoir and reduces the level of water in the time of the flood.

**Surge Tank:** It is a small tank (open at the top). It is provided to reduce the pressure surges in the conduit. It is located near the beginning of the conduit.

**Penstocks:** Penstocks are open or closed conduits that carry water to the turbines. They are generally made of RCC or steel. The RCC penstocks are suitable for low water heads (< 30 m). The steel penstocks are ideal for any head, as they can be designed according to water head or working pressure.

**Water turbines:** It works as an energy conversion device. It is a machine through which the potential energy of water is converted into the mechanical energy of shaft. The main types of water turbines are:

(i) Impulse turbines (ii) Reaction turbines

**Impulse turbines:** Such turbines are used for high water heads. It consists of a wheel fitted with elliptical buckets along its periphery. The whole pressure of water is converted into kinetic energy in a nozzle, and the velocity of the jet spins the wheel — for example, the Pelton wheel turbine.

**Reaction turbines:** The important types of reaction turbines are:

(a) Francis turbines (b) Kaplan turbines

A Francis turbine is used for low to medium heads. A Kaplan turbine is used for low heads and large quantities of water.

### Water Turbine Generators:

They are low RPM (75 to 300) synchronous generators with main **exciters** usually mounted at the top on the shaft end. The machines are generally air-cooled with closed-circuit cooling.

**Power House Auxiliaries:** The hydroelectric power plant requires the same basic auxiliaries as any other power plant such as the governor system, exciters, cranes, control panels, etc. Power supply for the auxiliaries, cranes, and lighting is usually arranged from a small independent hydraulic turbine and generator.

### Hydroelectric Power Plant Advantages

- More reliable power plant.
- Low operating cost.
- Low starting time.
- High production rate capacity.
- The fuel cost is zero.
- Pollution-free.
- Renewable source of energy.
- Life of the power plant is more.
- They are also used for flood control and irrigation.

### **Hydroelectric Power Plant Disadvantages**

- Capital cost is high.
- Output depends upon the availability of water.
- Commonly found in hill-areas.
- Apparatus needs corrosion protection.

The hydroelectric power plants may be classified according to:- A. Classification According to the Extent of Water Flow Regulation Available B. Classification According to Availability of Water Head

### **Applications of Hydroelectric Power Plant:**

The applications of Hydroelectric Power Plant are as follows.

- The water which stays in a reservoir can be used for agriculture purposes.
- Thermal Power stations can be built near the reservoirs.
- It is used for the generation of electric power.
- It will control the floods in the rivers.
- The micro hydropower plant is used to provide power to isolated rooms.

*A. Classification According to the Extent of Water Flow Regulation Available:*

**According to the extent of water flow regulation available the hydroelectric power plants may be classified into:**

- (1) Run-off river power plants without pondage.
- (2) Run-off river power plants with pondage.
- (3) Reservoir power plants.

#### **1. Run-Off Power Plants without Pondage:**

Some hydro power plants are so located that the water is taken from the river directly, and no pondage or storage is possible. Such plants are called the run-off river power plants without pondage. Such plants can use water only as and when available; these cannot be used at any time at will or fit any desired portion of the load curve. In such plants there is no control on flow of water.

During high flow and low load periods, water is wasted and during the lean flow periods the plant capacity is very low. As such these plants have a very little firm capacity. At such places, the water is mainly used



for irrigation or navigation and power generation is only incidental. Such plants can be built at a considerably low cost but the head available and the amount of power generated are usually very low.

During floods, the tail water level may become excessive rendering the plant inoperative. The main objective of such plants is to use whatever flow is available for generation of energy and thus save coal that otherwise be necessary for the steam plants. During the high flow periods such plants can be employed to supply a substantial portion of base load.

## **2. Run-Off River Power Plants with Pondage:**

The usefulness of run-off river power plants is increased by pondage. Pondage refers to storage at the plant which makes it possible to cope, hour to hour, with fluctuations of load throughout a week or some longer period depending on the size of pondage. With enough pondage, the firm capacity of the power plant is increased.

Such type of power plants can be used on parts of the load curve as required, within certain limitations and is more useful than a plant without pondage. Such power plants are comparatively more reliable and its generating capacity is less dependent on available rate of flow of water. Such power plants can serve as base load or peak load power plants depending on the flow of stream.

During high flow periods these plants may be used as base load and during lean flow periods these plants may be used to supply peak loads only. When providing pondage, tailrace condition should be such that floods do not raise the tailrace water level, thus reducing the head on the plant and impairing its effectiveness. Such plants offer maximum conservation of coal when operated in conjunction with steam power plants.

## **3. Reservoir Power Plants:**

When water is stored in a big reservoir behind a dam, it is possible to control the flow of water and use it most effectively. Storage increases the firm capacity of the plant and it can be used efficiently throughout the year. Such a plant can be used as a base load or as a peak load plant as per requirement. It can also be used on any portion of the load curve in a grid system. Most of the hydroelectric power plants everywhere in the world are of this type.

### *B. Classification According to Availability of Water Head:*

**According to availability of water head the hydroelectric power plants may be classified into:**

(a) Low Head

(b) Medium Head and

(c) High Head Power Plants.

Though there is no definite line of demarcation for low, medium and high heads but the head below 30 metres is considered low head, the head above 30 metres and below 300 metres is considered as medium head and above 300 metres is considered as high head.

### **(b) Medium Head Hydroelectric Power Plants:**

In these power plants, the river water is usually tapped off to a forebay on one bank of the river as in case of a low head plant. From the forebay the water is led to the turbines through penstocks. The forebay provided at the beginning of penstock serves as a water reservoir for such power plants.

In these plants, water is usually carried in open channel from main reservoir to the forebay and then to the turbines through the penstock. The forebay itself serves as the surge tank in this case. In these plants horizontal shaft Francis, propeller or Kaplan turbines are used.

### **(c) High Head Hydroelectric Power Plants:**

If high head is available, a site may be chosen, where a stream descending a steep lateral valley can be dammed and a reservoir for storage of water is formed. A pressure tunnel is constructed between reservoirs to valve house at the start of penstock to carry water from reservoir to valve house.

Surge tank (a tank open from the top) is built just before the valve house so that the severity of water hammer effect on penstock can be reduced in case of sudden closing of fixed gates of the water turbine. Surge tank also serves as a ready reservoir from which the turbine can draw water temporarily when there is sudden increase in demand.

The valve house consists of main sluice valves and automatic isolating valves, which operate on bursting of penstock and cut off further supply of water to penstock. Penstocks are pipes and carry the water from the valve house to the turbines.

For heads above 500 m Pelton wheels are used while for lower heads Francis turbines are employed. The generators used are of high speed and small diameter. Penstocks are of large length and comparatively smaller cross section.

### *C. Classification According to Type of Load Supplied:*

**According to the load supplied hydroelectric power stations may be classified into:**

- (a) Base Load,
- (b) Peak Load, and
- (c) Pumped Storage Plants for the Peak Load.

#### **(a) Base Load Plants:**

The plants, which can take up load on the base portion of the load curve of the power system, are called the base load power plants. Such plants are usually of large capacity. Since such plants are kept running practically on block load (i.e., the load that is practically constant), load factor of such plants is therefore high. Run-off river plants without pondage and reservoir plants are used as base load plants.

Plants having large storage can best be used as base load plants and particularly in rainy seasons, when the water level of the reservoir will be raised by rain water. For a plant to be used as base load plant, the unit cost of energy generated by the plant should be low.

#### **(b) Peak Load Plants:**

Plants used to supply the peak load of the system corresponding to the load at the top portion of the load curve are called the peak load plants. Runoff river plants with pondage can be employed as peak load plants. If the pondage is enough, a large portion of the load can be supplied by such a plant if and when required. Reservoir plants can of course be used as peak load plants also. Peak load plants have large seasonal storage. They store water during off-peak periods and are operated during peak load periods. Load factor of such plants is low.

Following factors must be consider while selecting the site of the hydro generating station.

### **Site selection of Hydropower plant**

- The quantity of water available
- Storage of water
- Head of water
- The distance of power station site from load centers
- Accessibility of the site
- Water pollution
- Geological investigation
- Environmental effect

#### *1) The quantity of water available*

On the basis of measurements of stream flow, the quantity of water is estimated. In this estimation, also consider the previous record of rainfall, the maximum and minimum quantity of water available throughout the year and losses due to evaporation and percolation. Therefore, the net volume of water available for power generation can be determined.

#### *2) Storage of water*

The storage capacity of water can be calculate from the mass curve. During the year, wide variation in rainfall occurs. Hence, It makes necessary to store water for continuous generation of power throughout the year.

#### *3) Head of water*

The water head depends on the topology of the area. The head of water has a considerable effect on the cost and economy of power generation. Low falls on the unregulated flow of water are uneconomical for power generation. So, it is necessary to choose a site with a high head of water.

#### 4) *The distance of power station site from load centers*

If the load center is far from the power station, it will increase the cost of the transmission line. The losses occur in the transmission line increase the cost. Therefore, the site for hydropower plant choose near the load center.

#### 5) *Accessibility of the site*

The site is easily accessible by rail and by road. So, it is easy for the transportation.

#### 6) *Water pollution*

Polluted water may damage the blade of the turbine by corrosion. Hence, this led to the unreliable operation of the plant. Therefore, it is necessary that the quality of water is good.

#### 7) *Geological investigation*

It is necessary to choose a place which can withstand the water thrust and other stress. The construction of the plant is strong and stable. This construction can withstand natural calamities like thunderstorm, earthquake, etc.

#### 8) *Environmental effect*

The place chooses that is free from hazards and chemical effects.

So, these are the factors which must be consider while selecting the site of hydropower plant.

### **Types of Water Turbine**

In a hydroelectric power plant, a device which is used to convert the energy of falling water into mechanical energy is known as *water turbine*. There are two types of water turbines used in a hydroelectric power plant viz. –

- Impulse Turbine
- Reaction Turbine

#### **Impulse Turbine**

In an impulse turbine, the entire pressure of water is converted into kinetic energy in a nozzle and the velocity of the water jet drives the turbine wheel. Impulse turbines are used for high heads. The *pelton wheel* is an example of the impulse turbine. It consists of a wheel fitted with elliptical buckets along its periphery. The force of water jet striking the buckets on the wheel drives the turbine. The quantity of water jet falling on the turbine is controlled by a needle placed in the tip of the nozzle and the movement of the needle is controlled by the governor.

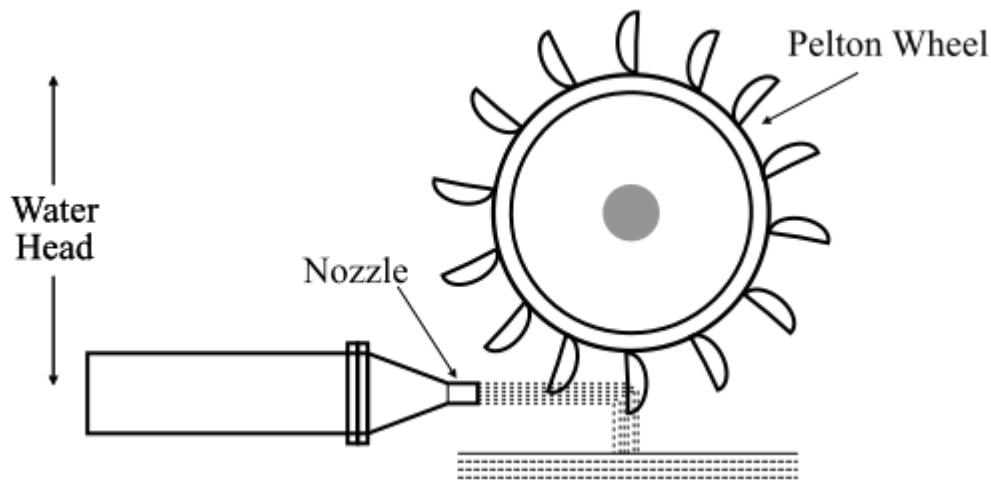

When the load on the turbine decreases, the governor pushes the needle into the nozzle and hence decreasing the quantity of water striking the buckets. On the other hand, when the load is increased, the governor pulled out the needle from the nozzle, thereby increasing the quantity of water striking the buckets.

### Reaction Turbine

In a reaction turbine, water enters the runner partly with velocity head and partly with pressure energy. Reaction water turbines are mainly used for medium and low heads.

Reaction turbines are also classified into two types viz. –

- Francis Turbine
- Kaplan Turbine

#### Francis Turbine

The Francis turbine is used for low to medium water heads. The Francis turbine consists of an outer ring of stationary guide blades which are fixed to the turbine casing and an inner ring of moving blades forming the runner. The guide blades are used to control the flow of water to the turbine.

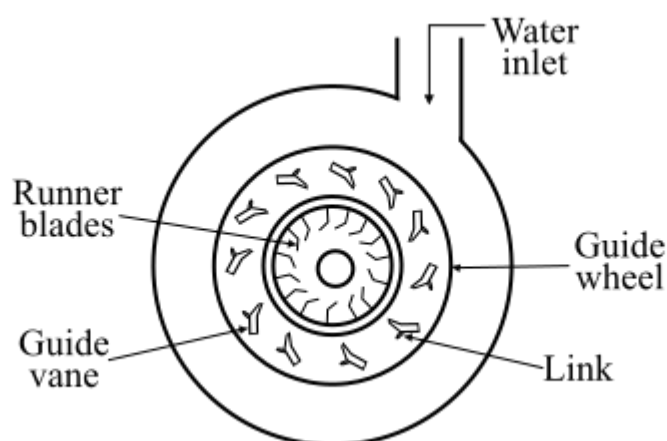

In the Francis turbine, the water flows radially inwards and changes to a downward direction while passing through the runner. When water passes over the rotating blades of the runner, both the velocity and pressure of water are reduced. Consequently, a reaction force is produced which drives the turbine.

#### Kaplan Turbine

A Kaplan turbine is used for low heads and large quantity of water. The runner of the Kaplan turbine receives water axially instead of radially.

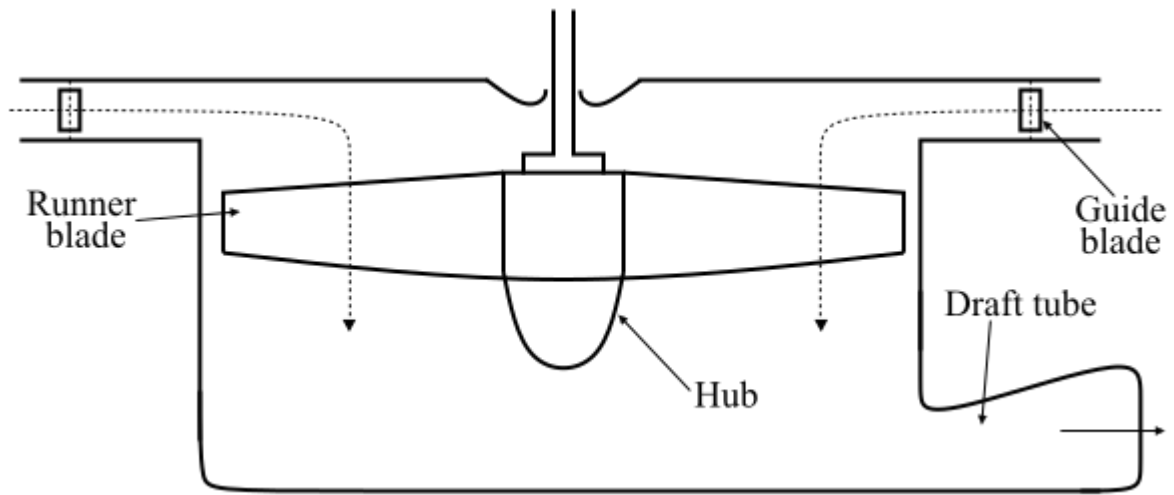

In a Kaplan turbine, water flows radially inwards through the regulating gates all around the sides and then, changing the direction in the runner to axial flow. Consequently, a reaction force is produced which drives the turbine.

**List of hydel power plants in state**

Power Stations	Installed Capacity (MW)
Rengali	5 x 50 MW
Upper Kolab	4 x 80 MW
Upper Indravati	4 x 150 MW
Machkund	60 MW

In all power generating stations except solar power generating station employ alternator to generate electrical energy. An alternator is a rotating machine which can produce electricity only when it rotates. Hence there must be a prime mover which helps to turn the alternator. The primary arrangement of all power plants is to rotate the prime mover so that alternator can generate required electricity. In gas turbine power plant we use high pressure and temperature air instead of high pressure and temperature steam to rotate the turbine.

The fundamental working principle of a gas turbine power plant is same as that of a steam turbine power plant. The only difference is there that in steam turbine power plant we use compressed steam to rotate the turbine, but in gas turbine power plant we use compressed air to turn the turbine.

In the gas turbine power plant air is compressed in a compressor. This compressed air then passes through a combustion chamber where the temperature of the compressed air rises. That high temperature and high-pressure air is passed through a gas turbine. In turbine the compressed air is suddenly expanded; hence it gains kinetic energy, and because of this kinetic energy the air can do mechanical work for rotating the turbine.

In a gas turbine power plant, the shaft of turbine, alternator and air compressor are common. The mechanical energy created in the turbine is partly utilised to compress the air. Gas turbine power plants are mainly used as standby auxiliary power supplier in a hydroelectric power plant. It generates auxiliary power during starting of a hydroelectric power plant.

#### **Advantages of Gas Turbine Power Plant**

- Construction wise a gas turbine power plant is much simpler than a steam turbine power plant.
- The size of a gas turbine power plant is smaller than that of a steam turbine power plant.
- A gas turbine power plant does not have any boiler like component, and hence, the accessories associated with the boiler are absent here.
- It does not deal with steam hence it does not require any condenser hence no cooling tower like structure is needed here.
- As design and construction wise gas turbine power plants are much more straightforward and smaller, the capital cost and running cost are quite less than that of an equivalent steam turbine power plant.
- The constant loss is quite smaller in gas turbine power plant compared to a steam turbine power plant because in the steam turbine power plant boiler has to run continuously even when the system does not supply load to the grid.
- A gas turbine power plant can more instantly be started than an equivalent steam turbine power plant.

#### **Disadvantages of Gas Turbine Power Plant**

- The mechanical energy created in the turbine is also utilized to run the air compressor. Since a major portion of mechanical energy created in the turbine is utilized to run the air compressor the overall efficiency of gas turbine power plant is not as high as an equivalent steam turbine power plant.
- Not only have that, the exhaust gases in gas turbine power plant carries significant heat from the furnace. This also causes the efficiency of the system low further.
- To start power plant pre-compressed air is required. So before actual starting of the turbine air should be pre-compressed which requires an auxiliary power supply for starting a gas turbine power plant. Once the plant is started there is no more need of supplying external power but at starting point external power is essential.
- The temperature of the furnace is quite high in a gas turbine power plant. This makes the system lifespan smaller than that of an equivalent steam turbine power plant.
- Because of its lower efficiency, a gas turbine power plant cannot be utilized for commercial production of electricity instead it is normally used to supply auxiliary power to other conventional power plants such as hydroelectric power plant.

#### Site selection for Gas Turbine power plant

- **Availability of fuels:** The fuels should be easily available at reasonably cheaper rates.
- **Transportation:** Transportation facility be available.
- **Distance from the load center:** To minimize losses and transmission line cost, the station shall be located near load center.
- **Availability of good quality land:** Land must be capable of withstanding station load vibrations transmitted to foundations. It should be cheaper in cost to have low capital cost.
- **Pollution:** The station is polluted by gas outlets, noise, so the station should be away from populated area.

#### Gas turbine Fuels

Various fuels used by gas turbine power plants are liquid fuels and gaseous fuels such as natural gas, blast furnace gas, producer gas coal gas and solid fuels such as pulverized coal. Care should be taken that the oil fuel should not contain moisture and suspended impurities.

The different types of oils used may distilled oils and residual oils. The various paraffins used in gas turbine are methane, ethane, propane, octane (gasoline) and dodecane (kerosene oil). Out of these gasoline and kerosene or blend of the two are commonly used.

#### Classification of Gas Turbine:

A gas turbine can be operated on either closed cycle or open cycle principle.

##### i. Closed Cycle Gas Turbine:

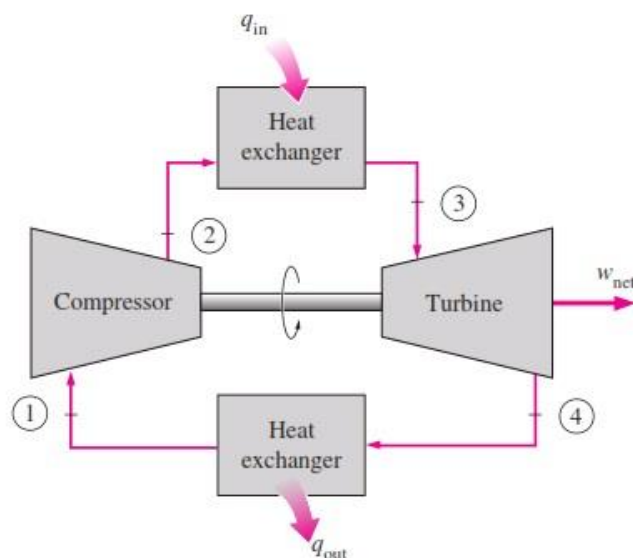

In case of a closed cycle gas turbine, a fixed mass of working substance is allowed to flow inside the cycle. The working substance, i.e., air or gases, is confined inside the plant and it never leaves the plant.



Hence, the gas turbine is said to be a closed cycle. Figure below shows the system diagram of a simple closed cycle gas turbine plant. It consists of a compressor, heater, gas turbine, and a cooler. The compressor shaft and turbine shaft are coupled for the transfer of power. The working substance is compressed by the compressor.

The high-pressure and high-temperature gas coming out from the compressor is heated by an external source of heat which further increases the temperature of the gas. The gas is then supplied to the gas turbine where the expansion of gas takes place up to a lower pressure. The flow of gas takes place through the blade passage where kinetic energy is absorbed.

Thus, the rotation of the shaft is obtained and power is developed at the turbine shaft. The low-pressure gas is then exhausted from turbine and enters into the cooler where cooling of the gas is done by circulating coolant. The cooled gas at low temperature and pressure again enters into the compressor and the process is repeated over and over again.

### **Advantages of Closed Gas Turbine Power Plant**

Following are the advantages of a closed gas turbine:

1. No contamination.
2. Higher thermal efficiency.
3. Improved load part efficiency.
4. No loss of working medium.
5. Expensive fuel
6. Reduced size.
7. Improved heat transmission.
8. Less fluid friction.
9. Greater output.

### **Disadvantages of Closed Gas Turbine Power Plant:**

*Following are the disadvantages of closed gas turbine:*

1. Complicated in design.
2. The high initial cost of the plant.
3. It requires a high quantity of cooling water.
4. Poor response to the load variations.
5. It requires a very big heat exchanger.

### **ii. Open Cycle Gas Turbine:**

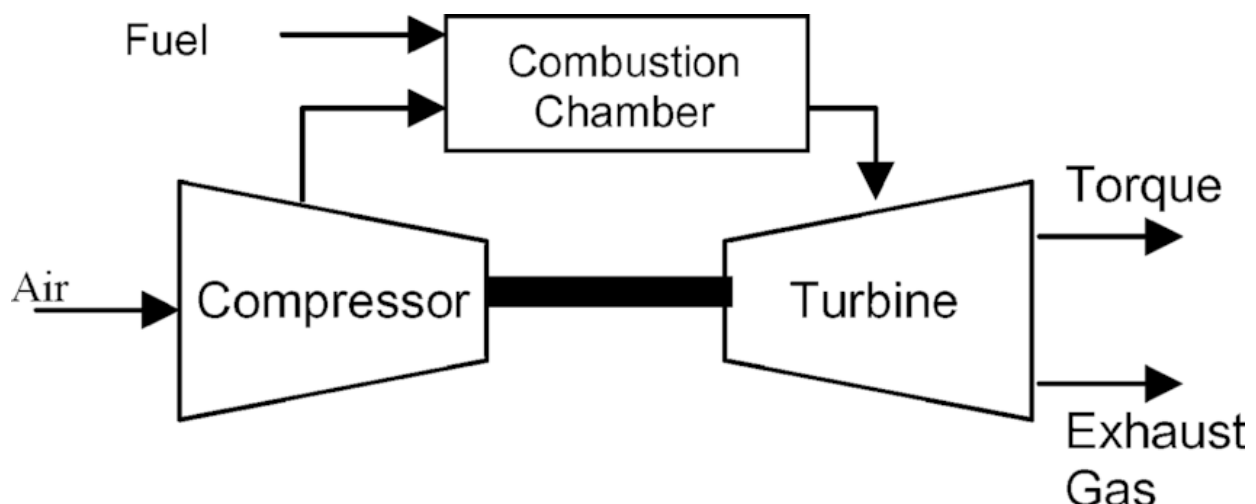

A simple open cycle gas turbine plant consists of an air compressor, combustion chamber, and a gas turbine.

Initially, the plant is started with the help of an auxiliary engine or electric motor. Atmospheric air is drawn in the compressor and compressed to a high pressure, and relatively high temperature, and is then supplied to a combustion chamber or combustor in which liquid or gaseous fuel is injected into the compressed air stream and the fuel is ignited.

The resulting high-pressure and high-temperature product of combustion is then passed to the turbine and is expanded to a lower pressure and finally discharged to the atmosphere through exhaust pipe.

The shaft starts rotating by the flow of gas. The turbine shaft is directly coupled with compressor and excess power is produced by the turbine which is used for the purpose of operating auxiliaries. Again fresh air is sucked into the compressor and thus the cycle is repeated. In almost all the fields, open cycle gas turbine plants are used.

#### **Advantages of Open Cycle Gas Turbine Power Plant-**

1. Once the turbine started, it will accelerate from cold start to full load without warm-up time.
2. Low weight and size.
3. It occupies relatively less space.
4. Almost any hydrocarbon fuel from high octane gasoline to heavy diesel oils can be used in the combustion chamber.
5. It does not require cooling water except for those having an intercooler.
6. Through auxiliary refinements, we can improve thermal efficiency and give the most economic overall cost for the plant load factors.

#### **Working of Gas Turbine Power Plant**

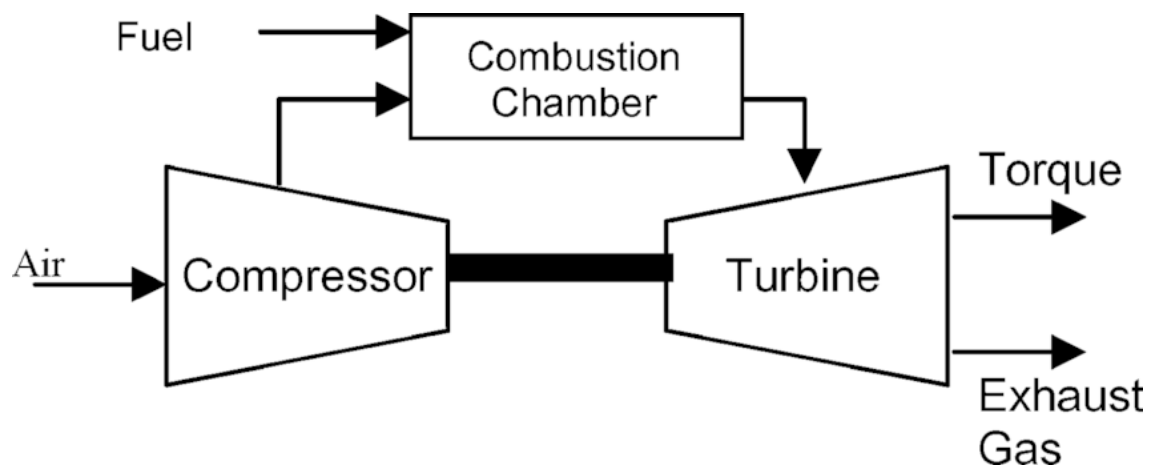

A schematic diagram of a gas turbine power plant is shown in the figure. It consists of a compressor, turbine, and combustion chamber.

Atmospheric air is drawn into the compressor and compressed to high pressure. The compressed air is supplied to the combustion chamber where heat is added to the air by burning the fuel and raising its temperature. The hot gas coming out from the combustion chamber is then passed to the turbine where it expands doing mechanical work.

Part of the power developed by the turbine is used to drive the compressor and other auxiliary equipment, and the remaining is used for power generation. The gas coming out of the turbine is exhausted into the atmosphere. This cycle is known as an open cycle power plant.

If the gas coming out from the turbine is cooled to its original temperature in a cooler and then it is recirculated to the compressor for doing work, such a cycle is known as a closed-cycle power plant.

## **Elements or Components of Gas Turbine Power Plant**

Following are the components of a gas turbine power plant:

1. Compressor
  2. Combustion chamber
    1. Can-type Combustor with Swirl Flow Flame Stabilizer
    2. Can-type Combustion with Bluff-body Flame Stabilizer
  3. Vertex blading
  4. Turbine
- 1. Compressor**

The compressor is used to compress the air to higher pressure. The type of compressors that are commonly used is centrifugal and axial flow types. The centrifugal compressor consists of an impeller and a diffuser.

The impeller provides high kinetic energy to the air and the diffuser converts kinetic energy into pressure energy. A centrifugal compressor consists of an impeller with a series of curved radial vanes as shown in the figure. Air is sucked in near the hub, called the impeller eye, and is whirled round at high speed by the vanes on the impeller rotating at high rpm. The axial flow compressor contains a series of rotors and stators. The air flows along the axis of the rotor. The kinetic energy is given to the air as it passes through the rotor and part of it is converted into pressure

### **2. Combustion Chamber**

In an open cycle, GT plant combustion may be arranged to take place in one or two large cylinder can-type combustion chambers (CC) with ducting to convey to the turbine. Combustion is begun by an electric spark and once the fuel starts burning the flame is need to stabilize.

### **3. Gas Turbines**

Like steam turbines, gas turbines are also of the axial flow type as shown in the figure. The primary requirements of turbines are high efficiency, light weight, reliability in operation, and long working life.

Large work output is obtained per stage with higher blade speeds when the blades are designed to maintain higher stresses. More stages are always preferred in gas turbine power plants because it helps to reduce the stresses in the blades and increases the overall life of the turbine.

Cooling of gas turbine blades is necessary for a long life as it is subjected to high-temperature gases. Blade angles of gas turbines follow the axial flow compressor blades, where the degree of reaction is not 50%.

It is usually assumed for any stage that the absolute velocity at the inlet to each stage ( $V_2$ ) is equal to the absolute velocity at the exit from the moving blades (ie.  $V_2$ ) and that the same flow velocity  $V_f$  is constant throughout the turbine.

The degree of reaction  $R$ , as determined for a steam turbine, is true for gas turbines also. It is the ratio of the enthalpy drop in the moving blades to the enthalpy drop in the stage.

## **Applications of Gas Turbine Power Plant**

The gas turbine plants are used for the following purposes:

1. It is used to drive the generators and supply peak loads in steam, diesel, or hydro plants.
2. To work as combustion plants with a conventional steam boiler.
3. To supply mechanical drive for auxiliaries.
4. Used in ships and jet aircraft.