

Indian Electricity Rules

24.1. INTRODUCTION

Before actually studying Indian Electricity Rules (I.E. Rules) and other precautions, we should discuss, why these rules and regulations have been framed.

The rules and regulations have been framed by Institution of Electrical Engineers to

- (i) safeguard consumers (users) of electrical energy from shock,
- (ii) minimise fire risk and
- (iii) ensure, as far as possible, satisfactory operation of equipment and apparatus used.

24.2. DEFINITIONS

1. **Ampere** means a unit of electric current and is the unvarying electric current which when passed through a solution of nitrate of silver in water, in accordance with the specifications set out in Annexure I, deposits silver at the rate of 0.001118 of a gramme per sec ;
2. **Accessible** means within physical reach without the use of any appliance or special effort ;
3. **Apparatus** means electrical apparatus and includes, all machines, fittings, accessories and appliances in which conductors are used ;
4. **Bare** means not covered with insulating material ;
5. **Cable** means a length of insulated single conductor (solid or stranded) or of two or more such conductors, each provided with its own insulation, which are laid up together. Such insulated conductor or conductors may or may not be provided with and overall mechanical protective covering ;
6. **Flexible Cable** means a cable consisting of one or more cores each formed of a group of wires, the diameter and the physical properties of the wires and the insulating material being such to afford flexibility ;
7. **Circuit** means an arrangement of conductor or conductors for the purpose of conveying energy and forming a system or a branch of a system ;
8. **Circuit Breaker** means a device, capable of making and breaking the circuit under all conditions, and unless otherwise specified, so designed as to break the current automatically under abnormal conditions ;
9. **Concentric Cable** means a composite cable comprising an inner conductor which is insulated and one or more outer conductors which are insulated from one another and disposed over the insulation of and more or less around the inner conductor ;
10. **Conductor** means any wire, cable, bar, tube, rail or plate used for conducting energy and so arranged to be electrically connected to a system ;
11. **Conduit** means rigid or flexible metallic tubing or mechanically strong and fire resisting non-metallic tubing in which a cable or cables may be drawn for the purpose of affording it or them mechanical protection ;
12. **Covered with insulating Material** means adequately covered with insulating material of such quality and thickness as to prevent danger ;
13. **Cut-out** means any appliance for automatically interrupting the transmission of energy through any conductor when the current rises above a pre-determined amount, and shall also include fusible cut-out.

14. **Danger** means danger to health or danger to life or any part of body from shock, burn or other injury to persons, or property, or from fire or explosion, attendant upon the generation, transmission, transformation, conversion, distribution or use of energy ;
15. **Dead** means at or about earth potential and disconnected from any live system ;
provided that apparatus separated from a live conductor by a spark gap shall not be deemed to be "dead".
Note. The term 'dead' is used only with reference to current carrying parts when these parts are not alive.
16. **Earthed or Connected with Earth** means connected with the general mass of earth in such a manner as to ensure at all times an immediate discharge of energy without danger ;
17. **Earthing System** means an electrical system in which all conductors are earthed ;
18. **Electrician** means a person over 21 years of age who is competent for the purposes of the rule in which the term is used and who has been appointed in writing by the lessee, owner, agent or manager of installation ;
19. **Enclosed Substation** means any premises or enclosure or part thereof, being large enough to admit the entrance of a person after the apparatus therein is in position, containing apparatus for transforming or converting energy to or from a voltage at or above medium voltage (other than transforming or converting solely for the operation of switchgear or instruments) with or without any other apparatus for switching, controlling or otherwise regulating the energy, and includes the apparatus therein ;
20. **Enclosed Switch Station** means any premises or enclosure or part thereof, being large enough to admit the entrance of a person after the apparatus therein is in position, containing apparatus for switching, controlling or otherwise regulating energy at or above medium voltage but not for transforming or converting energy (other than for transforming or converting solely for the operation of switchgear or instruments) and includes the apparatus therein ;
21. **Gaurded** means covered, shielded fenced or otherwise protected by means of suitable casings, barriers, rails or metal screens to remove the possibility of dangerous contact or approach by persons or objects to a point of danger ;
22. **Inspector** means an Electrical Inspector appointed under section 36 ;
23. **Installation** means any composite electrical unit used for the purpose of generating, transforming, transmitting, converting, distributing or utilizing energy ;
24. **Lightning Arrestor** means a device which has the property of diverting to earth any electrical surge of excessively high amplitude applied to its terminals and is capable of interrupting follow current if present and restoring itself thereafter to its original operating conditions ;
25. **Live** means electrically charged ;
26. **Metallic Covering** means mechanically strong metal covering surrounding one or more conductors ;
27. **Neutral Conductor** means that conductor of a multi-wire system, the voltage of which is normally midway between the voltages of other conductors of the system ;
28. **Occupier** means the owner or person in occupation of the premises where energy is used or proposed to be used ;
29. **Ohm** means a unit of electrical resistance and is the resistance offered to an unvarying electrical current by a column of mercury at the temperature of melting ice 14.4521 grammes in mass of a uniform cross-sectional area and of length of 16.3 centimetres ;
The aforesaid unit is represented by the resistance between the terminals of the instrument marked "Government of India Ohm Standard Verified" to the passage of an electric current when the coil of wire, forming part of the aforesaid instrument and connected to the aforesaid terminals is in all parts at a temperature of 30°C.

30. **Open Sparking** means sparking which owing to the lack of adequate provisions for preventing the ignition of inflammable gas external to the apparatus would ignite such inflammable gas ;
31. **Overhead Line** means any electric supply line which is placed above ground and in the open space but excluding live rails of a traction system ;
32. **Portable** means so designed as to be capable of being moved while in operation ;
35. **Portable Hand Lamp** means a portable light fitting provided with suitable handle, guard and flexible cord connected to a plug ;
34. **Span** means the horizontal distance between two adjacent supporting points of an overhead conductor ;
35. **Street Box** means a totally enclosed structure either above or below ground containing apparatus for transforming, switching, controlling or otherwise regulating energy ;
36. **Supplier** means a licensee, a non-licensee or any other supplier of energy ;
37. **Switch** means a manually operated device for opening and closing or for changing the connections of a circuit ;
38. **Switch Gear** shall denote switches, breakers, cutouts and other apparatus used for operation, regulation and control of circuits ;
39. **System** means an electrical system in which all the conductors and apparatus are electrically connected to a common source of electric supply ;
40. **Transportable Apparatus** means apparatus which is operated in a fixed position but which is so designed as to be capable of being moved readily from one place to another ;
41. **Volt** means a unit of electro-motive force and is the electric pressure which, when steadily applied to a conductor, the resistance of which is one ohm will, produce a current of one ampere ;
42. **Voltage** means the difference of electrical potential measured in volts between any two conductors or between any part of either conductor and the earth as measured by a suitable voltmeter and is said to be ;
 - Low** where the voltage does not exceed 250 volts under normal conditions subject, however, to the percentage variations allowed by these rules ;
 - Medium** where the voltage does not exceed 650 volts under normal conditions subject, however, to the percentage variation allowed by these rules ;
 - High** where the voltage does not exceed 33,000 volts under normal conditions subject, however, to the percentage variation allowed by these rules ;
 - Extra High** where the voltage exceeds 33,000 volts under normal conditions subject, however, to the percentage variation allowed by these rules ;

GENERAL SAFETY PRECAUTIONS

Rule 29. Construction, Installation, Protection, operation and maintenance of electric supply lines and apparatus.

All electric supply lines and apparatus shall be sufficient in power and size and of sufficient mechanical strength for the work they may be required to do, and so far as is practicable, shall be constructed, installed, protected, worked and maintained in accordance with standards for the Indian Standards Institution so as to prevent danger.

30. Service lines and apparatus on consumer's premises.

(1) The supplier shall ensure that all electric supply lines, wires, fittings and apparatus belonging to him or under his control which are on a consumer's premises are in a safe condition and in all respects fit for supplying energy, and the supplier shall take due precautions to avoid danger arising on such premises from such supply lines, wires, fittings and apparatus.

(2) Service-line placed by the supplier on the premises of a consumer which are underground or which are accessible shall be so insulated and protected by the supplier as to be secured under all ordinary conditions against electrical, mechanical, chemical or other injury to the insulation.

(3) The consumer shall, also as far as circumstances permit, take precautions for the safe custody of the equipment on his premises belonging to the supplier.

(4) The consumer shall also ensure that the installation under his control is maintained in a safe condition.

31. Cut-out consumer's premises.

(1) The supplier shall provide a suitable cut-out in each conductor of every line other than an earthed or earthed neutral conductor or the earthed external conductor of a concentric cables within a consumer's premises in an accessible position. Such cut-out shall be contained within adequately enclosed fire-proof receptacle.

Where more than one consumer is supplied through a common service line, each such consumer shall be provided with an independent cut-out at the point of junction to the common service.

(2) The owner of every electric supply line, other than the earthed or neutral conductor of concentric cable, shall protect it by suitable cut out.

32. Identification of earthed and earthed neutral conductor and position of switches and cut-outs therein.

Where the conductors include an earthed conductor of a two-wire system or an earthed neutral conductor of a multi-wire system or a conductor which is to be connected thereto, the following conditions shall be complied with :

(1) An indication of a permanent nature shall be provided by the owner of the earthed or earthed neutral conductor, or the conductor which is to be connected thereto, to enable such conductor to be distinguished from any live conductor. Such indication shall be provided

- (a) Where the earthed or earthed neutral conductor is the property of the supplier, at or near the point of commencement of supply.
- (b) Where a conductor forming part of a consumer's system is to be connected to the supplier's earthed or earthed neutral conductor, at the point where such connection is to be made.
- (c) In all other cases, at a point corresponding to the point of commencement of supply or at such other point as may be approved by an Inspector.

(2) No cut-out, link or switch other than a linked switch arranged to operate simultaneously on the earthed or earthed neutral conductor and live conductors shall be inserted or remain inserted in any earthed or earthed neutral conductor in a two-wire system or in any earthed or earthed neutral conductor of a multi-wire system or in any conductor connected thereto with the following exceptions.

- (a) A link for testing purposes, or
- (b) A switch for use in controlling a generator or transformer.

33. Earthed terminal on consumer's Premises.

(1) The supplier shall provide and maintain on the consumer's premises for the consumer's use a suitable earthed terminal in an accessible position at or near the point of commencement of supply as defined under rule 58.

Provided that in the case of medium, high or extra high voltage installation the consumer shall, in addition to the aforementioned earthing arrangement provide his own earthing system with an independent electrode.

Provided further that the supplier may not provide any earthed terminal in the case of installations already connected to his system on or before the date to be specified by the state Government in this behalf if he is satisfied that the consumer's earthing arrangement is efficient.

(2) The consumer shall take all reasonable precautions to prevent mechanical damage to the earthed terminal and its lead belonging to the supplier.

(3) The supplier may recover from the consumer the cost of installation of such earthed terminal on the basis laid down in sub-rule (2) of rule 82.

34. Accessibility of bare conductor. Where bare conductors are used in a building the owner of such conductors shall :

- (a) ensure that they are inaccessible ;
- (b) provide in readily accessible position switches for rendering them dead whenever necessary ;
- (c) take such other safety measures as are considered necessary by the Inspector.

35. Caution Notices. The owner of every medium, high and extra voltage installation shall affix permanently in a conspicuous position a caution notice in Hindi and the local language of the district of a type approved by the Inspector on :

- (a) every motor, generator, transformer and other electrical plant and equipment together with apparatus used for controlling or regulating the same ;
- (b) all supports of high and extra high voltage overhead lines ;
- (c) luminous tube sign requiring high voltage supply X-ray and similar high-frequency installation ;

Provided that where it is not possible to affix such notices on any generator, motor, transformer or other apparatus, they shall be affixed be near as possible thereto ;

Provided further that where the generator, motor transformer or other apparatus is within an enclosure, one notice affixed to the said enclosure shall be sufficient for the purposes of this rule.

36. Handling of electric supply lines apparatus. Before any conductor or apparatus is handled, adequate precautions shall be taken by earthing or other suitable means, to discharge electrically such conductor or apparatus and any adjacent conductor or apparatus if there is danger therefrom, and to prevent any conductor or apparatus from being accidentally or inadvertently electrically charged when persons are working thereon,

Provided that the sub-rule shall not apply to the cleaning of commutator and slip-rings working at low or medium voltage.

(2) No person shall work on any live electric supply line or apparatus and no person shall assist such person on such work unless he is authorised in that behalf, and takes the safety measures approved by the Inspector.

(3) Every telecommunication line on supports carrying a high or extra-high voltage line shall for the purpose of working thereon, be deemed to be a high voltage line.

37. Supply of Vehicle Cranes etc. Every person owning a vehicle, travelling crane or the like to which energy is supplied from an external source shall ensure that it is efficiently controlled by a suitable switch enabling all voltage to be cut-off in one operation and where such vehicles, travelling crane or the line runs on metal rails the owner shall ensure that the rails are electrically continuous and earthed.

38. Cables for portable or transportable apparatus. (1) Flexible cables shall not be used for portable or transportable motors, generators, transformers, rectifiers, electric drills, electric sprays, welding sets or any other portable or transportable apparatus unless they are heavily insulated and adequately protected from mechanical injury.

(2) Where the protection is by means of metallic covering it shall be in metallic connection with the frame of any such apparatus and earth.

39. Cables Protected by Bituminous Materials

(1) Where the supplier or the owner has brought into use an electric supply line (other than an overhead line) which is not completely enclosed in a continuous metallic covering connected with earth, and is insulated or protected *in situ* by composition or material of a bituminous character :

(a) any pipe, conduit or the like into which such electric supply line may, have been drawn or placed

shall, unless other arrangements are approved by the Inspector, in any particular case, be effectively sealed at its point of entry into any street box so as to prevent any flow of gas to or from the street box, and

(b) Such electric supply line shall be periodically inspected and tested where accessible and result of each such inspection and test shall be duly recorded by the supplier or the owner.

(2) It shall not be permissible for the supplier or the owner after the coming into force of these rules, to bring into use any further electric supply line as aforesaid which is insulated or protected *in situ* by any composition or material known to be liable to produce noxious explosive gases on excessive heating.

40. Street Boxes. (1) Street boxes shall not contain gaspipes, and precautions shall be taken to prevent, as far as reasonably possibly, say influx of water or gas.

(2) Where electric supply lines forming part of different systems pass through the same street box they shall be readily distinguishable from one another and all electric supply lines at high or extra-high voltage in street boxes shall be adequately supported so as to prevent risk of damage to or danger from adjacent electric supply lines.

(3) All street boxes shall be regularly inspected for the purpose of detecting the presence of gas and if any influx or accumulation is discovered, the owner shall give immediate notice to any authority or company who have gas mains in the neighbourhood of the street box and in cases where a street box is a large enough to admit the entrance of a person after the electric supply lines apparatus therein have been placed in position, ample provision shall be made.

(a) to ensure that any gas which may be accidentally have obtained access to the box shall escape before a person is allowed to enter, and

(b) for the prevention of danger from sparking.

(4) The owners of street boxes or pillars containing circuits or apparatus shall ensure that their covers and doors are so provided that they can be opened only by means of a key or a special appliance.

41. Distinction of circuit of different voltages. The owner of every generating station, sub-station, junction box or pillar in which there are many circuits or apparatus, intended for operation at different voltages, shall ensure by means of indication of a permanent nature that the respective circuits are readily distinguishable from one another.

42. Accidents Charge. The owner of all circuits and apparatus shall so arrange them that there shall be no danger of any part thereof becoming accidentally charged to any voltage beyond the limits of voltage for which they are intended.

Where A.C. and D.C. circuits are installed on the same supports they shall be so arranged and protected that they shall not come into contact with each other when live.

43. Provisions applicable to protective equipment. (1) Fire buckets filled with clean dry sand and ready for immediate use for extinguishing fires, in addition to fire extinguishers, suitable for dealing with electric fires, shall be conspicuously marked and kept in all generating stations, enclosed sub-stations and enclosed switch-stations in convenient situations.

(2) First aid boxes or cupboards, conspicuously marked and equipped with such contents as the State Government may specify, shall be provided and maintained in every generating station, enclosed sub-station and enclosed switch station so as to be readily accessible during all working hours. All such boxes and cupboards shall, except in the case of attended sub-stations and switch stations be kept in charge of responsible persons who are trained in first-aid treatment and one of such persons shall be available during working hours.

44. Instructions for Restoration of Persons suffering from Electric Shock : (1) Instructions, in English, Hindi and the local languages of the district for the restoration of person suffering from electric shock, shall be affixed by the owner in a conspicuous place in every generating station, enclosed sub-station, enclosed switch station and in every factory as defined in clause (m) of section 2 of the Factory Act, 1948

(LXIII of 1948) in which electricity is used and in such other premises where electricity is used as the Inspector may by notice in writing serve on the owner, direct.

(2) Copies of the instruction shall be supplied on demand by an officer appointed by the Central or State Government in this behalf at a price to be fixed by the Central or the State Government.

(3) The owner of every generating station, enclosed substation, enclosed switch station, and every factory or other premises to which this rule applies shall ensure that all authorised persons employed by him are acquainted with and are competent to apply the instructions referred to in sub-rule (1).

45. Precautions to be Adopted by Consumers, Owners, Electrical Contractors, Electrical Workmen and Suppliers : (1) No electrical installation work, including additions, alterations, repairs and adjustment to existing installations, except such replacement of lamps, fans, fuses, switches, low voltage domestic appliances and fitting as in no way alters its capacity of character, shall be carried out upon the premises of or on behalf of any consumer or owner, for the supply to such consumer or owner, except by an electrical contractor licensed in this behalf by the State Government and under the direct supervision of a person holding a certificate of competency issued or recognised by the State Government.

Provided that in the cases of works executed for or on behalf of the Central Government and in the cases of installations in mines, oil fields, and railways, the Central Government and in other cases the State Government may, by notification in the official Gazette, on such conditions as it may impose any such work described therein either generally or in the case of any specified class of consumers or owners, from so much of this sub-rule as requires such work to be carried out by an electrical contractor licensed by the State Government in this behalf.

(2) No electrical installation work which has been carried out in contravention of sub-rule (1) shall be connected with the works of any supplier.

(3) The provisions of sub-rule (1) shall come into force in respect of a state or part thereof on such date in the State Government may, by notification in the official Gazette appoint ;

Provided that the said provisions shall come into force in any oil field, mine or railways or in respect of any work carried out by, or on behalf of the Central Government only on such date as the Central Government may, by like notification, appoint.

46. Periodical inspection and testing of consumer's installation : (1) (a) Where an installation is already connected to the supply system of the supplier every such installation shall be periodically inspected and tested at intervals not exceeding five years either by the Inspector or by the supplier as may be directed by State Government in this behalf or in the case of installations in mines, oil-fields and railways, by the Central Government.

(b) Where the supplier is directed by the Central or the State Government, as the case may be, inspect and test the installation he shall report on the condition of the installation to the consumer concerned in a form approved by the Inspector and shall submit a copy of such report to the Inspector.

(2) (a) The fees for such inspection and test shall be determined by the Central or the State Government, as the case may be, in the case of such class of consumers and shall be payable by the consumers in advance.

(b) In the event of the failure of any consumer to pay the fees on or before the date specified in the fee-notice supply to the installation of such consumer shall be liable to be disconnected under the direction of the Inspector. Such disconnection, however, shall not be made by the supplier, without giving to the consumer seven clear days' notice in writing of his intention to do so.

(3) Notwithstanding the provisions of this rule, the consumer shall at all times be solely responsible for the maintenance of his installation in such conditions as to be free from danger.

GENERAL CONDITIONS RELATING TO SUPPLY AND USE OF ENERGY

47. Testing a consumer's installation : (1) Upon receipt of an application for a new or additional

supply of energy and before connecting the supply or reconnecting the same after a period of six months, the supplier shall inspect and test the applicant's installation.

The supplier shall maintain a record of test results, obtained at each supply point to a consumer, in a form to be approved by the inspector.

(2) If as a result of such inspection and test the supplier is satisfied that the installation is likely to constitute danger he shall serve on the applicant a notice in writing requiring him to make such modifications as are necessary to render the installation safe. The supplier may refuse to connect or reconnect the supply until the required modifications have been completed and he has been notified by the applicant.

48. Precautions against leakage before connecting : (1) The supplier shall not connect with his works the installation or apparatus on the premises of any applicant for supply unless he is reasonably satisfied that the connection will not at the time of making the connection cause a leakage from that installation or the apparatus exceeding one five-thousandth part of the maximum current supplied to the applicant's premises.

(2) If the supplier declines to make connection under the provisions of sub-rule (1) he shall serve upon the applicant a notice in writing, stating his reason for so declining.

49. Leakage on consumer's premises : (1) If the inspector or the supplier has reason to believe that there is in the system of consumer leakage which is likely to affect injuriously the use of energy by the supplier or by other persons, or which is likely to cause danger he may give the consumer reasonable notice in writing that he desires to inspect and test the consumer's installation.

(2) If no such notice being given :

- (a) the consumer does not give all reasonable facilities for inspection and testing of his installation, or
- (b) a leakage exceeding one five-thousandth part of the maximum current supplied to the consumer's installation is shown to exist.

The supplier may, and if directed to do so by the inspector, shall, discontinue the supply of energy to the installation but only after giving to the consumer forty-eight hour's notice in writing of disconnection of supply and shall not commence the supply until he or the Inspector is satisfied that the cause of the leakage has been removed.

50. Supply to consumers : (1) The supplier shall not commence or continue to give supply of energy to any consumer unless :

- (a) A suitable linked switch or a circuit-breaker of requisite capacity to carry and break the current is placed as near as possible to, but after the point of commencement of supply as defined under rule 58, so as to be readily accessible and capable of being easily operated to completely isolate the supply to the installation, such equipment being in addition to any equipment installed for controlling individual circuits or apparatus ;

Provided that where the point of commencement of supply and the consumer's apparatus are near each other, one linked switch or circuit-breaker near the point of commencement of supply shall be considered sufficient for the purpose of this rule ;

- (b) A suitable linked switch or a circuit breaker of requisite capacity to carry and break the full load current is inserted on the secondary side of a transformer, in the case of high or extra high voltage installation. Provided however, that the linked switch on the primary side of the transformer may be of such capacity as to carry the full load current and to break only the magnetising current of the transformer ;

Provided further that the provision of this clause shall not apply to transformers installed in sub-stations upto and including 100 kVA belonging to the supplier.

- (c) every distinct circuit is protected against excess energy by means of a suitable cut-out or a circuit breaker of adequate breaking capacity suitably located and so constructed as to prevent danger from over-heating, arcing or scattering of hot metal of the cut-out without danger ;

(d) the supply of energy to each motor or other apparatus is controlled by a suitable linked switch or a circuit breaker of requisite capacity placed in such a position as to be adjacent to the motor or other apparatus readily accessible to and easily operated by the person in charge and so connected in circuit that by its means all supply of energy can be cut off from the motor or apparatus and from regulating switch, resistance or other device associated therewith :

(e) all insulating material is chosen with special regard to the circumstances of its proposed use, the mechanical strength being sufficient for its purpose and so far as is practicable, is of such a character or so protected as to maintain adequately its insulating properties under all working conditions in respect of temperature and moisture ; and

(f) adequate precautions are taken to ensure that no live parts are so exposed as to cause danger.

(2) Every consumer or other user of energy shall so maintain his installation as to conform at all times to the provisions of sub-rule (1) and shall use all reasonable means in his power to ensure that where energy is supplied by a supplier, no person other than the supplier shall interfere with the service lines and apparatus placed by the supplier on his premises.

51. Provisions Applicable to Medium, High or Extra High voltage installations : The following provisions shall be observed where energy at medium, high or extra-high voltage is supplied, converted, transformed or used :

(1) (a) All conductors (other than those of overhead lines) shall be completely enclosed in mechanically strong metal casing or metallic covering which is electrically and mechanically continuous and adequately protected against mechanical damage unless the said conductors are accessible only to an authorised person or are installed and protected to the satisfaction of the Inspector so as to prevent danger.

(b) All metal work enclosing, supporting or associated with the installation other than that designed to serve as a conductor shall, if considered necessary by the Inspector be connected with earth.

(c) Every main switch-board shall comply with the following provisions, namely :

(i) a clear space of not less than 3 feet (91.44 cm) in width shall be provided in front of the switch board ;

(ii) if there are any attachment or bare connections at the back of the switch-board, the space (if any) behind the switch-board shall be either less than 9 inches (22.86 cm.) or more than 30 inches (76.2 cm.) in width measured from the farthest outstanding part of any attachment or conductor ;

(iii) if the space behind the switch board exceeds 30 inches (76.2 cm.) in width, there shall be a passage-way from either end of the switch board clear to a height of 6 feet (1.828 metres).

(2) Where an application has been made to a supplier for supply of energy to any installation, he shall not commence, or where the supply has been discontinued, recommence the supply unless he is satisfied that the consumer has complied in all respects with the conditions of supply set out in sub-rule (1) of this rule, rules 50 and 64.

(3) Where a supplier proposes to supply or use energy at medium voltage or to recommence supply after it has been discontinued for a period of six months he shall, before connecting or reconnecting the supply, give notice in writing of such intention to the inspector.

(4) If at any time after connecting the supply the supplier is satisfied that any provisions of sub-rule (1) of the rule, or of rules 50 and 64 is not being observed, he shall give notice of the same in writing to the consumer and the Inspector specifying how the provision has not been observed and may discontinue the supply if the Inspector so directs.

52. Appeal to Inspector in regard to defects : (1) If any applicant for supply or a consumer is

dissatisfied with the action of the supplier in deciding to commence, or to recommence the supply of energy to his premises on the grounds that the installation is defective or is likely to constitute danger, he may appeal to the Inspector to test the installation and the supplier shall not, if the Inspector or, under his orders, any other officer appointed to assist the Inspector, is satisfied that the installation is free from the defect or danger complained of, be entitled to refuse supply to the consumer on the grounds aforesaid, and shall within twenty-four hours after the receipt of such intimation from the Inspector, commence, continue or recommence the supply of energy.

(2) Any test for which application has been made under the provision of sub-rule (1) shall be carried out within seven days after the receipt of such application.

(3) This rule shall be endorsed on every notice given under the provision of rules 47, 48 and 49.

53. Cost of Inspection and Test of Consumer's Installation : (1) The cost of the first inspection and the test of consumer's installation carried out in pursuance of the provisions of 47 shall be borne by the supplier and the cost of every subsequent inspection and test shall be borne by the consumer unless in the appeal under rule 52, the Inspector directs otherwise.

(2) The cost of any inspection and test made by the Inspector, at the request of the consumer or other interested party, shall be borne by the consumer or other interested party, unless the Inspector directs otherwise.

(3) The cost of each and every such inspection and test by whomsoever borne shall be calculated in accordance with the scale specified by the Central or the State Government as the case may be in this behalf.

54. Declared Voltage of supply to Consumer. Except with the written consent of the consumer or the previous sanction of the State Government a supplier shall not permit the voltage at the point of commencement of supply as defined under rule 58 to vary from the declared voltage by more than 5 percent in the case of low or medium voltage or by more than $12\frac{1}{2}$ percent in the case of high or extra-high voltage.

55. Declared Frequency of supply to Consumer : Except with the written consent of the consumer or with the previous sanction of the State Government a supplier shall not permit the frequency of an alternating current supply to vary from the declared frequency by more than 3 percent.

56. Sealing of Meters and Cut-outs : (1) A supplier may affix one or more seals to any cut-out and to any meter, maximum demand indicator, or other apparatus placed upon a consumer's premises in accordance with section 26, and no person other than the supplier shall break any such seal.

(2) The consumer shall use all reasonable means in his power to ensure that no such seal is broken otherwise than by the supplier.

(3) The word "supplier" shall for the purpose of this rule include a State Government when any meter, maximum demand indicator or other apparatus is placed upon a consumer's premises by such Government.

57. Meters, maximum demand Indicators and other apparatus on consumer's premises. (1) Any meter, or maximum demand indicator or other apparatus placed upon a consumer's premises in accordance with section 26 shall be of appropriate capacity and shall be deemed to be correct if its limits or error do not exceed 3 per cent above or below absolute accuracy at all loads in excess of one-tenth of full load and upto full load.

(2) No meter shall register at no load.

(3) Every supplier shall provide and maintain in proper condition such suitable apparatus as may be prescribed or approved by the Inspector for the examination, testing and regulation of meters used or intended to be used in connection with the supply of energy.

Provided that the supplier may with the approval of the Inspector and shall, if required by the Inspector enter into a joint arrangement with any other supplier for the purpose aforesaid.

(4) Every supplier shall examine, test and regulate all meters, maximum demand and other apparatus for ascertaining the amount of energy supplied before their first installation at the consumer's premises and at such other intervals as may be directed by the State Government in this behalf.

(5) Every supplier shall maintain a register of metres, showing the date of the last test the error recorded at the time of the test, the limit of accuracy after adjustment and final test, the date of installation, withdrawal, reinstallation etc. for the examination of the Inspector or his authorised representative.

58. Point of commencement of Supply : The point of commencement of supply of energy to a consumer shall be deemed to be the point at the outgoing terminals of the cut-outs inserted by the supplier in each conductor of every service line other than earthed or earthed neutral conductor or the earthed external conductor of concentric cable at the consumer's premises.

59. Precautions against failure of supply : Notice of Failure. (1) The lay-out of the electric supply lines of the supplier for the supply of energy throughout his area of supply shall under normal working conditions be sectionalised and so arranged, and provided with cut-outs or circuit breakers so located as to restrict within reasonable limits the extent of the portion of the system affected by any failure of supply.

(2) The supplier shall take all responsible precautions to avoid any accidental interruptions of supply and also to avoid danger to the public or to any employee or authorised person when engaged on any operation during and in connection with the installation, extension and replacement, repair and maintenance of any works.

(3) The supplier shall send to the Inspector notice of failure of supply of such kind as the Inspector may from time to time require to be notified to him and such notice shall be sent by the earliest practicable post after the failure occurs or after the failure becomes known to the supplier and shall be in such form and contain such particulars as Inspector may from time to time specify.

(4) For the purposes of testing or for any other purposes connected with the efficient working of undertaking the supply of energy may be discounted by the supplier for such period as may be necessary subject (except in case of emergency) to not less than twenty-four hours notice being given by the supplier to all classes of consumers specified by the Inspector likely to be affected by such discontinuance ; and in the event of any consumer or consumers from such classes of consumers objecting the supply of energy shall not be discontinued (except in cases of emergency), without the consent of the Inspector and subject to such conditions as he may impose.

ELECTRIC SUPPLY LINES, SYSTEMS AND APPARATUS FOR LOW AND MEDIUM VOLTAGE

60. Test for the resistance of Insulation : (1) Where any electrical supply line for use at low or medium voltage has been disconnected from a system for the purpose of addition or alternation or repair, such electric supply line shall not be reconnected to the system until the supplier or the owner has applied the test prescribed under rule 48.

(2) The provisions of sub rule (1) shall not apply to the overhead lines except overhead insulated cables unless the Inspector otherwise directs in any particular case.

61. Connection with Earth : (1) The following provisions shall apply to the connection with earth of systems at low voltage in case where the voltage normally exceeds 125 volts and of the systems at medium voltage :

- (a) The neutral conductor of a three-phase four-wire system, shall be earthed by not less than two separate and distinct connections with the earth both at the generating station and at the sub-station. It may also be earthed at one or more points along the distribution system or service line in addition to any connection with earth which may be at the consumer's premises.
- (b) In the case of a system comprising electric supply lines having concentric cables, the external conductor of such cables shall be earthed by two separate and distinct connections with earth.
- (c) The connection with earth may include a link by means of which the connection may be temporarily interrupted for the purpose of testing or for locating a fault.
- (d) (i) In a direct current three-wire system the middle conductor shall be earthed at the generating station only, and the current from the middle conductor to earth shall be continuously recorded

by means of a recording ammeter and if at any time the current exceeds one thousandth part of the maximum supply current, immediate steps shall be taken to improve the insulation of the system.

- (ii) Where the middle conductor is earthed by means of a circuit-breaker with a resistance connected in parallel the resistance shall not exceed 10 ohms and on the opening of the circuit-breaker, immediate steps shall be taken to improve the insulation of the system, and the circuit-breaker shall be reclosed as soon as possible.
 - (iii) The resistance shall be used only as a protection for the ammeter in case of earths on the system and until such earths are removed, immediate steps shall be taken to locate and remove earth.
- (e) In the case of an alternating current system there shall not be inserted in the connection with earth any impedance (other than that required solely for the operation of the switch-gear or instruments), cut out or circuit breaker, or result on any test, made to ascertain whether the current (if any), passing through the connection with earth is normal, shall be duly recorded by the supplier.
 - (f) No person shall make connection with earth by the aid of, nor shall he keep it in contact with, any water main not belonging to him except with the consent of the owner thereof and to the Inspector.
 - (g) Alternating current systems which are connected with earth as aforesaid may be electrically interconnected.

Provided that each connection with the earth is bonded to the metal sheathing and metallic armouring (if any) of the electric supply lines concerned.

(2) The frame of every generator, stationary motor, and so far as is practicable, portable motor and metallic parts (not intended as conductors) of all transformers and any other apparatus used for regulating or controlling energy and all medium voltage energy consuming apparatus shall be earthed by the owner by two separate and distinct connections with the earth.

(3) All metal casings or metallic coverings containing or protecting any electric supply-line or apparatus shall be connected with earth and shall be so joined and connected across all junction-boxes and other openings as to make good mechanical and electrical connection throughout their whole length.

Provided that where the supply is at low voltage, this sub-rule shall not apply to isolated wall tubes or to brackets, electrollers, switches, fans, regulators covers or fitting (other than portable hand lamps and portable and transportable apparatus) unless provided with earth terminal.

This sub-rule shall come into force immediately in the case of new installations and in the case of existing installations the provisions of this sub-rule shall be complied with before the expiry of a period of two years from the commencement of those rules.

(4) All earthing systems shall, before electric supply lines or apparatus are energised, be tested for electrical resistance to ensure efficient earthing.

(5) All earthing systems belonging to the supplier shall, in addition, be tested for resistance on dry day during the dry season not less than once every two years.

(6) A record of every earth test made and the result thereof shall be kept by the supplier for a period of not less than two years after the day of testing and shall be available to the Inspector when required.

62. System at Medium Voltage. Where a medium voltage supply system is employed the voltage between earth and any conductor forming part of the said system shall not, under normal conditions, exceed low voltage.

ELECTRIC SUPPLY LINES, SYSTEMS AND APPARATUS FOR HIGH AND EXTRA HIGH VOLTAGES

63. Approval by the Inspector. (1) Before making an application to the Inspector for permission

to commence supply of energy at high or extra high voltage to a person the supplier shall ensure that the high or extra-high voltage electric supply lines or apparatus belonging to him are placed in position properly joined and duly completed and examined. The supply of energy shall not be commenced by the supplier unless and until the Inspector is satisfied that the provisions of rules 65 to 69 both inclusive have been complied with and the approval in writing of the Inspector has been obtained.

Provided that the supplier may energise the aforesaid electric supply lines or apparatus for the purpose of tests specified in rule 65.

(2) The owner of any high or extra high voltage installation shall, before making application to the Inspector for approval of his installation or additions thereto, test every high or extra voltage circuit or additions thereto, other than an overhead line, and satisfy himself that they withstand the applications of the testing voltage set out in sub rule (1) of rule 65 and shall duly record the results of such tests and forward them to the Inspector.

Provided that, an Inspector may direct such owner to carry out such tests as he deems necessary or if he thinks fit, accept the manufacturer's certified tests of any particular apparatus in place of the tests required by this sub-rule.

(3) The owner of any high or extra-high voltage installation who makes any additions or alternations to his installation shall not connect to the supply his apparatus or electric supply lines, comprising the said alternations of additions have been approved in writing by the Inspector.

64. Use of Energy at high and Extra-high voltage. (1) The Inspector shall not authorise a supplier to connect a supply of energy at high or extra-high voltage to any consumer, unless.

- (a) all conductors and apparatus intended for use at high or extra-high voltage and situated on the premises of the consumer are inaccessible except to an authorized person and all operations in connection with the said conductors and apparatus are carried out only by an authorised person ;
- (b) the consumer has provided and agrees to maintain a separate building or a locked weather-proof and fire proof enclosure of agreed design and location, to which the supplier shall at all times have access, for the purpose of housing his high or extra-high voltage apparatus and metering equipment, or where the provisions of a separate building or enclosure is impracticable, the consumer has segregated the aforesaid apparatus of the supplier from any other part of his own apparatus.

Provided that such segregation shall be by the provision of fire-proof walls if the Inspector considers it to be necessary.

Provided further that in the case of an out-door installation the consumer shall suitably segregate the aforesaid apparatus belonging to the supplier from his own to the satisfaction of the Inspector.

- (c) all pole type sub-stations are constructed and maintained in accordance with rule 69.

(2) The following provisions shall be observed where energy at high or extra-high voltage is supplied, converted, transformed or used.

- (a) All conductors or live parts of any apparatus shall ordinarily be inaccessible.
- (b) All windows, at high or extra-high voltage of motors or other apparatus within reach from any position in which a person may require to be, shall be suitably protected so as to prevent danger.
- (c) Where transformer or transformers are used, suitable provision shall be made either by connecting with earth a point of the circuit and the lower voltage or otherwise, to guard against danger by reason of the said circuit becoming accidentally charged above its normal voltage by leakage from or contact with the circuit at the higher voltage.
- (d) (i) Where a sub-station or a switch-station is situated in any building and where fire in the sub-station or switch-station might involve risk to the said building and the said sub-station or switch station contains oil-immersed transformers, switches or static condensers involving the use of more than 500 gallons of oil in one chamber, provisions shall be made for suitable

oil in soak-pit and where use of more than 2,000 gallons of oil in any one oil-tank, receptacle or chamber is involved, provision shall be made for the draining away or removal, of any oil which may leak or escape from the tanks, receptacles or chambers containing the same ; special precautions shall be taken to prevent the spread of any fire resulting from the ignition of the oil from any cause and adequate provision shall be made for extinguishing fire which may occur. Spare oil shall not be stored in any such sub-station or switch-station.

- (ii) Cable trenches inside sub-stations and switch stations containing cables shall be filled with sand, pebbles or similar non-inflammable materials or completely covered with non-inflammable slabs.
- (e) Unless the conditions are such that all the conductors and apparatus for use at high or extra-high voltage may be made dead at the same time for the purpose of cleaning or for other work thereon, the said conductors and apparatus shall be so arranged that they may be made dead in sections and that work on any section made dead may be carried on by an authorised person without danger.
- (f) Adequate precautions shall be taken to prevent unauthorised access to any part of the installation designed to be electrically charged at high or extra-high voltage.

65. Voltage Tests (1) High and Extra high voltage electric supply lines (other than overhead lines) and apparatus of the supplier shall not be connected to a system for the purpose of supply or use of energy unless the insulation of the said electric supply lines and apparatus has withstood, either :

- (i) the tests prescribed in that behalf in the appropriate specifications of the Indian Standards Institution or in its absence the British Standard Institution then current ; or
- (ii) in cases where no such tests have been prescribed, the continuous application, between conductors and also between conductors and earth, during a period of one minute of the testing voltage given in sub-rule (2).

(2) For the purposes of clause (ii) of sub-rule (1)

- (a) if the normal working voltage does not exceed 1,000 volts, the testing voltages shall be 2,000 volts ;
- (b) if the normal working voltage exceeds 1,000 volts but does not exceed 11,000 volts, the testing voltage shall be double the normal working voltage ;
- (c) if the normal working voltage exceeds 11,000 volts, the testing voltage shall be normal working voltage plus 10,000 volts.

Provided that an apparatus which is not new shall be tested in such manner as the Inspector may specify.

(3) If the test prescribed in sub-rule (1) is made prior to the said electric supply lines and apparatus being placed in position for the purpose of supply of energy, the said electric supply lines and the apparatus after having been placed in position and before being connected to the system shall have withstood a further test for resistance of insulation either by the application of the tests prescribed in sub-rule (1) whenever reasonably practicable or by the application of a testing voltage of not less than 1,000 volts either alternating current or direct current between conductors and also between conductors and earth during a period of not less than one minute.

(4) Where any electric supply line (other than an overhead line) or apparatus for use at extra-high voltage has been disconnected from a system for alteration or repair, such electric supply line or apparatus shall not be reconnected to the system until the supplier has applied the test prescribed in sub-rule (3) and satisfied himself that the insulation of the electric supply line or apparatus is in sound condition.

(5) The supplier shall duly record the result of every test made under this rule.

(6) Notwithstanding the provisions of sub-rule (1) to (4) (both inclusive) the Inspector may, where he thinks fit, accept the manufacturer's certified tests in place of the tests prescribed in this rule.

66. Metal sheathed electric supply lines : Precautions against excess leakage : (1) The following

provisions shall apply to electric supply lines (other than over-head lines) of supplier for use at high or extra-high voltage :

- (a) The conductors shall be enclosed in metal sheathing which shall be electrically continuous and connected with earth, and the conductivity of the metal sheathing shall be maintained and reasonable precautions taken where necessary to avoid corrosion of the sheathing.
- (b) In the event of failure of insulation occurring between one conductor and the metal sheathing at any point along an electric supply line as aforesaid, the impedance of the relevant circuit shall be such that current resulting from such failure shall not be less than twice the value of the current for which a suitable cut-out of adequate rupturing capacity or other suitable overload protecting device has been set to operate or the current required to operate a suitable discriminative fault current relay :
Provided that the operation of the aforesaid protective device or of the discriminative fault current relay shall cause the automatic operation of a circuit-breaker of an adequate rupturing capacity.
The relevant circuit herein before referred to means the complete circuit from the source of supply to the point of failure of the insulation, including any connection with earth of the system of which the electric supply line as aforesaid forms part and any current limiting device inserted in such connection with earth ; and the source of supply means the point at which energy is given to the system or circuit of which the electric supply line as aforesaid forms part.
- (c) Where an electric supply line as aforesaid has concentric cables and the external conductor is insulated from an outer metal sheathing and connected with earth, the external conductor may be regarded as the metal sheathing for the purpose of this rule provided that, the foregoing provisions as to conductivity are complied with.

(2) Nothing in the provisions of sub rule (1) shall preclude the employment in generating stations, sub-stations and switch stations (including outdoor sub-stations and outdoor switch stations) of conductors for use at high or extra-high voltages, which are not enclosed in metal sheathing or preclude the use of electric supply-lines laid before the prescribed date to which the provisions of these rules apply.

67. Connection with earth. (1) The following provisions shall apply to the connection with earth of three phase system for use at high or extra-high voltages :

In the case of star-connected systems which earthed neutrals or delta connected system with earthed artificial neutral point :

- (a) the neutral point shall be earthed by not less than two separate and distinct connections with earth each having its own electrode at the generating station and at the sub-station and may be earthed at any other point provided that no interference of any description is caused by such earthing.
- (b) in the event of an appreciable harmonic current flowing in the neutral connection so as to cause interference with communication circuits the generator or transformer neutral shall be earthed through a suitable impedance.

(2) Single-phase high or extra-high voltage systems shall be earthed in a manner approved by the Inspector.

(3) In the case of a system comprising electric supply lines having concentric cables, the external conductor shall be the one to be connected with earth.

(4) Where a supplier proposes to connect with earth an existing system for use at high or extra-high voltage which has not hitherto been so connected with earth he shall give not less than fourteen days' notice in writing together with particulars to the telegraph-authority of the proposed connection with earth.

(5) Where the earthing lead and earth connection are used only in connection with earthing guards erected under high or extra-high voltage overhead lines where they cross a telecommunication line or a railway line, and where such lines are equipped with earth leakage relays of a type and setting approved by the Inspector, the resistance shall not exceed 25 ohms.

(6) In so far as the provisions of rule 61 are consistent with the provisions of this rule, all connections with earth shall also comply with the provisions of that rule.

68. General conditions as to transformation and control of energy. (1) Where energy at high or extra-high voltage is transformed, converted, regulated or otherwise controlled in sub-stations or switch-stations (including outdoor sub-stations or out-door switch-stations) or in street boxes constructed underground, the following provisions shall have effect :

- (a) Sub-stations and switch-stations shall preferably be erected above ground, but where necessarily constructed underground, due provision for ventilation and drainage shall be made.
- (b) Outdoor sub-stations except pole type sub-stations and out-door switch-stations shall (unless the apparatus is completely enclosed in a metal covering connected with earth, the said apparatus also being connected with the system by armoured cable) be efficiently protected by fencing not less than 2.439 metres (8 ft) in height or other means so as to prevent access to the electric supply lines and apparatus therein by an unauthorised person.
- (c) Underground street boxes (other than sub-stations) which contain transformers shall not contain switches or other apparatus, and switches, cut-outs or other apparatus required for controlling or other purposes shall be fixed in separate receptacles above ground wherever practicable.

69. Pole type sub-stations. Where platform type construction is used for a pole type sub-station and sufficient space for a person to stand on the platform is provided a substantial hand rail shall be built around the said platform and if the hand-rail is of metal, it shall be connected with earth.

Provided that in the case of pole type sub-station on wooden support and wooden platform the metal hand-rail shall not be connected with earth.

70. Condensers. Suitable provision shall be made for immediate and automatic discharge of every static condenser on disconnection of supply.

71. Additional provisions for supply to high voltage luminous tube sign installation. (1) Any person who proposes to use or who is using energy for the purpose of operating a luminous tube sign installation, or who proposes to transform or who is transforming energy to a high voltage for any such purpose shall comply with the following conditions :

- (a) All live parts of the installation (including all apparatus and live conductors in the secondary circuit, but excluding the tube except in the neighbourhood of their terminals) shall be inaccessible to unauthorised persons and such parts shall be effectively screened.
- (b) Irrespective of the method of obtaining the voltage of circuit which feeds the luminous discharge tube sign, no part of any conductor of such circuit shall be in metallic connection (except in respect of its connection with earth) with any conductor of the supply system or with the primary winding of the transformer.
- (c) All live parts of an exterior installation shall be so disposed as to protect them against the effects of the weather, and such installations shall be so arranged and separated from its surroundings as to limit, as far as possible, the spreading of fire.
- (d) The secondary circuit shall be permanently earthed at the transformer and the core of every transformer shall be earthed.
- (e) Where the conductors of the primary circuit are not in metallic connection with the supply conductors (e.g. where a motor-generator or a double wound convertor is used), one phase of such primary circuit shall be permanently earthed at the motor-generator or convertor or at the transformer.
- (f) A final sub-circuit which forms the primary circuit of a fixed luminous-discharge tube sign installation shall be reserved solely for such purpose.

- (g) A separate primary and sub-circuit shall be provided for each transformer or each group of transformers having an aggregate input not exceeding 1,000 volt-amperes, of a fixed luminous discharge-tube sign installation.
- (h) An interior installation shall be provided with suitable adjacent means for disconnecting all phases of the supply except the "neutral" in a three phase four-wire circuit.
- (i) For installations on the exterior of a building a suitable emergency fire-proof linked switch to operate on all phases except the neutral in a three phase four-wires circuit shall be provided and fixed in a conspicuous position at not more than 2.743 metres (9 ft.) above the ground.
- (j) A special "caution" notice shall be affixed in a conspicuous place on the door of every high voltage enclosure to the effect that low voltage supply must be cut off before the enclosure is opened.
- (k) Where static condensers are used, they shall be installed on the load side of the fuses and the primary (low voltage) side of the transformer.
- (l) Where static condensers are used on primary side, means shall be provided or automatically discharging the condensers when the supply is cut off.

Provided that static condensers or any circuit interrupting devices on the high or extra-high voltage side shall not be used without the approval in writing of the Inspector.

(2) The owner or user of any luminous tube sign or similar high voltage installation shall not bring the same into use without giving to the Inspector not less than 14 day's notice in writing of the intention so to do.

72. Supply to X ray and high frequency installation. (1) Any person who proposes to employ or who is employing energy for the purpose of operating an X-ray or similar high-frequency installation, shall comply with the following conditions :

1. (a) Mechanical barriers shall be provided to prevent too close an approach to any high-voltage parts of the X-ray apparatus, except the X-ray tube and its leads, unless such high-voltage parts have been rendered shock-proof by being shielded by earthed metal or adequate insulating material.
- (b) Where extra-high-voltage generators operating at 300 peak kV or more are used, such generators shall be installed in rooms separate from those containing the other equipment and any step-up transformer employed shall be so installed and protected as to prevent danger.
- (c) A suitable switch shall be provided to control the circuit supplying a generator, and shall be so arranged as to be open except while the door of the room housing the generator is locked from the outside.
- (d) X-ray tubes used in therapy shall be mounted in an earthed metal enclosure.
- (e) Every X-ray machine shall be provided with a milliammeter or other suitable measuring instrument, readily visible from the control position and connected, if practicable, in the earthed lead but guarded if connected in the high-voltage lead.
- (f) This sub-rule shall not apply to shock-proof portable units or shock-proof self-contained and stationary units.

Note. The expression "shock-proof" as applied to X-ray and high-frequency equipment, shall mean that such equipment is guarded with earthed metal so that no person may come into contact with any live part.

2. (a) In the case of non-shock-proof equipment, over-head high-voltage conductors, unless suitably guarded against personal contact, shall be adequately spaced and high-voltage leads on tilting tables and fluoroscopes shall be adequately insulated or so surrounded by barriers as to prevent inadvertent contact.
- (b) The low voltage circuit of the step-up transformer shall contain a manually operated control device having overload protection, in addition to the over-current device for circuit protection, and these

devices shall have no exposed live part and for diagnostic work there shall be an additional switch in the said circuit which shall be of one of the following types :

- (i) A switch with a spring or other mechanism that will open automatically except while held closed by the operator, or
 - (ii) a time-switch which will open automatically after a definite period of time for which it has been set.
 - (c) If more than one piece of apparatus be operated from the same high or extra high-voltage source each shall be provided with a high or extra-high-voltage switch to give independent control.
 - (d) Low frequency current carrying parts of a machine of the quenched-gap or open-gap type shall be so insulated or guarded that they cannot be touched during operation, the high-frequency circuit proper which delivers high-frequency current normally for the therapeutic purposes, being exempted.
 - (e) All X-ray generators having capacitors shall have suitable means for discharging the capacitors manually.
 - (f) Except in the case of self-contained units, all 200 peak kv, or high X-ray generators shall have a sphere-gap installed in high-voltage system adjusted so that it will break down on over-voltage surges.
3. (a) All non current-carrying metal parts of tube stands, fluoroscopes and other apparatus shall be properly earthed and insulating floors, mats or platforms shall be provided for operators in proximity to high or extra-high-voltage parts unless such parts have been rendered shock-proof.
- (b) Where short-wave therapy machines are used, the treatment tables and examining chairs shall be wholly non-metallic.
- (4) The owner of any X-ray installation or similar high-frequency apparatus shall not bring the same into use without giving to the Inspector not less than 14 days' notice in writing of his intention to do so.

OVERHEAD LINES

73. Material and Strength. (1) All conductors of over-head lines other than those specified in sub-rule (1) of rule 86 shall have a breaking strength of not less than 317.51 kg. (700 lbs.)

(2) Where the voltage is low and the span is of less than 50 ft. (15.24 metres) and is on the owner's or consumer premises, a conductor having an actual breaking strength of not less than 300 lbs. (135.08 kg.) may be used.

74. Joints. Joints of conductors of overhead lines shall be mechanically and electrically secure under the conditions of operation. The ultimate strength of joint shall not be less than 95 percent of that of the conductor and the electrical conductivity not less than that of the conductor.

75. Maximum Stresses : Factor of Safety.

(1) (a) The owner of every overhead line shall ensure that it has the following factors of safety. The minimum factors of safety for supports based on crippling load shall be as follows :

- | | |
|---|---------|
| (i) for metal supports | ... 2.0 |
| (ii) for mechanically processed concrete supports | ... 2.5 |
| (iii) for hand moulded concrete supports | ... 3.0 |
| (iv) for wood supports | ... 3.5 |

The said owner shall also ensure that the strength of the supports in the direction of the line is not less than one-fourth of the strength required in the direction transverse to the line.

Provided that in the case of latticed steel or other compound structure the factors of safety shall not be less than 1.5 under such broken wire conditions as may be specified by the state government in this behalf.

- (b) The minimum factor of safety for stay-wires, guard wires or bearer wire shall be 2.5 based on the ultimate tensile strength of the wire.
- (c) The minimum factor of safety for conductors shall be based on their ultimate tensile strength. In addition the conductor tension at 90°F without external load shall not exceed the following percentages of the ultimate strength of such conductor :

Initial unloaded tension	... 35 per cent
Final unloaded tension	... 25 per cent

Provided that in the case of conductors having cross-section of a generally triangular shape, such as conductors composed of 3 wires, the final unloaded tension at 90°F shall not exceed 30 percent of the ultimate tensile strength of such conductor.

- (2) For the purpose of calculation the factors of safety prescribed in sub-rule (1) :
- (a) the maximum wind pressure shall be such as the State Government may specify in each case ;
- (b) for the cylindrical bodies the effective area shall be taken as two-thirds of the projected area exposed to wind pressure ;
- (c) for latticed steel or other compound structure the wind pressure on the lee-side members, shall be taken as one-half of the wind pressure on the windward side members and the factors of safety be calculated on the crippling load of struts and upon the elastic limit of tension members ;
- (d) the maximum and minimum temperatures shall be such as the State Government may specify in each case.

(3) Notwithstanding anything contained in sub-rules (1) and (2) in localities where overhead lines are liable to accumulations of ice or snow the State Government may, by order in writing, specify the loading conditions for the purpose of calculating the factor of safety.

76. Clearances above ground of the lowest Conductor.

(1) No conductor of an overhead line, including service lines, erected across a street shall at any part thereof be at height less than :

- | | |
|-------------------------------------|---------------------|
| (a) for low or medium voltage lines | ...19 ft. (5.791 m) |
| (b) for high voltage lines | ...20 ft. (6.096 m) |

(2) No conductor of an overhead line including service lines erected along any street shall at any part thereof be at a height less than :

- | | |
|--------------------------------------|---------------------|
| (a) for low and medium voltage lines | ...18 ft. (5.486 m) |
| (b) for high voltage lines | ...19 ft. (5.791 m) |

(3) No conductor of an overhead line including service lines, erected elsewhere than along or across any street shall be at a height less than :

- | | |
|---|---------------------|
| (a) for low, medium and high voltage lines up to and including 11,000 volts, if bare | ...15 ft. (4.572 m) |
| (b) for low, medium and high voltage lines upto and including 11,000 volts if insulated | ...13 ft. (3.963 m) |
| (c) for high voltage lines above 11,000 volts. | ...17 ft. (5.182 m) |

(4) For extra-high voltage lines the clearance above ground shall not be less than 17 ft. (5.182 m) plus 1 foot (0.3048 m) for every 33,000 volts.

Provided that the minimum clearance along or across any street shall not be less than 20 ft. (6.096 metres).

77. Clearance between conductors and trolley wires. No conductor of an overhead line crossing a tramway or trolley bus route using trolley wires shall have less than the following clearances above any trolley wire.

- | | |
|----------------------------------|--------------------|
| (a) low and medium voltage lines | ...4 ft. (1.219 m) |
|----------------------------------|--------------------|

Provided that where an insulated conductor suspended from a bare wire crosses over a trolley wire the minimum clearance for such insulated conductor shall be 2 ft. (0.6096 m).

- (b) high voltage lines up to and including 11,000 volts ...6 ft. (1.829 m)
- (c) high voltage lines above 11,000 volts ...8 ft. (2.439 m)
- (d) extra-high voltage lines ...10 ft. (3.048 m)

78. Clearances from buildings of low and medium voltage lines and service lines. (1) Where a low or medium voltage overhead line passes above or adjacent to or terminates on any building, the following minimum clearances from any accessible point, on the basis of maximum sag, shall be observed :

- (a) For any flat roof, open balcony, verandah roof and lean-to-roof—
 - (i) When the line passes above the building, a vertical clearance of 8 feet (2.439 m) from the highest point, and
 - (ii) When the line passes adjacent to the building, a horizontal clearance of 4 feet (1.219 m) from the nearest point, and
- (b) For pitched roof.
 - (i) When the line passes above the building, a vertical clearance of 8 feet (2.439 m) immediately under the lines, and
 - (ii) When the line passes adjacent to the building, a horizontal clearance of 4 feet (1.219 m).

(2) Any conductor so situated as to have a clearance less than that specified in sub-rule (i) shall be adequately insulated and shall be attached by means of metal clips at suitable intervals to a bare earthed bearer wire having a breaking strength of not less than 7.00 lbs. (317.51 kg).

(3) The horizontal clearance shall be measured when the line is at maximum deflection from the vertical due to wind pressure.

79. Clearance from buildings of high and extra-high voltage lines. (1) Where a high or extra-high voltage over-head line passes above or adjacent to any building or part of a building it shall have on the basis of maximum sag a vertical clearance above the highest part of the building immediately under such lines, of not less than

- (a) for high voltage lines up to and including 33,000 volts ...12 ft. (3.658 m).
- (b) for extra-high voltage line 12 ft. (3.658 m) plus 1 foot (0.3048 m) for every additional 33,000 volts or part thereof.

(2) The horizontal clearance between the nearest conductor and any part of such building shall, on the basis of maximum deflection due to wind pressure be not less than

- (a) for high voltage lines up to and including 11,000 volts ...4 ft. (1.219 m)
- (b) for high voltage lines above 11,000 volts and up to and including 33,000 volts...6 ft. (1.829 m)
- (c) for extra-high voltage lines 6 ft. (1.829 m) plus 1 foot (0.3048 m) for every additional 33,000 volts, or part thereof.

80. Conductors at different voltages on same supports. Where conductors forming parts of systems at different voltages are erected on the same supports the owner shall make adequate provision to guard against danger to lines men and others from the lower voltage system being charged above its normal working voltage by leakage from or contact with the higher voltage system and the methods of construction and the clearance between the conductors of the two systems shall be subject to the prior approval of the inspector.

81. Erection of or alteration to buildings. (1) If at any time subsequent to the erection of an overhead line (whether covered with insulating material or bare), any person proposes to erect a new building or structure, whether permanent or temporary, or to make in or upon any building or structure, any permanent or temporary addition or alteration he and the contractor he employs to carry out the erection, addition or alteration, shall, if such building, structure, addition or alteration, would, during or after construction result in contravention of the provisions of rule 79 or 80 give notice in writing of his intention to the supplier, and to an Inspector and shall furnish therewith scale drawing showing the proposed building, structure, addition or alteration and scaffolding required during its construction.

(2) On receipt of such notice the supplier shall, without undue delay, so alter the overhead line as to ensure that it will not be accessible in such a manner as to contravene the provisions of rule 79 or 80 either during or after construction. In the absence of an agreement to the contrary between the parties concerned the supplier shall be entitled to recover, from the person from whom the notice was received or from the person from whom he is entitled to receive such notice, the cost of such alterations which shall be deemed to include the following items, namely :

- (a) the cost of additional material used on the alteration.
- (b) the wages of labour employed in effecting the alteration.
- (c) supervision charges to the extent of 15 percent of item (b) and
- (d) any change incurred by the supplier to complying with the provisions of section 16 in respect of such alterations.

Provided that the supplier may, before so altering the overhead line, require the person from whom the notice was received to deposit the estimated cost of such alteration, which shall in case of dispute be determined by the Inspector.

(3) No work upon such building, structure, addition or alteration shall be commenced until the Inspector has certified that neither during nor after construction the provisions of rule 79 or 80 will be contravened.

Provided that, an Inspector may, if he is satisfied that overhead line has been so guarded as to secure the protection of persons and property from injury or risk of injury, permit the work to be executed prior to the alteration of overhead line or, in the case of temporary addition or alteration, without the alteration of the overhead line.

82. Clearance General. For the purpose of computing the vertical clearance of an overhead line, the maximum sag of any conductor shall be calculated on the basis of the maximum sag in still air and maximum temperature as specified by the State Government under rule 76 (2) (d). Similarly for the purpose of computing any horizontal clearance of an overhead line, the maximum deflection of any conductor shall be calculated on the basis of the wind pressure specified by the State Government under rule 72 (2) (a).

83. Routes : Proximity to aerodrome. Overhead lines shall not be erected in the vicinity of aerodrome until the aerodrome authorities have approved in writing the route of the proposed lines.

84. Maximum Intervals between Supports. All conductors shall be attached to support at intervals not exceeding the safe limits based on the ultimate tensile strength of the conductor and the factor of safety prescribed in rule 76.

Provided that in the case of overhead lines carrying low or medium voltage conductors, when erected in, over, along or across any street, the interval shall not, without the consent in writing of the Inspector, exceed 220 feet (67.056 metres).

85. Conditions to apply where telecommunication lines and power lines are carried on same supports. (1) Every overhead telecommunication line erected on supports carrying power line shall consist of conductors each having a breaking strength of not less than 600 lbs. (272.16 kg).

(2) Every telephone used on a telecommunication line erected on supports carrying a power line shall be suitably guarded against lighting and shall be protected by cut-outs.

(3) Where a telecommunication line is erected on supports carrying a high or extra-high voltage power line arrangement shall be made to safeguard any person using the telephone against injury resulting from contact, leakage or induction between such power and telecommunication lines.

86. Lines crossing or approaching each other. (1) Where an overhead line crosses or is in proximity to any telecommunication line, the owner of the overhead line shall protect it in a manner laid down in the Code of Practice of the Power and Tele-communication Co-ordination Committee.

(2) When it is intended to erect a telecommunication line which will cross or be in proximity to an

overhead line, the person proposing to erect such telecommunication line shall give notice in writing of his intention to the owner of the overhead line and the owner of the overhead line shall, within twenty-one days of receiving such notice, provide the protection referred to in sub-rule (1).

(3) Where an overhead line crosses or is in proximity to an overhead line belonging to another person, the owner of the line which was last erected shall so protect it as to guard against the possibility of its coming into contact with the other overhead line.

(4) A person erecting or proposing to erect an overhead line may require the owner of the other overhead line to provide the protection referred to in subrule (3) within twenty one days of the receipt of the notice in that behalf.

(5) In all cases referred to in the preceding sub-rules, the expenses of making the guarding arrangement shall be borne by the person whose line was last erected.

(6) Where two lines cross, the crossing shall be made as nearly at right angles as the nature of the case admits.

(7) The guarding arrangement shall ordinarily be carried out by the owner of the supports on which it is made and he shall be responsible for its efficient maintenance.

(8) All work required to be done by or under this rule shall be carried out to the satisfaction of the Inspector.

87. Guarding. (1) Where guarding is required under these rules, the provisions of sub-rules (2) to (4) shall apply.

(2) Every guard-wire shall be connected with earth at each point at which its electrical continuity is broken.

(3) Every guard-wire shall have an actual breaking strength of not less than 635.02 kg. (1,400 lbs.) and if made of iron or steel, shall be galvanised.

(4) Every guard-wire of cross-connected system of guard-wires, shall have sufficient current carrying capacity to ensure the rendering dead, without risk of fusing of the guard-wire or wires till the contact of any line wire has been removed.

(5) Lines crossing trolley wires, in the case of a crossing over a trolley-wire the guarding shall fulfil the following conditions, namely :

(a) Where there is only one trolley-wire, two guard-wires shall be erected as in diagram 24.1 (i).

(b) Where there are two trolley-wires and the distance between them does not exceed 0.381 metre (15 inches), two guard wires shall be erected as in diagram 24.1 (ii).

(c) Where there two trolley-wires and the distance between them exceed 0.381 metre (15 inches) but does not exceed 1.219 metres (48 inches), three-guard wires shall be erected as in diagram 24.1 (iii).

(d) Where there are two trolley-wires and the distance between them exceeds 1.219 metres (48 inches) each trolley-wire, shall be separately guarded as in diagram 24.1 (iv).

(e) The rise of trolley boom shall be so limited that if the trolley leaves the trolley-wire, it shall not foul the guard-wire ; and

(f) Where a telegraph line is liable to fall or be blown down upon an arm, stay-wire or span-wire and so slide down upon a trolley-wire, guard hooks shall be provided to prevent such sliding.

88. Service lines from overhead lines. No service-line or lapping shall be taken off from an overhead line except at a point of support.

89. Earthing. (1) All metal supports of overhead lines and metallic fittings attached thereto, shall be permanently and efficiently earthed. For the purpose a continuous earth wire shall be provided and securely fastened to each pole and connected with earth ordinarily at four points in every 1.609 km (mile), the spacing between the points being as nearly equidistant as possible. Alternatively, each support and the metallic fitting attached thereto shall be efficiently earthe'd.

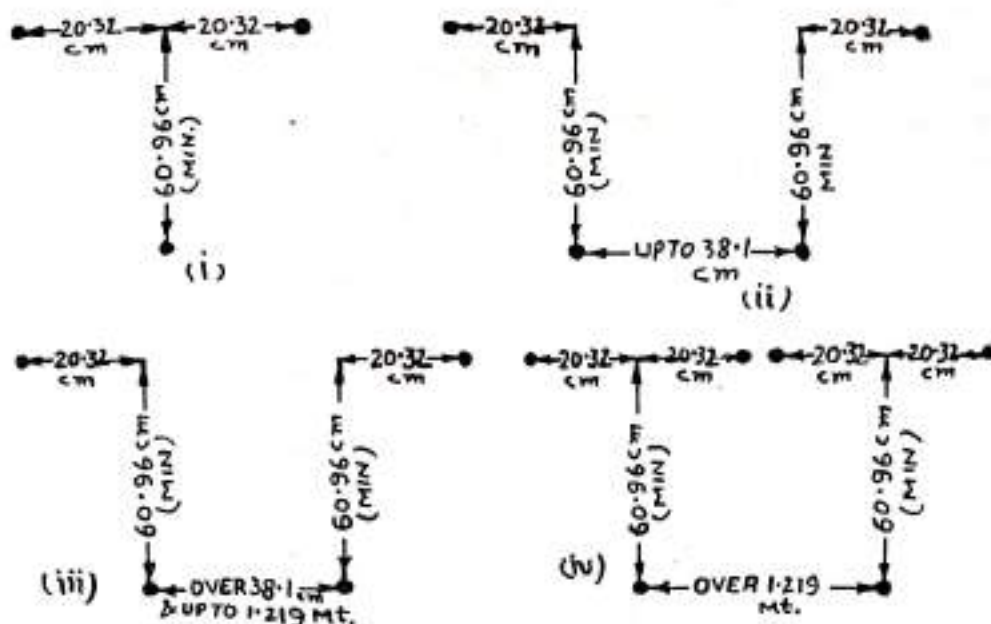

Fig. 24.1.

(2) Each stay-wire shall be similarly earthed unless an insulator has been placed in it at a height not less than 3.048 metres (10 ft.) from the ground.

90. Safety and protective devices. (1) Every over-head line (not being suspended from a dead bearer wire and not being covered with insulating material and not being a trolley wire) erected over any part of street or other public place or in any factory or mine or on any consumer's premises shall be protected with a device approved by the Inspector for rendering the line electrically harmless in case it breaks.

(2) An Inspector may by notice in writing require the owner of any such overhead line wherever it may be erected to protect it in the manner specified in sub-rule (1).

(3) The owner of every high and extra-high voltage over-head line shall make adequate arrangements to the satisfaction of the Inspector to prevent unauthorised persons from ascending any of the supports of such overhead lines without the aid of a ladder or special appliances.

91. Protection against lightning. (1) The owner of every overhead line which is so exposed as to be liable to injury from lightning shall adopt efficient means for diverting to earth any electrical surges due to lightning.

(2) The earthing lead for any lightning-arrestor shall not pass through any iron or steel pipe, but shall be taken as directly as possible from the lightning-arrestor to a separate earth electrode subject to the avoidance of bends wherever practicable.

92. Unused Overhead Lines. (1) Where an overhead line used to be ceased as an electric supply line, the owner shall maintain in a safe mechanical condition in accordance with rule 76 or shall remove it.

(2) Where any overhead line ceases to be used as an electric supply line, an Inspector may, by a notice in writing served on the owner, require him to maintain in a safe mechanical condition or to remove it within fifteen days of the receipt of the notice.

STANDARD VALUES OF VOLTAGES

General. For the sake of completeness, all the standard values of voltage given in IS-585-1962 relating to a.c. transmission and distribution systems are reproduced in this section. However it is noted that for most of the types of installations covered in subsequent part of the specification, only the lower voltage value would be relevant.

For medium and low voltage distribution system, the original recommended standard values of nominal voltage were 230 V for single phase and 230/400 V for three phase system. However during 1959 to align with IEC recommendations and in view of the economic advantages they offered values of 240 V single phase and 240/415 V three phase had been adopted.

In the case of voltage above 1 kV, the importance of highest system voltage, which are generally 10 per cent above the corresponding nominal voltage given below is recognized and product standard relate the voltage rating of equipment with respect to highest system voltages only.

Standard declared voltage

Single phase two wire system. The standard voltage shall be 240 volts.

The standard voltage for three phase system shall be as under :

415 V	voltage to neutral	240 V		
3.3 kV	11 kV	66 kV	220 kV	
6.6 kV	22 kV	110 kV	400 kV	
	33 kV	132 kV		

The standard distribution voltage shall be 220/440 V.

Voltage Limits for AC System

The voltage at any point of the system under normal conditions not depart from the declared voltage by more than the values given below :

- (a) 6 per cent in the case of low or medium voltage or
- (b) 6 percent on the higher side or 9 per cent on the lower side in case of high voltage or
- (c) 12.5 percent in the case of extra high voltage.

For installation design purpose, the limits of voltage between the system and the equipments used in the system shall be capable of operating continuously are as under :

System Voltage (U_n)	Highest Voltage (U_m)	Lowest Voltage
240 V	264 V	216 V
415 V	457 V	374 V
3.3 kV	3.6 kV	3.0 kV
6.6 kV	7.2 kV	6.0 kV
11 kV	12 kV	10 kV
22 kV	24 kV	20 kV
33 kV	36 kV	30 kV
66 kV	72.5 kV	60 kV
132 kV	145 kV	120 kV
220 kV	245 kV	200 kV
400 kV	420 kV	380 kV