

LECTURE NOTES
ON
CONCRETE TECHNOLOGY

Diploma in Civil Engineering

By

Mrs. SUSHREE SOURAVI ROUT

Lecturer, Civil Engineering Department



DEPARTMENT OF CIVIL ENGINEERING

Govt. Polytechnic, Jajpur

CT (Concrete Technology)

1.0 Concrete as a construction material:

- Concrete is one of the most commonly used building materials.
- Concrete is a mixture of portland cement, water, aggregates, and in some cases, admixtures.
- Concrete is a versatile material that can easily be mixed to meet a variety of special needs and formed to virtually any shape.

1.1 Grades of concrete.

Grades of concrete are defined by the strength and composition of the concrete, and the minimum strength the concrete should have following 28 days of initial construction. The grade of concrete is understood in measurements of MPa, where M stands for mix and the MPa denotes the overall strength.

READY MIX CONCRETE - GRADES OF CONCRETE

CLASSIFICATION	GRADE	APPLICATION	RATIO
ORDINARY	M10	PCC (Plain Cement Concrete) e.g. Levelling course, bedding for footing, concrete roads etc.	1:3:6
	M15	PCC e.g. Levelling course, bedding for footing, concrete roads etc.	1:2:4
	M20	RCC (Reinforced Cement Concrete) e.g. Slabs, beams, columns, footing etc. (for mild exposure)	1:1.5:3
STANDARD	M25	RCC (Reinforced Cement Concrete) e.g. Slabs, beams, columns, footing etc.	1:1:2
	M30	RCC e.g. Slabs, beams, columns, footing etc.	
	M35	RCC e.g. Slabs, beams, columns, footing etc.	
	M40	RCC e.g. Pre-stressed concrete, slabs, beams, columns, footing etc.	
	M45	RCC e.g. Runways, Concrete Roads (PCC), Prestressed Concrete Girders, beams, RCC Columns	
	M50	RCC e.g. Runways, Concrete Roads (PCC), Prestressed Concrete Girders, beams, RCC Columns	
	M55	RCC e.g. Prestressed Concrete Girders & Piers	
HIGH-STRENGTH	M60-	RCC work where compressive strength is required such as high rise building, long span bridges, ultra-thin white topping etc and constructions in Aggressive e.g. Spillways of dams coastal construction	
	M80		

1.2 Advantages and disadvantages of concrete.

Advantages:

- It is a relatively cheap material and has a relatively long life with few maintenance requirements.
- It is strong in compression.
- Before it hardens it is a very pliable substance that can easily be shaped.
- It is non-combustible.

Disadvantages:

- Relatively low tensile strength when compared to other building materials.
- Low ductability.
- Low strength-to-weight ratio.
- It is susceptible to cracking.

2.0 Cement:

2.1 Composition, hydration of cement, water cement ratio and compressive strength, types of cement, fineness of cement, setting time, soundness

Checking of materials is an essential part of civil engineering as the life of structure is dependent on the quality of material used. Following are the tests to be conducted to judge the quality of cement.

1. Fineness
2. Soundness
3. Consistency
4. Initial And Final Setting Time Of Cement

FINENESS

So we need to determine the fineness of cement by dry sieving as per IS: 4031 (Part 1) – 1996. The principle of this is that we determine the proportion of cement whose grain size is larger than specified mesh size.

The apparatus used are 90 μ m IS Sieve, Balance capable of weighing 10g to the nearest 10mg, A nylon or pure bristle brush, preferably with 25 to 40mm, bristle, for cleaning the sieve.

Sieve shown in pic below is not the actual 90 μ m sieve. Its just for reference.



Procedure to determine fineness of cement

- i) Weigh approximately 10g of cement to the nearest 0.01g and place it on the sieve.
- ii) Agitate the sieve by swirling, planetary and linear movements, until no more fine material passes through it.
- iii) Weigh the residue and express its mass as a percentage R_1 , of the quantity first placed on the sieve to the nearest 0.1 percent.
- iv) Gently brush all the fine material off the base of the sieve.
- v) Repeat the whole procedure using a fresh 10g sample to obtain R_2 . Then calculate R as the mean of R_1 and R_2 as a percentage, expressed to the nearest 0.1 percent. When the results differ by more than 1 percent absolute, carry out a third sieving and calculate the mean of the three values.

Reporting of Results

Water Cement Ratio

- Water Cement Ratio means the ratio between the weight of water to the weight of cement used in concrete mix.
- Normally water cement ratio falls under 0.4 to 0.6 as per IS Code 10262 (2009) for nominal mix (M10, M15 M25)
- We all know that water cement ratio will directly affect the strength of concrete. Either it increases the strength if used in correct proportion or decrease it.

Calculation of Water Quantity for Concrete

- As you can see from the Chart, the W/C Ratio varies from 0.4 to 0.7 depending on exposure conditions.
- If we need to calculate Water quantity for concrete, first find the cement content for the volume.
- If we Assume the required cement volume as 50kg,
- Required amount of water = W/C Ratio X Cement Volume
- Therefore, Required amount of water = $0.5 \times 50 \text{ kg} = 25 \text{ litres} / 50 \text{ kg}$ cement bag

Workability

- ❖ Workability means the ability of concrete to handle, transport and placing without any segregation. The concrete said to be workable if it can be easily handled, placed and transported without any segregation while placing it in site.

Testing of Cement

1. Field Testing

- ♣ Open the bag and take a good look at the cement, then it should not contain any visible lumps.
- ♣ Colour of cement should be greenish grey.
- ♣ Should get cool feeling when thrust.
- ♣ When we touch the cement, it should give a smooth & not a gritty feeling.
- ♣ When we throw the cement on a bucket full of water before it sinks the particles should flow.
- ♣ When we make a stiff paste of cement & cut it with sharp edges & kept on a glass plate under water there wont be any disturbance to the shape & should get strength after 24 hours.

2. Laboratory Testing

- ♣ Fineness test
 - ♣ Standard consistency test
 - ♣ Setting time test
 - ♣ Strength test
 - ♣ Soundness test
 - ♣ Heat of hydration test
 - ♣ Chemical composition test
- ♣ The fineness of cement has an important bearing on the rate of hydration, rate of gain of strength, evolution of heat.
 - ♣ Finer cement offers greater surface area.
 - ♣ Disadvantage of fine grinding is that it is susceptible to air set & early deterioration.
 - ♣ Maximum no. of particles in a sample of cement < 100 microns.
 - ♣ The smallest particle should have a size of 1.5 microns.
 - ♣ Large particle should have a size of 10 microns.

FINENESS TEST

Fineness of cement is tested in two ways.

1. By sieving.
2. By determination specific surface by air permeability

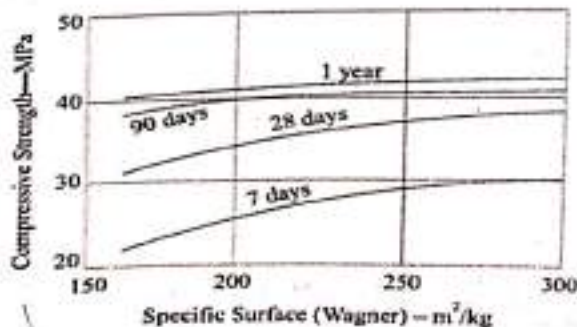

✓ 1. SIEVE TEST

- * Take correctly 100grams of cement on a standard IS sieve No.9
- * Break down the air-set lumps & sieve it & weigh it.
- * This weight shall not exceed 10% for ordinary cement.
- * Sieve test is rarely used.
- * The weight of the residue should not exceed 10% for ordinary cement.

2. STANDARD PERMEABILITY TEST

- * Principle of air permeability method is in observing the time taken for a fixed quantity of air to flow through compacted cement bed of specified dimension and porosity.

PROCEDURE

- * Cement required to make a cement bed of porosity 0.475 is calculated.
- * Pass on the air slowly at constant velocity.
- * Adjust the rate of air flow until the flowmeter shows a difference in level of 30-50cm.
- * Repeat these observation for constant h_1/h_2 . specified air flow.



3. STANDARD CONSISTENCY TEST

- * The standard consistency of a cement paste is defined as that consistency which will permit a Vicat plunger having 10 mm diameter and 50 mm length to penetrate to a depth of 33-35 mm from the top of the mould.

* Hydration of cement

- When ordinary portland cement & water are mixed together, the heat which is liberated during this process (which is actually a chemical reaction) is known as heat of hydration. The process is known as cement hydration liberating of heat. This process resulting in setting, hardening &



Vicat Apparatus

USE

Used to find out the percentage of water required to produce a cement paste of standard consistency. This is also called normal consistency (CPNC).

- ✦ For first trial, take about 500gms of cement & water of $r\%$.
- ✦ Fill it in Vicat's mould with in 3-5min.
- ✦ After filling, shake the mould to expel air.
- ✦ A standard plunger, 10 mm diameter, 50 mm long is attached and brought down to touch the surface of the paste and quickly released.
- ✦ Note the reading according to depth of penetration of the plunger.
- ✦ Conduct trials continuously by taking different water cement ratios till the plunger penetrates for a depth of 33-35mm from
- ✦ This particular percentage is known as percentage of water required to produce cement paste of standard consistency. This is usually denoted as 'P'.

SUITABLE CONDITIONS:

- ✦ Conducted in a constant temperature of $27^{\circ}\pm 2^{\circ}\text{C}$.
- ✦ Constant Humidity 90%.

SETTING TIME TEST

An arbitrary division has been made for the setting time of cement as

1. Initial setting time
2. Final setting time.

3. INITIAL SETTING TIME

- ✦ The time elapsed between the moment that the water is added to the cement, to the time that the paste starts losing its plasticity.
- ✦ Normally a minimum of 30min has maintained for mixing & handling operations.
- ✦ It should not be less than 30min.

FINAL SETTING TIME

- ✦ The time elapsed between the moment the water is added to the cement, and the time when the paste has completely lost its plasticity and has attained sufficient firmness to resist certain definite pressure.
- ✦ It should not exceed 10hours. So that it is avoided from least vulnerable to damages from external activities.

PROCEDURE:

- ✦ Vicat apparatus is used for finding the setting time
- ✦ Take 500gms of cement and add about 0.85p
- ✦ The paste should be filled within 3-5 minutes.
- ✦ Initial and final setting time is noted.

STRENGTH TEST

- ★ This is the most important of all properties of hardened cement.
- ★ Due to excessive shrinkage and cracking the strength tests are not made on neat cement paste.
- ★ Standard sand is used for finding the strength of cement.
- ★ Take sand and cement (i.e., 1:3 ratio of cement and sand) Mix them for 1min, then add water of quantity $(P/4) + 3.0\%$.
- ★ Mix three ingredients thoroughly until the mixture is of uniform colour.
- ★ The time of mixing should not be $< 3\text{min}$ and $> 4\text{min}$. Then the mortar is filled into a cube mould of 7.06cm. Compact the mortar.
- ★ Keep the compacted cube in the mould at a temperature of $27^\circ\text{C} \pm 2^\circ\text{C}$ and at least 90 per cent relative humidity for 24 hours.
- ★ After 24 hours the cubes are removed & immersed in clean fresh water until taken for testing.

SOUNDNESS TEST

- ★ It is very important that the cement after setting shall not undergo any appreciable change of volume.
- ★ This test is to ensure that the cement does not show any subsequent expansions. The unsoundness in cement is due to the presence of excess of lime combined with acidic oxide at the kiln.
- ★ This is due to high proportion of magnesia & calcium sulphate.
- ★ Therefore magnesia content in cement is limited to 6%.

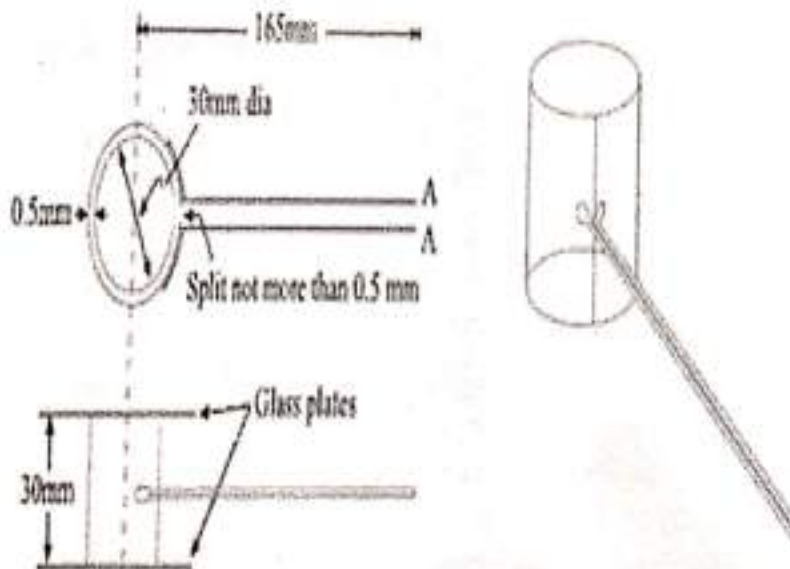

→ The cubes are tested for compressive stress for 3, 7 & 28 days.

ex: The comp. stress of OPC is 16, 22 & 33MPa for 3, 7, 28 days.

- ✓ • Aggregate is derived from naturally occurring rocks by blasting or crushing etc.
- Aggregates are the important constituents of the concrete which give body to the concrete and also reduce shrinkage.
- Aggregates occupy 70 to 80 % of total volume of concrete.

Classification of Aggregates

Aggregates are classified into following types:

- Classification based on Shape
- Classification based on Size

Classification of Aggregates based on Shape

It is of following types:

1. Rounded aggregates
2. Irregular or partly rounded aggregates
3. Angular aggregates
4. Flaky aggregates
5. Elongated aggregates
6. Flaky and elongated aggregates

1. Rounded Aggregate

- The rounded aggregates are completely shaped by attrition and available in the form of seashore gravel.
- Rounded aggregates result the minimum percentage of voids (32 – 33%) hence gives more workability.
- They require lesser amount of water-cement ratio.
- They are not considered for high strength concrete because of poor interlocking behavior and weak bond strength.



2. Irregular Aggregates

- The irregular or partly rounded aggregates are partly shaped by attrition and these are available in the form of pit sands and gravel.
- Irregular aggregates may result 35- 37% of voids.
- These will give lesser workability when compared to rounded aggregates.
- The bond strength is slightly higher than rounded aggregates but not as required for high strength concrete.



3. Angular Aggregates

- The angular aggregates consist well defined edges formed at the intersection of roughly planar surfaces and these are obtained by crushing the rocks.
- Angular aggregates result maximum percentage of voids (38-45%) hence gives less workability.
- They give 10-20% more compressive strength due to development of stronger aggregate-mortar bond.
- So, these are useful in high strength concrete manufacturing.



4. Flaky Aggregates

- When the aggregate thickness is small when compared with width and length of that aggregate it is said to be flaky aggregate.

Or ,

- when the least dimension of aggregate is less than the 60% of its mean dimension then it is said to be flaky aggregate.



5. Elongated Aggregates

- When the length of aggregate is larger than the other two dimensions then it is called elongated aggregate .
- or
- The length of aggregate is greater than 180% of its mean dimension.



6. Flaky and Elongated Aggregates

- When the aggregate length is larger than its width and width is larger than its thickness then it is said to be flaky and elongated aggregates.
- The above 3 types of aggregates are not suitable for concrete mixing.
- These are generally obtained from the poorly crushed rocks.



Classification of Aggregates Based on Size

Aggregates are classified into 2 types according to size,

- Fine aggregate
- Coarse aggregate

Fine Aggregate

- When the aggregate is sieved through 4.75mm sieve, the aggregate passed through it called as fine aggregate.
- Natural sand is generally used as fine aggregate, silt and clay are also come under this category.
- The soft deposit consisting of sand, silt and clay is termed as loam.
- The purpose of the fine aggregate is to fill the voids in the coarse aggregate and to act as a workability agent.

Fine aggregate	Size variation
Coarse Sand	2.0mm – 0.5mm
Medium sand	0.5mm – 0.25mm
Fine sand	0.25mm – 0.06mm
Silt	0.06mm – 0.002mm
Clay	<0.002

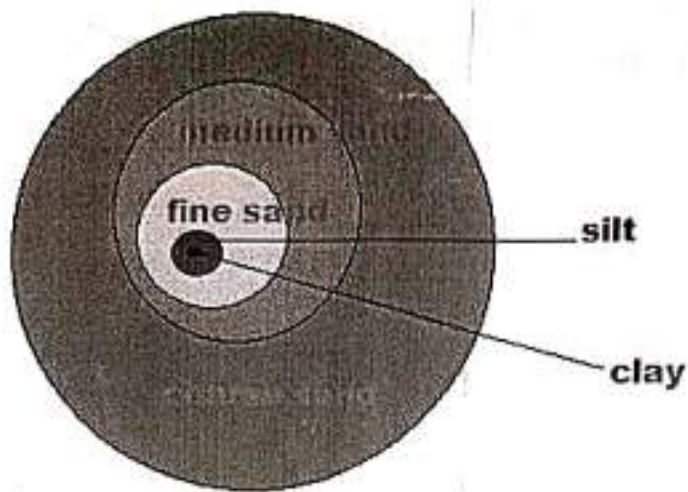

Coarse Aggregate

- When the aggregate is sieved through 4.75mm sieve, the aggregate retained is called coarse aggregate.
- Gravel, cobble and boulders come under this category.
- The maximum size aggregate used may be dependent upon some conditions.
- In general, 40mm size aggregate used for normal strengths and 20mm size is used for high strength concrete.
- The size range of various coarse aggregates given below.

Coarse aggregate	Size
Fine gravel	4mm - 8mm
Medium gravel	8mm - 16mm
Coarse gravel	16mm - 64mm

Cobbles	64mm – 256mm
Boulders	>256mm

Characteristics of aggregate

➤ Aggregates are used in concrete to provide economy in the cost of concrete. Aggregates act as filler only. These do not react with cement and water.

➤ But there are properties or characteristics of aggregate which influence the properties of resulting concrete mix. These are as follow.

1. Composition
2. Size & Shape
3. Surface Texture
4. Specific Gravity
5. Bulk Density
6. Voids
7. Porosity & Absorption
8. Bulking of Sand
9. Fineness Modulus of Aggregate
10. Surface Index of Aggregate
11. Deleterious Material
12. Crushing Value of Aggregate
13. Impact Value of Aggregate
14. Abrasion Value of Aggregate

1. COMPOSITION

Aggregates consisting of materials that can react with alkalis in cement and cause excessive expansion, cracking and deterioration of concrete mix should never be used. Therefore it is required to test aggregates to know whether there is presence of any such constituents in aggregate or not.

2. SIZE & SHAPE

- The size and shape of the aggregate particles greatly influence the quantity of cement required in concrete mix and hence ultimately economy of concrete.
- For the preparation of economical concrete mix one should use largest coarse aggregates feasible for the structure.
- IS-456 suggests following recommendation to decide the maximum size of coarse aggregate to be used in P.C.C & R.C.C mix.
- Maximum size of aggregate should be less than
 - i. One-fourth of the minimum dimension of the concrete member.
 - ii. One-fifth of the minimum dimension of the reinforced concrete member.
 - iii. The minimum clear spacing between reinforced bars or 5 mm less than the minimum cover between the reinforced bars and form, whichever is smaller for heavily reinforced concrete members such as the ribs of the main bars.
- The size & shape of aggregate particles influence the properties of freshly mixed concrete more as compared to those of hardened concrete.

3. SURFACE TEXTURE

- The development of bond strength between aggregate particles and cement paste depends upon the surface texture, surface roughness and surface porosity of the aggregate particles.
- If the surface is rough but porous, maximum bond strength develops. In porous surface aggregates, the bond strength increases due to setting of cement paste in the pores.

4. SPECIFIC GRAVITY

- The ratio of weight of oven dried aggregates maintained for 24 hours at a temperature of 100° to 110°C , to the weight of equal volume of water displaced by saturated dry surface aggregate is known as specific gravity of aggregates.

- Specific gravity is a mean to decide the suitability of the aggregate.
 - i. Low specific gravity generally indicates porous, weak and absorptive materials
 - ii. High specific gravity indicates materials of good quality.
- Specific gravity of major aggregates falls within the range of 2.6 to 2.9.

5. BULK DENSITY

- It is defined as the weight of the aggregate required to fill a container of unit volume. It is generally expressed in kg/litre.
- Bulk density of aggregates depends upon the following 3 factors.
 - i. Degree of compaction
 - ii. Grading of aggregates
 - iii. Shape of aggregate particles

6. VOIDS

- The empty spaces between the aggregate particles are known as voids.
- The volume of void equals the difference between the gross volume of the aggregate mass and the volume occupied by the particles alone.

7. POROSITY & ABSORPTION

- The minute holes formed in rocks during solidification of the molten magma, due to air bubbles, are known as pores. Rocks containing pores are called porous rocks.
- Water absorption may be defined as the difference between the weight of very dry aggregates and the weight of the saturated aggregates with surface dry conditions.

Depending upon the amount of moisture content in aggregates, it can exist in any of the 4 conditions.

- 1) Very dry aggregate (having no moisture)
- 2) Dry aggregate (contain some moisture in its pores)

- 3) Saturated surface dry aggregate (pores completely filled with moisture but no moisture on surface)
- 4) Moist or wet aggregates (pores are filled with moisture and also having moisture on surface)

8. BULKING OF SAND

- It can be defined as an increase in the bulk volume of the quantity of sand (i.e. fine aggregate) in a moist condition over the volume of the same quantity of dry or completely saturated sand.
- The ratio of the volume of moist sand due to the volume of sand when dry, is called bulking factor.
- Fine sands bulk more than coarse sand.
- When water is added to dry and loose sand, a thin film of water is formed around the sand particles. Interlocking of air in between the sand particles and the film of water tends to push the particles apart due to surface tension and thus increase the volume.
- But in case of fully saturated sand the water films are broken and the volume becomes equal to that of dry sand.

9. FINENESS MODULUS

- Fineness modulus is an empirical factor obtained by adding the cumulative percentages of aggregate retained on each of the standard sieves ranging from 80 mm to 150 micron and dividing this sum by 100.
- Fineness modulus is generally used to get an idea of how coarse or fine the aggregate is.
- More fineness modulus value indicates that the aggregate is coarser and small value of fineness modulus indicates that the aggregate is finer.

10. SPECIFIC SURFACE OF AGGREGATE

- The surface area per unit weight of the material is termed as specific surface.
- This is an indirect measure of the aggregate grading.

- Specific surface increases with the reduction in the size of aggregate particle.
- The specific surface area of the fine aggregate is very much more than that of coarse aggregate.

11. DELETERIOUS MATERIALS

- Aggregates should not contain any harmful material in such a quantity so as to affect the strength and durability of the concrete. Such harmful materials are called deleterious materials.
- Deleterious materials may cause one of the following effects
 - i. To interfere hydration of cement
 - ii. To prevent development of proper bond
 - iii. To reduce strength and durability
 - iv. To modify setting times
- Deleterious materials generally found in aggregates, may be grouped as under
 - a. Organic impurities
 - b. Clay, silt & dust
 - c. Salt contamination

12. CRUSHING VALUE

- The aggregate crushing value gives a relative measure of resistance of an aggregate to crushing under gradually applied compressive load.
- The aggregate crushing strength value is a useful factor to know the behavior of aggregates when subjected to compressive loads.

13. IMPACT VALUE

- The aggregate impact value gives a relative measure of the resistance of an aggregate to sudden shock or impact.
- The impact value of an aggregate is sometime used as an alternative to its crushing value.

14. ABRASION VALUE OF AGGREGATES

The abrasion value gives a relative measure of resistance of an aggregate to wear when it is rotated in a cylinder along with some abrasive charge.

Properties and Tests of Aggregates for Pavement Works

Aggregate Property	Test to be conducted
strength	Crushing strength test
Hardness	Abrasion test
Impact value	Impact test
Resistance against weathering	Soundness Test
Shape of aggregate	Shape test
Bitumen adhesion	Bitumen Adhesion test
Specific gravity	Specific gravity test
Water absorption	Water absorption test

1. Crushing Strength Test on Aggregates

- Aggregate crushing value gives the Crushing strength of aggregate up to which it can bear the load without fail.
- To conduct crushing strength test we need compression testing machine, cylindrical measure, plunger and Is sieves.

Procedure

- i. First sieve the sample aggregate, aggregate passing 12.5mm sieve and retaining 10mm sieve is oven dried at 100-110°C for 3-4 hrs.
- ii. The cylinder is filled with aggregate in 3 layers, 25 strokes of tamping for each later.
- iii. Note down its weight and insert the plunger and placed it on compression testing machine.
- iv. Apply the load at uniform rate of 40 tonnes load in 10 minutes.
- v. Then stop the machine and crushed aggregate is sieved through 2.36mm sieve and aggregate passing 2.36mm sieve is weighed.
- vi. Aggregate crushing value can be obtained from below formula:

$$\text{Aggregate crushing value} = (W2/W1) * 100 \%$$



2. Abrasion Test on Aggregates

- Hardness property of aggregate is determined by conducting abrasion test.
- Los Angeles abrasion testing machine is used to conduct this test.

Procedure

- i. For this test, the sample taken should be clean and dried.
- ii. The sample is weighed W_1 and placed in Los Angeles testing machine and the machine is operated.
- iii. Machine should be rotated at a speed of 20-33 revolutions per minute.
- iv. After 1000 revolutions the sample is taken out and sieved through 1.7mm sieve.
- v. Sample retained on 1.7mm is washed and dried and note down its weight W_2 .

$$\text{Aggregate abrasion value} = \{(W_1 - W_2) / W_1\} \times 100\%$$



3. Impact Test on Aggregates

Impact value of aggregate will give aggregate capability against sudden loads or forces.

It is conducted in Impact testing Machine.

Procedure

- i. For this test also aggregate passing through 12.5mm and retained on 10mm sieve is taken and oven dried.

- ii. Fill the cylinder with aggregate in 3 layers, 25 strokes of tamping for each layer. Weight w_1 noted.
- iii. The cylinder is placed in impact testing machine which consist a hammer.
- iv. After placing the cylinder, hammer is raised to 380mm and release freely.
- v. Then it will blow the aggregates. Repeat it for 15 such blows.
- vi. After that take down the sample and aggregate passing through 2.36mm sieve is weighed as w_2 .

$$\text{Aggregate impact value} = (W_2/W_1) * 100 \%$$



4. Soundness Test on Aggregates

- To determine the weathering resistance of aggregate soundness test is conducted.

- If the resistance against weathering is good for aggregate, then it will have high durability.

Procedure

- i. For soundness test we need some chemical solutions namely sodium sulphate or magnesium sulphate.
- ii. The sample of aggregate passing through 10mm sieve and retained on 300 micron sieve is taken.
- iii. Dry and weigh the sample and immerse them in the chemical solution for about 18 hours.
- iv. After that, Take the sample and dried it in oven at 100 - 110°C. repeat this procedure 5 times for one sample, and weigh the aggregate finally and note down the difference in weight loss.
- v. The weight loss should be below 12% if sodium sulphate is used, below 18% if magnesium sulphate is used.



5. Shape test on Aggregates

- Shape of aggregate is also important consideration for the construction of pavement.

- Aggregate should not contain flaky and elongated particles in it.
- If they contain this type of particles, they will affect the stability of mix.
- The percentage by weight of aggregates whose least dimension is less the $\frac{3}{5}$ th of its mean dimension is called as **flakiness index**.
- The percentage by weight of aggregate particles whose greatest dimension is 1.8th times their mean dimension is called as **elongation index**.
- In this test shape test gauges are taken and minimum of 200 pieces containing sample is passed through respective gauges. Material retained on Thickness gauge and material retained on length gauge is weighed to an accuracy of 0.1%.

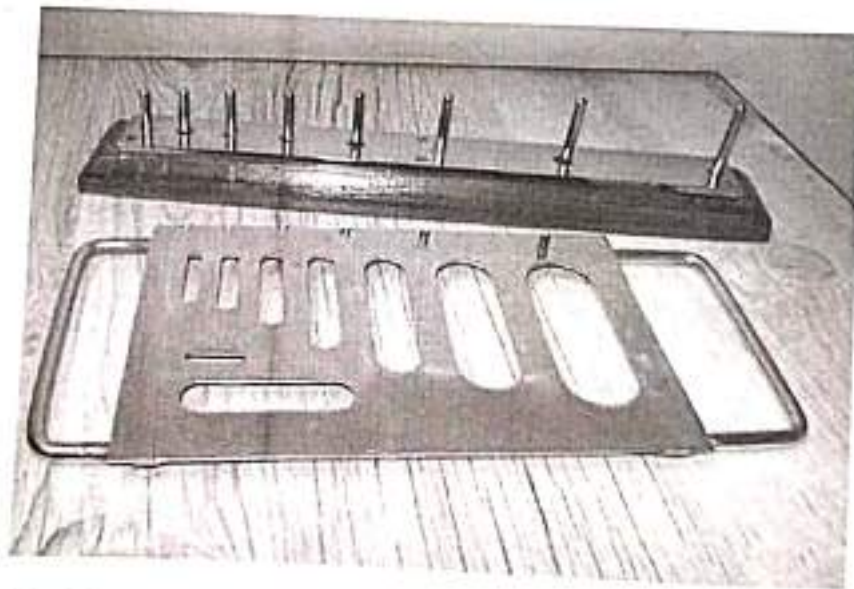

6.Bitumen Adhesion test on Aggregates

- Bitumen adhesion test will give the stripping of bitumen from the aggregate.
- In case of bitumen pavement, the bitumen should be in pure contact with aggregate.
- To attain this aggregate should be clean and dry.

- To determine the stripping value of bitumen static immersion test is conducted on aggregates.
- In this test the aggregates are coated with bitumen and dried.
- After drying they are immersed in water at 40°C for about 24 hours.
- Stripping value of aggregate should not exceed 5%.

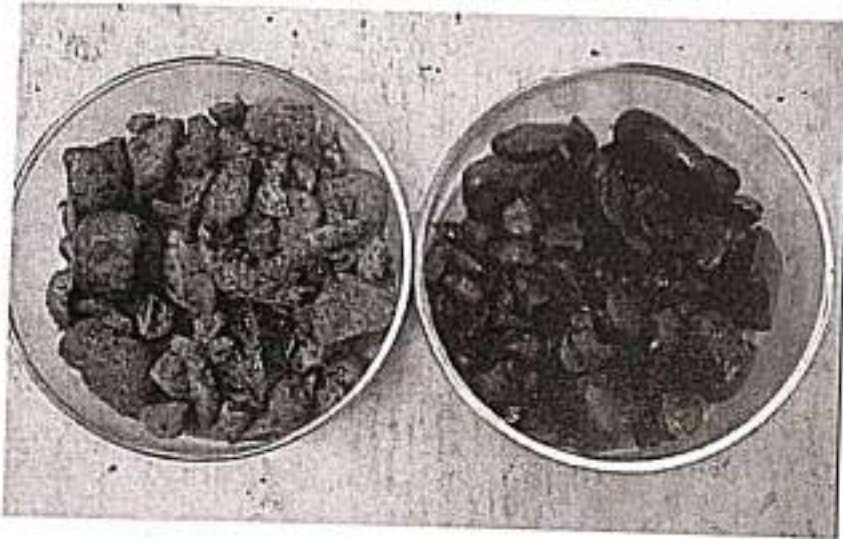

7. Specific gravity test on Aggregates

Specific gravity of an aggregate is the ratio of its mass to that of an equal volume of distilled water at specific temperature.

The specific gravity of aggregate is of two types.

- Bulk specific gravity, in which total volume of aggregates along with their void space is considered.
- Apparent specific gravity, in which the volume of aggregates without considering void spaces is taken into account.

Bulk specific gravity $G = \{\text{dry weight of aggregate} / \text{total volume of aggregate}\} / \text{density of water}$

Apparent specific gravity $G = \{\text{dry weight of aggregate} / \text{volume of aggregate without void space}\} / \text{density of water}$

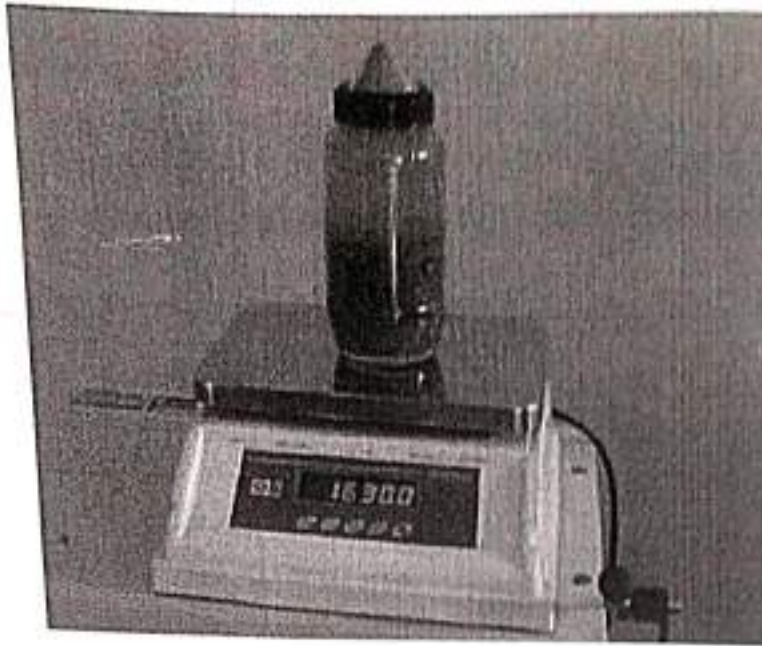

8. Water absorption test on Aggregates

- This test helps to determine the water absorption value of aggregate.
- To perform this test minimum 2 kg sample should be used.
- The sample should be cleaned and dried. Place the sample in wire basket and dip the basket in distilled water bath.
- To release the air between aggregates just lift and dip the basket for about 25 times in 25 seconds.



- Leave the basket for 24 hours and after that allowed it to drain for few minutes. Aggregates should be taken on dry cloth and exposed them to

atmosphere sunlight. After drying, weigh the aggregates W1. Then place the aggregate in oven at 100-110°C for 24 hrs. After oven drying again weight the aggregate W2.

$$\text{Water absorption of aggregates} = \{(W1-W2)/W2\} \times 100\%$$

✓ Deleterious Substances in Aggregate

1. Organic Impurities

- Organic impurities interfere with the hydration reaction
- Organic matter are mostly found in sand and consists usually of products of decay of vegetable matter
- Organic matter may removed from sand by washing

2. Clay and other Fine Materials

- Clay present on the surface of the aggregate particles in the coating form interfere with the bond between aggregate and the cement paste, adversely affecting the strength and durability of concrete .
- Other fine materials which may be present in aggregate are silt (2 to 60 μm) and crusher dust.
- Silt and dust, owing to their fineness, increase the surface area and therefore increase the amount of water necessary to wet all the particles in the mix
- In view of above, it is necessary to control the amount of clay, silt and fine dust in aggregate

3. Salts

- Sand from seashore or dredged from the sea or a river estuary, as well as desert sand contains salt

- Coarse aggregate dredged from sea also contains salt
- Salts coming through aggregates cause reinforcement corrosion and also absorb moisture from the air and cause efflorescence.

4. Unsound Particles

- Following are the two broad types of unsound particles found in aggregates:
 1. Materials fail to maintain their integrity
 2. Materials lead to disruptive expansion on freezing or even on exposure to water
- Unsound particles if present in large quantities (over 2 to 5% of the mass of the aggregate) these particles may adversely affect the strength of concrete and should certainly not be permitted in concrete which is exposed to abrasion
- Shale and other particles of low density are regarded as unsound
- Clay lumps, wood, and coal, included in aggregate, are also regarded as unsound
- Mica, gypsum, iron pyrites, etc. are also regarded as unsound. While mica is very effective in reducing strength (15% reduction in 28-d f' with 5% mica), gypsum and iron pyrites are mainly responsible for expansion of concrete

* ❖ Alkali-Aggregate Reactions

- Reaction between alkali from cement and silica or carbonate from aggregate is called "alkali-aggregate reaction"
- The most common reaction is that between the active silica constituents of the aggregate and that alkalis in cement, called as "alkali-silica reaction"

- Another type of the alkali-aggregate reaction is that between dolomitic limestone aggregates, containing carbonate, and alkalis in cement, called as "*alkali-carbonate reaction*"
- Both types of the reactions cause deterioration of concrete, mainly cracking.

❖ Alkali-Silica Reaction

- Following are the reactive forms of silica:
 - *Opal* (amorphous, i.e. shapeless)
 - *Chalcedony* (cryptocrystalline fibrous)
 - *Tridymite* (crystalline)
- Sources of the above forms of reactive silica include: opaline or chalcedonic cherts, siliceous limestones, etc
- Na_2O and K_2O are the alkalis in cement which form alkaline hydroxide in pore water facilitating the alkali-silica reaction
- As a result of alkali-silica reaction, an alkali-silicate gel is formed either in pores of aggregate or on the surface of the aggregate particles
- The gel formation on the surface of aggregate particles destroys the bond between the aggregate and cement paste.
- The swelling nature of the gel exerts internal pressure and eventually lead to expansion, cracking and disruption of the hydrated cement paste
- In order to control the alkali-silica reaction, standard tests for aggregate reactivity should be conducted on the aggregate samples

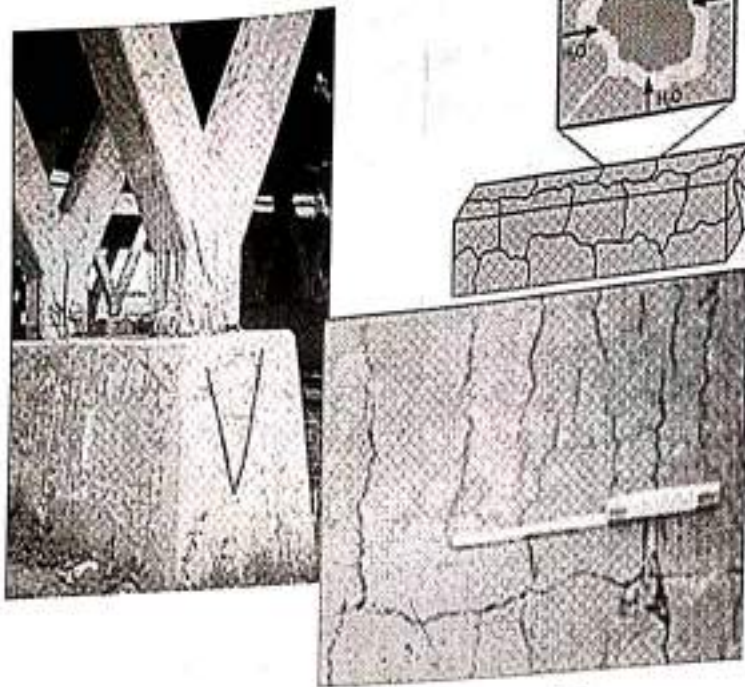

(Form of ASR deterioration in concrete)

❖ Alkali-Carbonate Reaction

- The phenomenon of the alkali-carbonate reaction is different from that of alkali-silica reaction
- In case of alkali-carbonate reaction also, gel is formed, which upon swelling cause expansion of concrete
- Gel is formed around the active aggregate particles, causing cracking within rims and leads to a network of cracks and loss of bond between the aggregate and the cement paste
- The deterioration caused by ACR is similar to that caused by ASR
- However, ACR is relatively rare because aggregates susceptible to this phenomenon are less common and are usually unsuitable for use in concrete for other reasons.
- Aggregates susceptible to ACR tend to have a characteristic texture that can be identified by petrographers.

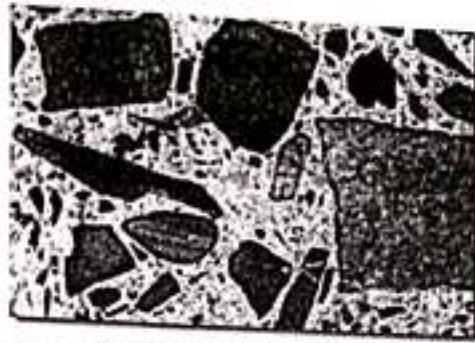

Petrography (Microscopic description) of Concrete with Aggregates susceptible to ACR.

Grading of aggregates

Grading of aggregates are determination of particle size distribution of aggregates. Grading of aggregates is an important factor for concrete mix design. These affect the concrete strength as well as durability.

Proper grading is important for concrete construction. Following tables provides details for grading limits of aggregates.

Grading Limit for Single Sized Coarse Aggregates

(Based on Clause 4.1 and 4.2 of IS: 383- 1970)

IS Sieve	Percentage passing for single sized aggregates of nominal size(mm)					
	63 mm	40 mm	20 mm	16 mm	12.5 mm	10 mm
80 mm	100	-	-	-	-	-
63 mm	85 - 100	100	-	-	-	-
40 mm	0 - 30	85 - 100	100	-	-	-
20 mm	0 - 5	0 - 20	85 - 100	100	-	-

16 mm	-	-	-	85 - 100	100	-
12.5 mm	-	-	-	-	85 - 100	100
10 mm	0 - 5	0 - 5	0 - 20	0 - 30	0 - 45	85 - 100
4.75 mm	-	-	0 - 5	0 - 5	0 - 10	0 - 20
2.36 mm	-	-	-	-	-	0 - 5

Grading Limits for Fine Aggregates

(Based on Clause 4.3 of IS: 383 - 1970)

IS Sieve Designation	Percentage Passing			
	Grading Zone I	Grading Zone II	Grading Zone III	Grading Zone IV
10 mm	100	100	100	100
4.75 mm	90 - 100	90 - 100	90 - 100	95 - 100
2.36 mm	60 - 95	75 - 100	85 - 100	95 - 100
1.18 mm	30 - 70	55 - 90	75 - 100	90 - 100

600 microns	15 - 34	35 - 59	60 - 79	80 - 100
300 microns	5 - 20	8 - 30	12 - 40	15 - 50
150 microns	0 - 10	0 - 10	0 - 10	0 - 15

Fineness Modulus of Coarse Aggregates and its Calculation

Fineness modulus of coarse aggregates represents the average size of the particles in the coarse aggregate by an index number. It is calculated by performing sieve analysis with standard sieves.

- The cumulative percentage retained on each sieve is added and subtracted by 100 gives the value of fine aggregate. Higher the aggregate size higher the Fineness modulus hence fineness modulus of coarse aggregate is higher than fine aggregate.
- Coarse aggregate means the aggregate which is retained on 4.75mm sieve when it is sieved through 4.75mm. To find fineness modulus of coarse aggregate we need sieve sizes of 80mm, 40mm, 20mm, 10mm, 4.75mm, 2.36mm, 1.18mm, 0.6mm, 0.3mm and 0.15mm.
- Fineness modulus is the number at which the average size of particle is known when we counted from lower order sieve size to higher order sieve. So, in the calculation of coarse aggregate we need all sizes of sieves.



Determination of Fineness Modulus of Coarse Aggregates

To find fineness modulus we need to perform sieve analysis and for that above mentioned sieve sizes, mechanical shaker and digital weigh scale are required.

Sample preparation

Take a sample of coarse aggregate in pan and placed it in dry oven at a temperature of 100 – 110°C. After drying take the sample weight to nearest gram.

Test Procedure for Fineness Modulus of Coarse Aggregates

- i. Arrange the sieves in descending order and put the arrangement on mechanical shaker.
- ii. It is suggested that, to know the exact value of fineness modulus for coarse aggregate, mechanical shaker will give better value than hand shaking because of more no. of sieves and heavy size particles.
- iii. After proper sieving, record the sample weights retained on each sieve and find out the cumulative weight of retained particles as well as cumulative % retained on each sieve.
- iv. Finally add all cumulative percentage values and divide the result with 100. Then we get the value of fineness modulus.

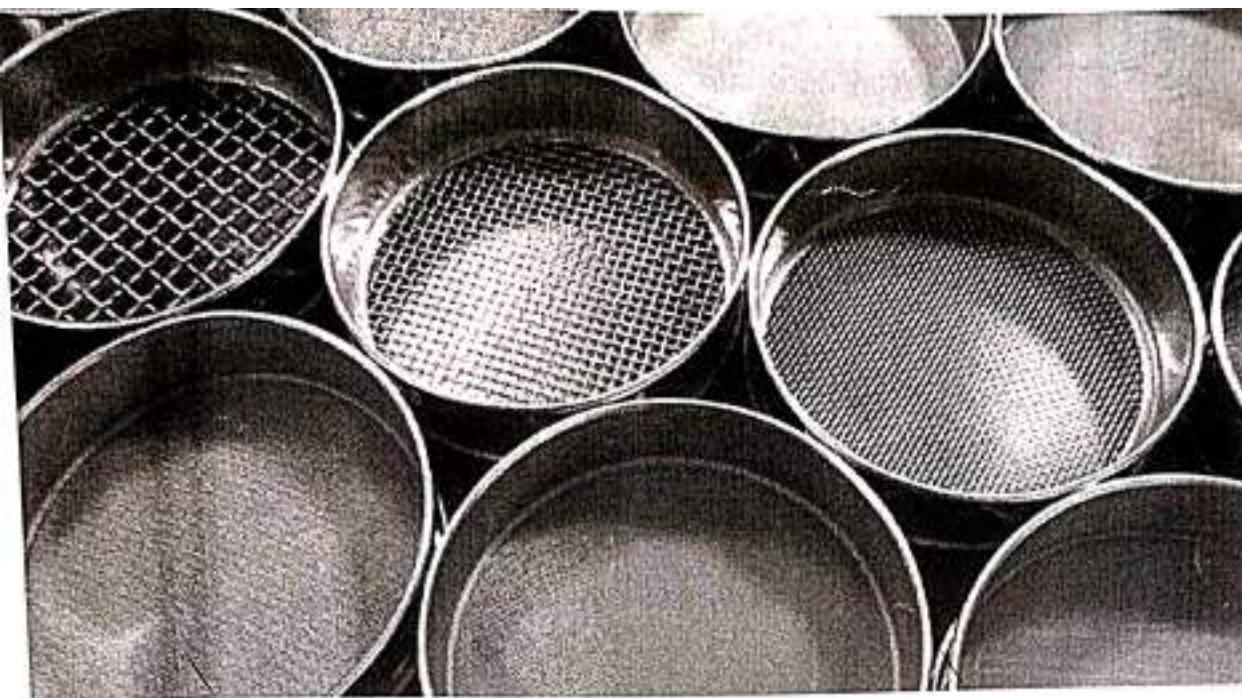

Example for Fineness Modulus Calculation

Let us say dry weight of coarse aggregate = 5000g

Values after sieve analysis are

Sieve size	Weight retained(g)	Cumulative weight retained (g)	Cumulative % retained (g)
80mm	0	0	0
40mm	250	250	5
20mm	1750	2000	40
10mm	1600	3600	72

4.75mm	1400	5000	100
2.36mm	0	5000	100
1.18mm	0	5000	100
0.6mm	0	5000	100
0.3mm	0	5000	100
0.15mm	0	5000	100
	Sum	=	717

Therefore, **fineness modulus of coarse aggregates** = $\text{sum (cumulative \% retained)} / 100 = (717/100) = 7.17$

Fineness modulus of 7.17 means, the average size of particle of given coarse aggregate sample is in between 7th and 8th sieves, that is between 10mm to 20mm.

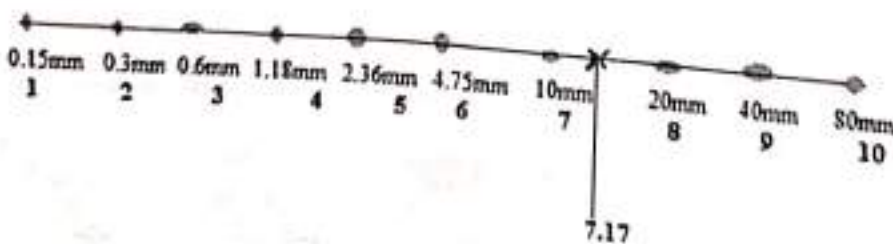

Limits of Fineness Modulus

Fineness modulus of coarse aggregate varies from 5.5 to 8.0. And for all in aggregates or combined aggregates fineness modulus varies from 3.5 to 6.5. Range of fineness modulus for aggregate of different maximum sized aggregates is given below.

Maximum size of coarse aggregate	Fineness modulus range
20mm	6.0 – 6.9
40mm	6.9 – 7.5
75mm	7.5 – 8.0
150mm	8.0 – 8.5

Fineness Modulus of Fine Aggregates and Calculations

- Fineness modulus of sand (fine aggregate) is an index number which represents the mean size of the particles in sand.
- It is calculated by performing sieve analysis with standard sieves.
- The cumulative percentage retained on each sieve is added and subtracted by 100 gives the value of fine aggregate.
- Fine aggregate means the aggregate which passes through 4.75mm sieve.
- To find the fineness modulus of fine aggregate we need sieve sizes of 4.75mm, 2.36mm, 1.18mm, 0.6mm, 0.3mm and 0.15mm.

- Fineness modulus of finer aggregate is lower than fineness modulus of coarse aggregate.



Determination of Fineness Modulus of Sand

To determine the fineness modulus, we need standard sieves, mechanical sieve shaker (optional), dry oven and digital weight scale.

Sample preparation

Take a sample of fine aggregate in pan and placed it in dry oven at a temperature of 100 – 110°C. After drying take the sample and note down its weight.

Test Procedure – Fineness Modulus of Sand

- i. Take the sieves and arrange them in descending order with the largest sieve on top.
- ii. If mechanical shaker is using then put the ordered sieves in position and pour the sample in the top sieve and then close it with sieve plate.
- iii. Then switch on the machine and shaking of sieves should be done at least 5 minutes.

- iv. If shaking is done by the hands then pour the sample in the top sieve and close it then hold the top two sieves and shake it inwards and outwards, vertically and horizontally.
- v. After some time shake the 3rd and 4th sieves and finally last sieves.
- vi. After sieving, record the sample weights retained on each sieve.
- vii. Then find the cumulative weight retained. Finally determine the cumulative percentage retained on each sieves.
- viii. Add the all cumulative percentage values and divide with 100 then we will get the value of fineness modulus.



Calculation of fineness modulus of Sand

Let us say the dry weight of sample = 1000gm

After sieve analysis the values appeared are tabulated below.

Sieve size	Weight retained (g)	Cumulative weight retained(g)	Cumulative percentage weight Retained (%)

4.75mm	0	0	0
2.36mm	100	100	10
1.18mm	250	350	35
0.6mm	350	700	70
0.3mm	200	900	90
0.15mm	100	1000	100
Total			275

Therefore, fineness modulus of aggregate = $(\text{cumulative \% retained}) / 100 = (275/100) = 2.75$

Fineness modulus of fine aggregate is 2.75. It means the average value of aggregate is in between the 2nd sieve and 3rd sieve. It means the average aggregate size is in between 0.3mm to 0.6mm as shown in below figure.

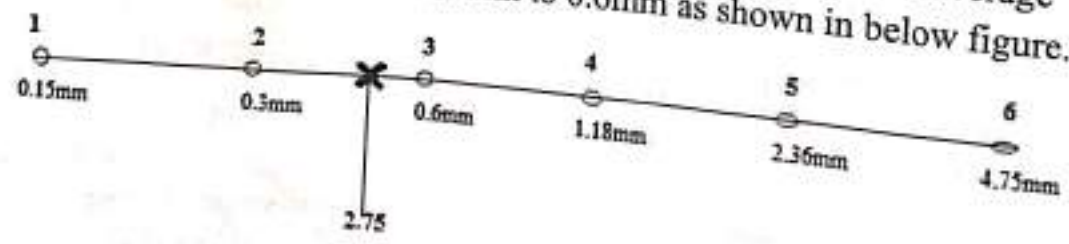

Limits of Fineness Modulus

Fineness modulus of fine aggregate varies from 2.0 to 3.5mm. Fine aggregate having fineness modulus more than 3.2 should not considered as fine aggregate. Various values of fineness modulus for different sands are detailed below.

Type of sand	Fineness modulus range
Fine sand	2.2 – 2.6
Medium sand	2.6 – 2.9
Coarse sand	2.9 – 3.2

Fineness modulus limits for various zones of sand according to IS 383-1970 are tabulated below.

Sieve size	Zone-1	Zone-2	Zone-3	Zone-4
10mm	100	100	100	100
4.75mm	90-100	90-100	90-100	95-100
2.36mm	60-95	75-100	85-100	95-100
1.18mm	30-70	55-90	75-100	90-100

0.6mm	15-34	35-59	60-79	80-100
0.3mm	5-20	8-30	12-40	15-50
0.15mm	0-10	0-10	0-10	0-15
Fineness modulus	4.0-2.71	3.37-2.1	2.78-1.71	2.25-1.35

.....

Quality of water for mixing & curing :-

- Concrete is not just another material, it is 2nd most used material on the earth after water.

- It is a composite material made up of a filler & a binder.

- The binder (cement paste) glues the filler together.

- The constituents used for the binder are cement and water, while the filler can be fine and/or coarse aggregate.

Binder = Cement + Water

• cement consists of mainly

i) Lime 75 - 77%

ii) Silica & Alumina 12 - 15%

iii) Iron oxide 0.5 to 6%

• Water consists of

i) hydrogen

ii) Oxygen (i.e. H_2O)

- Water is important because bad quality & impurities in water lead to the following problems

(i) Interfere with the setting of cement

(ii) Affect the strength of the concrete

(iii) Cause staining of its surface

(iv) Lead to corrosion of the reinforcement.

- Compare the setting time of cement and the strength of mortar cubes using the water need to be tested with the corresponding results obtained using good or distilled water.

If the tolerance is less than 10%, the water is suitable for mixing.

- (i) Water used for mixing & curing shall be clean & free from injurious amounts of oils, acids, alkalis, salts, sugar, organic materials.
- (ii) Potable water is generally considered satisfactory for mixing concrete.
(Drinking)
- (iii) Mixing & curing with sea water shall not be permitted.

- Sea water contains large quantities of chlorides. This causes dampness & efflorescence appearance on the surface of concrete.

- Sea water increases the risk of corrosion of the reinforcement.

- (iv) Drinking water generally is fit for concrete except when it has a high concentration of sodium or potassium & there is a danger of alkali-aggregate reaction.

- (v) The pH value shall not be less than 6. pH ~~value~~ of 6 to 8 which doesn't taste saline or brackish.

(vi) Salts should not exceed 500 ppm of chloride ion.

(vii) Alkali carbonates & bicarbonates should not exceed 1000 ppm.

The permissible limits for solids in water

<u>Solids</u>	<u>Permissible Limits (max)</u>
Organic	200 mg/lit
Inorganic	3000 mg/lit
Sulphates SO_4	500 mg/lit
Chlorides (Cl)	500 mg/lit
Suspended matter	2000 mg/lit

PROPERTIES OF FRESH CONCRETE

- ★ The term fresh concrete means the wet mix of concrete ingredients before they begin to set.
- ★ Fresh Concrete can be easily molded into any designed shape in construction.
- ★ The potential strength and durability of concrete of a given mix proportion is very dependent on the degree of its compaction.
- ★ It controls the long term behavior, E_c (elastic modulus), creep, and durability.

Below are the *properties of fresh concrete*:-

1. Workability

It is the ease with which freshly prepared concrete can be transported and placed for the job and compacted to a dense mass.

2. Setting

When concrete changes its state from fresh to hardened then this process is called setting.

3. Segregation

The separation of concrete ingredients from each other is known as segregation.

4. Plastic Shrinkage

This is the shrinkage that the fresh concrete undergoes till it sets completely. It may be also called initial shrinkage.

5. Thermal Shrinkage

This may be due to falling in temperature of concrete-mix from the time it laid to the the time it sets completely.

6. Thermal Expansion

In massive concrete works, when the upper layers are laid before the lower layers have completely set, there may arise a phenomenon of thermal expansions – in the lower layers.

7. Water Cement Ratio

The comprehensive strength decreases, in general, with increasing water cement ratio and vice versa

5.1 Introduction

- The strength of concrete of a given mix proportions is very seriously affected by the degree of its compaction;
- It is vital, that the consistency (ability to flow) of the mix be such that, the concrete can be transported, placed and finished sufficiently easily and without segregation.

Workability

- The ease with which concrete mixes can be compacted as completely as possible while using the lowest possible water/cement ratio.
- Should be obtained by the use of a well-graded aggregate which has the largest maximum particle size possible.
- The use of smooth and rounded, rather than irregularly shaped aggregate also increase workability.
- Air entraining admixtures improve the workability of mixes but causes a loss of strength up to about 15 percent.

Factors affecting workability

- ▶ **Water content of the mix:** Adding water increases workability and decreases strength.
- ▶ **Maximum size of aggregate:** Less surface area to be wetted and more water in medium.
- ▶ **Grading of aggregate:** Poor grading reduces the consistency.

► Shape and texture of aggregates: Smooth surfaces give better workability.

Measurement of Workability

- i. *Slump Test*: Gives good results for rich mixes.
- ii. *Compacting Factor Test*: Used for low workable concretes.
- iii. *Flow Table Test*: Used for high workable concretes.
- iv. *VeBe Test*: Used for low workable concretes (fiber reinforced concrete).

1. SLUMP TEST

- This is a test used extensively in sitework all over the world. Very useful in detecting variations in the uniformity of mix of given nominal proportions.
- Rich mixes behave satisfactorily, their slump being sensitive to variation in workability.

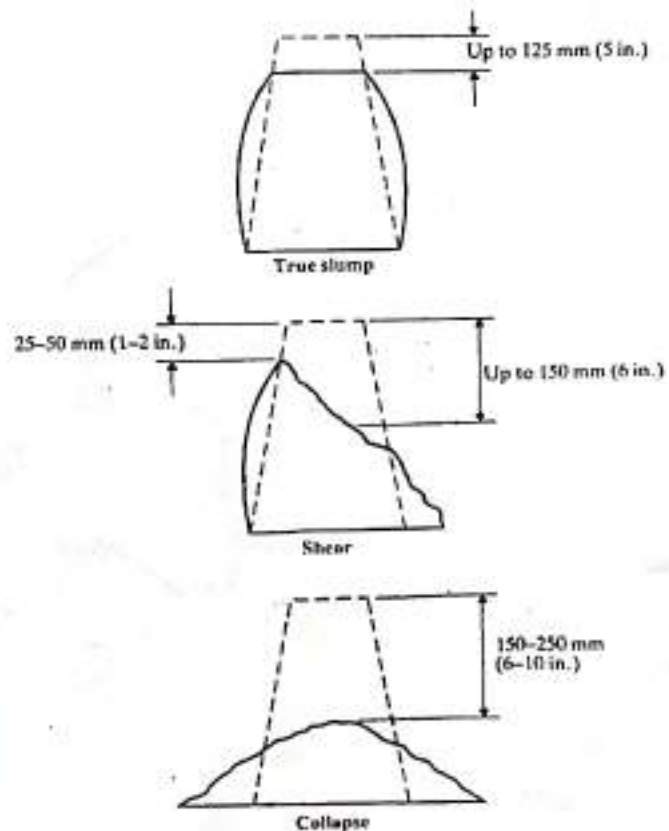
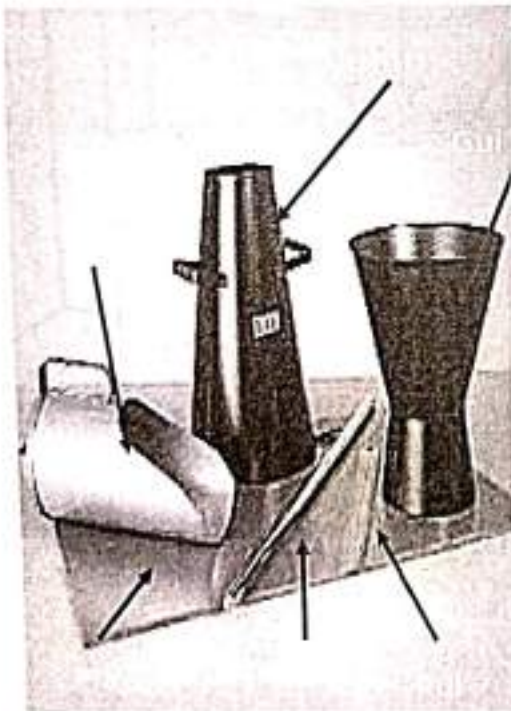

COMPACTING FACTOR TEST

- The degree of compaction, called compacting factor, is measured by the density ratio, i.e. the ratio of the density of actually achieved to the density of the same concrete fully compacted.
- Test is more sensitive at low workability.

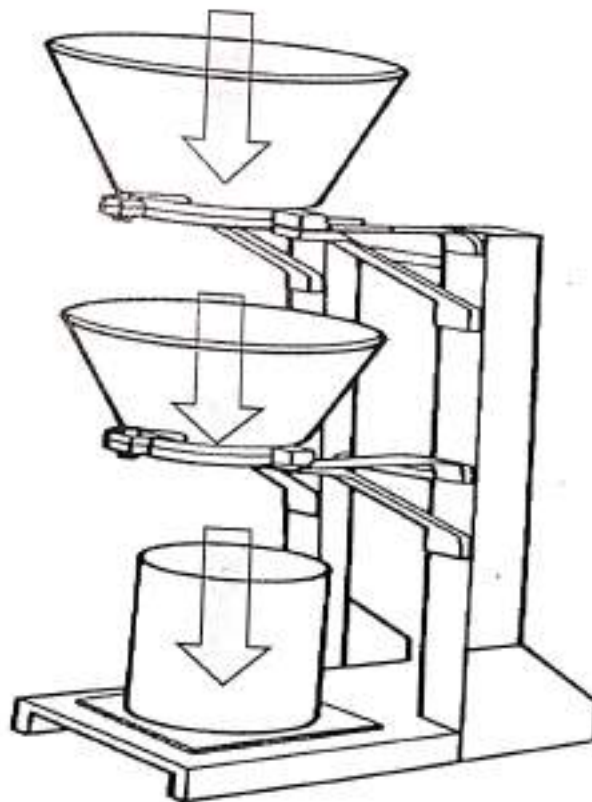

FLOW TEST

Measures the diameter of spread after vibration.

r

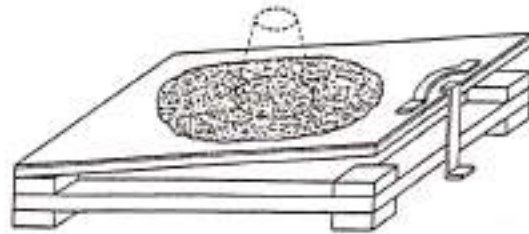
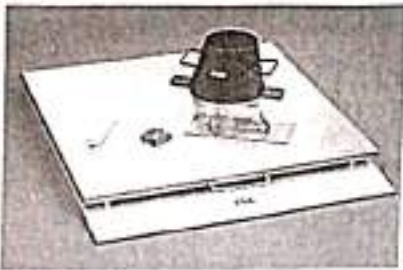

VEBE TEST

Start time after removing cone and stop counter once the transparent rider is covered with paste. Record in seconds. This is Vebe time.

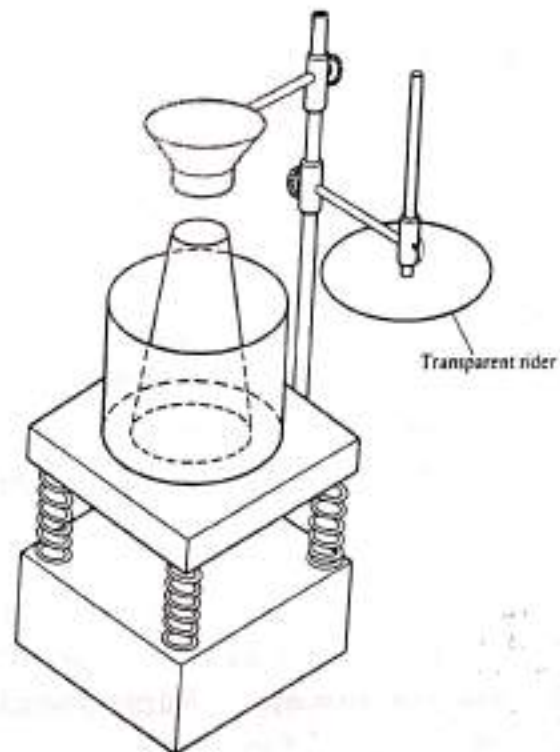
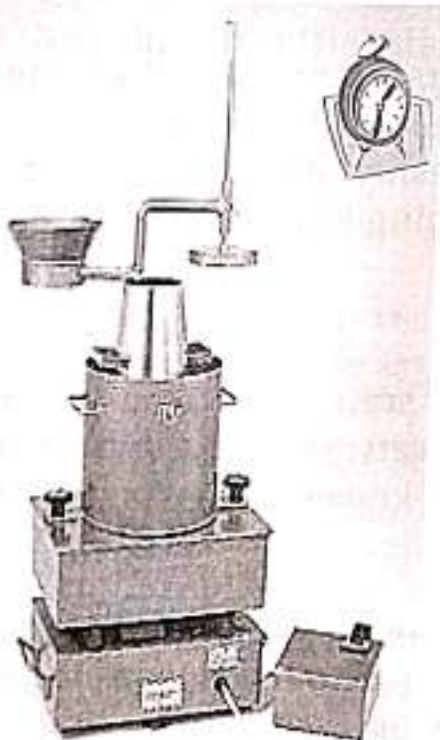

Requirements of Workability:

- ★ Workability, in the simplest language, is the ease with which freshly prepared concrete can be transported and placed for the job and compacted to a dense mass.
- ★ The fresh concrete which may be expected to give the best results must possess the property of workability. This is the most important property of fresh concrete.
- ★ Fresh concrete should be capable of spreading uniformly without inducing any segregation of the aggregates.
- ★ A workable concrete should have a right balance between the plasticity and mobility for a particular job in particular place.
- ★ To develop such a balance, you must select the right type of aggregates, proper proportioning of cement, sand, coarse aggregates, and water, and thorough mixing of the constituents.
- ★ Besides plasticity or consistency and mobility, the third most important aspect considered to define workability is the ease with which the freshly placed concrete can be compacted without developing any defects.

2. Setting:

- When concrete changes its state from fresh to hardened then this process is called setting. And the time required to complete this process is known as Setting Time of Cement.
- Setting time depends on the type of cement, aggregates, etc., used in concrete-mix. For increasing or decreasing the setting time Admixtures is used.

- The setting time for Portland cement is about 30 – 45 minutes.

3. Segregation: The separation of concrete ingredients from each other is known as segregation. This can be caused due to excessive vibration in concrete mixer machine or falling concrete from more than 1-meter height.

4. Plastic Shrinkage:

This is the shrinkage that the fresh concrete undergoes until it sets completely. It may also be called initial shrinkage.

This can be due to excessive loss of water from the concrete due to evaporation, bleeding, and soaking by formwork.

Excessive shrinkage at initial stages may develop cracks. Therefore, all precautions should be taken to avoid excessive loss of water.

5. Thermal Shrinkage:

This may be due to falling in temperature of concrete-mix from the time it laid to the time it sets completely.

Due to change in temperature, some shrinkage may be expected. Sometimes, It may be negligible on its own account.

6. Thermal Expansion:

In massive concrete works, when the upper layers are laid before the lower layers have completely set, there may arise a phenomenon of thermal expansions – in the lower layers.

This is because the heat of hydration gets accumulated in those layers and may attain magnitudes beyond acceptable limits.

7. Water Cement Ratio:

The compressive strength decreases, in general, with increasing water cement ratio and vice versa.

Hence, when minimum water is used just to ensure complete hydration of the cement, the resulting concrete will give maximum compressive strength on proper compaction.

CH-6

PROPERTIES OF HARDENED CONCRETE

- ★ Hardened concrete is a concrete which must be strong enough to withstand the structural and service loads which will be applied to it and must be durable enough to the environmental exposure for which it is designed.

It will be the strongest and durable building material.

- ★ Fully cured, hardened concrete must be strong enough to withstand the structural and service loads which will be applied to it and must be durable enough to withstand the environmental exposure for which it is designed.
- ★ If concrete is made with high-quality materials and is properly proportioned, mixed, handled, placed and finished, it will be the strongest and durable building material.

Below are the *properties of hardened concrete*:-

1. Strength
2. Creep

3. Durability
4. Shrinkage
5. Modulus of Elasticity
6. Water Tightness

1. Strength:

When we refer to concrete strength, we generally talk about compressive strength of concrete. Because, concrete is strong in compression but relatively weak in *tension* and *bending*. Concrete compressive strength is measured in pounds per square inch (psi). Compressive strength mostly depends upon amount and type of cement used in concrete mix. It is also affected by the water-cement ratio, mixing method, placing and curing.

Concrete tensile strength ranges from 7% to 12% of compressive strength. Both tensile strength and bending strength can be increased by adding reinforcement.

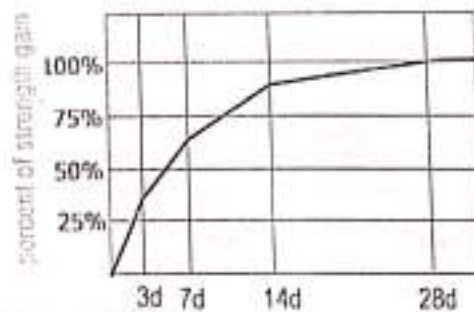

Strength gaining of concrete with age (day)

2. Creep:

Deformation of concrete structure under sustained load is defined as concrete creep. Long term pressure or stress on concrete can make it change shape. This deformation usually occurs in the direction the force is applied.

3. Durability:

Durability might be defined as the ability to maintain satisfactory performance over and extended service life. The design service life of most buildings is often 30 years, although buildings often last 50 to 100 years. Most concrete buildings are demolished due to obsolescence rather than deterioration.

Different concretes require different degrees of durability depending on the exposure environment and properties desired. Appropriate concrete ingredients, mix proportions, finishes and curing practices can be adjusted on the basis of required durability of concrete.

4. Shrinkage:

Shrinkage is the volume decrease of concrete caused by drying and chemical changes. In another word, the reduction of volume for the setting and hardening of concrete is defined as *shrinkage*.



Crack in concrete
due to shrinkage

ACE acivilengineer.com

5. Modulus of Elasticity:

The *modulus of Elasticity* of concrete depends on the Modulus of Elasticity Of the concrete ingredients and their mix proportions. As per ACI code, the modulus of Elasticity to be calculated using following equation:

$$E_c = 33w_c^{1.5} \sqrt{f_c} \text{ (psi)}$$

Where, w_c = unit weight of concrete, $\frac{145}{150}$

f_c = 28 days compressive strength of concrete

For normal weight concrete ($90 \frac{145}{150}$ to $160 \frac{145}{150}$), we assume that formula

$$E_c = 57000\sqrt{f_c}$$

6. Water tightness:

Another property of concrete is water tightness. Sometime, it's called impermeability of concrete. Water tightness of concrete is directly related to the durability of concrete. The lesser the permeability, the more the durability of concrete. Now the question is, what is the permeability of concrete?

In simple word, the capability of penetrating outer media into concrete is the permeability of concrete. Outer media means water, chemicals, sulphates, etc.

ADMIXTURES

- Concrete admixture is defined as a material other than water, aggregate and cement, added to the batch immediately before or during its mixing, to modify one or more of the properties of concrete in the plastic or hardened state.

- Functions

To modify properties of fresh concrete

- (i) Increase workability without increasing water content or decrease water content at the same workability
- (ii) Retard or accelerate the time of initial setting.
- (iii) Reduce segregation
- (iv) Modify the rate or capacity for bleedings
- (v) Improve pumpability

To modify properties of hardened concrete

- (i) Accelerate the rate of strength developed at early ages.
- (ii) Increase strength (compressive, tensile or flexural)
- (iii) Increase durability or resistance to severe condition of exposure.
- (iv) Decrease permeability of concrete
- (v) Increase bond of concrete to steel reinforcement.
- (vi) Increase bond b/w existing & new concrete
- (vii) Improve impact resistance & abrasion resistance.
- (viii) Inhibit corrosion of embedded metal.
- (ix) Produce colored concrete.

- Classification of admixtures of concrete

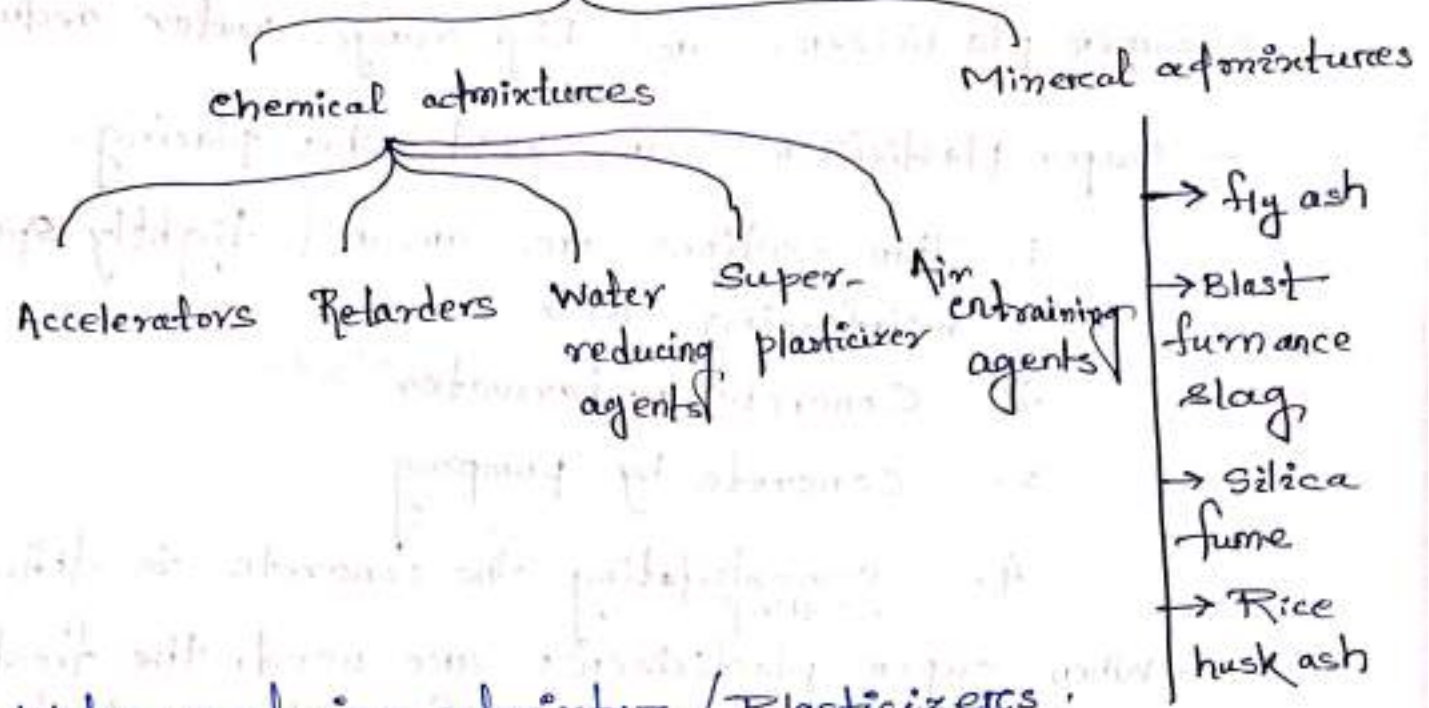

Water reducing admixture / Plasticizers :

- Water reducers can result in 3 things
 1. Increased slump at constant w/c ratio
 2. Increased strength by lowering the water content.
 3. Reduce cost of cement

- Water reducers increase the mobility of the cement particles in the plastic mix, allowing same workability to be achieved at lower water content

- examples :

- Ligno-sulphonates (natural polymer from wood processing in paper industry)
- hydrocarbolic acid
- Salts of calcium or sodium

Super-plasticizers :

- Super plasticizers are high range water reducers.

- Super plasticizers are used when placing

1. Thin sections or around tightly spaced reinforcing steel.

2. Concrete underwater

3. Concrete by pumping

4. Consolidating the concrete is difficult.
(setting)

- When super-plasticizers are used, the fresh concrete stays workable for only a short period of time (30min to 60min), which is why they are usually added at the site.

- examples :

• Sulphonated melamine formaldehyde condensates (SMF)

• Sulphonated naphthalene formaldehyde condensates (SNF)

• Polycarboxylate ether superplasticizer (PCE)

Retarding concrete admixture :

- It is used to delay the initial set of concrete

1. To offset the effect of hot weather.

2. Allow for unusual placement or long haul distance (transported to long distance)

3. Provide time for special finishes.

- examples :

- Calcium Ligno sulphonates
- Carbohydrate derivatives

Accelerating admixture:

- It is used to reduce the time required to develop final strength characteristics in concrete.

1. Reduce the amount of time before finishing operations begin
2. Reduce curing time
3. Increase rate of strength gain
4. Offset effect of cold weather

- ex.:

Calcium chloride is the most widely used accelerator.

$CaCl_2$ by weight Initial set time in hrs

0%

6

1%

3

2%

2

Air entraining Admixture:

- It produces tiny air bubbles in the hardened concrete to provide space for the water to expand upon freezing.

- Used to increase workability & frost resistance

ex: Vincol resin (salt of wood resins)
Synthetic detergents
Fatty & resinous acids

Effects of mineral admixtures on fresh concrete

- (a) Water requirements \longrightarrow Fly ash reduces water requirement
Silica fume increases water "
- (b) Air content \longrightarrow Fly ash & silica fume reduce air content
- (c) Workability \longrightarrow Fly ash, ground slag increase the workability
Silica fume reduces workability
- (d) Hydration \longrightarrow Fly ash reduces heat of hydration
- (e) Set time \longrightarrow Fly ash (class F & class C), natural pozzolans (class N), blast furnace slag increase set time.

Fly ash = Ash produced from burning of powdered coal

Silica fume = By product of producing silicon metal or ferrosilicon alloys

Ground-Granulated blast-furnance slag (GGBS) = molten iron slag is obtained by quenching (rapid cooling) from a blast furnace in water to produce granular product, dried & ground to fine powder.

Effect of mineral admixtures on hardened concrete

- (1) Strength \longrightarrow Fly ash increases the ultimate strength but reduces rate of strength gain.
Silica fume has less effect on rate of strength gain than pozzolans.
- (2) Drying shrinkage & creep \longrightarrow Low concentrations usually have single effect. High concentrations of ground slag or fly ash may increase shrinkage.
Silica fume reduce shrinkage.
- (3) Permeability & absorption \longrightarrow Generally it reduces permeability & absorption.
Silica fume is effective.
- (4) Alkali-aggregate reaction \longrightarrow Generally it reduces reactivity.
- (5) Sulphate resistance \longrightarrow Improved due to reduced permeability.

CEMENT CONCRETE MIX DESIGN

Methods of Concrete Mix Design

- I.S. Method
- British Method
- A.C.I. Method etc.

These Methods are based on two basic assumptions

- ➔ **Compressive Strength of Concrete is governed by its Water-Cement Ratio**
- ➔ **Workability of Concrete is governed by its Water Content**



Data required for concrete mix design

1. **Grade of Concrete**
Eg: RCC-M30-A20
2. **Slump required in mm**
Eg: 25 – 75 mm
3. **Degree of Site Control**
Eg: Good
4. **Type of Exposure**
Eg: Moderate
5. **Grade of Cement**
Eg: OPC 43 Grade

Workability (Clause 7.1, IS:456-2000)

Placing Conditions	Degree of Workability	Slump (mm)
1	2	3
Blinding Concrete; Shallow Sections; Pavements using pavers	Very Low	See 7.1.1
Mass Concrete; Lightly reinforced sections in Slabs, Beams, Walls, Columns; Floors; Hand placed Pavements; Canal lining; Strip Footings	Low	25-75
Heavily reinforced sections in Slabs, Beams, Walls, Columns; Slip form work; Pumped Concrete. ✓	Medium	50-100
Trench fill; In-Situ Piling; Tremie Concrete	High	100-150

Degree of Site Control (Table 8, IS:456-2000)

- Good** Site control having proper storage of cement;
weigh batching of all materials;
Controlled addition of water,
regular checking of all materials,
aggregate grading and moisture content;
And periodical checking of workability and strength.
- Fair** Site control having deviation from the above.

Approximate Quantity of Materials required for concrete mix design

- 1. Cement : 200 Kg.**
- 2. Fine Aggregate : 240 Kg.**
- 3. Coarse Aggregate : 180 Kg. (20 mm)
180 Kg. (10 mm)**

Type of Exposure (Table 3, IS:456-2000)

Sl. No.	Environment	Exposure Conditions
1	2	3
i)	Mild	<p>Concrete surfaces protected against weather or aggressive conditions, except those situated in coastal area.</p> <p>Concrete surfaces sheltered from severe rain or freezing whilst wet.</p>
ii)	Moderate	<p>Concrete exposed to condensation and rain.</p> <p>Concrete continuously under water.</p> <p>Concrete in contact or buried under non-aggressive soil/ground water.</p> <p>Concrete surfaces sheltered from saturated salt air in coastal area.</p>
iii)	Severe	<p>Concrete surfaces exposed to severe rain, alternate wetting and drying or occasional freezing whilst wet or severe condensation.</p> <p>Concrete completely immersed in sea water.</p> <p>Concrete exposed to coastal environment.</p>
iv)	Very Severe	<p>Concrete exposed to sea water spray, corrosive fumes or severe freezing conditions whilst wet.</p> <p>Concrete in contact with or buried under aggressive sub-soil/ground water.</p>
v)	Extreme	<p>Surface of members in tidal zone.</p> <p>Members in direct contact with liquid/solid aggressive chemicals.</p>

II. FINE AGGREGATE

1. Sieve Analysis

Sieve Size % Passing Specifications for Zone-II
As per IS:383-1970

10.0 mm	100	100
4.75 mm	100	90-100
2.36 mm	98	75-100
1.18 mm	65	55-90
600 micron	42	35-59
300 micron	8	8-30
150 micron	0	0-10

2. Specific Gravity : 2.60
3. Unit Weight in Kg/Cu.m
- a) Loose : 1460
 - b) Rodded : 1580
4. Materials Finer than 75 micron : 1.00 3 Max
(% by weight)

STEPS INVOLVED IN CONCRETE MIX DESIGN

✓ **Step I:- Determine the physical properties of concrete ingredients.**

I. CEMENT (OPC 43 Grade)

Sl. No.	Particulars of Test	Result	Specifications As per IS:8112-1976
1	Standard consistency (% by weight)	25.6	
2	Setting Time in minutes		
	a) Initial	95	30 Minimum
	b) Final	210	600 Maximum
3	Compressive Strength in N/sq.mm at the age of		
	a) 3 days	24	23 Minimum
	b) 7 days	35	33 Minimum
	c) 28 days	46	43 Minimum
4	Specific Gravity	3.00	
5	Fineness in Sq.m/Kg	337	225 Minimum

IV. MECHANICAL PROPERTIES

Sl. No.	Particulars of Test	Result	Specifications As per IS: 383-1970
1	Crushing Value in %	28	30 Maximum ✓ For wearing surfaces 45 Maximum ✓ For other concrete
2	Impact Value in %	24	30 Maximum For wearing surfaces 45 Maximum For other concrete
3	Los Angeles Abrasion Value in %	30	30 Maximum For wearing surfaces 50 Maximum For other concrete

III. 20.0mm COARSE AGGREGATE

1. Sieve Analysis

Sieve Size	% Passing	Specifications As per IS:383-1970	
		Graded	Single Sized
40.00mm	100	100	100
20.00mm	90	95-100	85-100
10.00mm	3	25-55	0-20
4.75mm	0	0-10	0-5

2. Specific Gravity : 2.65

3. Unit Weight in Kg/Cu.m

a) Loose : 1467

b) Rodded : 1633

VI. BLENDING OF COARSE AGGREGATE:

Sieve size (mm)	IS:383-1970 Specifications (Graded)	20 mm <i>egg</i> size	10 mm <i>egg</i> size	60%+40% <i>20mm egg</i>	50%+50% <i>10mm egg</i>
40	100	100	100	100	100
20	95-100	90	100	94	95
10	25-55	3	85	40	44
4.75	0-10	0	19	7	10

V. 10.0mm COARSE AGGREGATE

1. Sieve Analysis

Sieve Size	% Passing	Specifications As per IS:383-1970	
		Graded	Single Sized
12.50mm	100	-	100
10.00mm	85	-	85-100
4.75mm	19	-	0-20
2.36mm	0	-	0-5

2. Unit Weight in Kg/Cu.m

- a) Loose : 1427
- b) Rodded : 1587

Values of t

Accepted proportion of low results	t
1 in 5, 20%	0.84
1 in 10, 10%	1.28
1 in 15, 6.7%	1.50
1 in 20, 5%	1.65✓
1 in 40, 2.5%	1.86
1 in 100, 1%	2.33

✓ Step II:- Compute Target Mean Compressive Strength:

$$F_{ck} = f_{ck} + t * S$$

F_{ck} = Target Mean Compressive Strength at 28 days in
N/Sq.mm $\frac{N}{mm^2}$

f_{ck} = Characteristic Compressive Strength at 28 days in
N/Sq.mm $\frac{N}{mm^2}$

S = Standard Deviation in N/Sq.mm

t = A Statistic, depending on accepted proportion of
low results.
= 1.65 for 1 in 20 accepted proportion of low
results

- ✓ Step III:- Select the Water-Cement ratio of trial mix from experience

S. No.	Concrete Grade	Minimum expected W/C
1	M10	0.9
2	M15	0.7
3	M20	0.55
4	M25	0.50
5	M30	0.45
6	M35	0.40
7	M40	0.35
8	M45	0.30

Assumed Standard Deviation
(Table 8, IS:456-2000)

Grade of Concrete	Assumed Standard Deviation (N/Sq.mm)	
	Good Site Control	Fair Site Control
M10, M15	3.5	4.5
M20, M25	4.0	5.0
M30, M35 M,40,M45 M50	5.0	6.0

Approximate water content (Kg)
per cubic metre of concrete
(Table 32, SP:23-1982)

Slump (mm)	Maximum Size of Aggregate (mm)		
	10	20 ✓	40
30-50 ✓	205	185	160
80-100	225	200	175
150-180	240	210	185

✓ Step IV:- Select the water content per cubic metre of concrete from table 2 of I.S: 10262-2009.

Maximum size of Aggregate (mm)	Water Content per cubic metre of concrete (Kg)
10	208
20	186
40	165

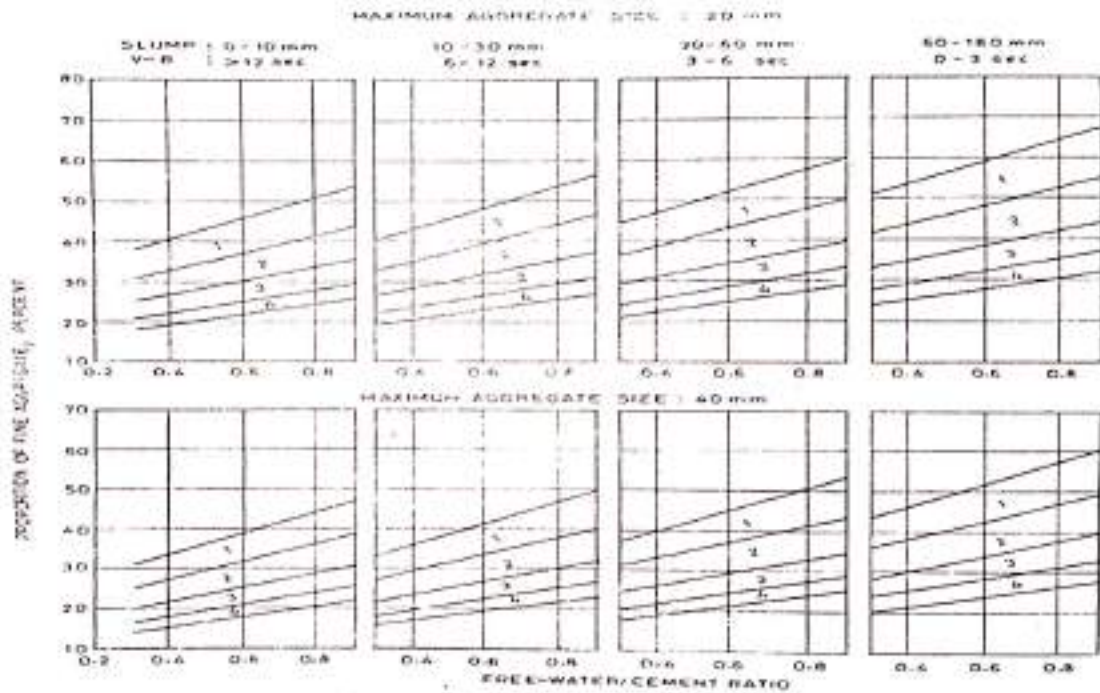

Fig. 45 Recommended Proportions of Fine Aggregate for Grading Zones 1, 2, 3 and 4

Volume of Coarse Aggregate per
Unit Volume of Total Aggregate
(Table 3, IS:10262-2009)

Maximum Size of Aggregate (mm)	Volume of Coarse Aggregate per Unit Volume of Total Aggregate			
	Zone IV	Zone III	Zone II	Zone I
10	0.50	0.48	0.46	0.44
20 ✓	0.66	0.64	0.62	0.60
40	0.75	0.73	0.71	0.69

Step VI:- Then we find the quantities of Fine & Coarse aggregate by absolute volume method.

$$V = (W+C/S_c + (1/p) * (fa/S_{fa})) * (1/1000) \quad - \text{ (Eq.1)}$$

and

$$V = (W+C/S_c + (1/(1-p)) * (ca/S_{ca})) * (1/1000) \quad - \text{ (Eq.2)}$$

Where

V = Absolute volume of fresh concrete = 1 m³

W = Mass of Water (Kg) per m³ of concrete

C = Mass of Cement (Kg) per m³ of concrete

p = Percentage of fine aggregate.

fa = Mass of fine aggregate

ca = Mass of coarse aggregate

S_c = Specific gravity of cement.

S_{fa} = Specific gravity of fine aggregate.

S_{ca} = Specific gravity of coarse aggregate.

✓ Step V:- Compute the quantity of cement as follows.

$$\begin{aligned}\text{Cement} &= \frac{\text{Water}}{\text{W/C Ratio}} \\ &= 185 / 0.45 = 411 \text{ Kg.}\end{aligned}$$

Substituting the values in Eq(2), we get

$$1000 = 185 + 411/3.0 + (1/0.64) * ca /2.65)$$

$$= 185 + 137 + ca/1.696$$

$$= 322 + ca/1.696$$

$$ca = (1000 - 322) * 1.696$$

$$= 678 * 1.696$$

$$= 1150 \text{ Kg.}$$

Substituting the values in Eq(1), we get

$$1000 = 185 + 411/3.0 + (1/0.36) * fa /2.6)$$

$$= 185 + 137 + fa/0.936$$

$$= 322 + fa/0.936$$

$$fa = (1000 - 322) * 0.936$$

$$= 678 * 0.936$$

$$= 635 \text{ Kg.}$$

- ✓ Step VII:- Make slump trials to find out the actual weight of water to get required slump. Make corrections to the water content & %FA, if required.
- ✓ Step VIII:- Compute 2 more trial mixes with W/C ratios as 0.40 & 0.50, taking %FA as 34% and 38% respectively.

Mix Design:

- Step-1 Properties of concrete ingredients
- Step-2 Compute target mean strength $f_{ck} = f_{ck} + t_s$
- Step-3 W/c ratio of trial mix
- Step-4 Water content from table as per aggregate size
- Step-5 Quantity of cement = $\frac{\text{Step 4}}{\text{Step 3}}$
- Step-6 Quantity of FA & CA
- Step-7 Change slump value, correction to % FA, water content
- Step-8 2 more trial mix for % FA = 0.34, W/c ratio = 0.4 ✓
= 0.38, = 0.5 ✓
- Step-9 3 cubes for each trial mix
- Step-10 Compressive strength test at 28 days
- Step-11 Graph Strength Vs cement-water ratio

So the mix proportion works out to be

W : C : fa : ca

= 185 : 411 : 635 : 1150

= 0.45 : 1 : 1.55 : 2.80

This mix will be considered as Trial Mix No.2

Trial Mix No. 3:-

$$\text{Cement} = 185 / 0.5 = 370 \text{ Kg.}$$

Substituting the values in Eq(1), we get

$$1000 = 185 + 370/3.0 + (1/0.38) * fa /2.6)$$

$$fa = 683 \text{ Kg.}$$

Substituting the values in Eq(2), we get

$$1000 = 185 + 370/3.0 + (1/0.62) * ca /2.65)$$

$$ca = 1136 \text{ Kg.}$$

So the mix proportion works out to be

$$W : C : fa : ca$$

$$= 185 : 370 : 683 : 1136$$

$$= 0.5 : 1 : 1.85 : 3.07$$

Trial Mix No. 1:-

$$\text{Cement} = 185 / 0.4 = 462.5 \text{ Kg.}$$

Substituting the values in Eq(1), we get

$$1000 = 185 + 462.5/3.0 + (1/0.34) * fa / 2.6$$

$$fa = 584 \text{ Kg.}$$

Substituting the values in Eq(2), we get

$$1000 = 185 + 462.5/3.0 + (1/0.66) * ca / 2.65$$

$$ca = 1156 \text{ Kg.}$$

So the mix proportion works out to be

$$\textcircled{W} : \textcircled{C} : fa : ca$$

$$= 185 : 462.5 : 584 : 1156$$

$$= 0.4 : 1 : 1.26 : 2.50$$

28 Days Compressive Strengths of Trial Mixes

W/C Ratio	C/W Ratio	Compressive Strength (Kg/Cm ²)
0.40	2.50	457
✓ 0.45	2.22	✓ 420 ✓
0.50	2.00	360

✓ Step IX:- Cast atleast 3 cubes for each trial mix.

✓ Step X:- Test the cubes for compressive strength at 28 days.

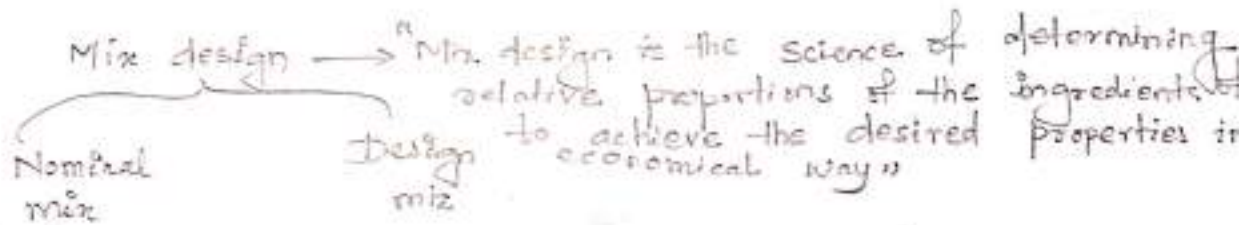

- Mixes of fixed proportions, IS 456-2000 permits nominal mixes for concrete of strength M20 or lower

- Designed on the basis of requirements of the concrete in fresh & hardened state