

TABLE OF CONTENTS

Sl. No	Name of the Experiment	Pages
1	Identification of single core (SC), twin core (TC), three cores (3c), four cores (4c); copper and aluminum PVC, VIR & Weather proof (WP) wire and prepare Britannia T joint and Married joint	3-7
2	Cutting copper and aluminum cable and crimping lug to them from 4mm ² to 25mm ² , cross section.	8-9
3	Connection and testing of fluorescent tube light, high pressure M.V. lamp, sodium vapor lamp, M.H lamp, CFL and latest model lamps – measure inductance, Lux/ lumens (intensity of illumination) in each case-prepare lux table .	10-22
4	Study battery charger and make charging of lead acid battery (record charging voltage, current and specific gravity).	23-29
5	Erection of residential building wiring by CTS and conduit wiring system using main two points and test installation by test lamp method and a meggar.	30-35
6	Fault finding & repairing of Fan – prepare an inventory list of parts.	36-39
7	Find out fault of D.C. generator, repair and test it to run.	40-43
8	Find out fault of D.C. motor starters and A.C motor starter – prepare an inventory list of parts used in different starters.	44-49
9	Dismantle, over haul and assemble a single phase induction motor. Test and run it. – prepare an inventory list.	50-52
10	Dismantle over haul and assemble a three phase squirrel cage and phase wound motor. Test and run them	53-57
11	Overhaul a single phase / 3 phase variac.	58-61

Experiment - 01

Aim- Identification of single core (SC), twin core (TC), three core (3C), four core (4C); copper and aluminum PVC, VIR & Weather Proof (WP) wire and prepare Britannia T- joint and Married Joint.

APPARATUS REQUIRED: -

Sl. No	Name of the Equipment	Specification	Quantity
1	Insulated Combination Plier	150mm	1no
2	Diagonal Cutting Plier	150mm	1no
3	Steel Rule	300mm	1no
4	Bench Vice	-	1no
5	Hack saw	-	1 no
6	Wooden Mallet	250gm	1no
7	Copper Wire	8 SWG	400 mm
8	Aluminum Wire	20 SWG	As Per Required
9	Multi-stand copper wire		1no
10	Electrician Knife	100mm	1 no
11	Cotton waste	-	As Per Required

Theory:-

Single Core Cable: -

Single core cable is a cylindrical strand of metal that has a single conductor. Single core cable is made up of aluminum or copper wire available in different thickness and gauges. Single-core is mainly used for domestic or residential purposes.

Twin Core Cable:-

This type of cable is used to connect small appliances which are double insulated and need no earth. The cable only has two cores being live and neutral. As this is flex cable it will be of circular shape with an outer sheath and two color coded

PVC insulated cores.

Three Core Cable:-

This type of cable is used to connect appliances such as lamps or extension cables to the power outlet sockets. The flex cable (flexible cord/cable) has three cores being Live, Earth and Neutral. Each of the cores is insulated with a layer of color coded PVC, all three cores are then surrounded by an additional outer PVC layer known as the sheath.

Four Core Cable:-

This type of cable is used for wiring two ways light switches. The cable consists of 4 cores with 1 being the neutral and the other three potentially being live depending on the way the lighting circuit is designed and what position the switches are in. Each of the cores (except the earth) is covered in a layer of color coded PVC insulation to allow identification; these cores are then covered in an outer layer of PVC known as the sheath.

Copper and Aluminum PVC Wire: -

These types of cables are mostly used in domestic purposes. These are available in both single core and multi strand. These types of wires are insulated by PVC (Polyvinyl chloride) material.

VIR Cables: -

A VIR (Vulcanized India Rubber) wire mainly consists of a tinned conductor having rubber coating. Tinning of conductor prevents the sticking of rubber to the conductor. Thickness of rubber mainly depends on the operating voltage to which wire is designed. A cotton barding is done over the rubber insulations to protect the conductor against the moisture. Finally the wire is finished with wax for cleanliness.

Weather Proof Cables:-

Weatherproof line wire consists of single conductor covered with either Linear Low-Density Polyethylene (LLDPE) or Cross-linked Polyethylene (XLPE). Conductors may be compressed or concentric strand of ACSR, AAC or solid, compressed or concentric strand copper.

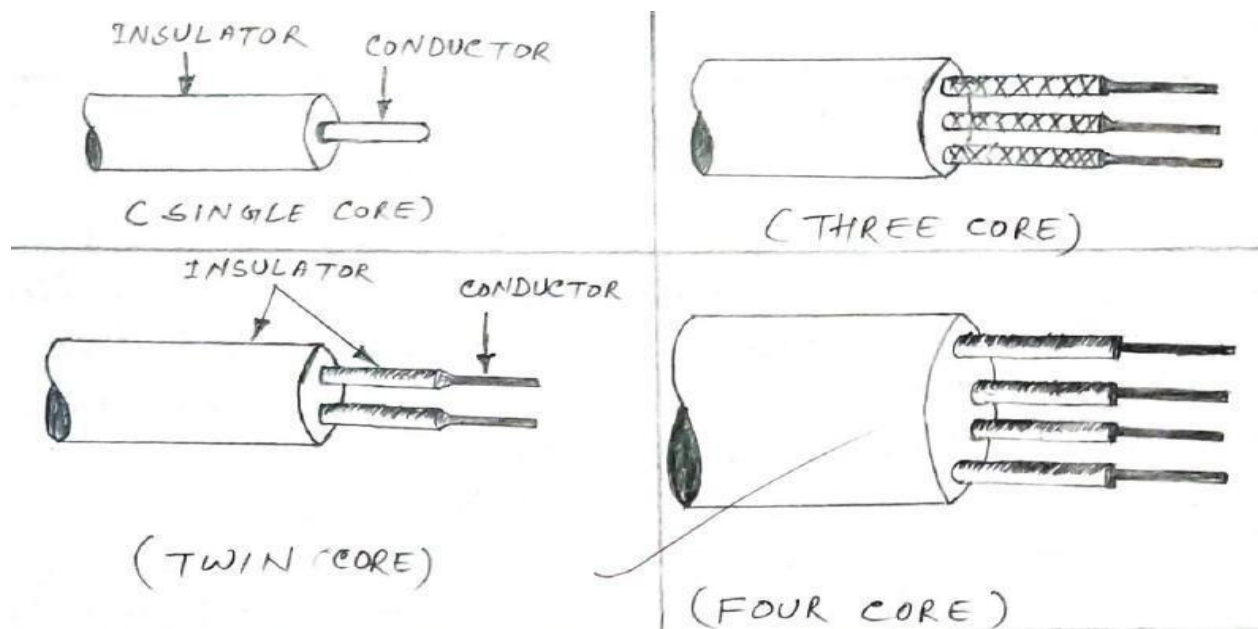

Britannia T Joint:-

- (i) Britannia T joint is a form of electrical joint used for bare overhead lines for tapping the electrical energy perpendicular to the service line.
- (ii) This joint is used where tapping is to be taken to place perpendicular or at an angle to the main overhead lines.
- (iii) The method of making Tee_ and straight joints is about the same as both the joints require binding wire.

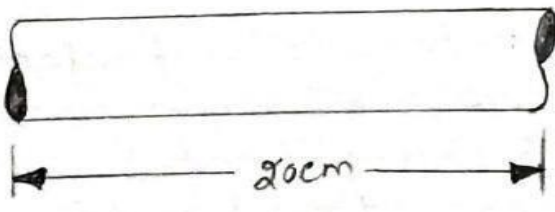
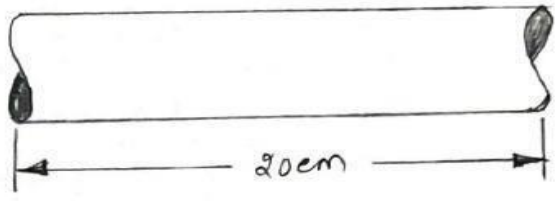

(Fig-1)

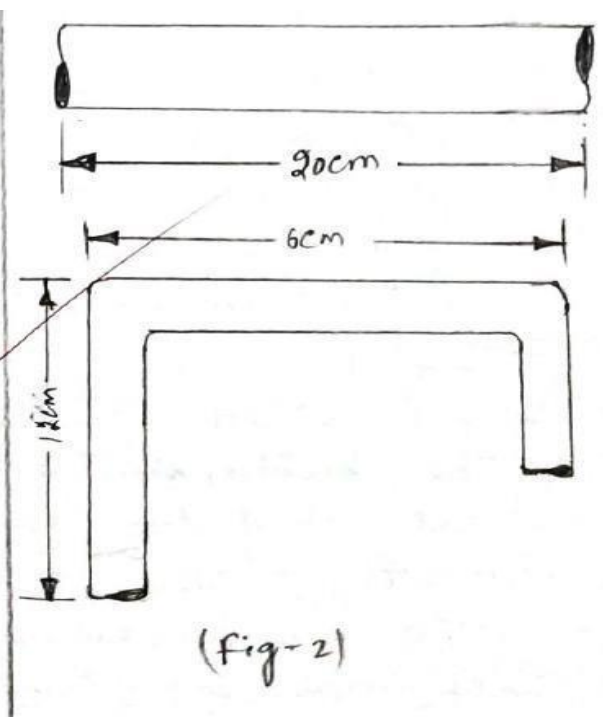

(fig-2)

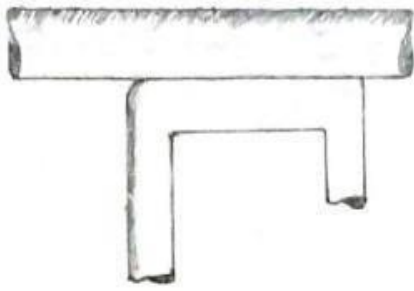

(Fig-3)

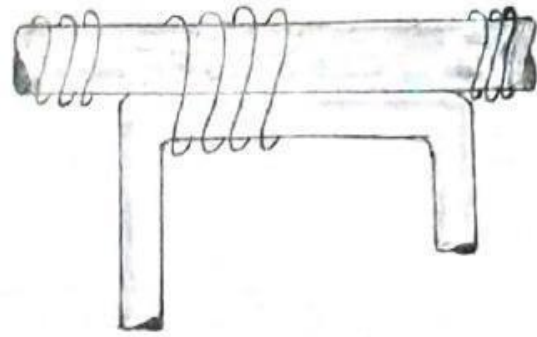

(Fig-4)

Married Joint:-

- (i) A married joint is a joint used for joining multi-stand cables.
- (ii) The wire_s stands are separated then inter placed with the wires of other cable and then twisted together before finally being soldered.
- (iii) It is used in places where appreciable electrical conductivity is required, along with compactness.

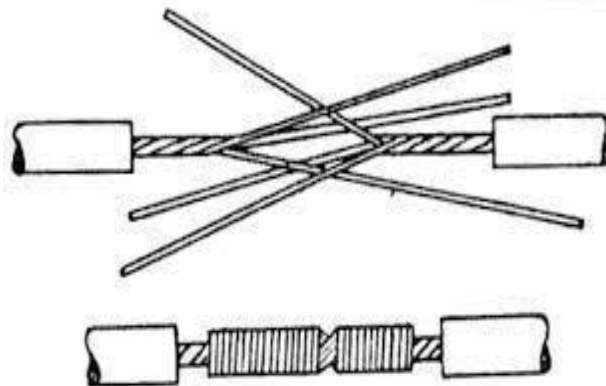
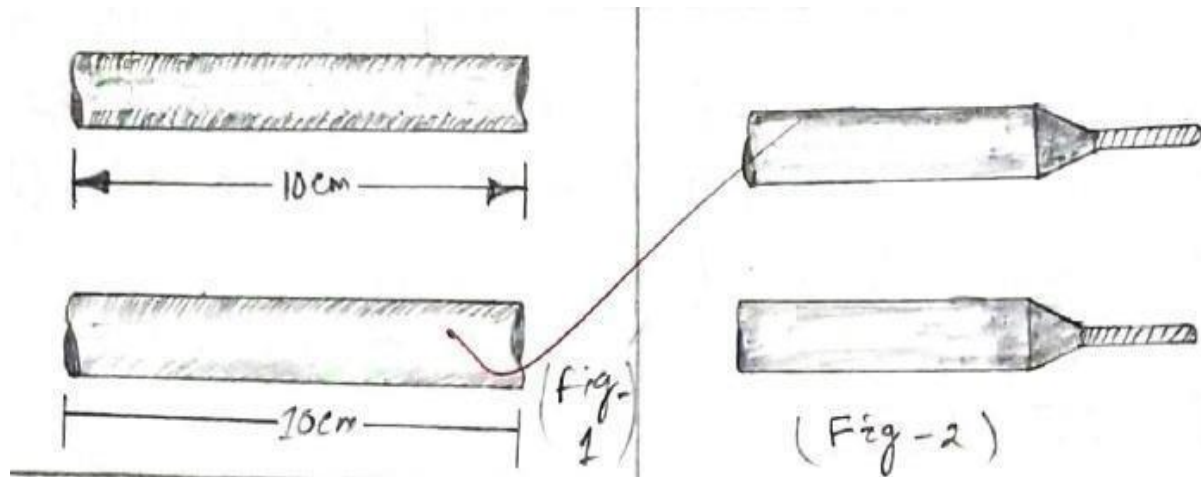

Procedure:-

Britannia T

Joint: -

- (i) Conductor should be straight with the help of wooden mallet.
- (ii) Mark the conductor as per figure.
- (iii) Then cut the conductor with the help of hack-saw, after that fixed on the vice and bend it as per marking at 90° .
- (iv) Binding the two conductors with the help of aluminum wire.
- (v) Binding should be tight and no gap between two conductor.

Married Joint: -

- (i) Mark the conductor as per figure with the help of steel rule and pencil.
- (ii) Then cut it with the help of diagonal cutting plier.
- (iii) Then remove the insulation with the help of electrician knife and cleaned the conductors.
- (iv) Then untwist the multi-stand conductors and joint them as per figure.

Conclusion:- From the above experiment , we learnt about the single core (SC), twin core (TC), three core (3C), four core (4C); copper and aluminum PVC, VIR & Weather Proof (WP) wire and Britannia T- joint and Married Joint.

Experiment - 02

Aim- Cutting copper and aluminum cable and crimping lug to them from 4mm² to 25mm², cross section.

APPARATUS REQUIRED: -

Sl. No	Name of the Equipment	Specification	Quantity
1	Insulated Combination Plier	150mm	1no
2	Diagonal Cutting Plier	150 mm	1no
3	Electrician Knife	100mm	1no
4	Crimping Tool	150mm	1no
5	Steel rule	300mm	1no
6	06 sq mm copper cable	150mm	1no
7	Lug	6 sq mm	1 no

Theory:-

Crimping

Tool-

A crimping tool is a device used to conjoin two pieces of metal by deforming one or both of them in a way that causes them to hold each other. The result of the tool's work is called a crimp. A good example of crimping is the process of affixing a connector to the end of a cable.

The tool is operated by squeezing the handles. The jaws move together, grip and then crimp the fitting. Using the crimping tool that matches the specific crimp lug will give the correct crimping force for a proper executed crimp. A properly executed crimp will indent the top of the lug.

If the terminal has too deep a crimp, the strength of the joint is reduced. With too shallow a crimp, the electrical contact has a high resistance. Selection of the correct crimping tool is essential.

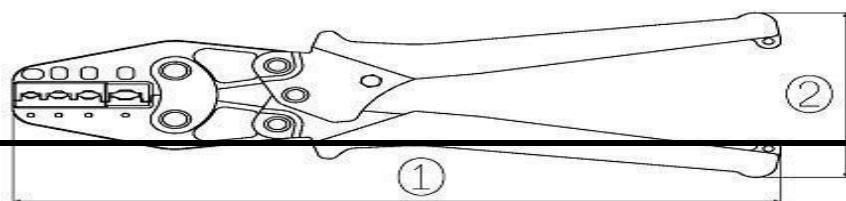

Lug: - The clamps or connectors used for connecting two electrical devices are called as electrical lugs. Use of cable lugs allows supply and distribution of electric current without any hindrance between electrical cables. Electrical lugs are used when permanent connection is not possible between devices or cables.

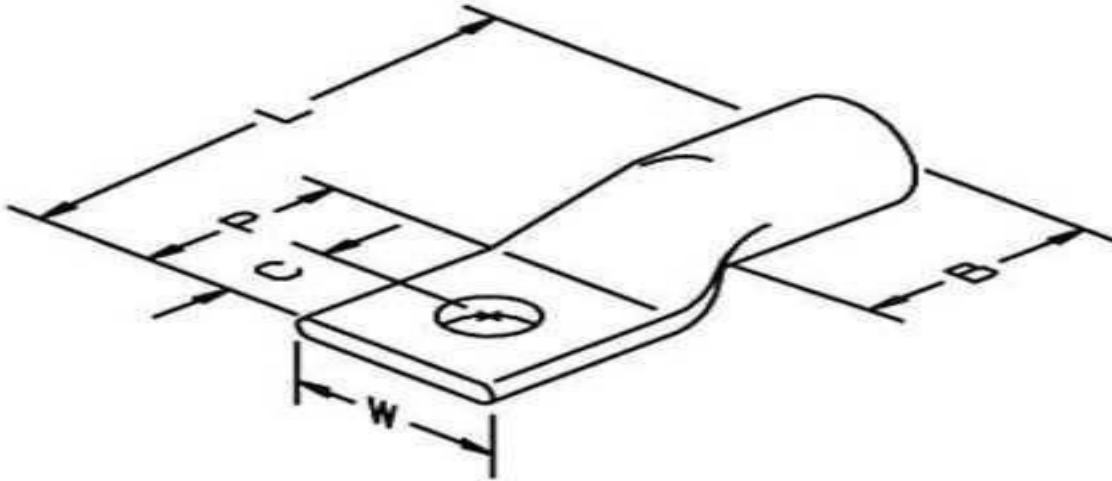

Procedure:-

- (i) We should take all the tools & instrument for this experiment.
- (ii) Remove the insulation of 10 sq mm copper wire up to 30mm with the help of wire stripper.
- (iii) Remove the insulation 25 sq mm HT cable up to 50mm with the help of electrician knife.
- (iv) Inset the lugs of each cable.
- (v) Crimp the lug with the help of hydraulic crimping tool.

Conclusion: - From the above experiment, we learn how to crimp lugs to on copper and aluminum cables.

Experiment - 03

Aim- Connection and testing of fluorescent tube light, high pressure M.V. lamp, sodium vapor lamp, M.H. lamp, CFL and latest model lamps – measure inductance, Lux/ lumens (intensity of illumination) in each case prepare lux table.

APPARATUS REQUIRED: -

Sl. No	Name of the Equipment	Specification	Quantity
1	Insulated Combination Plier	150mm	1no
2	Diagonal Cutting Plier	150 mm	1no
3	Fluorescent Tube Light	40W	1 no
4	HPMV Lamp	150 W	1no
5	HPSV Lamp	150 W	1 no
6	CFL Lamp	27 W	1 no
7	Neon Sign Lamp	-	1 no
8	LCR Meter	-	1 no
9	Lux Meter	-	1 no
10	Connecting Wires	-	As per required

Theory:-

Fluorescent Tube Light: -

A fluorescent lamp has changed over electrical energy into useful light energy to a great deal more proficiently than incandescent lamps. The normal luminous viability of fluorescent lighting frameworks is 50 to 100 lumens per watt, which is a few times the adequacy of incandescent lamps with equivalent light yield.

Fluorescent Tube: -

- (i) A fluorescent light bulb is basically a glass tube capped by two bases.
- (ii) These bases are fitted with pins to carry current to internal components called cathodes.
- (iii) The tube has filled with droplets of mercury and an inert gas.
- (iv) The inner surface of the tube is coated with a fluorescent powder or phosphor.

- (v) This phosphor emits light when exposed to ultra-violet rays.
- (vi) Cathodes or electrodes are made up of coiled tungsten filaments coated with a mixture of barium and strontium oxide.

Choke:-

- (i) The ballast is basically a coil of many turns wound on a laminated iron core.
- (ii) It steps up the supply voltage to start the fluorescent tube conducting.
- (iii) Once the tube is conducting, it regulates the flow of current to the tube cathodes to keep them from burning out.

Starters:-

- (i) A starter in the fluorescent tube circuit performs two functions. It is U shaped and made of bimetallic strips.
- (ii) It completes the circuit at first for preheating the electrodes.
- (iii) It opens the circuit to provide voltage kick for ignition.

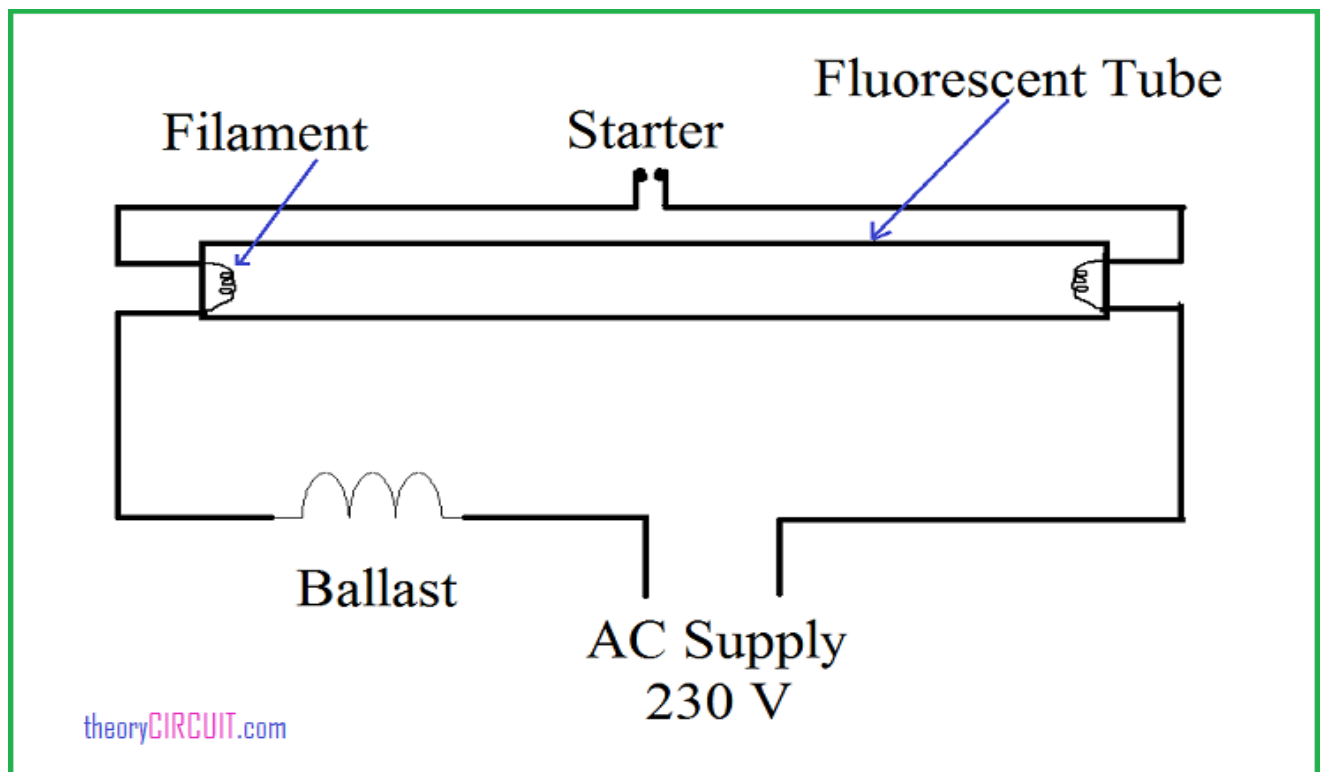

Working: -

- When we switch ON the supply, full voltage comes across the lamp and as well as across the starter through the ballast. But at that instant, no discharge happens, i.e., no lumen output from the lamp.

- At that full voltage first the glow discharge is established in the starter. This is because the electrodes gap in the neon bulb of starter is much lesser than that of the fluorescent lamp.
- Then gas inside the starter gets ionized due to this full voltage and heats the bimetallic strip. That causes to bend the bimetallic strip to connect to the fixed contact. Now,

current starts flowing through the starter. Although the ionization potential of the neon is more than that of the argon but still due to small electrode gap, a high voltage gradient appears in the neon bulb and hence glow discharge gets started first in the starter.

- As soon as the current starts flowing through the touched contacts of the neon bulb of the starter, the voltage across the neon bulb gets reduced since the current, causes a voltage drop across the inductor (ballast). At reduced or no voltage across the neon bulb of the starter, there will be no more gas discharge taking place and hence the bimetallic strip gets cool and breaks away from the fixed contact. At the time of breaking of the contacts in the neon bulb of the starter, the current gets interrupted, and hence at that moment, a large voltage surge comes across the inductor (ballast).

$$V = L \frac{di}{dt}$$

*Where, L is inductance of inductor
and $\frac{di}{dt}$ is rate of change of current.*

- This high valued surge voltage comes across the fluorescent lamp (tube light) electrodes and strikes penning mixture (mixture argon gas and mercury vapor).
- Gas discharge process gets started and continues and hence current again gets a path to flow through the fluorescent lamp tube (tube light) itself. During discharging of penning gas mixture the resistance offered by the gas is lower than the resistance of starter.
- The discharge of mercury atoms produces ultraviolet radiation which in turn excites the phosphor powder coating to radiate visible light.

- Starter gets inactive during glowing of fluorescent lamp (tube light) because no current passes through the starter in that condition.

Physics of behind Fluorescent Lamp: -

When a sufficiently high voltage is applied across the electrodes, a strong electric field is set up. A small amount of current through the electrodes filaments heats up the filament coil. As the filament is oxide coated, a sufficient amount of electrons is produced, and they rush from the negative electrode or cathode to the positive electrode or anode due to this strong electric field.

During the movement of free electrons, the discharge process gets established. The basic discharge process always follows three steps:

1. Free electrons are derived from the electrodes, and they get accelerated by the electric field applied.
2. Kinetic energy of the free electrons is converted into the excitation energy of the gas atoms.
3. The excitation energy of the gas atoms gets converted into the radiation.

In the discharge process, a single ultra violet spectral line of 253.7 nm is produced at a low pressure of mercury vapor. To generate 253.7 nm ultra violet ray the bulb temperature is kept

between 105 to 115°F.

The length to diameter ratio of the tube should be such that fixed wattage loss happens at both ends. Where this wattage loss or glow of electrodes takes place is called cathode and anode fall region. This watt loss is very small.

Again the cathodes should be oxide coated. Hot cathode provides an abundance of free electrons. Hot cathodes, mean those electrodes which are heated by circulating current and this circulating current is provided by choke or control gear. Few lamps have cold cathode also. Cold cathodes have a larger effective area and higher voltage such as 11 kv is applied across them to get ions. Gas starts to be discharged due to this high voltage application. But at 100 to 200 V the cathode glow get separated from the cathode, it is called cathode fall. This provides a large supply of ions which are accelerated to the anode to produce secondary electrons on impact which in term produce more ions. But cathode-fall in hot cathode discharge is only at 10 V.

High Pressure Mercury Vapor (HPMV) Lamp: -

A mercury vapour lamp is a high-pressure, electric arc discharge lamp that provides intense illumination over a selected range of wavelengths. Lamps that emit light by the passage of electric current through a gas are called gas-discharge lamps. These lamps were first introduced during the 1930s.

In case of fluorescent lamp the mercury vapor pressure is maintained at lower level such that 60% of the total input energy gets converted into 253.7 nm single line. Again transition of the electrons requires least amount of input energy from a colliding electron. As pressure increases the chance of multiple collisions gets increased. A schematic diagram of mercury lamp is shown below. This lamp is

containing an inner quartz arc tube and outer borosilicate glass envelope.

The quartz tube is able to withstand arc temperature 1300K, whereas the outer tube withstands only 700K.

Between two tubes nitrogen gas is filled to provide thermal insulation. This insulation is for to protect the metal parts from oxidation due to higher arc temperature. The arc tube contains the mercury and argon gas. Its operational function is same as the fluorescent lamp. Two main electrodes and a starting electrode are inside the arc tube. Each main electrode holds a tungsten rod upon which a double layer of coiled tungsten wire is wound. Basically the electrodes are dipped into a mixture of thorium, calcium and barium carbonates.

They are heated to convert these compounds into oxides after dipping. Thus they get thermally and chemically stable to produce electrons. The electrodes are connected through a quartz tube by molybdenum foil leads.

Just when the main supply voltage is applied to the mercury lamp, this voltage comes across the starting electrode and the adjacent main electrode (bottom electrode) as well as across two

main electrodes (bottom and top electrodes). As the gap between starting electrode and bottom main electrode is small the voltage gradient is high in this gap.

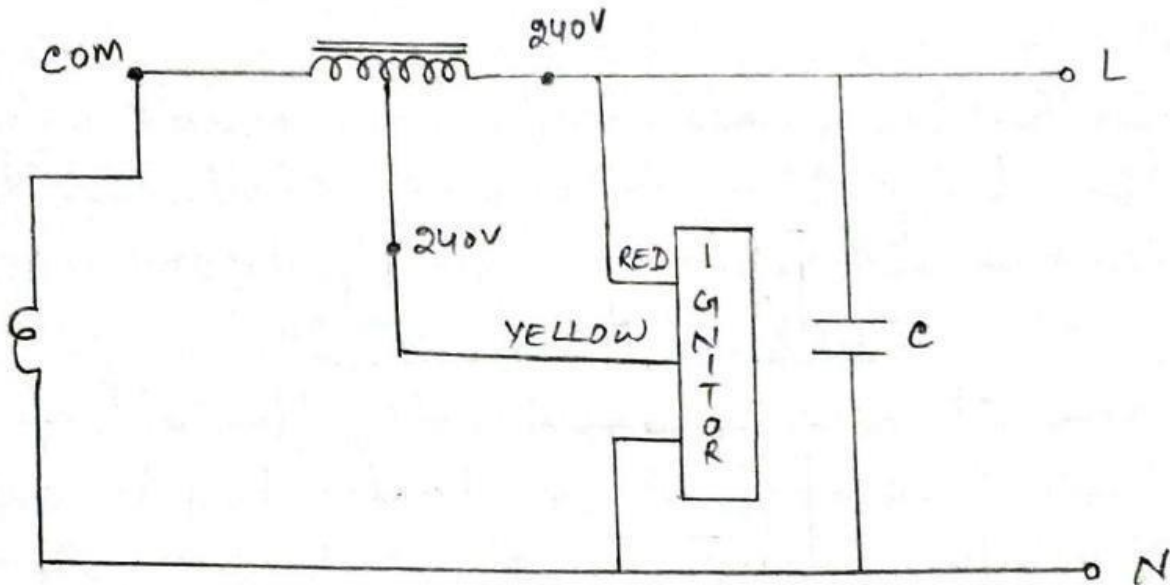
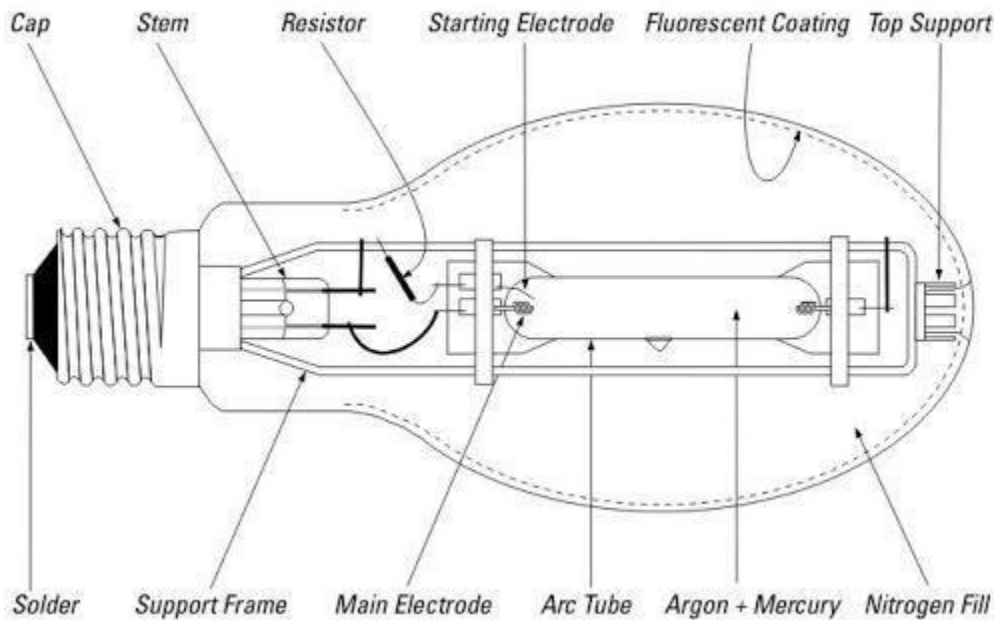

[Circuit Diagram of HPMV Lamp]

Because of this high voltage gradient across the starting electrode and the adjacent main electrode (bottom), a local argon arc is created, but the current gets limited by using a starting resistor.

This initial arc heats up the mercury and vaporizes it and this mercury vapor helps

to strike the main arc soon. But the resistance for the main arc current control resistor is somewhat less than the resistance of the resistor used in the initial arc current control purpose. For this reason initial arc stops and main arc continues to operate. It takes 5 to 7 minutes to make all of the mercury to be vaporized completely. The lamp gets its state of its operational stability. The mercury

vapor arc gives visible spectra of green, yellow and violet. But there may be still some invisible ultraviolet radiation during discharging process of mercury vapor so phosphor coating may be provided on outer glass cover to improve efficiency of the mercury lamp.

High Pressure Sodium Vapor (HPSV) Lamp: -

High-pressure sodium lamps (also known as HPS Lamps or HPS lights) are a type of sodium lamp that is widely used in industrial lighting and many public outdoor areas. They are commonly used in public parking lots, roadways, and other security areas.

A big driver behind their use is their high efficiency – around 100 lumens per Watt (when measured for photonic lighting conditions) some higher-power lamps (>600 Watt) can achieve efficacies of around 150 lumens per watt.

It is very difficult to get any material which is free from corrosion in presence of sodium vapor in high temperature and pressure. This is the main difficulty of producing high-pressure sodium lamp.

In 1959, the development of polycrystalline alumina (PCA) opened a new path to introduce the high-pressure sodium vapor Lamp, as this material is very rarely affected by high pressure and temperature sodium vapor. The first lamp with 400 W, 42000 initial lumens and 6000-hour life first came in the market in 1965. But afterward, some improvements made this lamp with 50000 initial lumens with 24000 hours at 10 hours per start. We can get a lamp that has 2.4 times the lumens output of its mercury counterpart with same rated life span.

It has an inner PCA arc tube that is filled with xenon gas. This xenon gas is used for starting purpose of the lamp as ionization potential of xenon gas is lowest among all other inert gases used for this purpose. In addition to xenon gas sodium mercury amalgam is present in this arc tube, too. In each end, back wound and coated tungsten electrodes are mounted. To seal the tube monolithic seal is used instead of niobium end cap.

The arc tube is inserted into a heat resistant outer bulb. It is supported by an end clamp that is floating. This end clamp permits the entire structure to expand and contract without distorting.

The space between the tube and the bulb is a vacuum space. This vacuum space is needed to insulate heat from the arc tube because it is necessary to keep the arc tube at required temperature to sustain arc during normal operation. High pressure sodium lamp has very small diameter ($3/8$ inch). So there is not enough space to provide any starting electrode in the arc tube. So a higher voltage is required to initiate the arc. Ballast with igniter is used for this purpose. High voltage is fed to the lamp from the ballast by using the phenomenon of superimposing a low energy high voltage pulse.

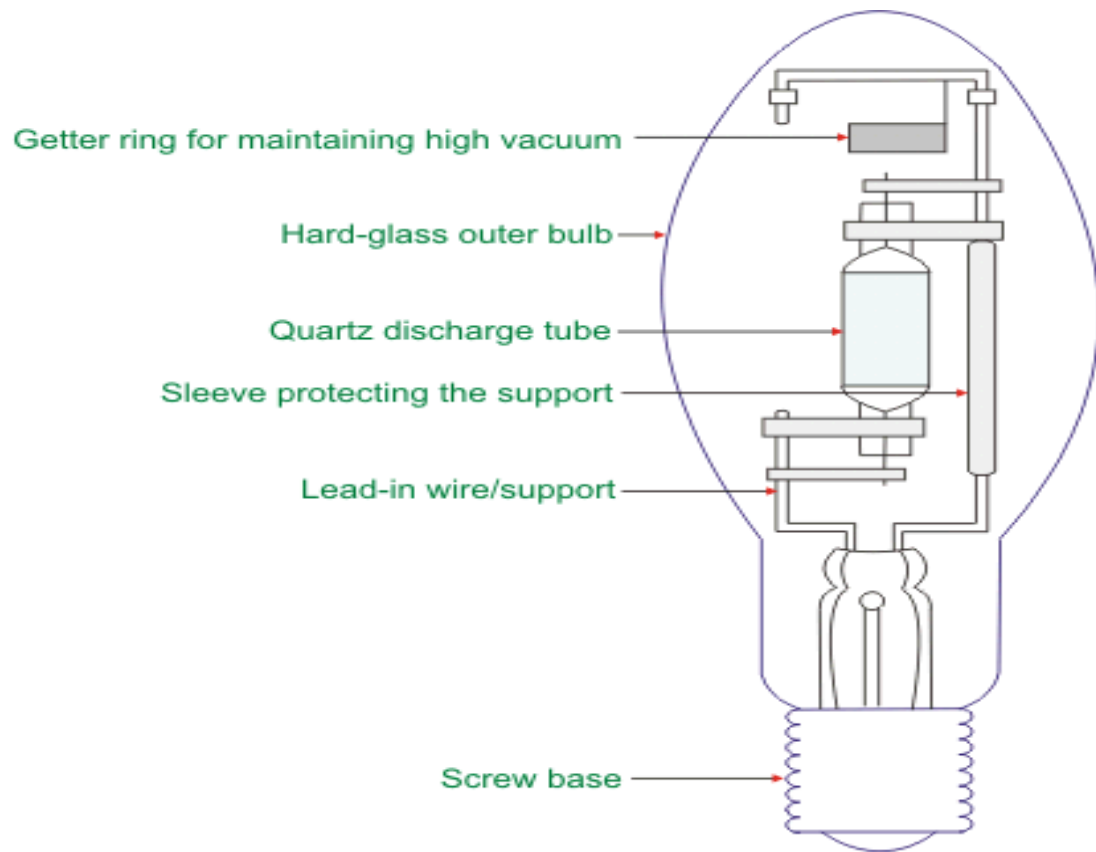

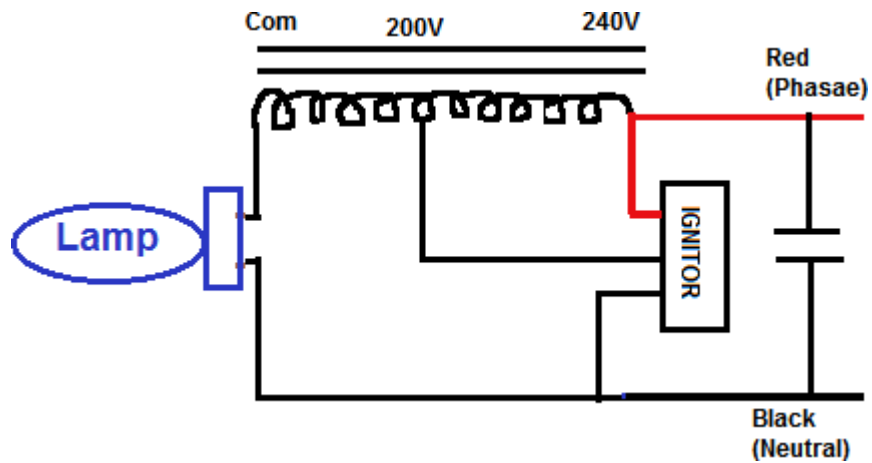

[Circuit Diagram of HPSV Lamp]

Generally a typical pulse has a peak voltage of 2500V and it has durability for only 1 microsecond only. This high voltage pulse makes the xenon gas ionized sufficiently. Then it

initiates and maintains the xenon arc. The initial arc has sky blue color. Amalgam used in the reservoir formed inside the arc tube. It is in the back of one of the electrodes. It is normally vaporized during lamp operation. As the xenon arc has started temperature of arc tube is increased which first vaporizes mercury and the lamp start glowing with bluish white color. This color represents the effect of the xenon and mercury mixture at excitation. Gradually the temperature again rises, and sodium becomes vaporized lastly and becomes excited, a low pressure monochromatic yellow sodium spectrum results. During the period of sodium spectral line becomes at 589 nm. With temperature the sodium pressure increases from 0.02 atm in the monochromatic discharge to over 1 atm in the final steady state, broad spectrum condition. Also presence of excited mercury and xenon gives bluish effect to the lamp radiation and finally pleasant golden bright light comes out.

These lamps have high luminous efficacy and life span is about 24000 hours. It has excellent lumen maintenance capability.

M.H (Metal-Halide) Lamp: -

Metal halide lamp is special type of arc discharge lamp that works on the arc stream via some iodide salts along with argon gas and mercury vapor pressure at several millimeters with the arc tube temperature of 1000 K.

Constructional Feature: -

Metal halide lamp consists of

1. Glass bulb
2. Arc tube

3. Electrodes
4. Auxiliary electrode with high resistance
5. Glass stem
6. Molybdenum wire
7. Argon gas
8. Mercury vapor
9. Indium, thallium and sodium iodides

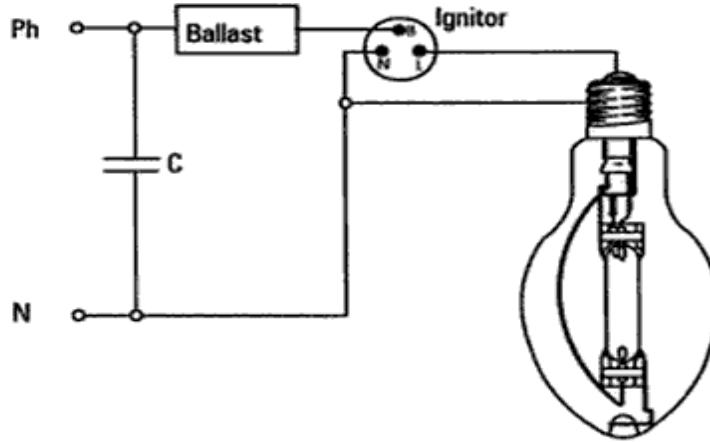
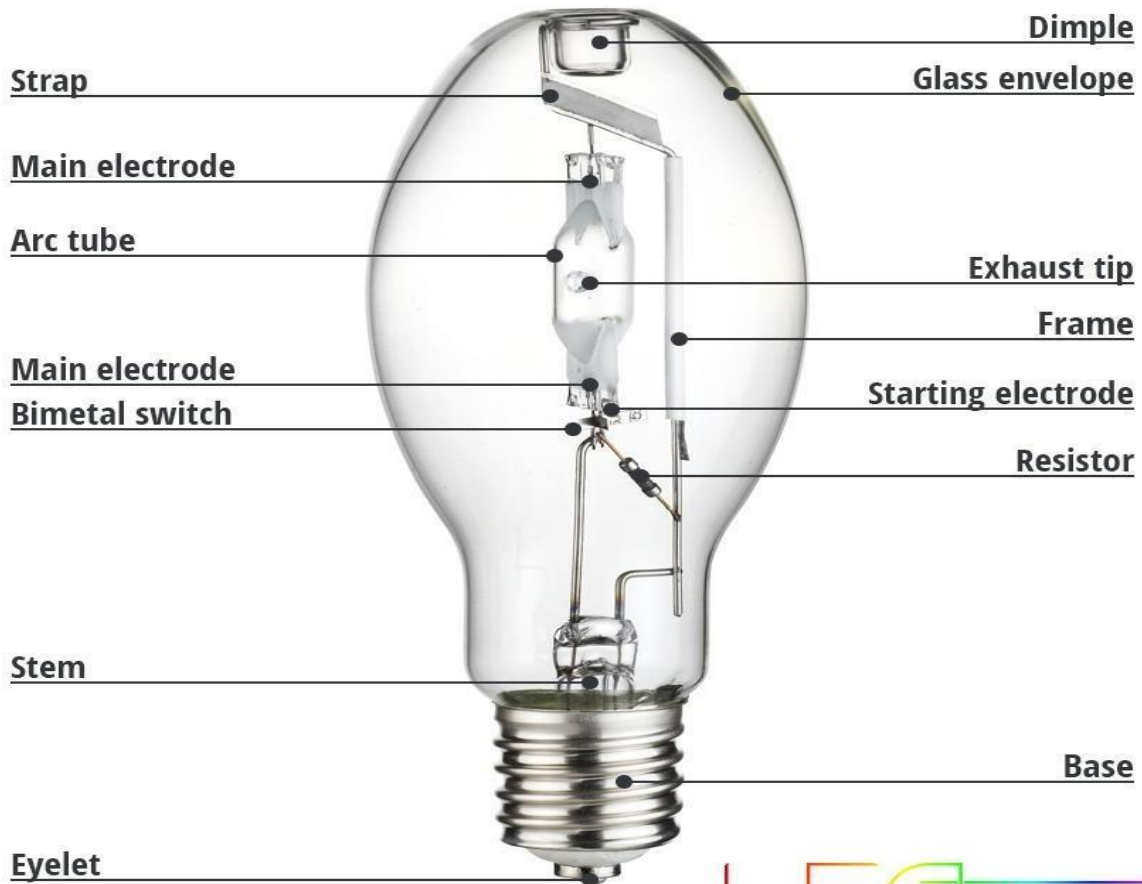

Figure 2 Metal halide lamp circuit

METAL HALIDE BULB STRUCTURE



LEEWATCHER.COM

How does a Metal Halide Lamp Work?

- When full voltage is applied across the main electrodes, no arc is produced at the time of switching.
- The auxiliary electrode or starter electrode near the main electrodes attached to the glass stem creates initial discharge between them.
- A bimetal switch is there to short the starter electrode to the main electrode just at the time of starting.
- Starter electrode is used to create initial arc between main and auxiliary electrode that heats up the metal halide salts.
- Starter electrode or auxiliary electrode is of high resistance to limit the current at initial arc.
- Again discharge is first in argon and then in mercury.
- Small amount of mercury vapor helps to establish main arc formation between main electrodes through metal halides vapor one by one.
- To reach up to full light output this lamp takes 5 minutes.

CFL (Compact Florescent Lamp): -

- (i) The compact fluorescent light bulb or lamp is a type of fluorescent lamp generally designed as a replacement for incandescent or halogen lamps. There are two major types of compact fluorescent lamp, screw-in and plug-in.
- (ii) Screw in lamps are self-ballasted and can generally be placed in an existing screw socket without any additional equipment, plug-in bulbs require a ballast and a socket that corresponds to their specific base configuration. These are also sometimes referred to as integrated (screw base) and non-integrated (plugbase).
- (iii) Both come in a wide variety of wattages, sizes, color temperatures, and base types, and they are known primarily for their efficiency, long life, low cost, and ease of upgrading.

Working:-

- (i) Compact fluorescent lamps are functionally identical to linear fluorescent bulbs.
- (ii) Both are gas-discharge lamps that use electricity emitted from cathodes to excite mercury vapor contained within the glass envelope, using a process known as inelastic scattering.
- (iii) Phosphors and a noble gas such as argon are also contained within the glass envelope.
- (iv) The mercury atoms produce ultraviolet (UV) light, which in turn causes the phosphors in the lamp to fluoresce or glow, producing visible light.

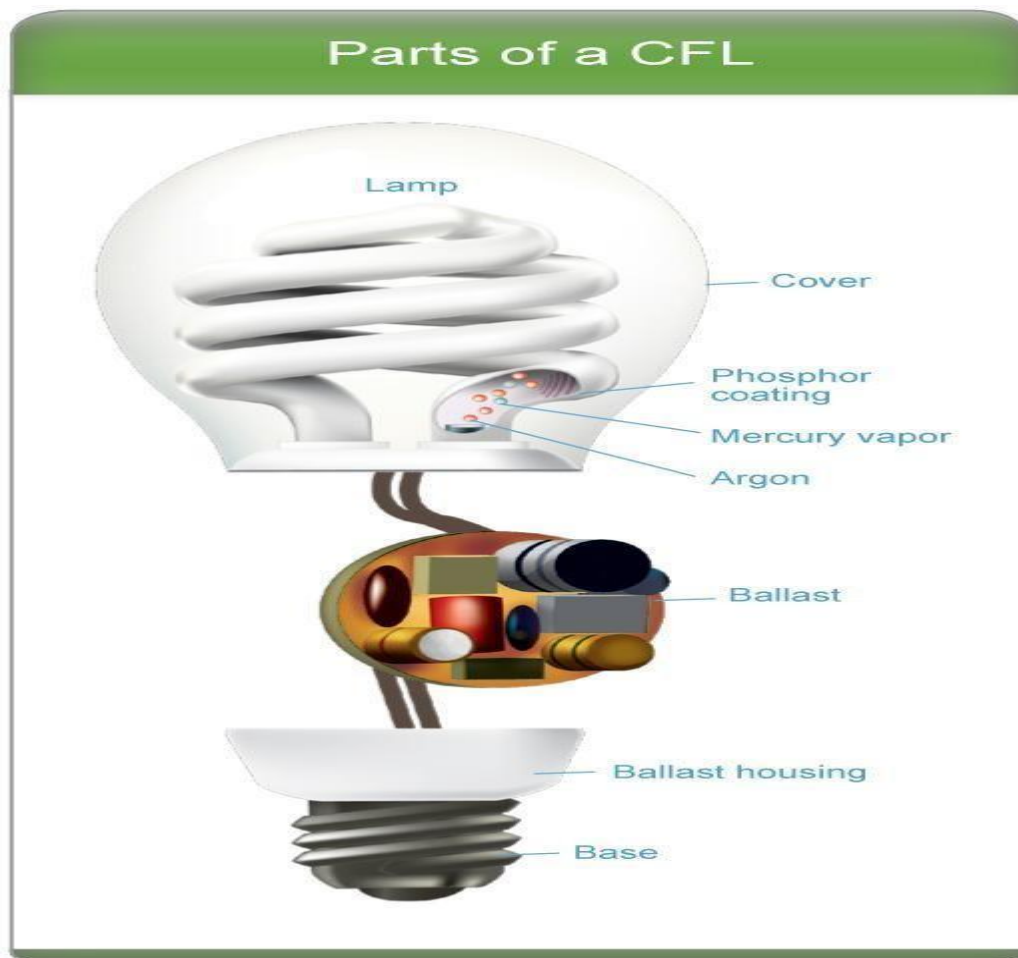

Latest Model

Lamp:- Neon Sign

Lamp:-

- The neon sign lamp is a low pressure gas discharge lamp. It is a cold cathode fluorescent lamp (CCFL).
- A neon light contains a tiny amount of neon gas under low pressure.
- Electricity provides energy to strip electrons away from neon atoms, ionizing them. Ions are attracted to terminals of the lamp, completing the electric circuit.
- Light is produced when neon atoms gain enough energy to become excited. When an atom returns to a lower energy state, it releases a photon (light).

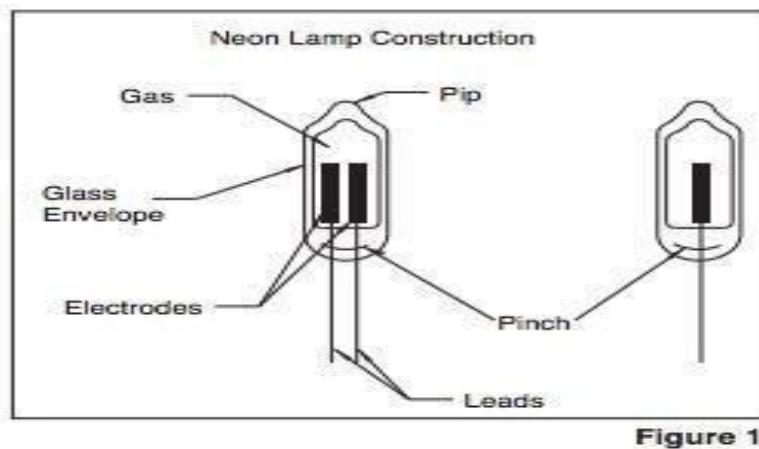

Working: -

1. A neon lamp is a sealed glass tube filled with neon gas, which is one of the so-called "noble" (inert or un-reactive) gases on the far right of the Periodic Table. (There are minute quantities of neon in the air around us: take a deep breath and you'll breathe in a volume of neon as big as an orange pip!)
2. There are electrical terminals at either end of a neon tube. At one end, there's a negative terminal ("-ve", shown blue); at the other end there's a positive terminal ("+ve", shown green).
3. When the tube is switched off, it contains ordinary atoms of neon gas (brown circles).
4. Rig the terminals up to a high-voltage power supply (about 15,000 volts—because you need a lot of "electrical force" to make things happen) and switch on, and you'll literally start pulling the neon atoms apart. Some of the atoms will lose electrons to become positively charged ions (big green dots). Being positively charged, these neon ions will tend to move toward the negative electrical terminal.
5. The electrons the neon atoms lose (small blue dots) are negatively charged, so they hurtle the opposite way toward the positive terminal at the other end of the tube.

6. In all this rushing about, atoms, ions, and electrons are constantly colliding with one another. Those collisions generate a sudden smash of energy that excites the atoms and ions and makes them give off photons of redlight.
7. So many collisions happen with such rapidity that you get a constant buzzing of red light from the tube. You also get quite a lot of energy given off as heat. If you've ever stood near a neon light, you'll know they can get very hot. That's because the atoms are giving off quite a bit of invisible infrared radiation (in other words, heat) as well as visible radiation (better known as red light).

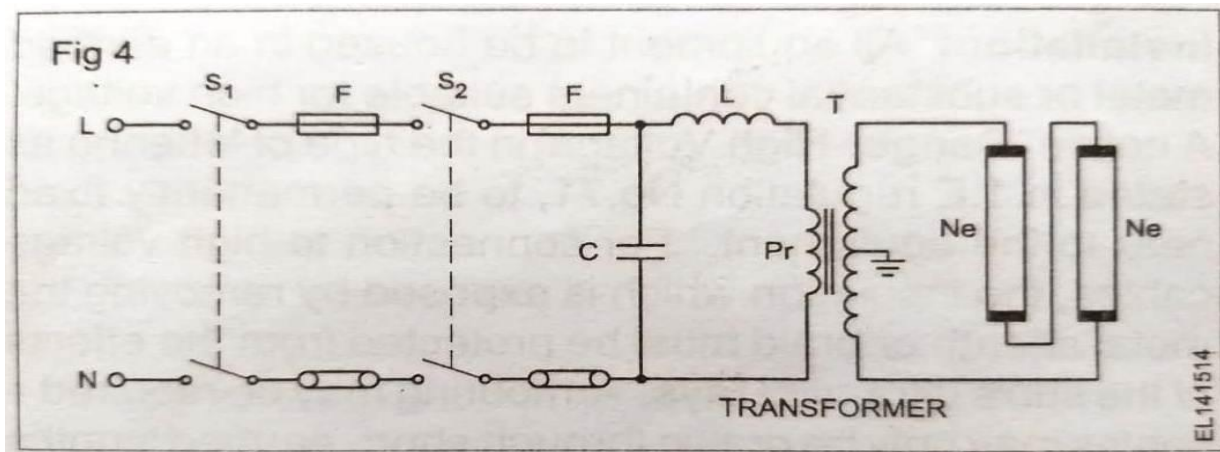

[Circuit Diagram of Neon Lamp]

Procedure:-

1. Take all the lamps to the working table.
2. Connect all the lamps according to the circuit diagram.
3. Switch on the supply.
4. Measure the inductance with the help of LCR Meter and note it
5. Measure the luminous intensity with the help of Lux meter and note it.

6. Tabulation:-

Sl. No	Name of Lamps	Inductance In Henry
1	Fluorescent Tube Light	
2	HPMV Lamp	
3	HPSV Lamp	
4	M. H. Lamp	
Sl. No	Name of Lamps	Lux/ Lumen
1	Fluorescent Tube Light	
2	HPMV Lamp	
3	HPSV Lamp	
4	M. H. Lamp	
5	CFL	
6	Neon Sign Lamp	

Conclusion: - From the above experiment, we learnt about the Connection and testing of fluorescent tube light, high pressure M.V. lamp, sodium vapor lamp, M.H. lamp, CFL and Neon sign lamp.

Experiment - 04

Aim- Study battery charger and make charging of lead acid battery (record charging voltage, current and specific gravity).

APPARATUS REQUIRED: -

Sl. No	Name of the Equipment	Specification	Quantity
1	Lead acid Battery	150 Ah	1no
2	Battery Charger	12V/2A	1 no
3	Ammeter	0-5A DC	1 no
4	Voltmeter	0-24V DC	1no
5	Hydrometer	-	1no
6	Connecting Wires	-	As per required

Theory:

-

Battery

:-

A battery is a device consisting of one or more electro chemical cell with external connection for powering electrical devices. A battery generally consists of an anode, a cathode, and an electrolyte.

Lead Acid Battery:-

The battery which uses sponge lead and lead peroxide for the conversion of the chemical energy into electrical power, such type of battery is called a lead acid battery. The lead acid battery is most commonly used in the power stations and substations because it has higher cell voltage and lower cost.

Construction of Lead Acid Battery: -

The various parts of the lead acid battery are shown below. The container and the plates are the main part of the lead acid battery. The container stores chemical energy which is converted into electrical energy by the help of the plates.

1. Container – The container of the lead acid battery is made of glass, lead lined wood, ebonite, the hard rubber or bituminous compound, ceramic materials or moulded plastics and are seated at the top to avoid the discharge of electrolyte. At the bottom of the container, there are four ribs, on two of them rest the positive plate and the others support the negative plates.

The prism serves as the support for the plates and at the same time protect them from a short- circuit. The material of which the battery containers are made should be resistant to sulfuric acid, should not deform or porous, or contain impurities which damage the electrolyte.

2. Plate – The plate of the lead-acid cell is of diverse design and they all consist some form of a grid which is made up of lead and the active material. The grid is essential for conducting

the electric current and for distributing the current equally on the active material. If the current is not uniformly distributed, then the active material will loosen and fall out.

The grids are made up of an alloy of lead and antimony. These are usually made with the transverse rib that crosses the plates at a right angle or diagonally. The grid for the positive and negative plates are of the same design, but the grids for the negative plates are made lighter because they are not as essential for the uniform

conduction of the current.

The plates of the battery are of two types. They are the formed plates or plante plates and pasted or Faure plates.

Plante_splatesare used largely for stationary batteriesastheseare heavier inweight andmore costly than the pasted plates. But the plates are more durable and less liable to lose active material by rapid charging and discharging. The plantes plate has low capacity weight-ratio.

Faure process is much suitable for manufacturing of negative plates rather than positive plates. The negative active material is quite tough, and it undergoes a comparatively low change from charging and discharging.

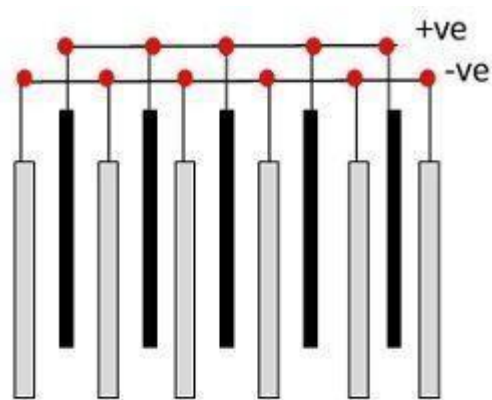

Arrangements of Plates in a Lead-acid-Battery

Circuit Globe

3. Active Material – The material in a cell which takes active participation in a chemical reaction (absorption or evolution of electrical energy) during charging or discharging is called the active material of the cell. The active elements of the lead acid are

- (i) **Lead peroxide (PbO_2)** – It forms the positive active material. The PbO_2 are dark chocolate brown in color.
- (ii) **Sponge lead** – Its form the negative active material. It is grey in color.
- (iii) **Dilute Sulfuric Acid (H_2SO_4)** – It is used as an electrolyte. It contains 31% of sulfuric acid.

The lead peroxide and sponge lead, which form the negative and positive active materials have the little mechanical strength and therefore can be used alone.

4. Separators – The separators are thin sheets of non-conducting material made up of chemically treated leadwood, porous rubbers, or mat of glass fiber and are placed between the positive and negative to insulate them from each other. Separators are grooved vertically on one side and are smooth on the other side.

5. Battery Terminals – A battery has two terminals the positive and the negative. The positive terminal with a diameter of 17.5 mm at the top is slightly larger than the negative terminal which is 16 mm in diameter.

Working Principle of Lead Acid Battery:-

When the sulfuric acid dissolves, its molecules break up into positive hydrogen ions (2H^+) and sulphate negative ions (SO_4^-) and move freely. If the two electrodes are immersed in solutions and connected to DC supply then the hydrogen ions

being positively charged and moved towards the electrodes and connected to the negative terminal of the supply. The SO_4^- ions being negatively charged moved towards the electrodes connected to the positive terminal of the supply main (i.e., anode).

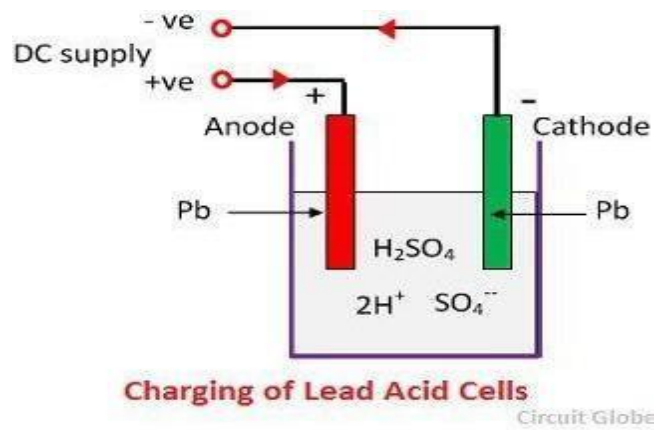

Each hydrogen ion takes one electron from the cathode, and each sulphates ions takes the two negative ions from the anodes and react with water and form sulfuric and hydrogen acid.

The oxygen, which produced from the above equation react with lead oxide and form lead peroxide (PbO_2 .) Thus, during charging the lead cathode remain as lead, but lead anode gets converted into lead peroxide, chocolate in colour.

If the DC source of supply is disconnected and if the voltmeter connects between the electrodes, it will show the potential difference between them. If wire connects the electrodes, then current will flow from the positive plate to the negative plate through external circuit i.e. the cell is capable of supplying electrical energy.

Chemical Action During Discharging:-

When the cell is full discharge, then the anode is of lead peroxide (PbO_2) and a cathode is of metallic sponge lead (Pb). When the electrodes are connected through a resistance, the cell discharge and electrons flow in a direction opposite to that during charging.

The hydrogen ions move to the anode and reaching the anodes receive one electron from the anode and become hydrogen atom. The hydrogen atom comes in contacts with a PbO_2 , so it attacks and forms lead sulphate (PbSO_4), whitish in colour and water according to the chemical equation.

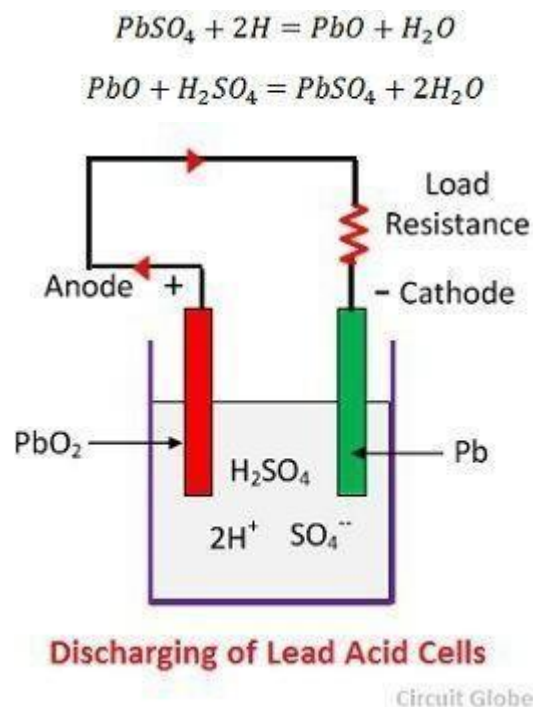

T

Each sulphate ion (SO_4^{2-}) moves towards the cathode and reaching there gives up two electrons becomes radical $\text{SO}_4^{\cdot -}$, attack the metallic lead cathode and form lead sulphate whitish in colour according to the chemical equation.

Chemical Action During Recharging:-

For recharging, the anode and cathode are connected to the positive and the negative terminal of the DC supply mains. The molecules of the sulfuric acid break up into ions of 2H^+ and SO_4^{2-} . The hydrogen ions being positively charged moved towards the cathodes and receive two electrons from there and form a hydrogen atom. The hydrogen atom reacts with lead sulphate cathode forming lead and sulfuric acid according to the chemical equation.

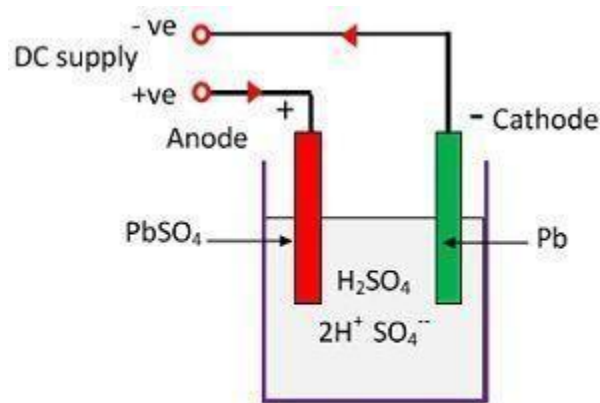
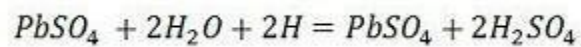

Recharging of Lead Acid Cell

Circuit Globe

SO_4^{2-} ion moves to the anode, gives up its two additional electrons becomes radical $\text{SO}_4^{\cdot -}$, react with the lead sulphate anode and form leads peroxide and lead sulphuric acid according to the chemical equation.

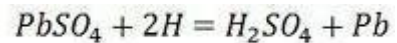

The charging and discharging are represented by a single reversible equation

given below.

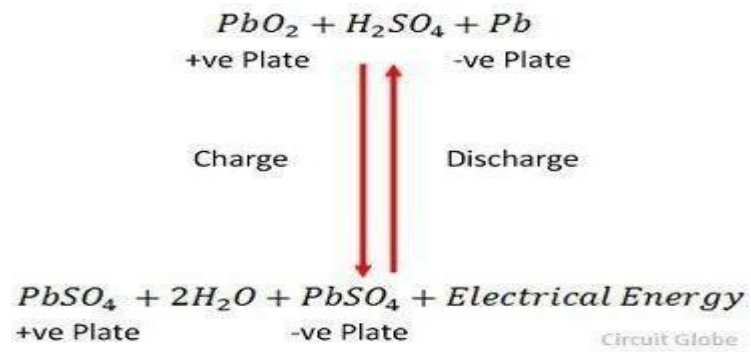

The equation should read downward for discharge and upward for recharge.

Necessity of Charging: -

- (i) During discharge, due to chemical reaction, the active electrodes become smaller and the internal resistance becomes smaller and the internal resistance becomes high, which cause low output.
- (ii) By reverse the action, send a current (DC) through the battery or cell in the opposite direction to that of the discharge.
- (iii) This process is called charging and the charging can be done through a battery charger.

Battery Charger:-

A battery charger is generally made of diodes which are connected in the form of bridge; a filter circuit which filters pulsating DC to pure DC and a transformer which step down ac voltages and also a voltmeter, a ammeter and a switch is connected.

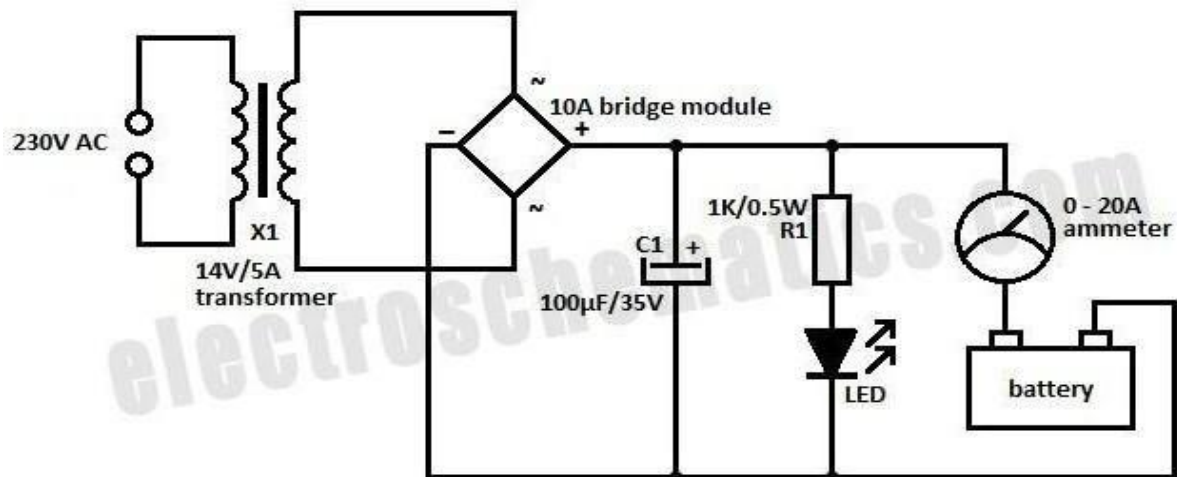

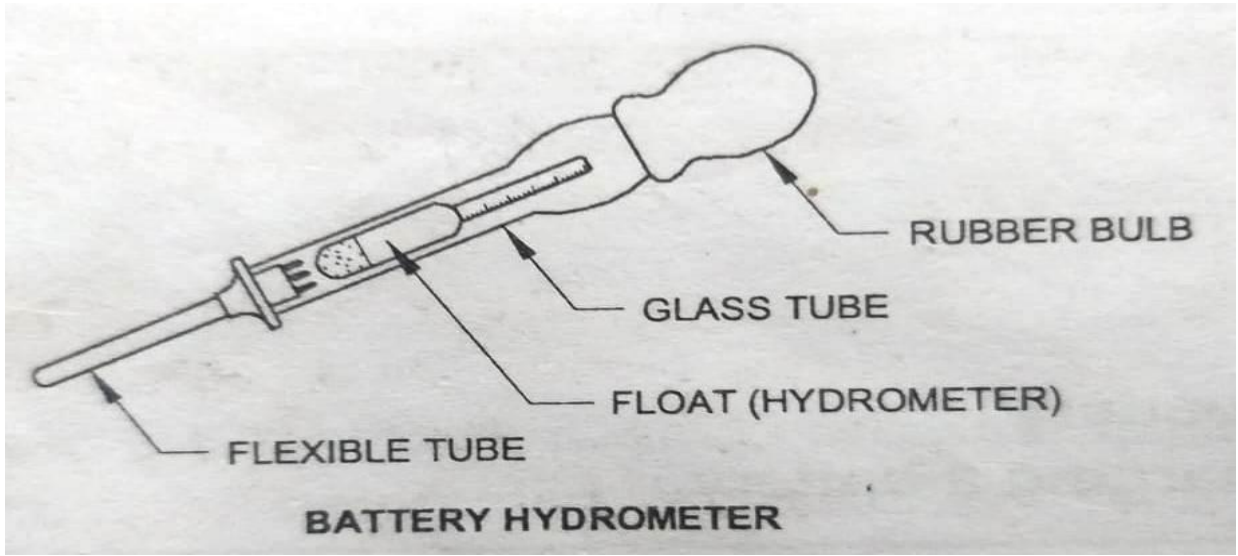

Procedure:-

1. Take the lead acid battery.
2. Unscrew all the cap of lead acid battery.
3. Measure the specific gravity with the help of hydrometer and note it.
4. Charge the battery with the help of battery charger.
5. Measure the charging current and voltage with the help of ammeter and voltmeter.
6. After full charge measure specific gravity and note it.

Tabulation:-

Sl. No	Cell Condition	Hydrometer Reading
1	Discharge	
2	50% Charge	
3	Full Charge	

Conclusion: - From the above experiment, we learnt about the battery charger and charging of lead acid battery.

Experiment - 05

Aim- Erection of residential building wiring by CTS and conduit wiring system using main two points and test installation by test lamp method and a megger.

APPARATUS REQUIRED:-

Sl. No	Name of the Equipment	Specification	Quantity
1	Conduit Pipe	½ Inch	2 nos
2	Insulated Combination Pliers	150mm	1no
3	Screw driver	200mm	1no
4	Line Tester	1100v, 6__	1no
5	Switch	6A,220V	2 nos
6	Lamp	100W, 230V	3 nos
7	Megger	500 V	1 no
8	Hammer	250gm	1 no
9	ICDP Main Switch	6A, 250V	1no
10	Switch Board	4 X 4	4 nos
11	Drill Machine	-	1 no
12	Angle Holder	6A, 250V	2 nos
13	Connecting Wires	1.0 sq mm	As Per Required

Theory: -

CTS

Wiring: -

- i. The full form of CTS wiring is cab tyre sheath wiring.
- ii. Single core or double core or three core CTS cables with a circular oval shape cables are used in this kind of wiring. Mostly, single core cables are preferred.
- iii. CTS cables are chemical proof, water proof, steam proof, but are

slightly affected by lubricating oil.

- iv. The CTS cables are run on well seasoned and straight teak wood batten with at least a thickness of 10mm.

- v. The cables are held on the wooden batten by means of tinned brass link clips (buckle clip) already fixed on the batten with brass pins and spaced at an interval of 10cm for horizontal runs and 15cm for vertical runs.

Conduit Wiring: -

There are two additional types of conduit wiring according to pipe installation

- Surface Conduit Wiring
- Concealed Conduit Wiring

Surface Conduit Wiring: -

If conduits installed on roof or wall, It is known as surface conduit wiring. In this wiring method, they make holes on the surface of wall on equal distances and conduit is installed then with the help of plugs.

Concealed Conduit wiring: -

If the conduits are hidden inside the wall slots with the help of plastering, it is called concealed conduit wiring. In other words, the electrical wiring system inside wall, roof or floor with the help of plastic or metallic piping is called concealed conduit wiring. It is the most popular, beautiful, stronger and common electrical wiring system nowadays.

- I. In conduit wiring, steel tubes known as conduits are installed on the surface of walls by means of pipe hooks (surface conduit wiring) or buried in walls under plaster and VIR or PVC cables are afterwards drawn by means of a GI wire of size if about 18SWG.
- II. In Conduit wiring system, The conduits should be electrically continuous and connected to earth at some suitable points in case of steel conduit. Conduit wiring is a professional way of wiring a building. Mostly PVC

conduits are used in domestic wiring.

- III. The conduit protects the cables from being damaged by rodents (when rodents bites the cables it will cause short circuit) that is why circuit breakers are in place though but hey! Prevention is better than cure. Lead conduits are used in factories or when the building is prone to fire accident. Trunking is more of like surface conduit wiring. Its gaining popularity too.

- IV. It is done by screwing a PVC trunking pipe to a wall then passing the cables through the pipe. The cables in conduit should not be too tight. Space factor have to be put into consideration.

Types of Conduit: -

Following conduits are used in the conduit wiring systems (both concealed and surface conduit wiring) which are shown in the above image.

- Metallic Conduit
- Non-metallic conduit

Metallic Conduit: -

Metallic conduits are made of steel which are very strong but costly as well.

There are two types of metallic conduits.

- Class A Conduit: Low gauge conduit (Thin layer steel sheet conduit)
- Class B Conduit: High gauge conduit (Thick sheet of steel conduit)

Non-metallic Conduit: -

A solid PVC conduit is used as non-metallic conduit now days, which is flexible and easy to bend.

Layout Diagram: -

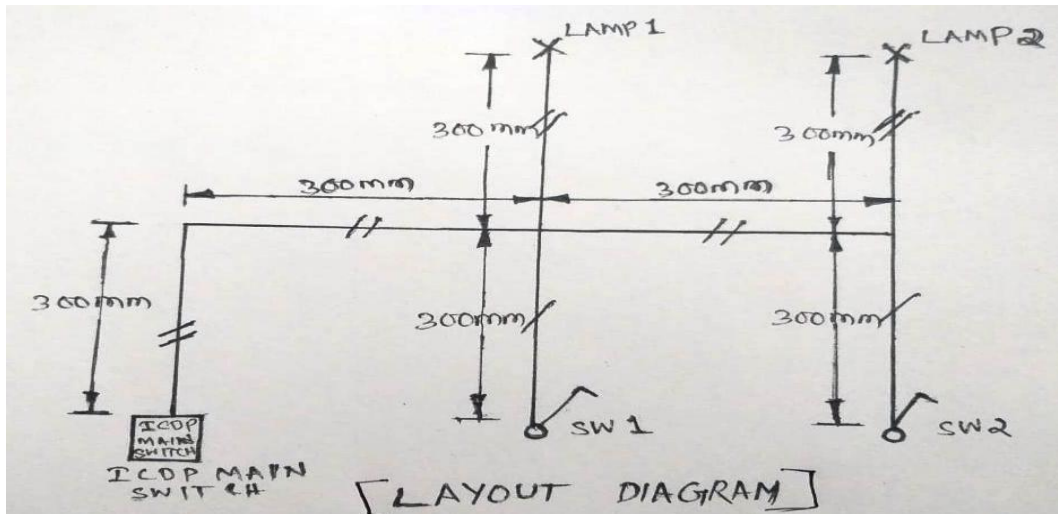

Circuit Diagram:-

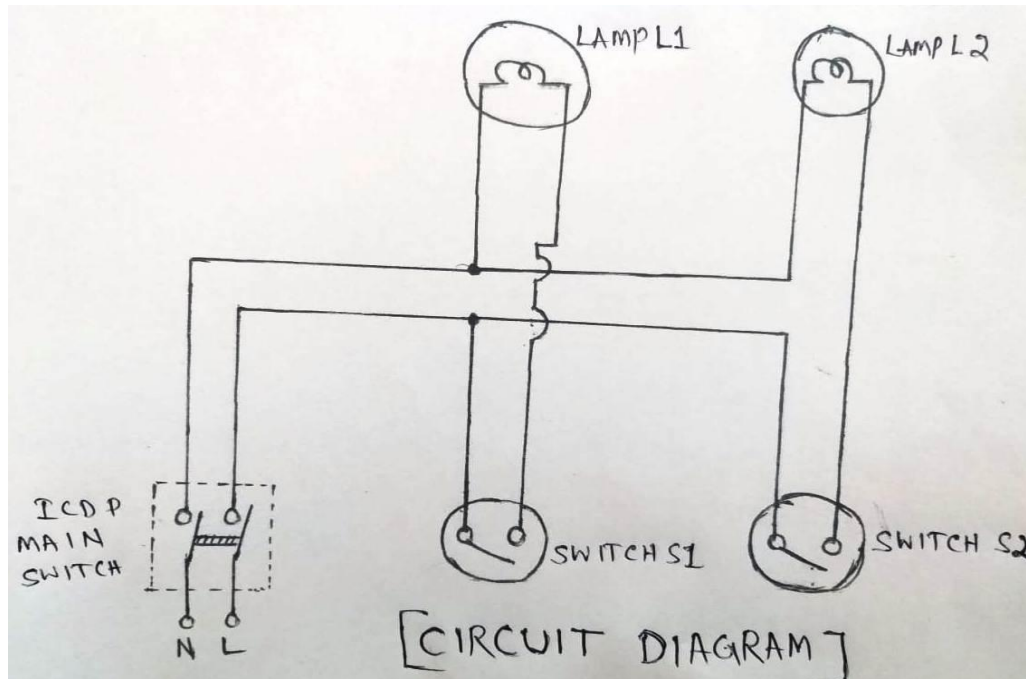

Testing of installation:- After inspection the following tests shall be carried out before an installation or an addition to the existing installation is put in service.

- Continuity or Open Circuit Test
- Polarity Test

Continuity or Open Circuit Test: -

- I. This test is carried out to check the continuity of cables in the individual sub-circuit
- II. Before conducting this test, the main and all the distribution circuit fuses should be removed.
- III. The phase and the neutral of the individual circuits should be identified from the distribution board and segregated.
- IV. Place all bulbs in position; connect fans to respective ceiling roses, regulators and switches, short all socket outlets by linking the phase and neutral.

- V. Connect the Megger terminal E and L to the individual circuit phase and neutral and rotate the Megger.
- VI. By switching the switches ON and OFF one by one, the Megger should show zero reading and infinity alternatively.

- VII. If the Megger shows no continuity in the ON condition of the switch, then the particular circuit is deemed to be open.
- VIII. On the other hand, if the Megger shows continuity in both the ON and OFF positions of the switch, this indicates short in the particular circuit.
- IX. All the shorting links should be removed before switching ON the supply.

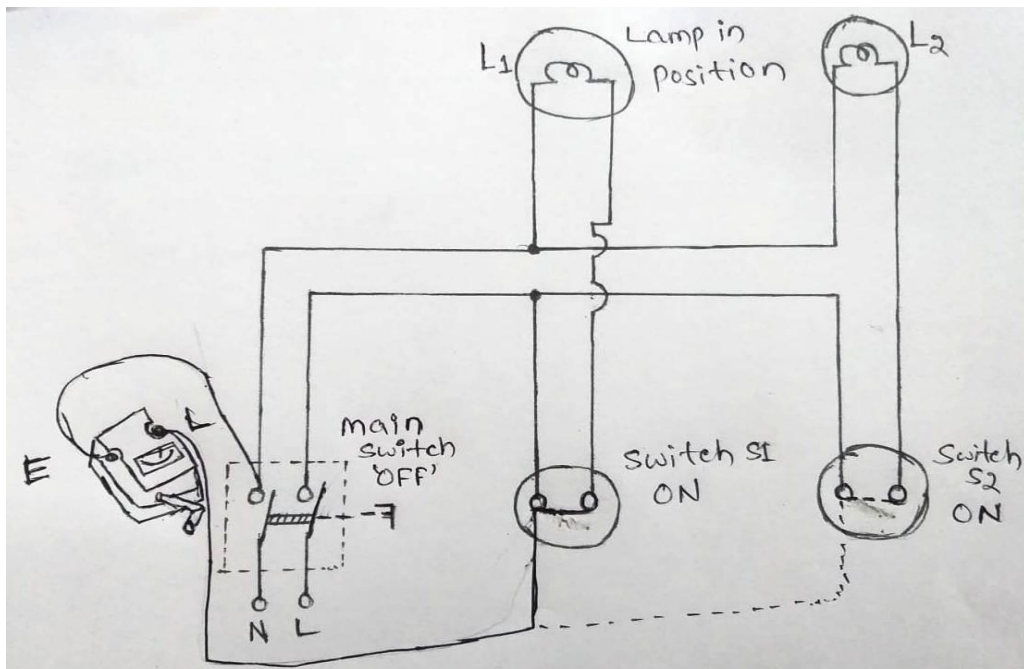

[Continuity or Open Circuit Test]

Polarity Test:-

- I. This test is conducted to check whether switches are connected in phase/live cable or not.
- II. For conducting this test, the lamps are removed from the lamp-holders, the fan regulators are kept in the OFF position and the fuses inserted in the main and distribution board.
- III. Remove the switch covers and switch ON the supply.
- IV. Connect one end of the test lamp to the earth continuity conductors and the

other end of the test lamp to the switch terminals alternatively.

- V. Lighting of the test lamp indicates that the phase or live cable is controlled by switch.

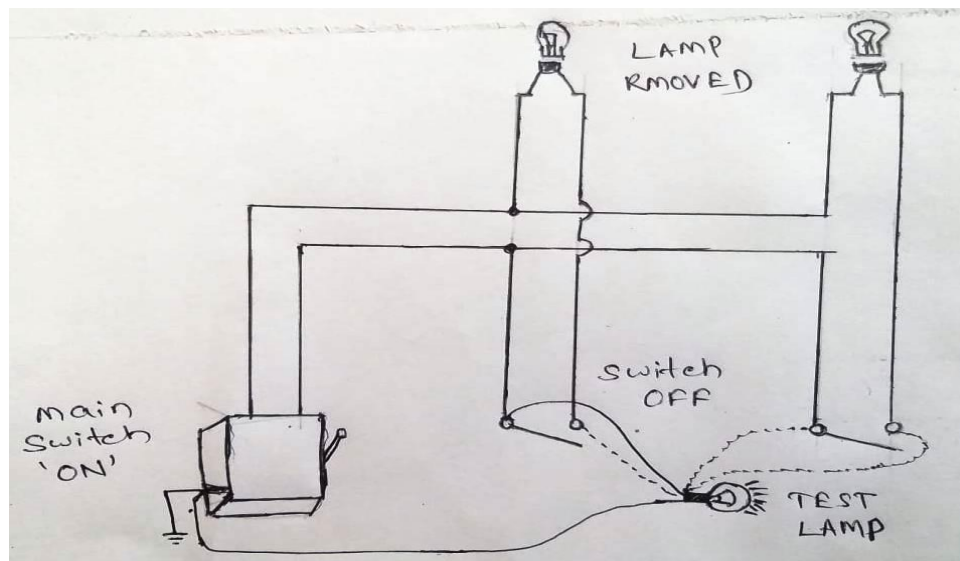

[Polarity Test]

Procedure: -

1. We should take all the tools and material.
2. Cut the two numbers of switch board according to the size of switch and fit the switches.
3. Make hole on other two switch board for lamp holder and fit the holders.
4. Fit the ICDP main switch with the help of screws on the wiring board.
5. Fit the switch boards and holders on the wiring board as per layout diagram.
6. Cut the conduit pipe as per the layout diagram.
7. Cut the wires as per the circuit diagram.
8. Put the wires in the conduit pipe.
9. Fix the conduit pipe with the help of screws and clip.
10. Make the connection as per the circuit diagram.
11. Test the wiring as per the guidelines.
12. Switch ON the ICDP main switch.

Conclusion:- From the above experiment, we learnt about the residential building wiring by CTS and conduit wiring system using main two points and testing the installation by test lamp method and a megger.

Experiment - 06

Aim- Fault finding & repairing of Fan- prepare an inventory list of parts.

APPARATUS REQUIRED:-

Sl. No	Name of the Equipment	Specification	Quantity
1	Ceiling Fan	85W, 220V	1no
2	Insulated Combination Pliers	150mm	1no
3	Screw driver	200mm	1no
4	Line Tester	1100v, 6__	1no
5	Double ended Spanner	-----	1 Set
6	Lamp	100w	1no
7	Inside Bearing Puller	-	1 no
8	Hammer	250gm	1 no
9	Outside Bearing Puller	-	1no
10	Connecting Wires	2.5 sq mm	As Per Required

Theory: -

Ceiling

Fan:-

The function of a fan is to circulate air for cooling purposes. The capacity of the fan is usually expressed in cubic feet per minute and is determined largely by the length, pitch and speed of blades.

Parts of Ceiling Fan: -

The ceiling fan consists of a

- Rotating part
- Stationary part

Rotating Part:-

- Body (rotor)

- Fan Blades
- Bearings
- Squirrel cage winding. (Rotor)

Stationary Part:-

- Canopy
- Shackle, bolt, nut and split pin
- Suspension rod (down rod)
- Terminal block
- Capacitor
- Stator

winding The Stator

winding has a

- Starting winding
- Running winding

Construction:-

- I. The rotor and bottom cover are integrally diecast in high conductivity aluminum alloy which gives better accuracy and thus improves the efficiency of the cooling system.
- II. The present day fan motor has a capacitor to provide for a good starting torque.
- III. The top cover is made of aluminum diecast.
- IV. The fan blades are made from aluminum sheet. The performance of a fan depends on the number of blades and their pitch angle i.e. 10 to 15°.
- V. Ceiling fans are available with three or four blades. The blade is fixed to the top cover and fastened by clamps and bolts.
- VI. The body (rotor) and blades rotate freely with the help of ball bearing or bush bearing which are housed on the top and bottom covers of the fan
- VII. The entire unit is then hung to from the ceiling with a suitable G.I. pipe threaded on both sides and tightened with a suitable check nut and with a split pin so as to prevent the entire unit from failing.
- VIII. The ceiling top clamp must be fitted to the ceiling hook with a shackle and bolt and nut.

- IX. When the supply is given to the starter winding, a rotating magnetic field is created.
- X. The starting winding is connected in series with a capacitor and the running winding is connected across the supply.
- XI. The two winding cause a rotating magnetic field.

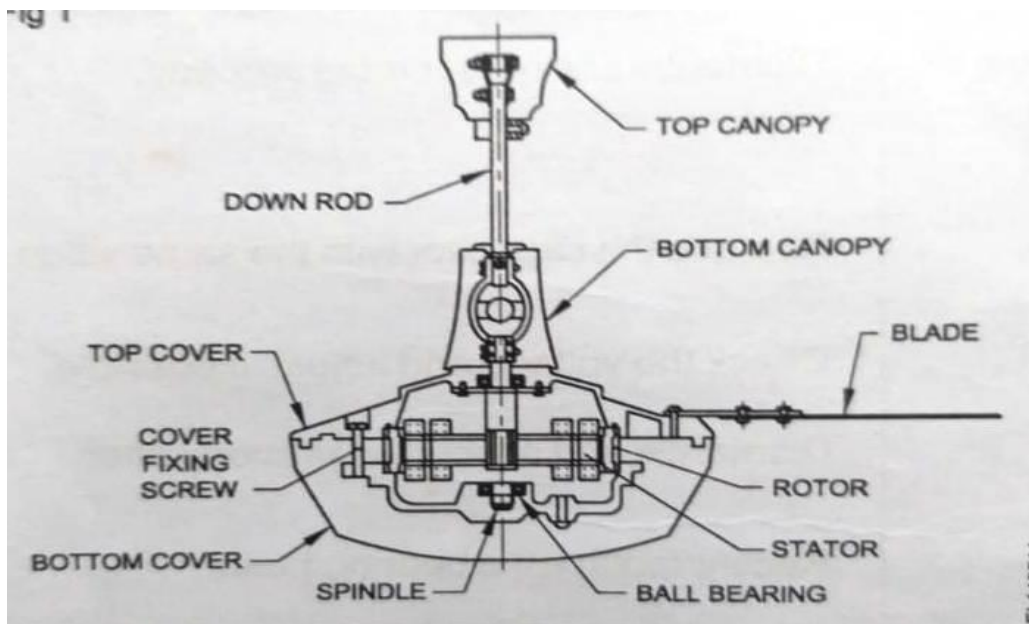
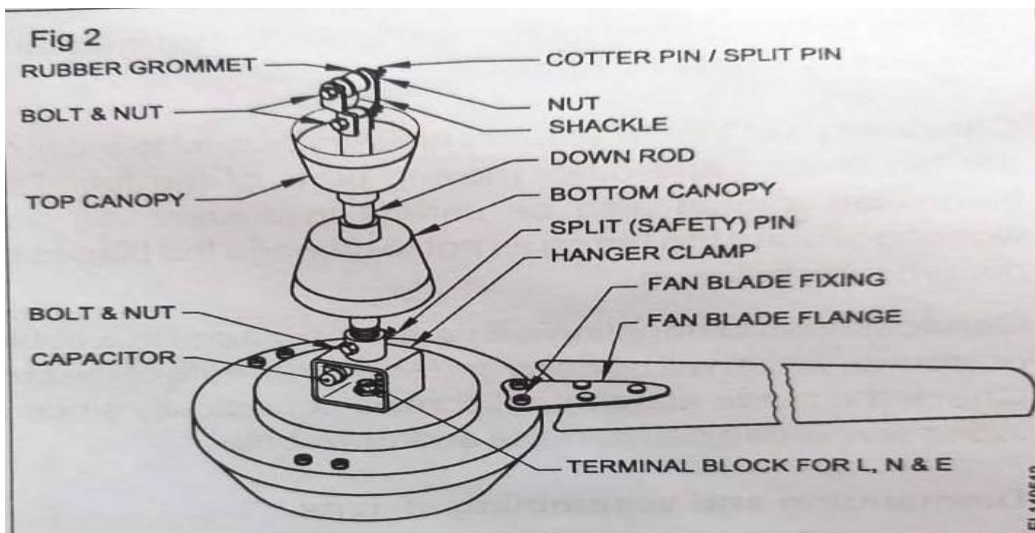

Procedure:-

- 1) Disconnect the supply by switching off the control switch and removing the circuit fuse or switching off the main isolating switch.
- 2) Remove the blades by reaching to the height of the ceiling fan by climbing a stable ladder or table.
- 3) Disconnect the wires from the ceiling rose.
- 4) Lower top canopy.
- 5) Bring down the fan after removing the bolt from the shackle and clamp.

- 6) Disconnect the supply cord from the terminal block and separate the down rod along with the canopy from the condenser house.

- 7) Note down the connection and color of wires and disconnect the fan terminal from the terminal block.
- 8) Mark and unscrew the cover fixing screws and separate out the bottom cover and rotor.
- 9) Remove the split pin and the set screw.
- 10) Remove the capacitor from the housing.
- 11) Pull out the rotor and stator from the top cover.
- 12) Inspect all the parts which were removed.
- 13) Replace the defective components.
- 14) Assemble the dismantled parts in the reverse order to that of dismantling.
- 15) Before installing the ceiling fan, insulation test between the winding and body must be done.

Conclusion: - From the above experiment, we learnt about the fault finding & repairing of a ceiling fan.

Experiment - 07

Aim- Find out fault of DC generator, repair and test it to run.

APPARATUS REQUIRED:

Sl. No	Name of the Equipment	Specification	Quantity
1	DC Shunt Generator	2KW, 220V, 1500 rpm	1no
2	Insulated Combination Pliers	150mm	1no
3	Screw driver	200mm	1no
4	Line Tester	1100v, 6__	1no
5	Double ended Spanner	-----	1 Set
6	Lamp	100w	1no
7	Multimeter	Digital Type	1no
8	Hammer	250gm	1 no
9	Bearing Puller	-	1no
10	Connecting Wires	2.5 sq mm	As Per Required

Theory:-

Maintenance:- By doing maintenance on electrical machines we can eliminate major failures of the machines, accidents, heavy repair costs, and loss of production time.

Preventive Maintenance:- Preventive maintenance of electrical machines consists of routinely scheduled periodical inspections, tests, planned minor maintenance repairs and a system of maintaining inspection records for future reference. Preventive maintenance is a combination of routine and planned operations.

The following schedule is recommended for DC machine

- (i) Daily Maintenance
- (ii) Weekly Maintenance

- (iii) Monthly Maintenance
- (iv) Half-yearly Maintenance
- (v) Annually Maintenance

Testing after Maintenance:-

Ground Test:- This method is used to locate the ground fault of a dc machine. Megger is the most appropriate one for this ground test. In this method, one prob of the test lamp which is in the neutral line is connected to the earth terminal stud of the machine. The other prob which is in the phase line is connected to the test lamp. The lamp prob should be touched with each terminal of a dc machine. In a good condition machine, the lamp should not light, but if the light glow, then mark the terminal and immediately re-insulate the winding with varnish and tape. If the coil burnt out, which will be identified by the decolorization of coil or smell, then rewinding should be done.

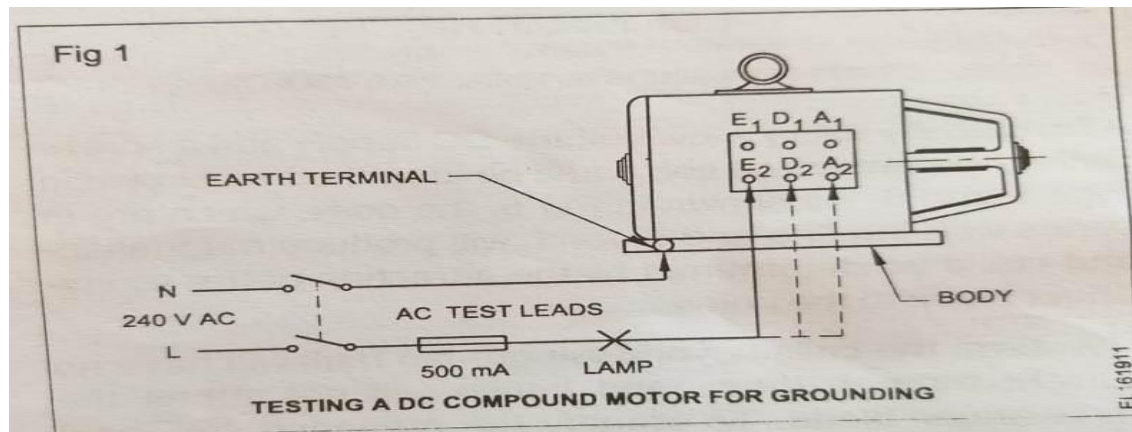

Open Circuit Test:- This test is conducted to determine the correctness of winding continuity. This test should be done must before conducting insulation test by the megger, because to sure that circuit will complete before measure the insulation resistance. Depending upon the type of dc machine different tests need to be conducted. In this method the neutral prob should connected to the one end of the winding terminal and the line prob should connected another end of winding terminal. In dc compound motor the light should glow bright.

Some other reason of open circuit in DC machine:-

- (i) The brushes not making proper contact with the commutator.
- (ii) Dirty or severely pitted commutator.
- (iii) Break in the pigtail connection or jumper connection of the brushes.
- (iv) Break in the field circuit.
- (v) Break in the armature winding.

Fig 2

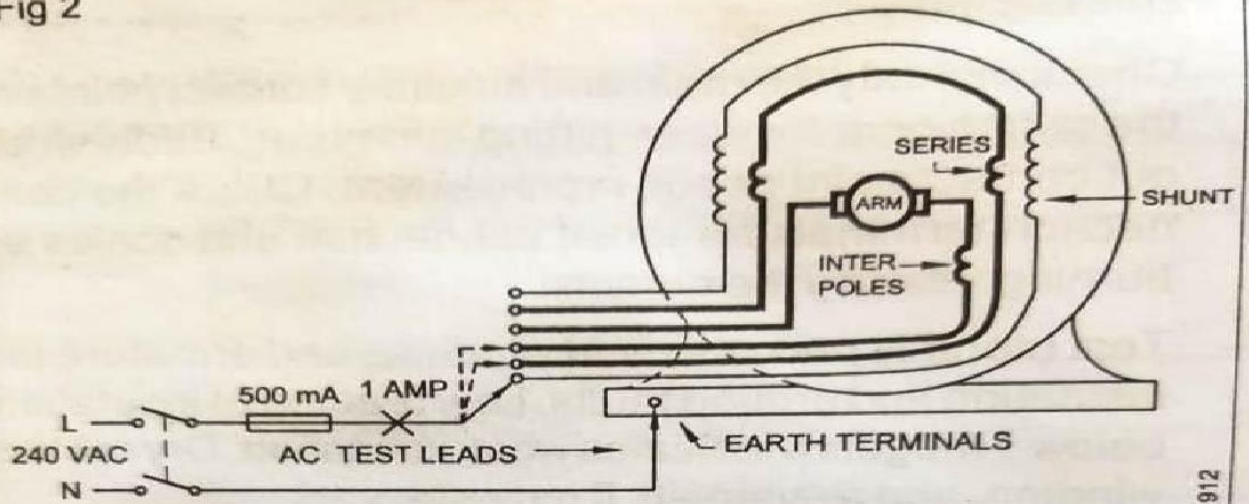

TESTING A DC COMPOUND MOTOR FOR GROUNDS

EL161912

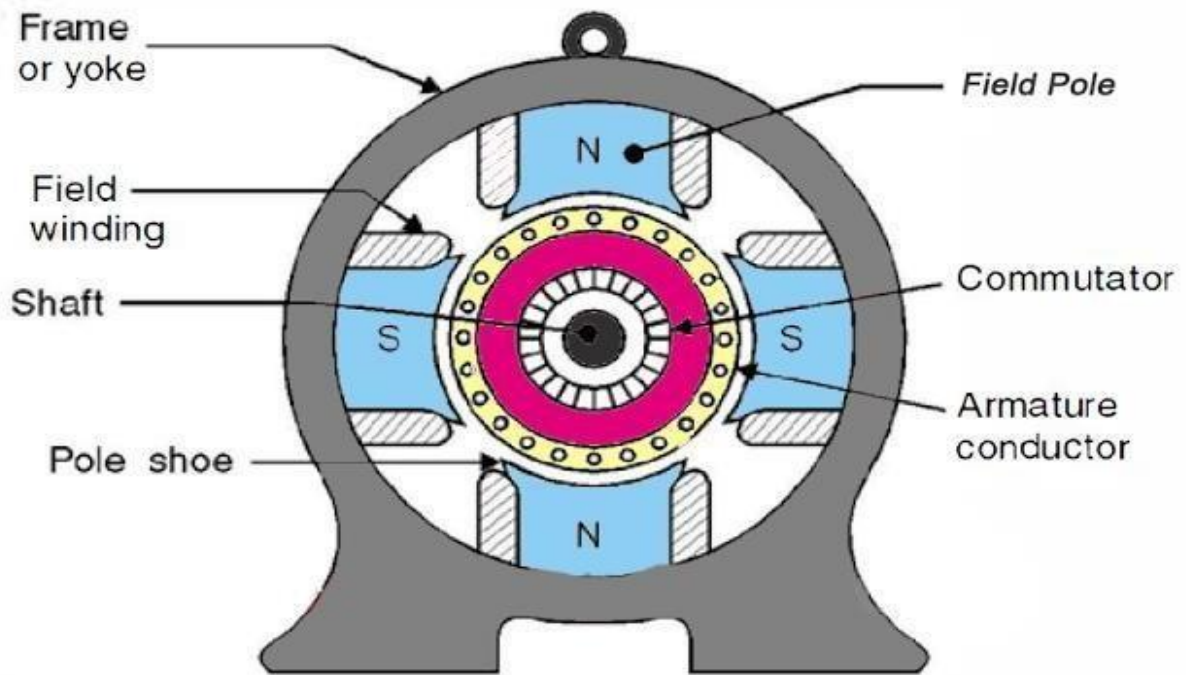

[Yoke]

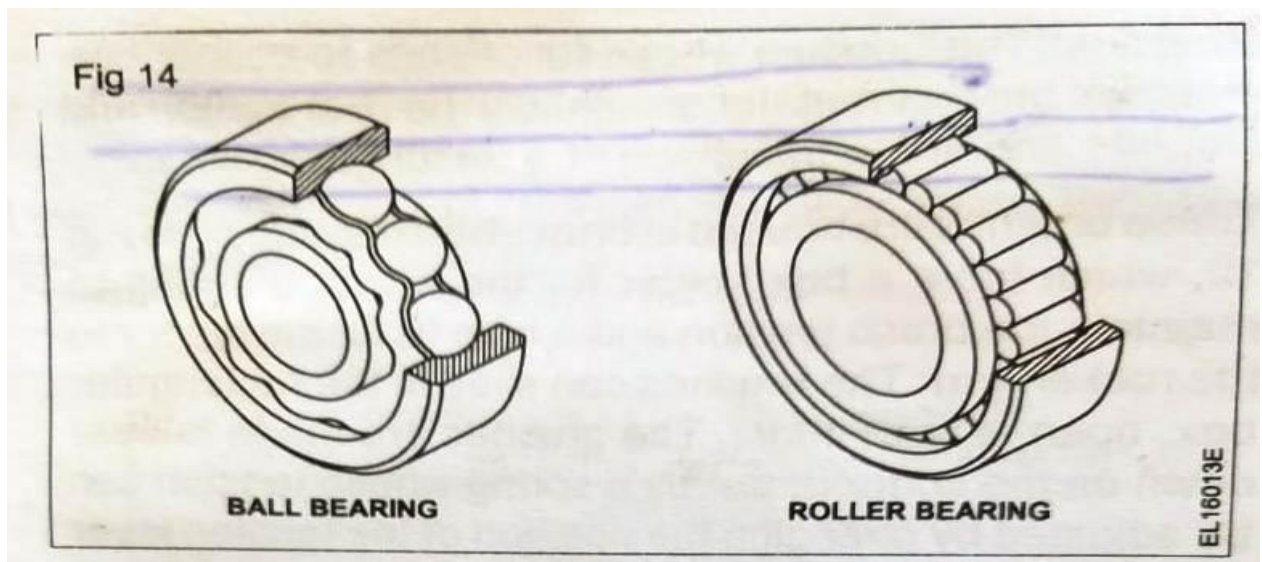

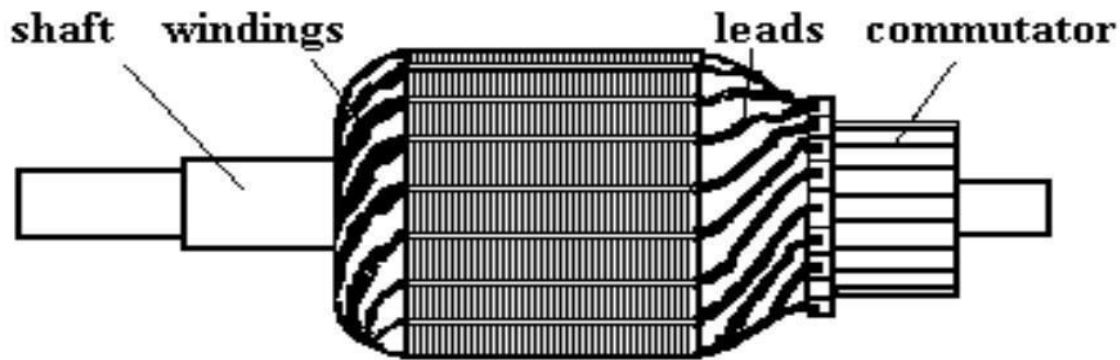

[Armature]

Procedure:-

1. We should take all the tools & instrument for this experiment.
2. Open the terminal box and disconnect the wires.
3. Disconnect the supply from mains.
4. Lift the generator from base to ground.
5. Unscrew the end plates.
6. Open the armature from the machine.
7. Pull the bearing with the help of bearing puller.
8. Clean the bearing with diesel and re-grease it.
9. If the bearing is in bad condition replace it.
10. Varnish the armature winding and field winding.
11. Clean the commutator with the help of sand paper.
12. Assemble the generator.
13. Test the field terminals and test the armature with the help of open circuit test and short circuit test.

Conclusion: - From the above experiment, we learnt the faults of DC generator and repair.

Experiment - 08

Aim- Find out fault of DC motor starters and AC motor starter – prepare an inventory list of parts used in different starter.

APPARATUS REQUIRED:

Sl. No	Name of the Equipment	Specification	Quantity
1	3- point Starter	220v,10A	1no
2	4-point Starter	220v,10A	1no
3	3-phase D.O.L Starter	440v,15A	1no
4	Insulated Combination Pliers	150mm	1no
5	Screw driver	200mm	1no
6	Line Tester	1100v, 6__	1no
7	Multimeter	Digital Type	1no

DC Motor Starter:-

Servicing the Starter:- The starting resistance of 3-point & 4-point starters is made up of coiled Eureka wire and it is fixed between the studs of the starter. The brass studs are arranged on the face plate of the starter in a semi circular form. The studs are firmly fixed on the insulated face plate. During the maintenance the studs should be dressed with zero number sandpaper, if the burns are small and a smooth file should be pitting and for big burns should be cleaned properly with a contact cleaner. In case the starter resistance is found open, replace it with a new resistance coil as per the original specification of the manufacturer.

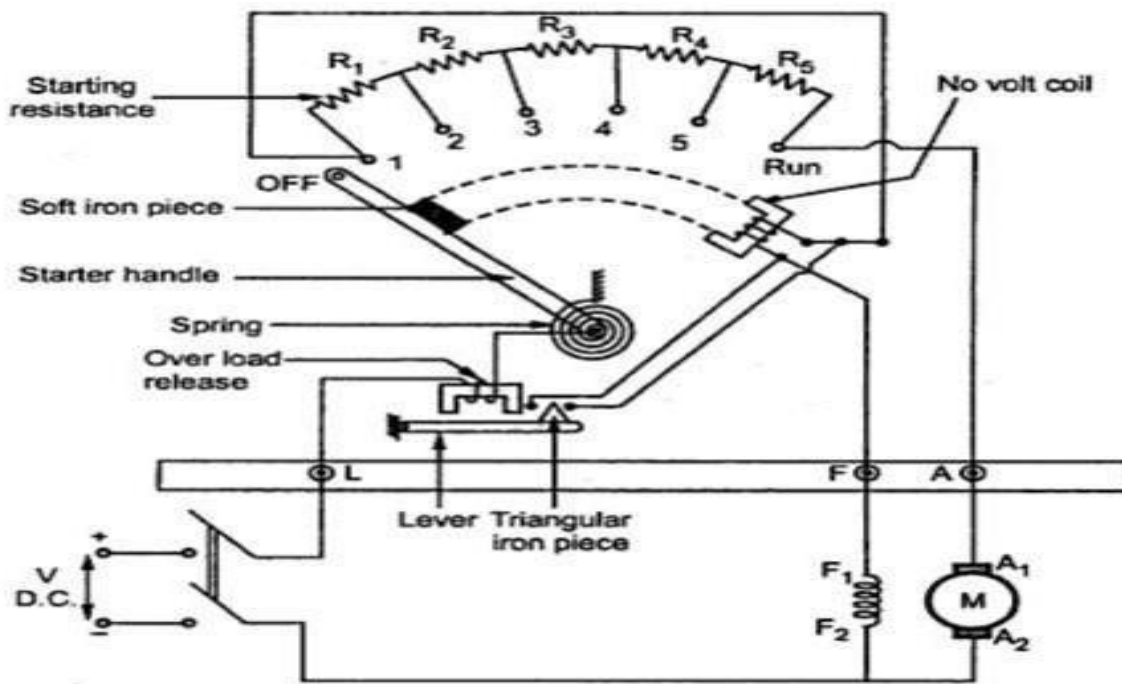

[Three Point Starter]

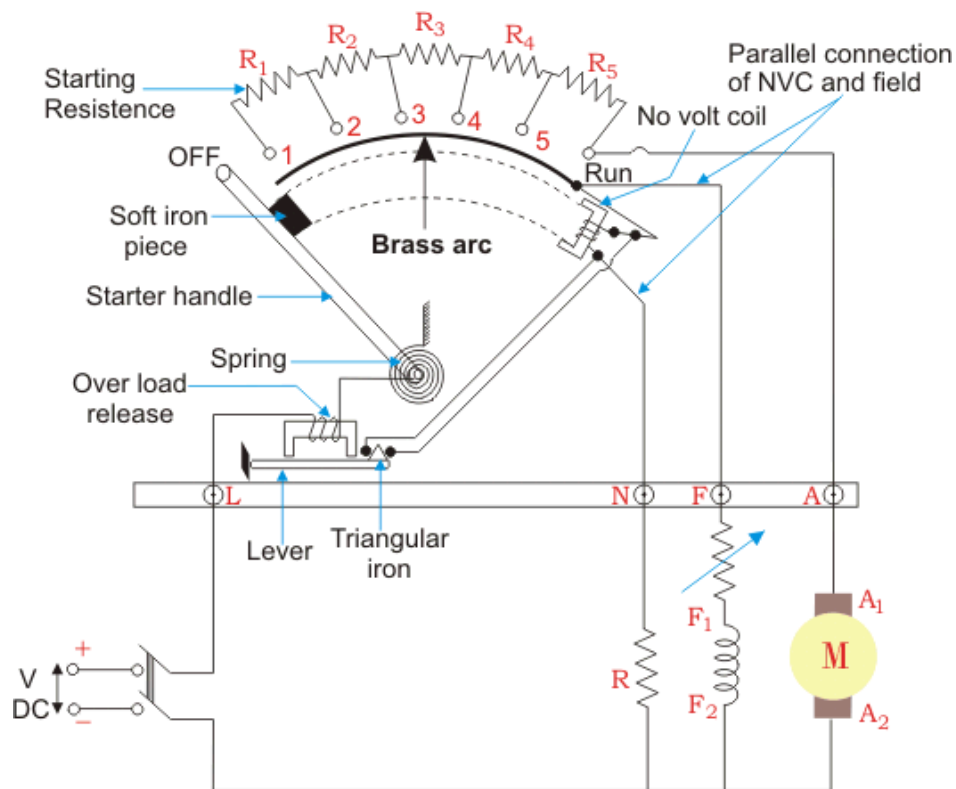

Four Point Starter

Handle:- The handle of the face plate starter consists of a moveable arm attached with a spiral springs which acts against the magnetic action of the no volt coil. In case the spring becomes weak, the arm will not come to the off position even through the supply fails. In this case, it is necessary to replace the springs as per the manufacturer specification. Also ensure during maintenance, proper pressure of the movable contact of the arm is available against the brass studs of the face plate. If proper tension is not found then the starter handle is to be tightened with the help of fixing screw by adding one or two flat washers on the top of the handle.

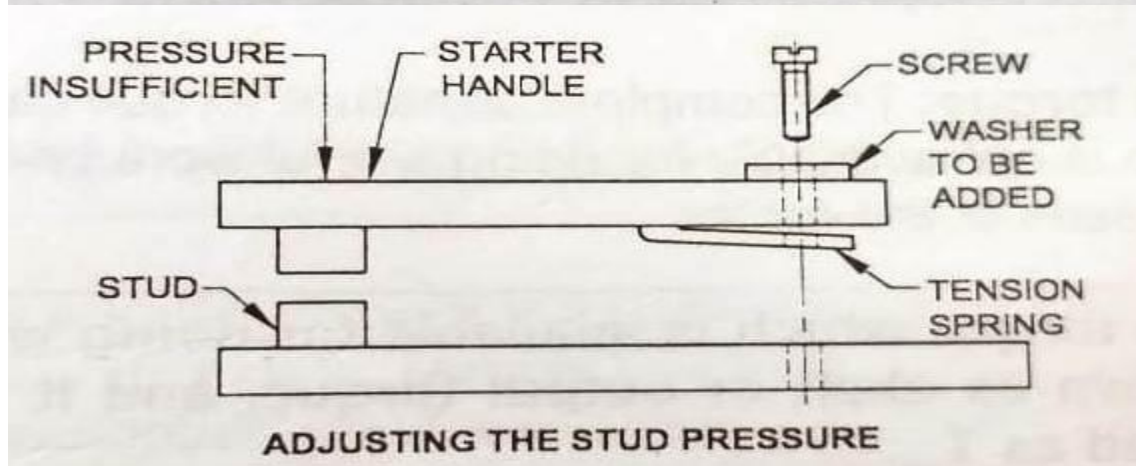
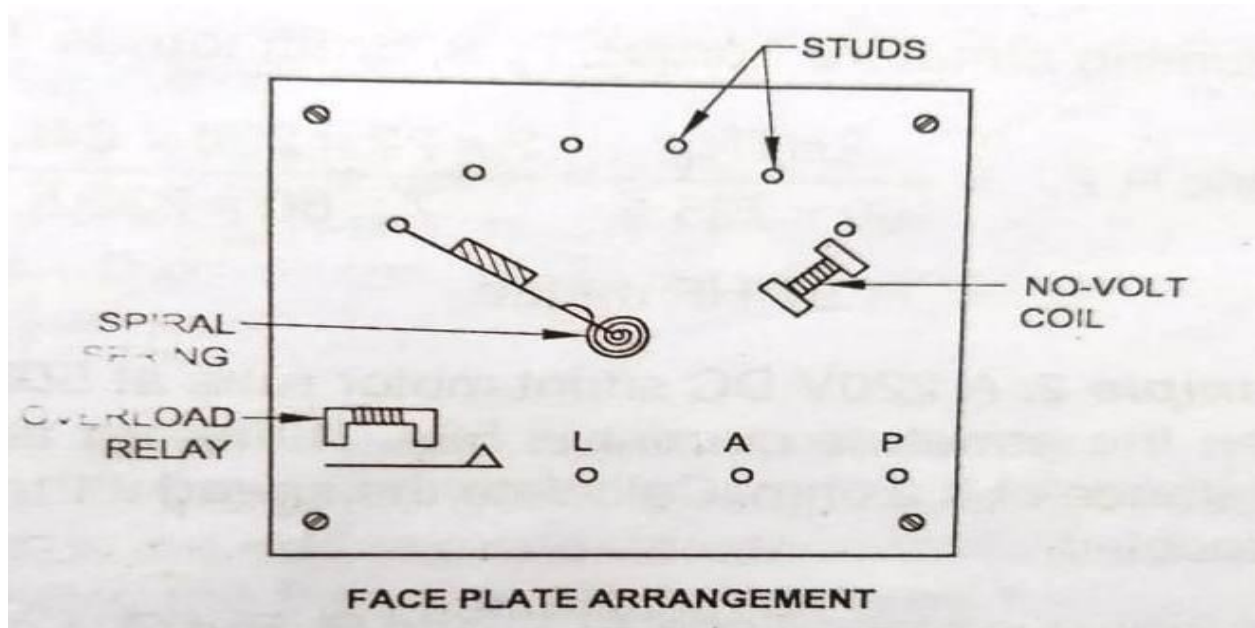

Maintenance and service of no-volt coil assembly:- The no-volt coil is connected in series with the field winding in the case of 3-point starter and in parallel with the supply through a limiting resistance in the of 4-point starter. The no-volt coil wound with a thin insulated wire and has a number of turns.

When the handle of the starter is moved to the running position, the armature of the handle should be touching the core assembly of the no-volt coil. In case the core assembly is not touching properly, loosen the mounting screws of the core/coil assembly, align the core and tighten the screws.

If the NVC is not energized check visually the condition of the NVC. Measure the value and resistance of the coil as well as the insulation value and make a note of these readings. Periodically check these values and compare these with original manufacturer's data. In any case, at any time if the value falls below 80% of the normal value, then replace it with a new NVC of the same specification.

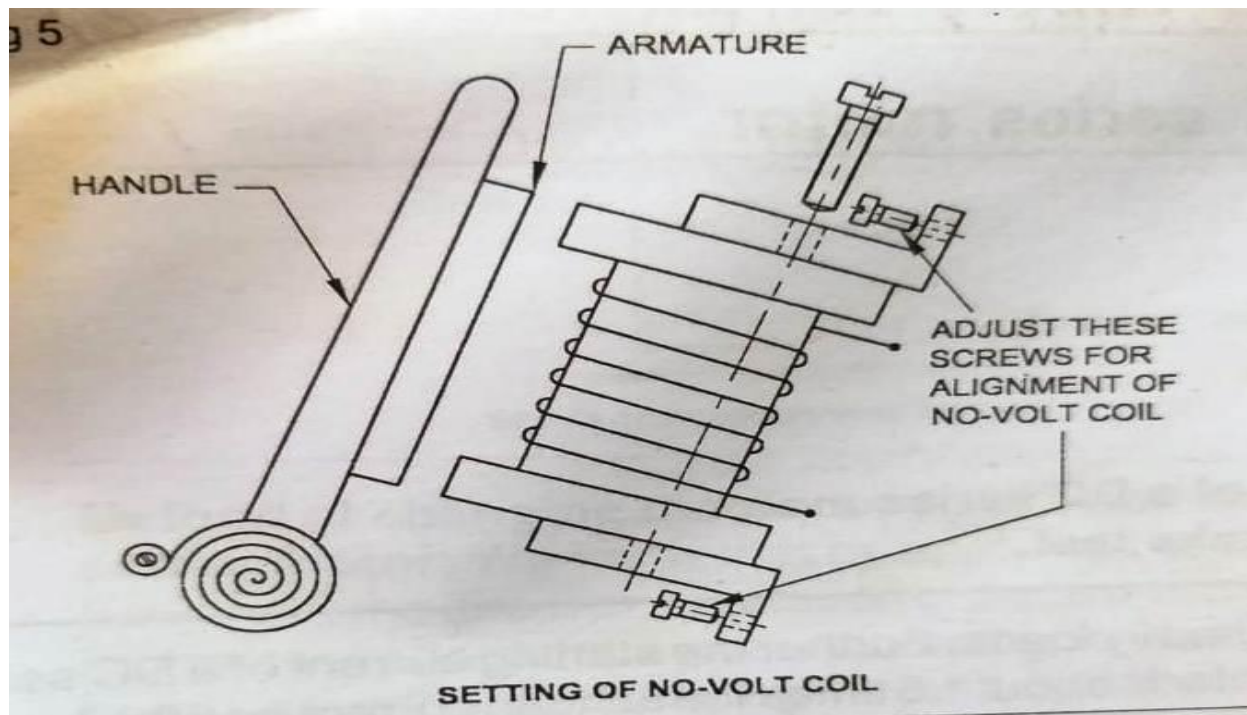

Maintenance of overload relay: - A magnetic overload relay is provided near the handle on the left side of the starter face plate; underneath the overload relay an armature is provided and it is adjusted as per the load current of the motor.

To test the overload relay the motor has to be loaded and the tripping of the overload relay to be observed. In case the overload relay trips at a lower current or higher current value when compared to set current value the current scale has to be recalibrated. In the case of chattering noise observed the no-volt coil the surfaces of the core assembly and armature need to be cleaned.

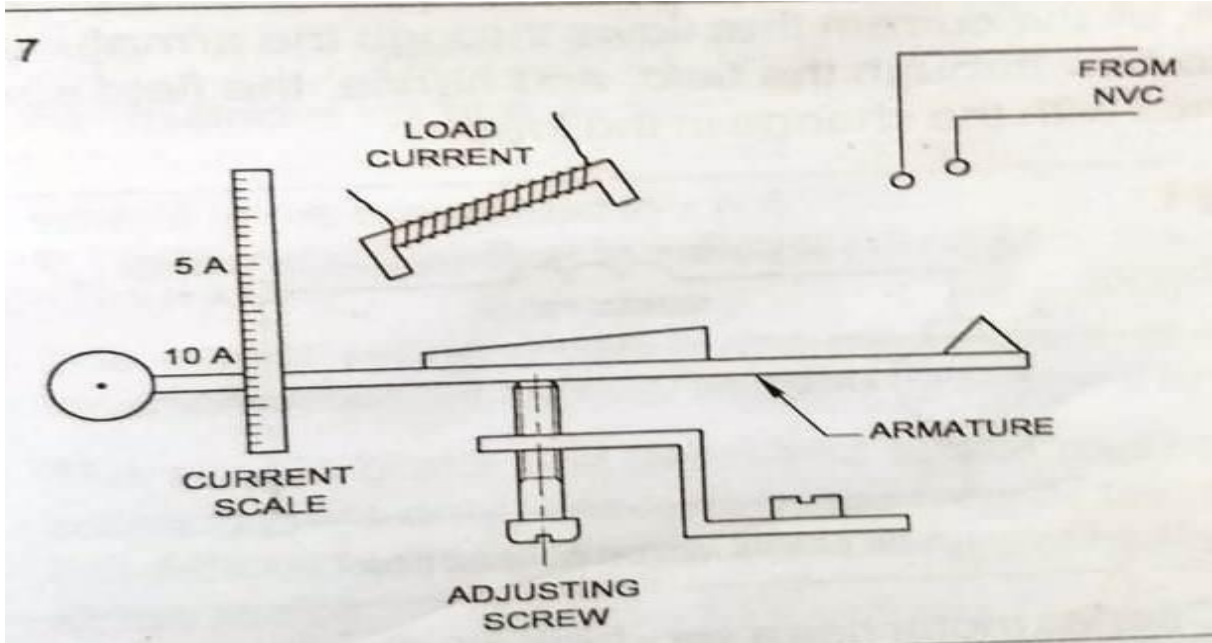

AC Motor Starter: -

The D.O.L. starter consists of the fixed contacts, moveable contacts, no-volt coil, overload relay and stat button which is in green colour and stop button in red colour with a locking arrangement. The main purpose of the contactor is to make

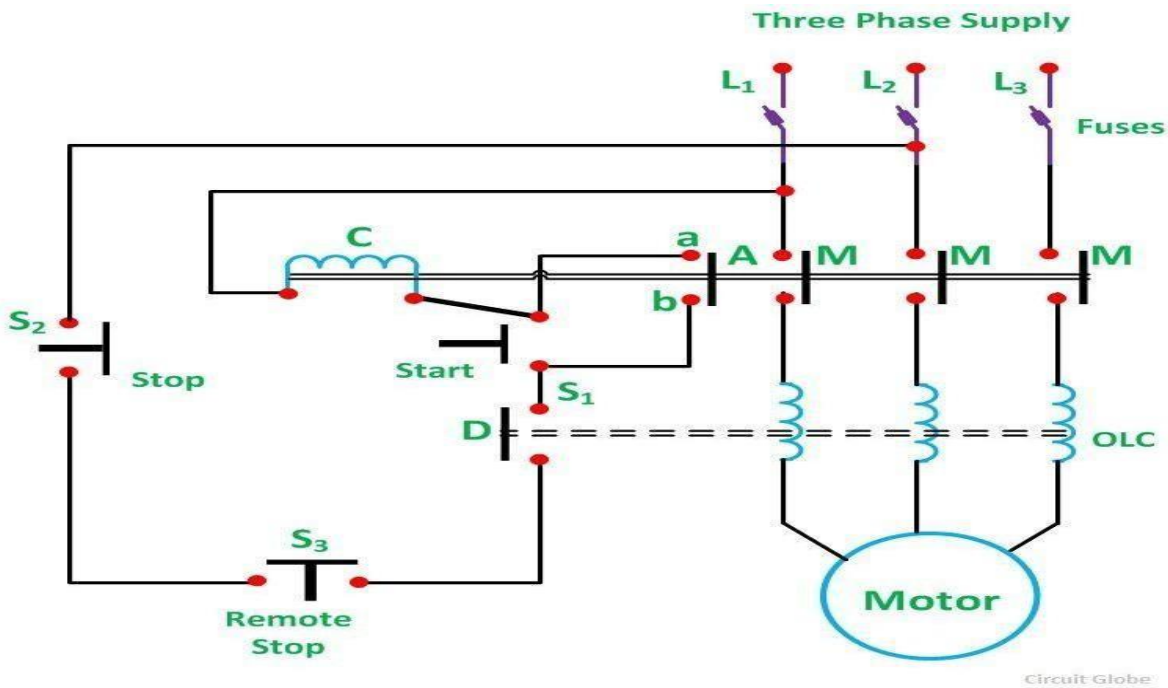

and break the motor circuit. These contacts in the contactor suffer maximum wear,

due to frequent use and hence these contacts are made of silver alloy material.

No-volt Coil:- A NVC acts under –voltage release mechanisms disconnecting supply to the motor when the supply voltage fails or is lower than the stipulated value. Thus the motor will be disconnected from the supply under these conditions. The NVC magnetic system consists of a laminated iron core for minimizing the eddy current and hysteresis losses. Shading rings are provided on the pole faces of the magnetic core to reduce the hum level and chattering which is present due to A.C supply.

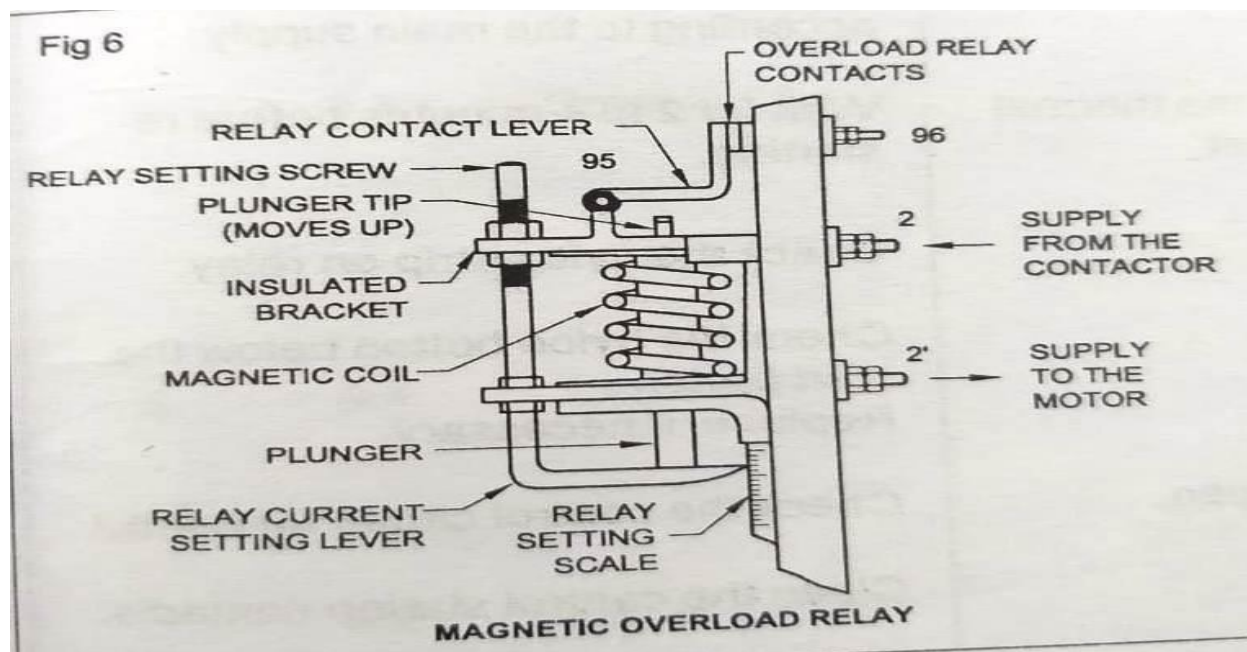

Overload Relay:- A 1 overload relay unit is provided for the protection of the motor. This unit consists of a triple pole, bimetallic relay housed in the sealed bimetallic enclosure. This is provided with a current setting arrangement. After tripping on overload, the relay has to be reset by pressing the stop button. The relay can be reset only after bimetallic strips get cooled sufficiently.

If the overload relay is not functioning properly i.e. not tripping the motor as per setting of the current rating, then replace it with a new one as per with the original specification of the manufacturer.

Conclusion:- From the above experiment, we learnt about the AC and DC motor starter repairing and trouble shooting.

Experiment - 09

Aim- Dismantle, over haul and assemble a single phase induction motor. Test and run it – prepare an inventory list.

APPARATUS REQUIRED:

Sl. No	Name of the Equipment	Specification	Quantity
1	1 – phase Induction Motor	220v, 1HP	1no
2	Insulated Combination Pliers	150mm	1no
3	Screw driver	200mm	1no
4	Line Tester	1100v, 6__	1no
5	Multimeter	Digital Type	1no
6	Mallet	200gm	1no
7	Bearing puller	-	1no
8	Hammer	250gm	1 no

Theory:- General maintenance and servicing of single phase motor incorporates checking the following area.

- Incoming Cables
- Main switch I.C.D.P
- Starter
- Motor

Incoming Cables:- Checking the incoming cables should be started from the main distribution board. A visual check of the color of cables would indicate whether the cables are underrated and need replacement. While discoloring of cables, throughout the circuit indicate under rating of the cables, the discoloring at ends near terminal connections indicate loose connections. A thorough check up of the tightness of the termination screws is necessary at the distribution board, main switch of the motor, starter and the motor

Checking the main switch:- Normally visual inspection of the inner parts of the main switch will indicate loose connections, improper capacity fuses and badly positioned baffles of contact. Rectify the defects after proper shut down.

Checking the starter: - Before opening the starter switch off the power supply. Starter contacts should be checked for perfect closing with proper tension. Most of the present day's starter contacts could be checked by placing a small thin card board in between the movable and fixed contacts and closing the contactor manually.

Check the contact points for perfect smooth surface. According to the manufacturer's instructions the contact point could be either cleaned with cloth or with the help of smooth sandpaper. Badly pitted or welded contacts need replacement

Check overloads mechanism whether the setting is tallying with the motor current rating. If necessary set them correctly.

Check the no-volt coil mechanism for smooth functioning. NVC resistance could be measured and compared with the earlier measurement. Variation in resistance value or discoloring of the coil indicates the coil needs to be replaced with a similar one.

Checking the motor:- first the motor should be visually inspected for broken parts. Observe the noise while running. The resistance values of winding and insulation value between the winding and frame should be taken before dismantling. These values, when compared with earlier values found in the maintenance history cards, will give sufficient idea to the technician regarding the expected trouble area.

Make it appoint to draw the connection diagram of the terminal plate before disconnecting any lead for testing. While checking the motor continuity checks must be done for both main and starting winding and also in the centrifugal switch. Open circuits in split phase motors are often caused by loose or dirty connections or broken wires.

Once the open winding is detected, dismantle the motor and check the end leads and winding interconnection leads. Most of the faults could be rectified at this stage. In case the open is detected inside the coils of the winding, it is better to rewind it.

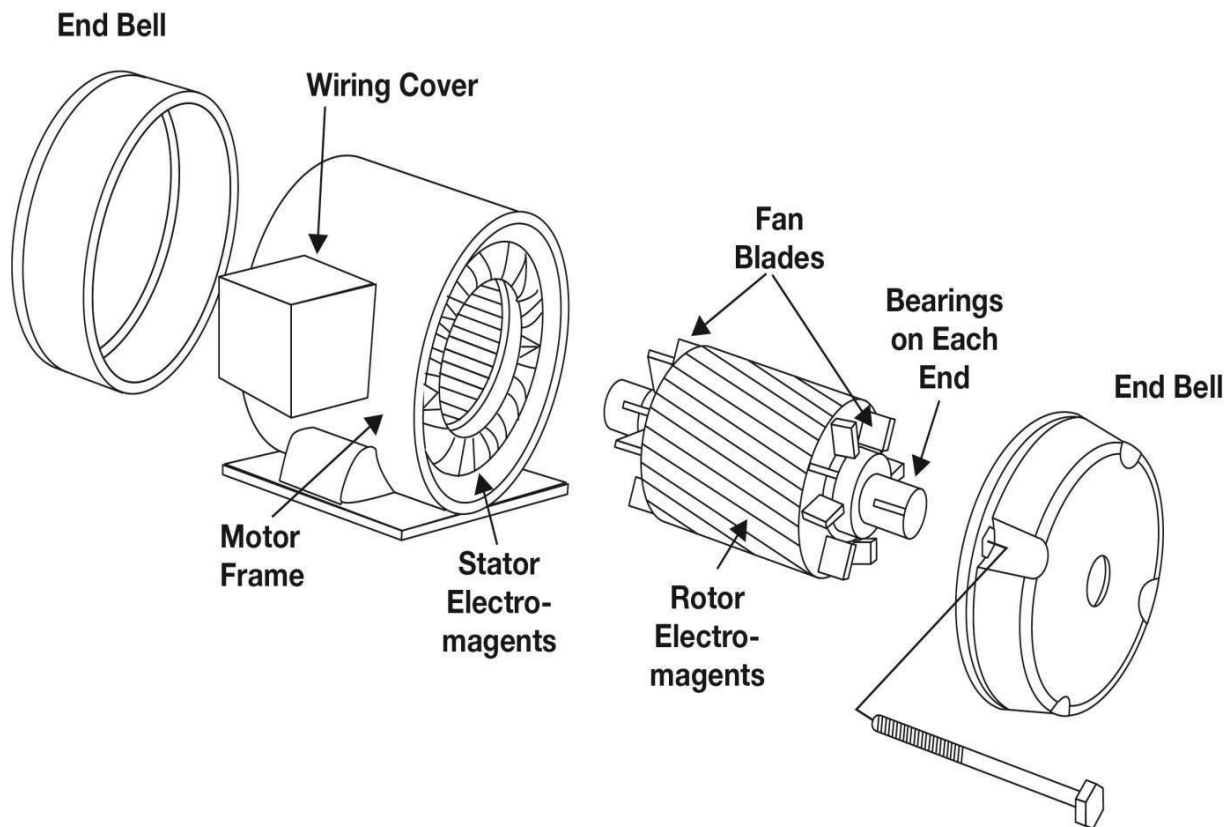

Procedure:-

1. We should take all the tools & instrument for this experiment.
2. Open the terminal box and disconnect the wires.
3. Disconnect the supply from mains.
4. Lift the motor from base to ground.
5. Unscrew the end plates.
6. Open the rotor from the machine.
7. Pull the bearing with the help of bearing puller.
8. Clean the bearing with diesel and re-grease it.
9. If the bearing is in bad condition the replace it.
10. Assemble the motor.

Conclusion: - From the above experiment, we learnt about dismantle, over haul and assemble a single phase induction motor.

Experiment - 10

Aim- Dismantle, over haul and assemble a three phase squirrel cage and phase wound. Test and runthem.

APPARATUS REQUIRED:

Sl. No	Name of the Equipment	Specification	Quantity
1	3 – phase Induction Motor	440v, 2HP	1no
2	3 – phase Slip ring Induction Motor	440V, 2HP	1 no
3	Insulated Combination Pliers	150mm	1no
4	Screw driver	200mm	1no
5	Line Tester	1100v, 6__	1no
6	Multimeter	Digital Type	1no
7	Double ended Spanner	-	1 set
8	Bearing puller	-	1no
9	Hammer	250gm	1 no

Theory:-

Maintenance can be classified into two groups:

1. Restorative (Repairs) Maintenance: It is the most primary type of repairs. It arises after a fault being carried out. Restorative Maintenance has many disadvantages like lesser time for the useful life of the machine, waste of valuable energy, etc. It is also known as Corrective maintenance.
2. Protective Maintenance: This type of maintenance form can be referred to the schedule of planned maintenance actions (i.e. scheduled maintenance) aimed at the prevention of breakdowns and failures. Examples of Protective maintenance are changing of oil, greasing, tightening of the belt, changing of filters, etc.

It can also be defined as -anything that increases the life of equipment, and helps it runs more efficiently.¶

Further, it can be divided into two subgroups of activities

- Continues monitoring;
- Periodic measurements or predictive techniques.

Protective maintenance will generally involve lubricating, cleaning and check for sparking brushes, vibration, loose belts, high temperature and unusual noises. So a planned inspection and maintenance is needed for vast of electrical equipment to keep in proper working condition.

Without a proper maintenance schedule when something goes wrong with a motor it can lead to expensive repairs, can take some leads to replace it with a new one. This is why a proper schedule maintenance schedule is necessary; however, it will not guarantee that motor will not get any trouble, but it will limit the problems.

So the main idea behind motor maintenance is to prevent breakdown rather than repairs them.

Since here we are talking about maintenance of induction motor, and it is of two types

1. Squirrel Cage Type Induction Motor:- Squirrel cage induction motor requires significantly less maintenance as it does not contain brushes, commutators, slip rings.

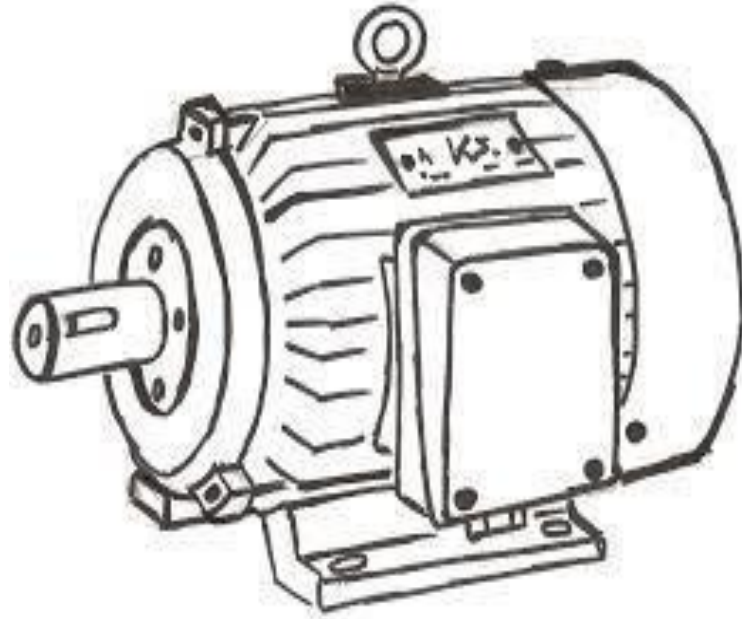

[Three – Phase Squirrel Cage Induction Motor]

2. Wound Rotor Type Induction Motor:- Since it contains slip ring, brushes so it does require maintenance time to time.

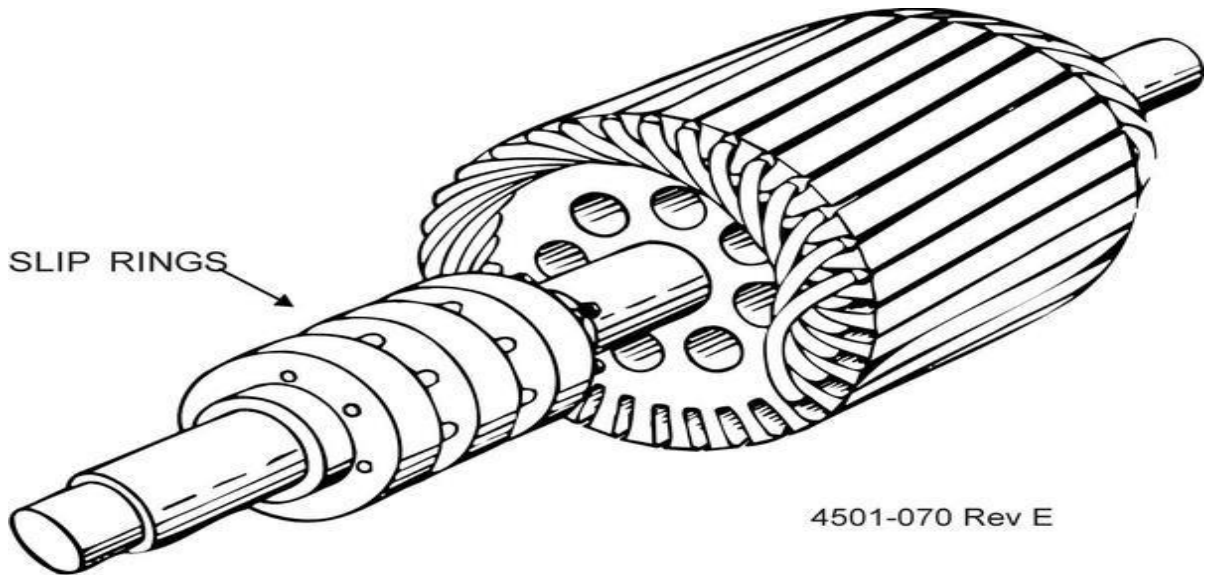

Circuit used to start a wound-rotor motor

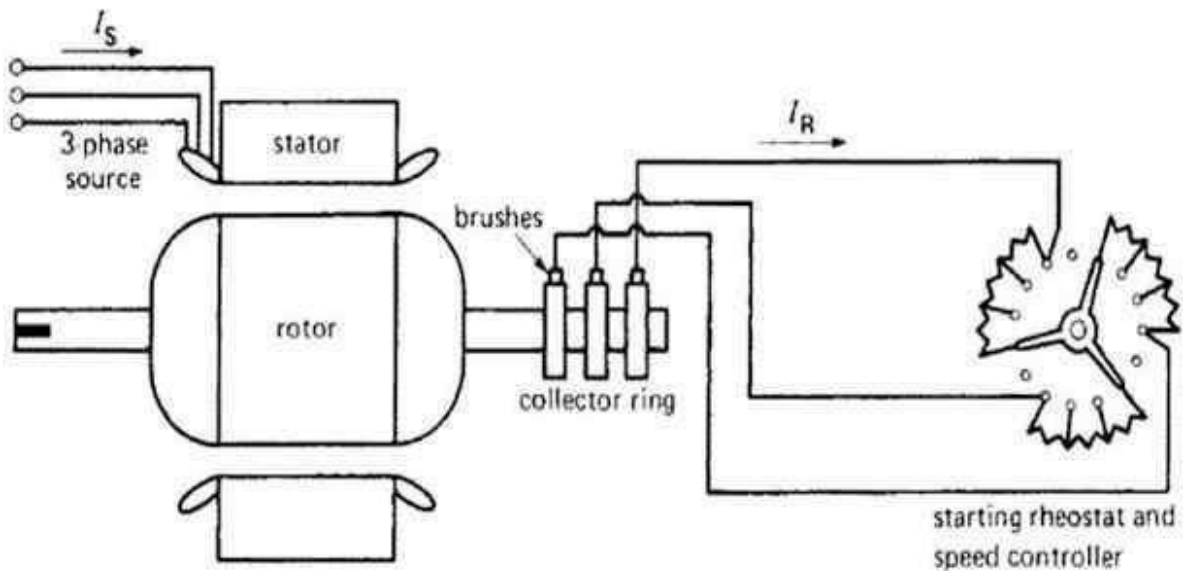

Considering the above discussion most common faults that can be avoided through the adoption of condition monitoring methods:

Stator Winding Faults: - Normally a consequence of overheating, contaminations, etc, possibly causing shorted turns, shorted coils (same phase), phase or coil to ground and single phasing. Such failures create stator electrical imbalance as well as vibrations in the current harmonic content.

Bearing Faults: - It can be caused by incorrect lubrication, mechanical stresses, wrong assembling etc. They can affect all the bearing parts such as inner and outer races, cage and balls or rolls.

Rotor Faults: - These are usually caused by broken bars or broken end rings, rotor misalignment and imbalance.

The primary focus of problems in a three-phase induction motor is in their stators and their supports. The leading causes of failures are superheating, imperfections in the isolation, mechanical bearings, and electrical failures.

So the following inspection schedule (may vary depending on the type of machines and importance of that machine) must be carried out of Induction Motors.

Maintenance Schedule for Induction Motor:-

Daily Maintenance:-

1. Examine earth connections and motor leads.
2. Check motor windings for overheating.
3. Examine the control equipment.

Weekly Maintenance: -

1. Examine commutator and brushes.
2. Examine the starter switch, fuses, and other controls; tighten loose connections.
3. See that machine brought up to rated speed in normal time or not.
4. Check the level of oil in bearings.

Monthly Maintenance:-

1. Overhaul the controllers.
2. Inspect and clean the oil circuit breakers.

3. Renew oil in high speed bearings in damp and dusty location.
4. Wipe brush holders and check the bedding of brushes of slip-ring motors.
5. Check the condition of the grease.

Half- yearly Maintenance:-

1. Clean motor thoroughly, blowing out dirt from windings, and wipe commutator and brushes.
2. Check brushes and replace any that are more than half worn
3. Examine brush holders, and clean them if dirty. Make sure that brushes ride free in the holders.
4. Drain, wash out and replace oil in sleeve bearings.
5. Check grease in a ball or roller bearings.
6. See that all covers, and belt and gear guards are in place, in good order, and securely fastened.
7. Inspect and tighten connections on motor and control.

Annual Maintenance:-

1. Clean out and renew grease in ball or roller bearing housings.
2. Clean out magnetic dirt that may be clinging to poles.
3. Check clearance between shaft and journal boxes of the sleeve bearing motors to prevent operation with worn bearings.
4. Clean out undercut slots in the commutator. Check the commutator for smoothness.
5. Examine connections between commutator and armature coils.
6. Test insulation by megger.
7. Check air gap.

Procedure:-

1. We should take all the tools & instrument for this experiment.
2. Open the terminal box and disconnect the wires.
3. Disconnect the supply from mains.
4. Lift the motor from base to ground.
5. Unscrew the end plates.
6. Open the rotor from the machine.
7. Pull the bearing with the help of bearingpuller.
8. Clean the bearing with diesel and re-grease it.
9. If the bearing is in bad condition the replace it.
10. Assemble the motor.

Conclusion: - From the above experiment, we learnt about dismantle, over haul and assemble a three phase squirrel cage induction motor and phase wound motor.

Experiment - 11

Aim- Overhaul a single phase / three phase variac.

APPARATUS REQUIRED:

Sl. No	Name of the Equipment	Specification	Quantity
1	3 – phase Induction Motor	440v, 2HP	1no
2	3 – phase Slip ring Induction Motor	440V, 2HP	1 no
3	Insulated Combination Pliers	150mm	1no
4	Screw driver	200mm	1no
5	Line Tester	1100v, 6__	1no
6	Multimeter	Digital Type	1no
7	Double ended Spanner	-	1 set
8	Bearing puller	-	1no
9	Hammer	250gm	1 no

Theory:-

Variac regulator belongs to a small type of power supply machine with capacity 0.2kva, 0.5kva, 1kva, ect. and adjustable output voltage 0-250v. This machine is widely applied in the electrical experiment, electronic circuit experiment, ect. in the basic laboratory. The variac regulator failure rate is very high because of the production quality, voltage regulating mode, and student's frequent voltage regulating. However, essentially the majority of failures are caused by improper use and maintenance. Therefore, the maintenance and repair is very important. This article below is about the analysis of the failures in maintenance and providing maintenance measures.

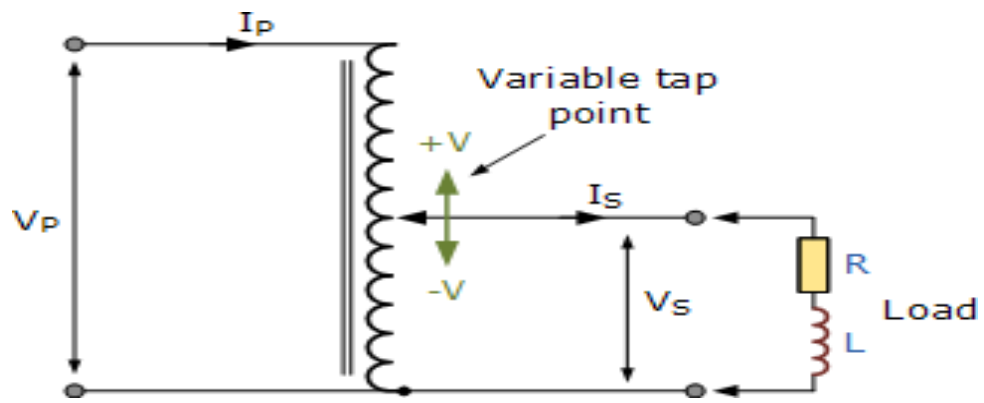

[Circuit Diagram of Single Phase Variac]

The structure theory of variac regulator:-

The auto coil of variac regulator is a coil of enameled wire tightly wound in the annular iron core. The coils are glued and fastened by insulating varnish, so the coils are insulated to each other. The circuit diagram as below. 220v AC electricity is input through the -a1 terminal and -b1 terminal and output through the -c1 terminal and -d1 terminal, and -c1 is the carbon brush touch point. It can be seen from the diagram that the carbon brush is contacting the polished surface of winding coils. Users can get the different voltages from 0v to 250v by means of moving the carbon brush contacting point.

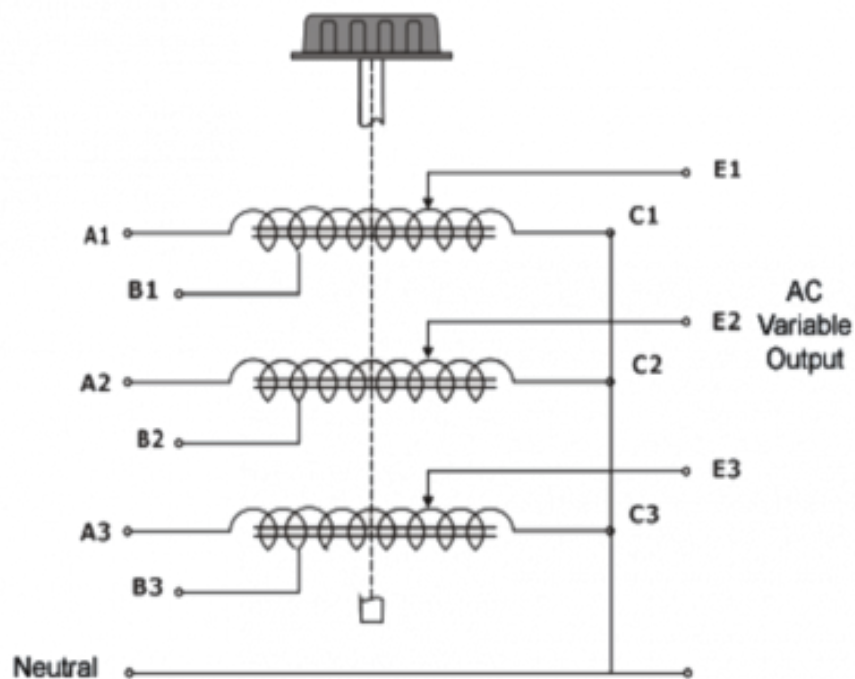

[Circuit Diagram of Three Phase Variac]

The failures of variac regulator:-

1. Poor contact of carbon brush

One possible cause is the carbon brush lead wire break-off or solder joint off due to long time usage. Just to reconnect and solder the wire, and the problem can be solved. The other possible cause is the screw loose between the rotating arm and the machine spin axis. In this condition, the spin axis spring will jack up the rotating

arm, and the carbon brush cannot contact the winding coils very well to give output voltage. In order to solve this problem, we need to reset the rotating arm to the appropriate location and tighten the screw.

It is found in repair that poor contact is usually caused by the situation that the small spring pressing the carbon brush lost the elasticity because of over heat. And this is bad result of the lack of long time machine maintenance. There is a circular-arc-shaped screw fixed stop dog between the zero potential and the highest potential of the variac regulator auto winding coil. The function of the stop dog is to ensure that the carbon brush is moving always between -el and -fl. It is very common that the stop dog gets loose and dislocated after long time use without maintenance.

But the consequences can be very serious. There is some current in the circuit when the machine is working with loading, and it equals to breaking off the loading if the carbon brush is moving beyond the highest potential, but the current in the conductance coil cannot change abruptly, which will inevitably result in arch discharging between the carbon brush and coil ends and very high temperature. Gradually the spring will lose elasticity and even the end coil gets burnt.

To solve this problem, it is needed to stick the stop dog with insulation tape firstly, and then fix it with screw to avoid dislocation or loosen-up. This will make sure that the carbon brush cannot move beyond the winding ends. Also, the broken spring must be changed and the burnt winding must be renewed.

2. Part coils of the winding get burnt

The burning of part coils is caused by the machine production quality, that is to say, there is

—wire jumping on the sliding surface of winding. And this will lead to larger voltage difference between the adjacent two coils. When the carbon brush passes the —wire jumping point, there will be a sudden change for the machine output voltage. The —wire jumping point is not the usual working place for carbon brush, therefore there is not big influence for the machine normal performance as carbon brush passes it very quickly.

However, if the output voltage requires the carbon brush to stay at the -wire jumping point for a long time, the machine failure is inevitable. This is because the voltage difference is large between the adjacent two coils, and there will be a large short-circuit current when carbon brush contacts these two coils. Consequently, the part coils will get heated, and copper loss gets bigger, the temperature becomes higher

then to form a vicious circle. In the course of time, the coils must get burnt.

As for this problem, we need to remove the burnt coils and replace with the same size varnished wire, and no more -wire jumping|. And then stick and fasten the coils with insulating varnish, and polish the sliding surface.

Procedure:-

- a) When taking maintenance or repair, firstly we should open the shell and dismantle all the parts to place them bysort.
- b) Wipe off the dust and carbon on the coils alcohol cotton ball.
- c) Clean every corner.
- d) Rub down the carbon brush that gets wider due to abrasion with a fine grade sandpaper, and re-install it for usage. Or change a new carbon brush if it is too broken for using.
- e) Repair and maintain the rough sliding surface to make sure the carbon brush can move smoothly.
- f) Check if the lead wire screws are loose, and if the lead wire is tipping off.

Conclusion: - From the above experiment we learnt about the overhaul of a single phase variac.