

**LECTURE NOTE**  
**ON**  
**THERMAL ENGINEERING (TH-4)**  
**4<sup>TH</sup> SEMESTER MECHANICAL (DIPLOMA COURSE)**



**PREPARED BY:**

**RUTUPARNA SWAIN**

**LECTURER IN MECHANICAL**

**GOVERNMENT POLYTECHNIC JAJPUR**

**UNDER STATE COUNCIL AND VOCATIONAL TRAINING, BHUBANESWAR, ODISHA**

---

## THERMAL ENGINEERING - II

---

<b>CONTENTS</b>		
<b>Sl. No.</b>	<b>Topic</b>	<b>Page no</b>
<b>1</b>	<b>PERFORMANCE OF IC ENGINE</b>	<b>2-6</b>
<b>2</b>	<b>AIR COMPRESSOR</b>	<b>6-13</b>
<b>3</b>	<b>PROPERTIES OF STEAM</b>	<b>13-22</b>
<b>4</b>	<b>STEAM GENERATOR</b>	<b>22-35</b>
<b>5</b>	<b>STEAM POWER CYCLE</b>	<b>35-43</b>
<b>6</b>	<b>HEAT TRANSFER</b>	<b>44-48</b>

# THERMAL ENGINEERING - II

## CH-1 (PERFORMANCE OF IC ENGINE)

### Engine:

- ▣ An engine is a device which transforms one form of energy into another form.
- ▣ However, while transforming energy from one form to another, the efficiency of conversion plays an important role.
- ▣ Normally, most of the engines convert thermal energy into mechanical work and therefore they are called 'heat engines'.

### Heat Engine:

- ▣ Heat engine is a device which transforms the chemical energy of the fuel into thermal energy and utilizes this thermal energy to perform useful work.
- ▣ Thus, thermal energy is converted to mechanical energy in a heat engine.
- ▣ Heat engines can broadly be classified into two categories
  - i) Internal combustion engine (IC engine)
  - ii) External combustion engine (EC engine)

### Basics of IC Engine:

- ▣ Internal combustion engines are those in which combustion takes place inside the engine cylinder.

Let, D = Bore; L = stroke

$V_1$  = Total volume of the cylinder

or  $V_c$  = Clearance volume

$V_s$  = Displacement volume =  $A \times L$  (A = piston area)

TDC = Top dead centre

BDC = Bottom dead centre

$$\begin{aligned}V_1 &= V_s + V_c \\V_2 &= V_c \\V &= \frac{\pi}{4} D^2 L\end{aligned}$$

- ▣ **Compression Ratio (r):** It is defined as the ratio of volume before compression to the volume after compression.

$$\begin{aligned}r &= \frac{V_1}{V_2} \\&= \frac{V_s + V_c}{V_c} \\&= \frac{V_s}{V_c} + 1\end{aligned}$$

### Engine Performance Parameter:

- ▣ Engine performance is indicated by the term efficiency,  $\eta$ . Five important efficiencies and related engine performance parameters are:
  - i. Indicated thermal efficiency

## ii. Brake thermal efficiency

# THERMAL ENGINEERING - II

# THERMAL ENGINEERING - II

- iii. Mechanical efficiency
- iv. Relative efficiency or efficiency ratio
- v. Volumetric efficiency
- vi. Mean effective pressure
- vii. Mean piston speed
- viii. Specific power output
- ix. Specific fuel consumption
- x. inlet-valve Mach Index
- xi. Fuel-air or air-fuel ratio
- xii. Calorific value of the fuel

## Indicated Mean Effective Pressure ( $P_{im}$ ):

- Mean effective pressure is the average pressure inside the engine cylinder of an internal combustion engine based on the calculated or measured power output.

$$P_{im} = \frac{\text{Net work of cycle}}{V_1 - V_2}$$

$$= \frac{\text{Area of the indicator diagram}}{\text{Length of the indicator diagram}}$$

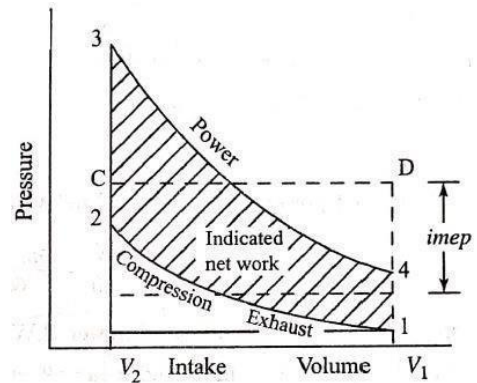

## Indicated Power (ip):

(Power is defined as rate of doing work)

- Indicated power is the power produced by the engine.

$$ip = \frac{P_{im} V_s n k}{60} \text{ W}$$

$$ip = \frac{P_{im} V_s n k}{60000} \text{ kW}$$

OR

$$ip = \frac{P_{im} L A n k}{60} \text{ W}$$

$$ip = \frac{P_{im} L A n k}{60000} \text{ kW}$$

Where,

ip=indicated power (W or kW)

$P_{im}$ = indicated mean effective pressure  $L = \frac{N}{\text{length of the stroke (m)}}$

(m<sup>2</sup>)

## THERMAL ENGINEERING - II

# THERMAL ENGINEERING - II

A = area of the piston(m<sup>2</sup>)

N = speed in rpm

n = number of power strokes per minute

$$= \frac{N}{2} \text{ (for four stroke engine)}$$

$$= N \text{ (for two stroke engine)}$$

K = number of cylinders

## Brake Power (bp):

- It is the power available at the engine shaft
- The brake power of an I.C. engine is usually measured by means of brake mechanism (prony brake or rope brake).

a) In case of prony brake,

Let,  $W$  = brake load (N)

$l$  = length of arm (m)

$N$  = speed of the engine in rpm

$$bp = \frac{\text{Torque in Nm} \times \text{Angle turned through one revolution}}{60} \times \text{rpm (Watt)}$$

$$bp = \frac{T \times 2\pi N}{60} \text{ Watt}$$

Or  $bp = \frac{W \times l \times 2\pi N}{60} \text{ Watt} \quad [\because T = W \times l]$

b) In case of rope brake,

Let,  $W$  = Dead load (N)

$S$  = spring balance reading (N)

$D$  = diameter of brake drum (m)

$d$  = diameter of rope (m)

$N$  = speed of the engine in rpm

$$bp = \frac{(W-S) \times \pi D N}{60} \text{ Watt (neglecting diameter of wire rope)}$$

$$bp = \frac{(W-S) \times \pi (D+d) N}{60} \text{ Watt (considering diameter of wire rope)}$$

- Brake power is less than indicated power.

## Frictional Power (fp):

- It is the part of indicated power which is used to overcome the frictional effects within the engine.
- The friction power also includes power required to operate the fuel pump, lubricating pump, valves, etc.
- Therefore, it is given as the difference between the indicated power and brake power.

- Mathematically,

$$ip = bp + fp$$

$$fp = ip - bp$$

## Specific Fuel Consumption (s.f.c.)

## THERMAL ENGINEERING - II

- The fuel consumption characteristics of an engine are generally expressed in terms specific fuel consumption in kilogram of fuel per kilowatt-hour.

$$sfc = \frac{\text{Fuel consumption per unit time}}{\text{power}} \quad \left( \frac{\text{kg/hr}}{\text{kW}} \right)$$

i. *Indicated Specific Fuel Consumption (isfc):*

$$isfc = \frac{\text{Mass of fuel consumption per unit time}}{\text{indicated power}} \quad \left( \frac{\text{kg/hr}}{\text{kW}} = \frac{\text{kg}}{\text{kWh}} \right)$$

ii. *Brake specific fuel consumption (bsfc):*

$$bsfc = \frac{\text{Mass of fuel consumption per unit time}}{\text{Brake power}} \quad \left( \frac{\text{kg}}{\text{kWh}} \right)$$

### Air-Fuel Ratio or Fuel-Air Ratio (A/F OR F/A):

- The relative proportions of the fuel and air in the engine are very important from the standpoint of combustion and the efficiency of the engine.
- This is expressed either as a ratio of the mass of the fuel to the air or vice versa.

Mathematically,

$$\frac{F}{A} = \frac{\text{Mass of fuel}}{\text{Mass of air}}$$

Or

$$\frac{A}{F} = \frac{\text{Mass of air}}{\text{Mass of fuel}}$$

### Calorific Value (CV):

- Calorific value of a fuel is the thermal energy released per unit quantity of the fuel when the fuel is burnt completely and the product of combustion are cooled back to initial temperature of the combustible mixture.

### Mechanical Efficiency ( $\eta_m$ ):

- Mechanical efficiency is defined as the ratio of brake power (delivered power) to the indicated power (power provided to the piston).
- (Or) It can be defined as the ratio of the brake thermal efficiency to the indicated thermal efficiency.

$$\eta_m = \frac{bp}{ip} = \frac{bp}{bp + ip}$$

### Indicated Thermal Efficiency ( $\eta_{ith}$ ):

- Indicated thermal efficiency is the ratio of energy in the indicated power, ip, to the input fuel energy in appropriate unit.

$$\eta_{ith} = \frac{ip \text{ [kJ/s]}}{\text{energy in fuel per second [kJ/s]}}$$

$$\eta_{ith} = \frac{\text{mass of fuel}}{s} \times \frac{ip}{\text{calorific value of fuel}}$$



# THERMAL ENGINEERING - II

$$\eta_{ith} = \frac{ip}{\dot{m} \times CV}$$

Where,  $\dot{m}$  = mass flow rate of the fuel (kJ/s)

## Brake Thermal Efficiency:

- It is the ratio of energy in the brake power bp, to the input fuel energy in appropriate unit.

$$\eta_{bth} = \frac{bp}{\frac{\text{Mass of fuel}}{s} \times \text{calorific value}}$$

$$\eta_{bth} = \frac{bp}{\dot{m} \times CV}$$

## Relative Efficiency:

- Relative efficiency or efficiency ratio is the ratio of the thermal efficiency of an actual cycle to that of the ideal cycle.
- The efficiency ratio is very useful criterion which indicates the degree of development of the engine.

$$\eta_{rel} = \frac{\text{Actual thermal efficiency}}{\text{air - standard efficiency}}$$

## Overall Efficiency:

- It is the ratio of work obtained at the crankshaft in a given time to the energy supplied by the fuel during the same time.
- Energy supplied by the fuel per minute =  $\frac{m_f \times CV}{60}$  (kJ)

Where,

$m_f$  = mass of fuel consumed in kg per hour

$CV$  = calorific value of fuel in kJ/kg of fuel

- Work obtained at the crankshaft per minute =  $bp \times 60$  (kJ) ( $\because bp$  is in kW)

$$\therefore \text{Overall efficiency, } \eta_o = \frac{bp \times 3600}{m_f \times CV}$$

## CH-2 (AIR COMPRESSOR)

- An air compressor is a machine which takes in atmospheric air, compresses it with the help of some mechanical energy and delivers it at high pressure.
- An air compressor increases the pressure of air by decreasing its specific volume using mechanical means.
- The controlled expansion of compressed air provides motive force in air motors, pneumatic hammer, air drills, sand blasting machines and paint sprayers etc.

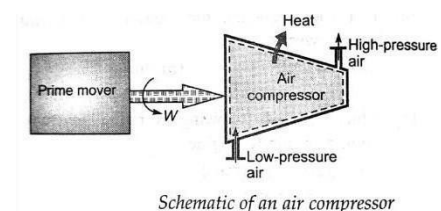

## Uses of compressed air:

Compressed air has wide application in industries as well as in commercial equipments. It is used in:

# THERMAL ENGINEERING - II

- i. Air refrigeration and cooling of large buildings
- ii. Driving pneumatic tools in shops like drills, riveters, screw drivers, etc.
- iii. Driving air motors in mines, where electric motors and IC engine cannot be used because of fire risks due to the presence of inflammable gas, etc.
- iv. Cleaning purpose
- v. Blast furnace
- vi. Spray painting and spraying fuel in diesel engine
- vii. Hard excavation work, tunnelling, boring, mining, etc
- viii. Starting of heavy duty diesel engine
- ix. Operating air brakes in buses, trucks, etc
- x. Inflating automobile tyre

## Classification:

The compressors are mainly classified as

- i. Reciprocating compressor
- ii. Rotary compressor

The air compressors can broadly be classified as

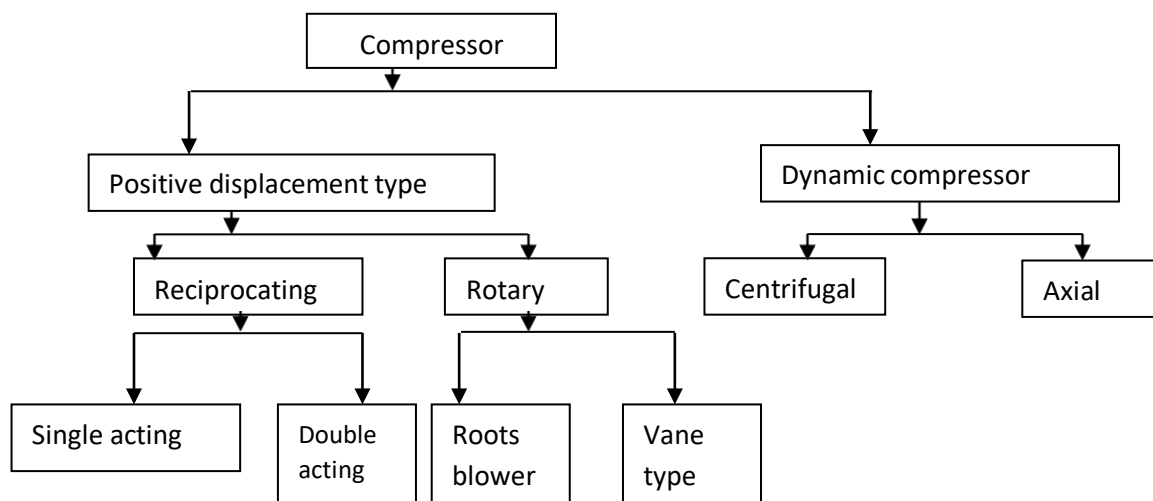

- A reciprocating compressor is used to produce high pressure gas. It uses displacement of piston in the cylinder for compression. It handles a low mass of gas and high pressure ratio.
- The rotary compressors are used for low and medium pressure. They usually consist of a blade wheel or impeller that spins inside a circular housing. They handle a large mass of gas.
- These compressors may be single stage or multistage to increase the pressure ratio.

## Reciprocating compressor terminology

### i. Single acting compressor:

- It is a compressor used in which suction, compression and delivery of a gas take place only on one side of the piston during cycle of one revolution of the crank shaft.

### ii. Double acting compressor

# THERMAL ENGINEERING - II

- It is a compressor in which suction, compression, and delivery of gas takes place on both sides of the piston and two cycles take place during one revolution of crank shaft.

### iii. Single stage compressor:

- It is a compressor in which the compression of gas to final delivery pressure is carried out in one cylinder only.

### iv. Multistage compressor:

- It is a compressor in which the compression of gas to the final pressure is carried out in more than one cylinder in series.

### v. Pressure ratio:

- It is defined as the ratio of absolute discharge pressure to absolute suction pressure.

### vi. Compressor displacement volume:

- It is the volume created when the piston travels a stroke

$$V = \frac{\pi}{4} d^2 L$$

d = bore of the cylinder

L = stroke of the piston

### vii. Compressor capacity:

- It is the actual quantity of air delivered per unit time at atmospheric condition.

### viii. Free air delivered (FAD):

- It is the actual volume of air delivered by the compressor corresponding to atmospheric condition or ambient condition.

### ix. Piston speed:

- It is the linear speed of the piston measured in m/min. It is expressed as

$$V_{\text{piston}} = 2LN$$

### x. Volumetric efficiency:

- The ratio of actual volume of air sucked into the compressor, measured at atmospheric pressure and temperature to the piston displacement volume

### Reciprocating air compressor:

- Here pressure is increased by means of variation in the volume of cylinder obtained by a moving piston.

#### Construction:

- It consists of a piston, which reciprocates inside a cylinder with connecting rod and crank mechanism.
- There are inlet and delivery valves mounted in the head of cylinder.
- The inlet and delivery valves are of pressure differential type i.e. they operate as a result of pressure difference across the valves.

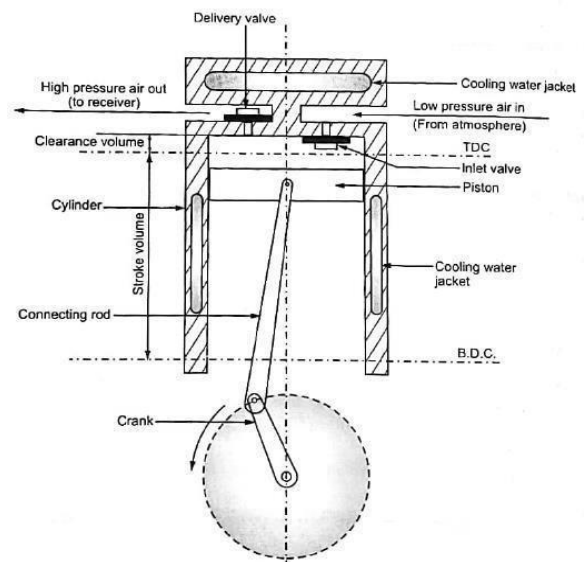

# THERMAL ENGINEERING - II

## **Working:**

Working of a single stage reciprocating air compressor completes in two strokes.

# THERMAL ENGINEERING - II

## a) Suction stroke:

- When the piston moves in the downward direction i.e. from top dead center (T.D.C.) to bottom dead center (B.D.C.), the air compressor in the previous compression and entrapped in the clearance space begins to expand.
- When the pressure inside the cylinder falls below the atmospheric pressure, the inlet valve gets opened, and air is sucked into the cylinder, till the piston reaches BDC. During the stroke, delivery valve remains closed.

## b) Compression stroke:

- Now the suction valve is closed and the piston starts moving from BDC to TDC. The pressure inside the cylinder goes on increasing upto the desired discharge pressure.
- At this stage, the delivery valve gets opened and compressed air is delivered into the receiver.
- At the end of compression stroke, a small quantity of air, at high pressure, is left in the clearance space.

➤ And

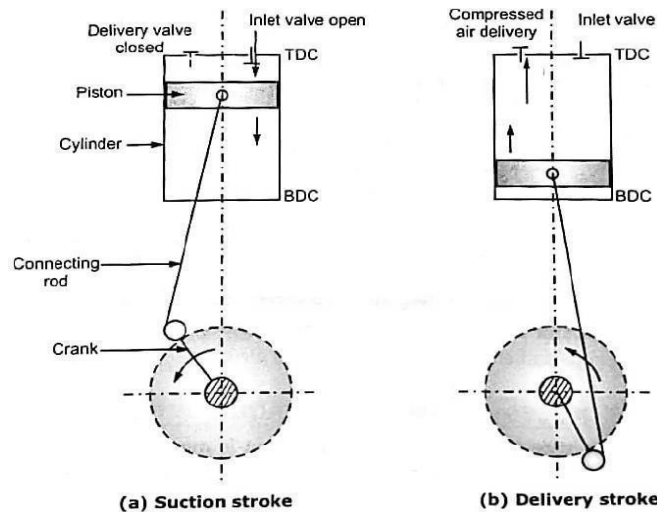

the cycle is repeated again and again.

### ❖ Net work input for single stage reciprocating air compressor without clearance volume: Process c-1:

Inlet valve opens and air enters the compressor at constant pressure  $P_1$ . **Process 1-2:** Polytropic compression of air from pressure  $P_1$  to  $P_2$ .

**Process 2-d:** Discharge of compressed air through delivery valve at constant pressure  $P_2$ .

**Process d-c:** Return of piston for suction stroke. Work done on air per cycle,

$W =$  Area behind the curve, i.e., area c-1-2-d-c

$$= \text{Area } 2-d-o-b-2 + \text{Area } 1-2-b-a-1 - \text{Area } 1-c-o-a-1$$

$$W = P_1 V_1 + \frac{P_2 V_2}{2} - \frac{P_1 V_1}{2}$$

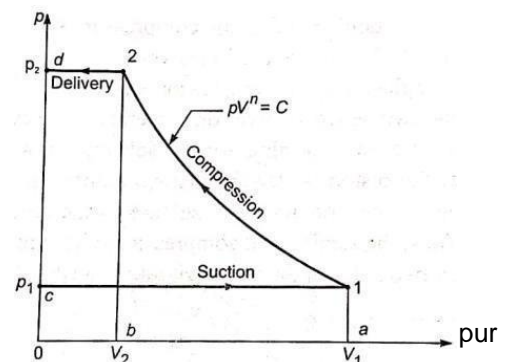

# THERMAL ENGINEERING - II

$n-1$

# THERMAL ENGINEERING - II

$$W = (P_2V_2 - P_1V_1) \left[ \frac{1}{n-1} - 1 \right]$$

$$W = \frac{n}{n-1} (P_2V_2 - P_1V_1) \text{ (KJ/cycle)} \dots\dots\dots(i)$$

Using characteristic gas equation as  $PV = m_aRT$

$$P_1V_1 = m_aRT_1$$

$$P_2V_2 = m_aRT_2$$

$$W = \frac{n}{n-1} m_aR(T_2 - T_1) \text{ (KJ/cycle)} \dots\dots\dots(ii)$$

$$W = \frac{n}{n-1} m_aRT_1 \left( \frac{T_2}{T_1} - 1 \right)$$

$$W = \frac{n}{n-1} m_aRT_1 \left[ \left( \frac{P_2}{P_1} \right)^{\frac{n-1}{n}} - 1 \right] \text{ (KJ/cycle)} \quad [\because \text{For } 1-2 \quad \frac{T_2}{T_1} = \left( \frac{P_2}{P_1} \right)^{\frac{n-1}{n}}]$$

$$W = \frac{n}{n-1} P_1V_1 \left[ \left( \frac{P_2}{P_1} \right)^{\frac{n-1}{n}} - 1 \right] \text{ (KJ/cycle)}$$

Where  $V_1$  is volume induced per cycle

**Minimizing compression work :**

- ☐ The work done on the gas for compression can be minimized when the compression process is executed in an internally reversible manner, i.e. by minimizing irreversibilities.
- ☐ The other way of reducing the compression work is to keep the specific volume of gas as small as possible during compression. Since specific volume of gas is proportional to temp., therefore the cooling arrangement is provided on the compressor to cool the gas during the compression.
- ☐ For better understanding of the effect of cooling during compression process, we consider three types of compression process executed between same pressure levels ( $P_1$  and  $P_2$ ) an isentropic compression 1-2'' (involves no cooling), a polytropic compression 1-2 (involves partial cooling) and an isothermal compression 1-2' (involves perfect cooling) as shown in figure below:

**a) Polytropic compression process 1-2**

$$W_{poly} = \frac{n}{n-1} P_1V_1 \left[ \left( \frac{P_2}{P_1} \right)^{\frac{n-1}{n}} - 1 \right]$$

**b) Isentropic compression process 1-2**

An equation for work input can be obtained by replacing  $n$  by  $\gamma$

$$W_{isentropic} = \frac{\gamma}{\gamma-1} P_1V_1 \left[ \left( \frac{P_2}{P_1} \right)^{\frac{\gamma-1}{\gamma}} - 1 \right]$$

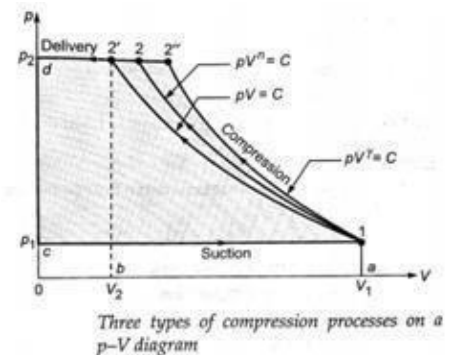

# THERMAL ENGINEERING - II

## c) Isothermal compression process 1-2' [with perfect cooling ( $T_2=T_1$ )] Work

input for isothermal compression is given by area c-1-2'-d-c  $W_{\text{isothermal}} = \text{Area c-1-2'-d-c}$

$1-2'-d-c = \text{Area a-1-2'-b} + \text{Area b-2'-d-o} - \text{Area a-1-c-o}$

$$W_{\text{isothermal}} = P_1 V_1 \ln \left( \frac{V_1}{V_2} \right) + P_2 V_2 - P_1 V_1$$

For isothermal process  $P_2 V_2 = P_1 V_1$  and  $\frac{V_1}{V_2} = \frac{P_2}{P_1}$

$$W_{\text{isothermal}} = P_1 V_1 \ln \frac{P_2}{P_1}$$

Note: It is observe from the above diagram that among the three process considered, the areawith isentropic compression is maximum and the area with isothermal compression is maximum. Thus isentropic compression requires maximum work and isothermal compression requires minimum work.

### Power required to drive a single stage reciprocating air compressor:

$$P = \frac{W N_w}{60} \text{ watt}$$

$N_w =$  number of working stroke per minute

If  $N$  is the speed of the compressor in r.p.m., then  $N_w = N$  (For single acting compressor)

$N_w = 2N$  (For double acting compressor)

### Clearance volume in a compressor:

The clearance volume is the space left in the cylinder when the piston reaches its top most position, TDC. It is provided

- I. To avoid the piston striking the cylinder head
- II. To accommodate the valve's actuation inside the cylinder, because suction and delivery valves are located in the clearance volume.

### Effect of clearance volume:

- The volume of air taken in per stroke is less than the swept volume, thus the volumetric efficiency decreases.
- More power input is required to drive the compressor for same pressure ratio, due to increase in volume to be handled.
- The maximum compression pressure is controlled by the clearance volume.

### Work done by Reciprocating Air Compressor with Clearance volume:

The work done is given by the area 1-2-3-4-1 on a P-V diagram Work

done = Area 1-2-3-4-1 = Area 1-2-e-d - Area 3-e-d-4

The compression work equivalent to area 1-2-e-d with index of compression  $n_c$

$$W_{\text{comp}} = \frac{n_c}{n_c - 1} P_1 V_1 \left[ \left( \frac{P_2}{P_1} \right)^{\frac{n_c - 1}{n_c}} - 1 \right]$$

The work done by gas during expansion (index  $n_e$ ) = Area 3-e-d-4,

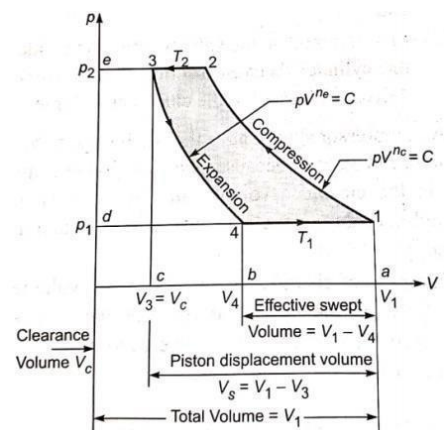



# THERMAL ENGINEERING - II

$$W_{\text{Expn}} = \frac{n_e}{n_e - 1} P_4 V_4 \left[ \left( \frac{P_3}{P_4} \right)^{\frac{n_e - 1}{n_e}} - 1 \right]$$

$$= \frac{-e}{n_e - 1} P_1 V_4 \left[ \left( \frac{P_3}{P_1} \right)^{\frac{n_e - 1}{n_e}} - 1 \right]$$

Since  $P_4 = P_1$  &  $P_3 = P_2$  Net

work of compression;

$$W = \frac{n_c}{n_c - 1} P_1 V_1 \left[ \left( \frac{P_2}{P_1} \right)^{\frac{n_c - 1}{n_c}} - 1 \right] - \frac{n_e}{n_e - 1} P_1 V_4 \left[ \left( \frac{P_2}{P_1} \right)^{\frac{n_e - 1}{n_e}} - 1 \right]$$

If indices of compression and expansion are same, i.e.  $n_c = n_e = n$  then

$$W_{\text{in}} = \frac{P_1 (V_1 - V_4)}{n - 1} \left[ \left( \frac{P_2}{P_1} \right)^{\frac{n - 1}{n}} - 1 \right]$$

### Multistage compression:

The compression of air in two or more cylinders in series is called multistage compression

#### Advantages:

- The gas can be compressed to a sufficiently high pressure
- Cooling of air is more efficient with intercoolers and cylinder wall surfaces.
- It improves the volumetric efficiency for the given pressure ratio.
- It reduces leakage loss considerably.
- The work done per kg air is reduced in multistage compression with intercoolers as compared

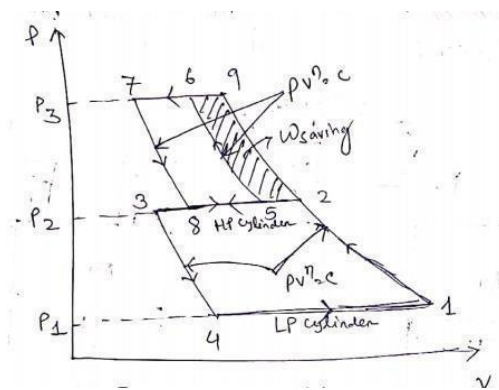
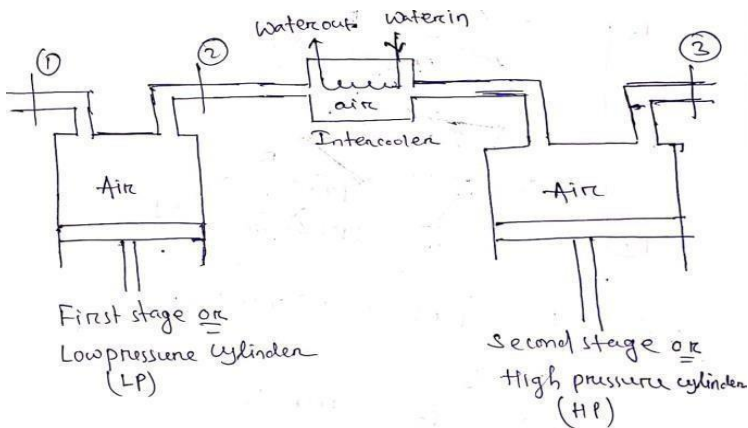

to single stage compression for the same

delivery pressure.

### Net work input for 2 stage single acting reciprocating air compressor with intercooler:

#### Condition for perfect intercooler:

$$T_1 = T_5$$

# THERMAL ENGINEERING - II

$$P_1 V_1 = P_5 V_5 = mRT_1$$

$$P_1(V_1 - V_4) = P_5(V_5 - V_8) = mRT_1$$

Assuming perfect intercooling,

$$W_{\text{net,2stage}} = W_{L,P} + W_{H,P}$$

$$W_{\text{net,2stage}} = \left(\frac{n}{n-1}\right) P_1(V_1 - V_4) \left[\left(\frac{P_2}{P_1}\right)^{\frac{n-1}{n}} - 1\right] + \left(\frac{n}{n-1}\right) P_5(V_5 - V_8) \left[\left(\frac{P_3}{P_2}\right)^{\frac{n-1}{n}} - 1\right]$$

$$= \left(\frac{n}{n-1}\right) mRT_1 \left[\left(\frac{P_2}{P_1}\right)^{\frac{n-1}{n}} - 1\right] + \left(\frac{n}{n-1}\right) mRT_1 \left[\left(\frac{P_3}{P_2}\right)^{\frac{n-1}{n}} - 1\right]$$

$$W_{\text{net,2stage}} = \left(\frac{n}{n-1}\right) mRT_1 \left[\left(\frac{P_2}{P_1}\right)^{\frac{n-1}{n}} + \left(\frac{P_3}{P_2}\right)^{\frac{n-1}{n}} - 2\right]$$

$P_1$  = Inlet pressure

$P_3$  = Delivery pressure

$P_2$  = Intermediate pressure

## CH-3 (PROPERTIES OF STEAM)

### Pure substance:

- A substance that has a fixed composition throughout is called a pure substance.  
Example: Water, Nitrogen, Helium & Carbon dioxide, etc.
- However, a pure substance doesn't have to be of a single chemical element or compound. A mixture qualifies as a pure substance as long as the mixture is homogeneous.  
Example: Air is a pure substance, But a mixture of oil and water is not a pure substance.
- A mixture of two or more phases of a pure substance is still a pure substance as long as the chemical composition of all phases is the same.  
Example: A mixture of ice and liquid water is a pure substance. But mixture of liquid air and gaseous air is not a pure substance.

### Phases of a pure substance:

- A phase is identified as having a distinct molecule arrangement that is homogeneous throughout and separated from the other by easily identifiable boundary surfaces.
- Three principal phases of a pure substance are: solid, liquid and gas.

### Formation of steam at constant pressure:

- Consider a cylinder fitted with a frictionless piston, which may be loaded to any desired pressure.

## THERMAL ENGINEERING - II

- The cylinder contains 1 kg of ice at  $-10^{\circ}\text{C}$  under 1 atm pressure at the state A.

# THERMAL ENGINEERING - II

- The stages of heat addition at constant pressure (1atm) are shown in the above figure.

## Process A-B:

- When any amount of heat is added to ice, it gets warmer and its temperature rises till it approaches  $0^\circ$  as shown by line AB in the above figure.

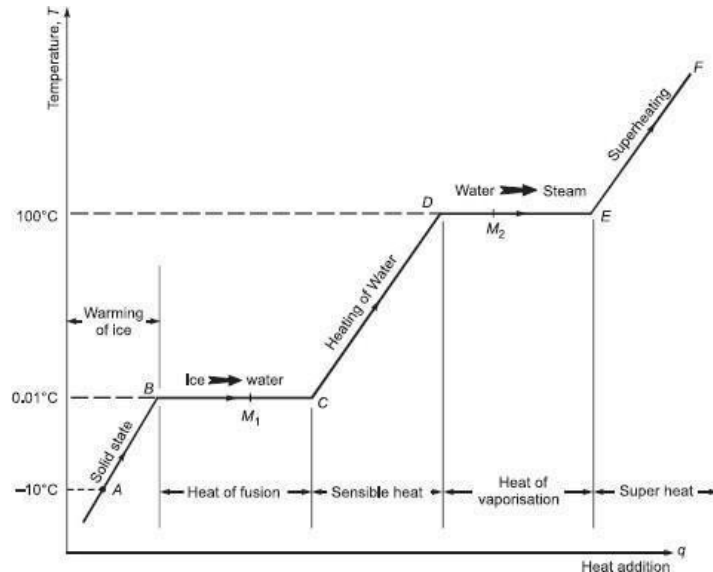

## Process B-C:

- The following facts are observed during this process:
- Ice begins to melt at  $0^\circ\text{C}$  and a two-phase mixture is formed.
- The temperature of the two-phase mixture ( $M_1$ ) of ice and water does not change on heat addition as it is shown by the line BC.
- There is slight decrease in volume because the liquid water at  $0^\circ\text{C}$  is heavier than ice.
- At the point C, all ice melts to water without change in pressure (1 atm) and temperature ( $0^\circ\text{C}$ ).
- This phase transformation from solid to liquid is called the melting or fusion of ice.

## Process C-D:

- When heat is added to liquid water, the following facts are observed:
- The temperature of water rises with heat supply and keeps on rising until it reaches boiling point temperature, the point D.

## Process D-E:

- After water reaches saturation temperature (i.e.,  $100^\circ\text{C}$  at 1 atm), any addition of heat will cause some liquid to vaporize at the same temperature. This is again a phase-change process from saturated water to saturated vapor. During this phase-change process, the following facts are observed:
- There exists a two-phase mixture  $M_2$  of water and vapor, called the wet steam.
- The temperature of the mixture remains constant until all water does not convert in to vapor (steam).
- The process of phase change takes place at constant temperature and constant pressure.
- The specific volume of vapor is considerable larger than that of saturated water.

# THERMAL ENGINEERING - II

- At the state E, all the water has been vaporized and this state of steam is called dry and saturated steam. The phase change from liquid to vapor is called vaporization.

## Process E-F:

- Once the phase change is completed, we are back to single phase region again (vapor phase), and further transfer of heat results in an increase in both temperature and specific volume. This vapor is called superheated vapor.

## Note:

- Compressed liquid or subcooled liquid: A liquid that is not about to vaporize or liquid existing at a temperature lower than saturation temperature.
- Saturated liquid: A liquid that is about to vaporize is called saturated liquid.
- Saturated vapor: A vapor that is about to condense is called a saturated vapor.
- Superheated vapor: A vapor that is not about to condense is called a superheated vapor.

## Relation between pressure and temperature for pure substance (H<sub>2</sub>O):

- The temperature at which water starts boiling depends on the pressure; therefore, if the pressure is fixed, so is the boiling temperature.
- At a given pressure, the temperature at which a pure substance changes phase is called the saturation temperature ( $T_{sat}$ ).
- At a given temperature, the pressure at which a pure substance changes phase is called the saturation pressure ( $P_{sat}$ ).

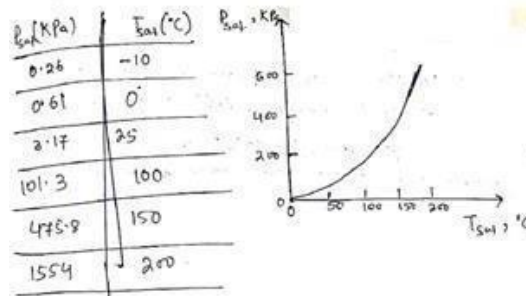

## Note:

- Latent heat: It is the amount of heat transfer required to cause a phase change in unit mass required to cause a phase change in unit mass of a substance at a constant pressure and temperature.
- Latent heat of fusion ( $l_{fu}$ ): It is the amount of heat transferred to melt unit mass of solid into liquid or to freeze unit mass of liquid to solid.
- Latent heat of vaporization ( $l_{vap}$ ): It is the quantity of heat required to vaporize unit mass of liquid into vapor or condense unit mass of vapor into liquid.
- Latent heat of sublimation ( $l_{sub}$ ): It is the amount of heat transferred to convert unit mass of solid to vapor or vice versa.
- $l_{fu}$  is not much affected by pressure, whereas  $l_{vap}$  is highly sensitive to pressure.

## T-V diagram:

# THERMAL ENGINEERING - II

- Let's do the process of phase transformation from liquid water to vapour at different pressures.
- At different pressures, the path followed by liquid to vapour phase change are shown in the figure.

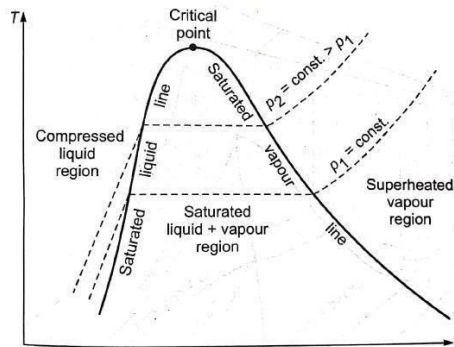

- As pressure increases, the saturation temperature  $T_{\text{sat}}$  for boiling and condensation also increases.
- As pressure increases, the specific volume of saturated liquid increases slightly, while the specific volume for saturated vapour decreases considerably, thus the saturation line on the  $T-v$  diagram will continue to get shorter.
- All saturated liquid states are connected by a solid line, called the saturated liquid line.
- All saturated vapour states are connected by another solid line, called the saturated vapour line.
- The saturated liquid line and saturated vapour line meet at the critical point and form a dome as shown.
- The region located left to the saturated liquid line is called the compressed liquid region.
- The region located right to the saturated vapour line is called the superheated vapour region.
- The substance can exist in the single phase only in the compressed liquid or superheated vapour region as a liquid or a vapour.
- The region under the dome involves equilibrium between saturated liquid and saturated vapour, and is called the wet vapour region.

## p-v diagram:

- The overall shape of a  $p-v$  diagram of a pure substance is very similar to a  $T-v$  diagram, except that the constant temperature lines on this diagram have a downward trend.
- The pressure-specific volume ( $p-v$ ) diagram for water is shown in the figure.
- It is evident from a  $p-v$  diagram, as pressure of a pure substance decreases at constant temperature, the specific volume of liquid increases marginally, but the specific volume of vapour increases considerably.

## THERMAL ENGINEERING - II

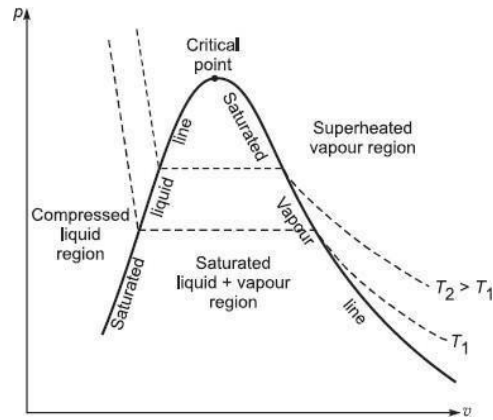

### Extending the diagram to include the solid phase:

- The  $p$ - $v$  diagrams discussed above represent the equilibrium states involving the liquid and vapour phases only.
- These diagrams can also be extended to include the solid phase as well as solid-liquid and solid-vapour saturation regions as shown.

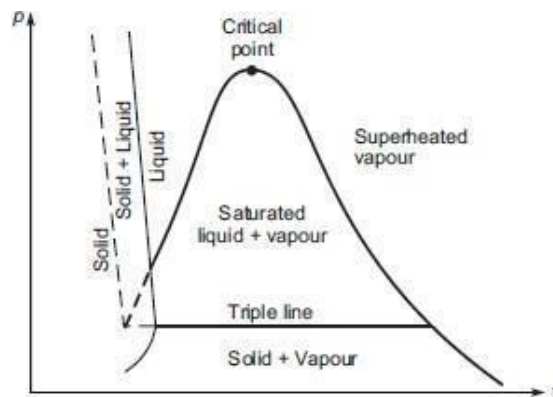

- All the three phases of a pure substance exist along a line, called the triple line. Along the triple line a substance has the same pressure and temperature, but different specific volumes.
- Since the water expands on freezing, therefore, a portion of the triple line is extended towards the left to the saturated liquid line.

### T-S diagram:

- The temperature-entropy ( $T$ - $s$ ) diagram of a pure substance is shown with the following observations.
- The absolute temperature data is plotted along the ordinate, and the specific entropy  $s$  is plotted along the abscissa.
- The value of specific entropy at triple point is zero, and thus the saturated liquid line originates at a temperature of 273.16 K.

## THERMAL ENGINEERING - II

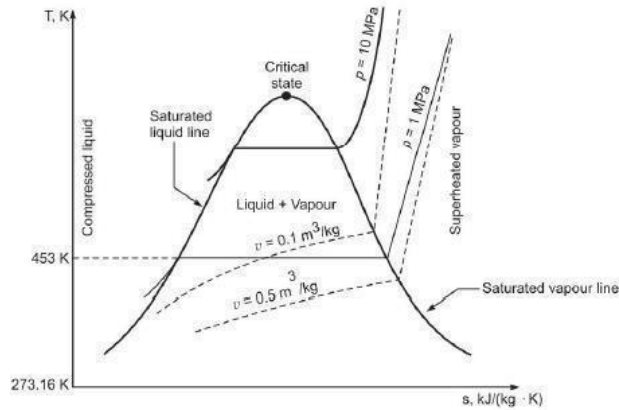

- The saturated liquid line and saturated vapour line divide the diagram into three regions, i.e., compressed liquid region left to the saturated liquid line, superheated vapour region right to the saturated vapour line and the wet vapour region between these two lines. The two saturation lines meet at the critical point.
- In the compressed liquid region, the constant-pressure lines almost coincide with the saturated liquid line.
- In the saturated liquid–vapour mixture region, the constant pressure lines and constant temperature lines are horizontal and parallel to each other.
- In the superheated vapour region, the constant volume lines are steeper than the constant pressure lines.

### h-s diagram or Mollier diagram for a pure substance:

$$\text{slope} = \frac{dy}{dx} = \frac{dh}{ds}$$

$$Tds = dh - vdp$$

$$\text{When } p = C, dp = 0$$

$$Tds = dh$$

$$\left(\frac{dh}{ds}\right)_p = T$$

- Slope of constant pressure line on h-s diagram represents temperature.
- h-s diagram of pure substance (Water) is called Mollier diagram.



# THERMAL ENGINEERING - II

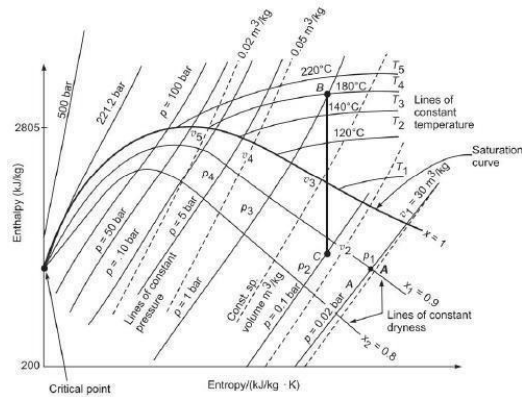

- In phase change process slope is constant since temperature is constant.
- In superheated region slope increases because temperature is increasing.
- Here, the constant pressure lines diverge from one another and the critical isobar is a tangent at the critical point.
- In the above h-s or Mollier diagram only the liquid and vapour phases are shown.

## Critical point:

- It is defined as the point at which the saturated liquid and saturated vapour states are identical.

## Critical point data for water:

$$P_{cr} = 22.06 \text{ MPa}$$

$$v_{cr} = 0.003106 \text{ m}^3/\text{kg}$$

$$T_{cr} = 373.95^\circ\text{C}$$

**Subcooling:** Cooling of liquid below saturation temperature. ( $T_{sat} > T$ )

**Degree of subcooling:**  $\circ T_{subcooling} = T_{sat} - T$

**Superheating:** Heating of vapour above saturation temperature. ( $T_{sat} < T_{sup}$ )

**Degree of superheating:**  $\circ T_{superheating} = T_{sup} - T_{sat}$

**Sensible heat:**  $Q = mc \circ T$

## Latent heat:

$$Q_p = dH(kJ)$$

$$q_p = dh \left( \frac{kJ}{kg} \right)$$

$$(q_p)_{f-g} = (dh)_{fg} = h_g - h_f = h_{fg} = LH$$

$$LH = h_g - h_f = h_{fg}$$

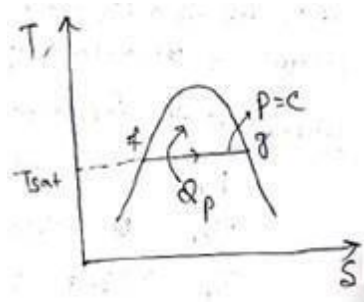

## Latent heat of vaporization:

# THERMAL ENGINEERING - II

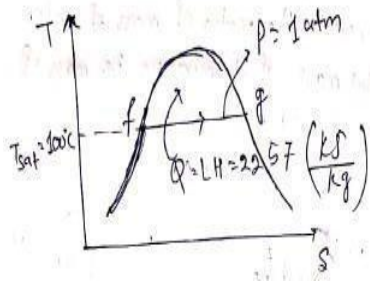

## Latent heat of condensation:

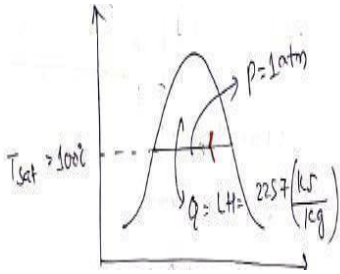

## Note:

- With increase in pressure latent heat of vaporization decreases.
- At critical point latent heat becomes zero.
- At critical point liquid water directly flashes into vapour.

## Dryness fraction or Quality of steam (x):

- It is defined as the ratio of mass of water vapour to the total mass of the mixture i.e, mass of vapour and mixture.

$$x = \frac{m_v}{(m_{total})_{mixture}} = \frac{m_v}{m_v + m_l}$$

Note:  $x = 0 \rightarrow$  saturated liquid,  $x$

$= 1 \rightarrow$  saturated vapour,

$0 < x < 1 \rightarrow$  saturated

liquid and vapour

## Specific volume of wet

$$m = m_v + m_l$$

$$V = v_v + v_l$$

$$V =$$

$$m$$

$$V = v \times m$$

$$V_v = v_v \times m_v$$

$$V_l = v_l \times m_l$$

$$V = V_v + V_l$$

$$V_m = v_v m_v + v_l m_l$$

$$V = \frac{v_v m_v}{m} + \frac{v_l m_l}{m}$$

$$V = \frac{v_v m_v}{m_v + m_l} + \frac{v_l m_l}{m_v + m_l}$$

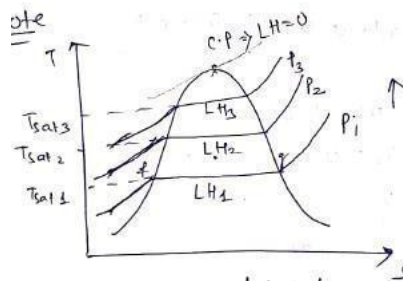

## steam:

# THERMAL ENGINEERING - II

$$V = v_v x + v(1 - x)$$

$$V = v_v x + v_l - x v_l$$

$$V = v_l + x(v_v - v_l)$$

**Enthalpy at various points:** Enthalpy at

**dry saturated steam:**  $h_g = h_f + \delta h$

$$h_g = h_f + (h_g - h_f) = h_f + h_{fg} =$$

$$h_f + LH$$

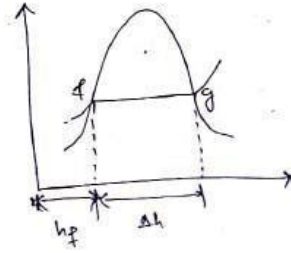

**Enthalpy of superheated steam:**

$$h_{sup-vap} = h_g + \delta h$$

$$h_{sup-vap} = h_g + C_{p,vap}(T_{sup} - T_{sat})$$

**Entropy at various points:**

Entropy change during phase transformation:

$$ds_{fg} = \left( \frac{\delta Q_{fg}}{T} \right)_{rev}$$

$$ds_{fg} = \frac{\delta q_{fg}}{T}$$

$$oS = \frac{LH}{T_{sat}}$$

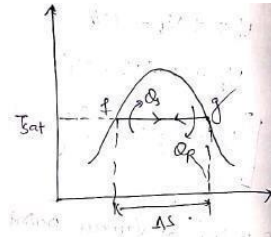

Entropy of dry saturated steam:

$$S_g = S_f + oS$$

$$S_g = S_f + \frac{LH}{T_{sat}}$$

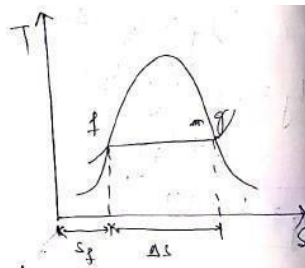

Entropy of superheated steam:

$$S_{superheated\ vap} = S_g + \delta S$$

$$= S_g + C_{p,vap} \ln \left( \frac{T_{sup}}{T_{sat}} \right)$$

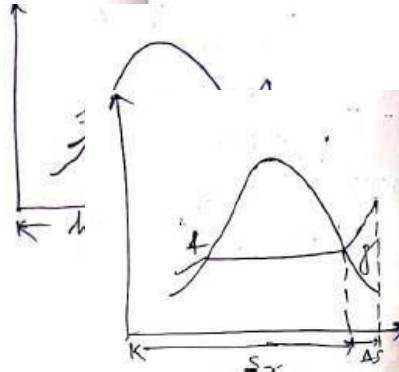

**Application of First law of TD in various Non-flow process:**

# THERMAL ENGINEERING - II

**Isochoric** ( $V = C$ ):

$$\delta Q = dU + \delta W$$

$$\therefore \delta W = 0$$

$$\therefore \delta Q = dU$$

**Isobaric** ( $P = C$ )  $\rightarrow P_1 = P_2 = P$

$$\delta Q = dU + \delta W$$

$$\delta Q = (U_2 - U_1) + (P_2 V_2 - P_1 V_1)$$

$$\delta Q = (U_2 - U_1) + P V_2 - P V_1$$

$$\delta Q = (U_2 + P_2 V_2) - (U_1 + P_1 V_1)$$

$$\delta Q = H_2 - H_1$$

$$\delta Q = dH$$

**Isothermal** ( $T = C$ ):

$$\delta Q = dU + \delta W$$

$$\therefore dU = 0$$

$$\therefore \delta Q = \delta W$$

**Adiabatic** ( $Q = 0$ )

Expansion :  $\delta W = \#$

Compression:  $dU =$

**$\delta W$  Polytropic:**

$$\delta Q = dU + \delta W$$

$$\delta Q = mc_v dT + \frac{p_1 v_1 - p_2 v_2}{n - 1}$$

$$\delta Q = \frac{m(T_2 - T_1)}{\gamma - 1} + \frac{p_1 v_1 - p_2 v_2}{n - 1}$$

$$\delta Q = \frac{(p_2 v_2 - p_1 v_1)}{\gamma - 1} + \frac{p_1 v_1 - p_2 v_2}{n - 1}$$

$$\delta Q = (p_1 v_1 - p_2 v_2) \left( -\frac{1}{\gamma - 1} + \frac{1}{n - 1} \right)$$

$$\delta Q = (p_1 v_1 - p_2 v_2) \left( \frac{-n + 1 + \gamma - 1}{(\gamma - 1)(n - 1)} \right)$$

$$\delta Q = \frac{(p_1 v_1 - p_2 v_2)}{n - 1} \times \frac{\gamma - n}{\gamma - 1}$$

$$\delta Q = \delta W_{poly} \times \frac{\gamma - n}{\gamma - 1}$$

Polytropic expansion:  $\delta W \rightarrow +ve$

$$\delta Q = \delta W_{poly} \times \frac{\gamma - n}{\gamma - 1}$$

If,  $n < \gamma = \delta Q = +ve = \delta Q_{supply}$

If,  $n > \gamma = \delta Q = -ve = \delta Q_{rejection}$

If,  $n = \gamma = \delta Q = zero = \text{adiabatic process}$

# THERMAL ENGINEERING - II

Polytropic compression:  $\delta W \rightarrow -ve$

If,  $n < \gamma = \delta Q = -ve = \delta Q_{rejection}$

If,  $n > \gamma = \delta Q = +ve = \delta Q_{supply}$

If,  $n = \gamma = \delta Q = zero = \text{adiabatic process}$

## CH-4 (STEAM GENERATOR)

- A steam generator or boiler is basically closed vessel into which water is heated until the water is converted into steam at required pressure.
- A boiler or steam generator is a device used to steam by applying heat to water.
- The heated or vaporized fluid exits the boiler for use in various process or heating application, including water heating, central heating, and boiler based power generation, cooking and sanitation.

### Important terms for steam boiler:

1. **Boiler shell:** It is made up of steel plates bent into cylinder form and riveted or welded together. The ends of the shell are closed by means of end plates. A boiler shell should have sufficient capacity to contain water and steam.
2. **Combustion chamber:** It is the shell generated below the boiler shell, meant for burning fuel in order to produce steam from the water contained in the shell.
3. **Grate:** It is a platform, in the combustion chamber, upon which fuel is burnt. The grate generally consists of cast iron bars which are spaced apart. So that air can pass through them. The surface area of the grate over which the fire takes place, is called grate surface.
4. **Furnace:** It is the space above the grate and below the boiler shell, in which the fuel is actually burnt.
5. **Heating surface:** It is the part of boiler surface, which is exposed to the fire (hot gases from the fire).
6. **Mounting:** These are fittings which are mounted on the boiler for its proper functioning. They include water level indicator, pressure gauge, safety valve etc.
7. **Accessories:** These accessories are mounted on the boiler to increase its efficiency.
  - i. Superheater,
  - ii. Economiser etc

### Boiler classification:

There are large numbers of boiler design, but they may be classified according to the following criteria.

#### 1. According to the relative passage of water and hot gases:

- a) **Water tube boiler:** A boiler in which the water flows through a number of small tubes which are surrounded by hot combustion gases.  
Ex: Babcock and Wilcox, Stirling, Benson boiler etc.
- b) **Fire tube boiler:** The hot combustion gases pass through the boiler tubes, which are surrounded by water.

# THERMAL ENGINEERING - II

Ex: Lancashire, Cochran, Locomotive boiler etc

## 2. According to the water circulation arrangement:

- a) **Natural circulation:** Water circulates in the boiler due to density difference of hot and cold water. Ex: Babcock and Wilcox boiler, Lancashire boiler and Locomotive boiler etc.
- b) **Forced circulation:** A water pump forces the water along its path therefore the steam generation rate increases.

Ex: Benson, LaMont, Velox boiler etc

## 3. According to the use:

- a) **Stationary boiler:** These boilers are used for power generation in thermal power plants or process steam in plants.
- b) **Portable boiler:** These are small units of mobile boiler and are used for temporary uses at the sites.
- c) **Locomotive:** These are specially designed boilers. They produce steam to drive railway engines.
- d) **Marine boiler:** These are used on ships.

## 4. According to the position of the boiler:

- a) Horizontal
- b) Vertical
- c) Inclined

## 5. According to the position of furnace:

- a) **Internally fired:** The furnace is located inside the shell. Ex: Cochran, Lancashire boiler etc.
  - b) **Externally fired:** The furnace is located outside the boiler shell. Ex: Babcock and Wilcox, Stirling boiler etc.
- ## 6. According to pressure of steam generated:
- a) **Low pressure boiler:** A boiler which produces steam at pressure of 15-20 bar is called a low pressure boiler. This steam is used for process heating.
  - b) **Medium pressure boiler:** It has a working pressure of steam from 20 bar to 80 bar and is used for power generation or combined use of power generation and process heating.
  - c) **High pressure boiler:** It produces steam at a pressure of more than 80 bar.
  - d) **Sub critical boiler:** If a boiler produces steam at a pressure which is less than the critical pressure, is called subcritical boiler.
  - e) **Supercritical boiler:** The boiler produces steam at a pressure greater than critical pressure. These boilers don't have an evaporator and the water directly flashes into steam and thus they are called once through boiler.

## 7. According to the charge in the boiler:

- a) Pulverised fuel
- b) Supercharged fuel
- c) Fluidised bed combustion boiler

## 8. According to number of tubes:

- a) Single tube boiler
  - b) Multitubular boiler
-

# THERMAL ENGINEERING - II

Fire tube boiler	Water tube boiler
i. The hot fuel gases pass through tubes and water surrounds them.	i. Water passes through tubes and hot fuel gases surround them.
ii. These are operated at low pressure upto 20 bar.	ii. The working pressure is high enough upto 250 bar in super critical boiler.
iii. The rate of steam generation and quality of steam are low, therefore not suitable for power generation.	iii. The rate of steam generation and quality of steam are better & suitable for power generation.
iv. It requires more floor area for a given output.	iv. It requires less floor area for given output.
v. Overall efficiency is upto 75%.	v. Overall efficiency with an economiser is upto 90%.
vi. Used in process industry.	vi. Used in large power plant.

## 1. Cochran boiler:

### a) Construction and operation:

- It is a vertical, coal or oil fired, fire tube boiler.
- It is the modification of a simple vertical boiler with increase in the heating surface area.
- The fuel gases from the furnace are passes through a number of small tubes surrounded by gas.
- A Cochran boiler consists of a cylindrical shell with a hemispherical crown, grating, fire box, combustion chamber, number of smoke tubes, smoke box, chimney and various mounting.
- The grate is placed at the bottom of the hemispherical furnace. The coal is fed into the grate through the fire door and ash formed is collected in ash pit located just below the grate and then it is removed manually.

### b) Working:

## THERMAL ENGINEERING - II

- The fuel is burnt on grating. The hot fuel gases pass through a short fuel to a combustion chamber, small horizontal smoke tubes and are then collected in the smoke box, from where they are discharged to the atmosphere through the chimney.
- The heat is transferred to water by radiation through the dome of the fire place and by convection from the walls of the smoke tubes.
- On heating the water is vaporized and converted into steam. The generated steam is collected in the steam space above the water. This steam is then taken for use through the main steam stop valve.
- The man hole is provided in the crown of boiler for periodic cleaning and maintenance. A mud hole is provided at the bottom for draining out the muddy water from the boiler. The pressure gauge, water gauge, blow off cock, feed check valve, feed pump, fusible plug and chimney are provided for proper functioning of the boiler.

### c) **Salient features:**

- The spherical crown and spherical shape of a fire box are the special features of this boiler. These shapes require least material for a given volume.
- It is very compact and requires minimum floor area.
- It is well suited for small industries.

### 2. **Lancashire Boiler:**

- It is a horizontal, internally fired fire tube, natural circulation, stationary boiler. It is a widely used boiler due to its good steam generation capacity.

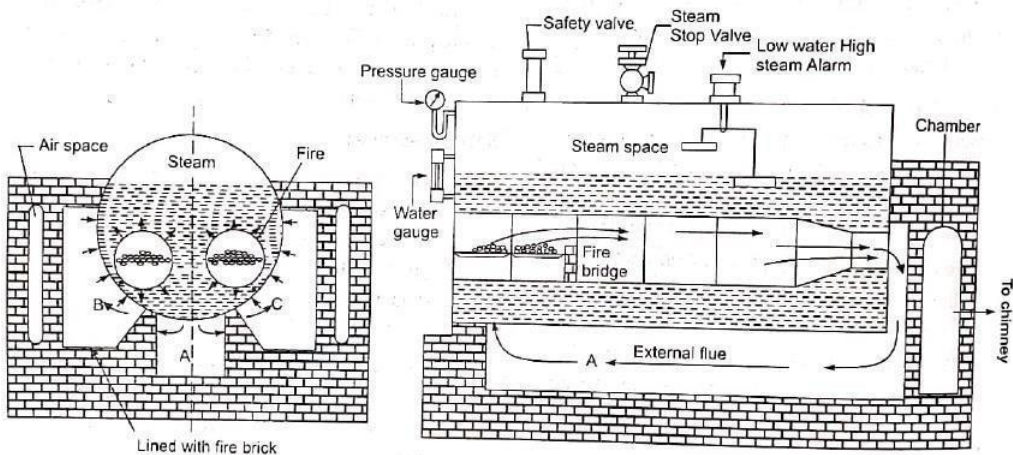
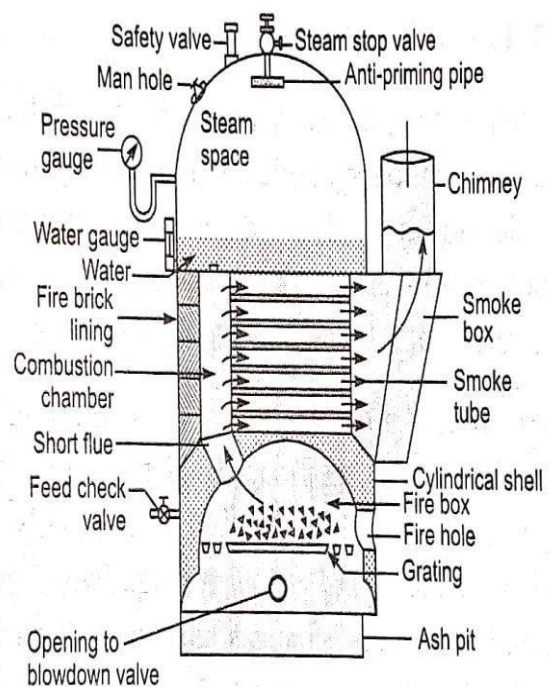



## THERMAL ENGINEERING - II

a) Construction:

## THERMAL ENGINEERING - II

- The boiler consists of a large shell supported by refractory brick masonry.
- The cylindrical shell is usually 2 to 3 m diameter and 7 to 9 m long.
- Two large, horizontal and parallel flue gas tubes pass through shell. The fire place is located in front of the flue tubes.
- In brick work, a flue passage A below the boiler shell, two flue passage B and C are connected to a chamber and then to the chimney.
- The dampers in the form of sliding doors are located at the end of side flues to control the flow of gases. They regulate the combustion rate as well as steam-generation rate. These dampers are operated by a chain passing over a pulley at the front of the boiler.
- The boiler is also provided with usual mountings like pressure gauge, water level indicator, steam stop valve, safety valve, low water and high steam safety valve, manhole on the top of the shell. The low water and high steam alarm gives an audio signal for low water level and high steam pressure.

### b) **Working:**

- The fuel is burnt at the grating and hot flue gases travel along internal flue tubes followed by flue passage A and then inside passages B and C.
- The flue gases are then collected in the chamber before they lead to the atmosphere through chimney.
- The hot flue gases transfer its maximum heat contents to water during its long passages.
- The water is converted into steam and collected in the steam space in the shell and it is then taken out through the steam stop valve.

### c) **Special features:**

- Its heating surface area per unit volume is considerably large.
- Its maintenance is easy.
- This boiler can easily handle the load fluctuation to large steam capacity.
- It is highly suitable for process industries.

### 3. **Babcock and Wilcox Boiler**

- It is a water tube boiler.

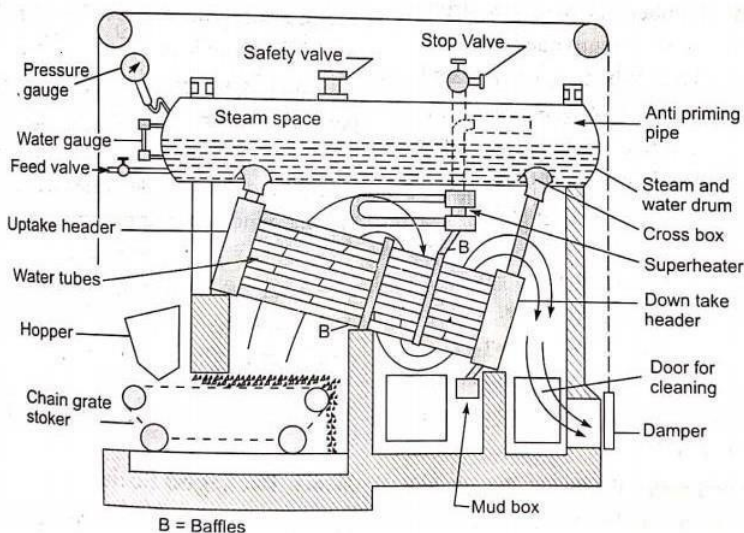

# THERMAL ENGINEERING - II

## a) **Construction:**

### *i. A horizontal steam and water drum:*

- This is the main part of the boiler. It is supported by steel structure at a certain height and is independent of brick works.
- It contains water steam.

### *ii. A bundle of steel tubes:*

- The front end of the boiler drum is connected to the uptake header by a short tube and the rear end is connected to the downtake header by a long tube.
- In between the headers, a number of small diameter steel tubes are fitted at an angle of  $5^{\circ}$  to  $15^{\circ}$  with the horizontal to promote the water circulation.

### *iii. Combustion chamber:*

- It is the space above the grate, below the front end of the drum where combustion of fuel takes place.
- This chamber is enclosed by brickwork and it is lined from inside by fire bricks. Doors are provided to give access for cleaning, inspection and repairing.
- The combustion is divided into three separate compartments by baffles. Thus, the first compartment above the furnace is hottest and the last chamber is of lowest temperature.
- This makes the path of hot gases longer before leaving the boiler through the chimney. The superheater is placed between the drum and water tubes.
- During the first turn of the hot gases, the gases are passed over super heater tubes.
- Dampers are provided at the rear end of the chamber to regulate the fresh air supply for maintaining proper combustion of fuel.

### *iv. Safety and control devices:*

- Safety and control devices are called mountings, as basically these devices are mounted over a boiler drum. These are the safety valves, pressure gauge, water-level indicator, blow-off cock, fusible plug and man hole.

## b) **Operation**

- The water is pumped by a feed pump and it enters the drum through a feed check valve up to the prescribed level so that the headers and the tubes are flooded always.
- When the combustion takes place above the grate, the product of hot gases comes out and rush through each compartment of the combustion chamber.
- Hence, the front portion of the tubes has the highest temperature and the rear portion has the lowest.
- When water is heated inside the tubes, it becomes lighter and rises up in the tube.
- Due to continuous heat supply, some of the water gets vaporized into steam inside the tubes and the mixture of water and steam enters the boiler drum through the uptake header.
- The cold water from the boiler drum comes down through the downtake header and enters the lower end of the water tubes for getting heated further.
- The natural circulation of water remains continuous due to difference in temperature. Such a

## THERMAL ENGINEERING - II

circulation is called thermo-siphon system.

- The steam generated gets collected in the steam space above water space in the boiler drum.

# THERMAL ENGINEERING - II

- In order to remove all water particles from the system, it is finally passed through the superheated tubes for its superheating. The superheated steam is then available for use.

## c) Special Features

- Its evaporating capacity is quite high compared to other boilers (20,000 to 40,000 kg/hr). The operating pressure lies between 11.5 to 17.5 hr.
- Drought losses are minimum.
- The defective tubes can be replaced easily.

## Boiler Mountings

- The fittings which are primarily indicated for the safety of the boiler, and for complete control of the process of steam generation are called mountings.
- The mountings form an integral part of the boiler and are mounted on the boiler itself.
- The following mountings are usually installed on the boiler:
  1. Safety Valve 2 numbers
  2. Water level indicator 2 numbers
  3. Fusible plug
  4. Pressure gauge
  5. Steam stop valve
  6. Feed check valve
  7. Blow off cock
  8. Man and mud hole

### 1. Safety Valve

- Safety valves are located on the top of the boiler. They guard the boiler with excessive high pressure of steam inside the boiler.
- If the pressure of the steam in the boiler drum exceeds the working pressure and the safety valve allows to blow off a certain quantity of steam to the atmosphere, and thus the pressure of steam falls in the drum.
- The safety valve operates on the principle that, a valve is placed against its seat through some agency such as strut, screw or spring by external weight or force, when the steam forced due to boiler pressure acting under the valve exceeds the external force, the valve gets lifted off from its seat and some of the steam rushes out until normal pressure is restored again.
- These are four types of safety valves:
  - a) Dead weight safety valve
  - b) Spring loaded safety valve
  - c) Lever loaded safety valve
  - d) High steam and low water safety valve.

### 2. Water Level Indicator

- Its function is to ascertain constantly and exactly the level of water in the boiler shell.

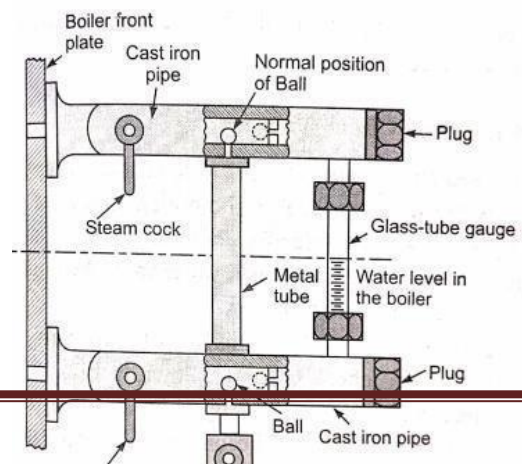

- It is fitted in front of the boiler where it is easily visible to the operator. Two water level indicators are used on all boilers.
- A water level indicator consists of a metal tube and a strong glass tube with markings. The upper and lower ends of these are connected to two gun metal hollow pipes.
- The upper pipe has a steam cock and the lower pipe has a water cock which are bolted to the boiler plate by two flanges.
- The upper pipe is opened to steam and the lower pipe is opened to water with the help of steam and water cocks respectively. The drain cock is used frequently to ensure that the water and steam cocks are clear.
- During the boiler operation, the steam cock and water cock remain opened while the drain cock is kept closed.
- During the normal operation, the two balls provided inside the gun metal pipe remain in position as shown in figure. Hence, the water can reach the glass gauge and its level can be seen.
- In case of glass gauge breaks accidentally, the water and steam simultaneously rush out through the gun metal pipes. The force is exerted on two balls and they are carried away by water and steam and the passages are closed.
- The water and steam cocks are then closed and the glass gauge is replaced.

### **3. Pressure Gauge**

- A pressure gauge is fitted in front of the boiler in such a position that the operator can conveniently read it. It reads the pressure of steam in the boiler and is connected to the steam space by a siphon tube.
- The most commonly used gauge is the Bourdon Pressure Gauge. It consists of an elliptical spring, Bourdon tube. One end of this tube is connected to the siphon tube and the other is connected by levers and gears to the pointer.
- When fluid pressure acts on the Bourdon tube, it tries to make its cross section change from elliptical to circular. In this process, the lever end of the tube moves out as indicated by an arrow. The tube movement is magnified by the mechanism and given to pointer to move over a circular scale indicating the pressure.

## THERMAL ENGINEERING - II

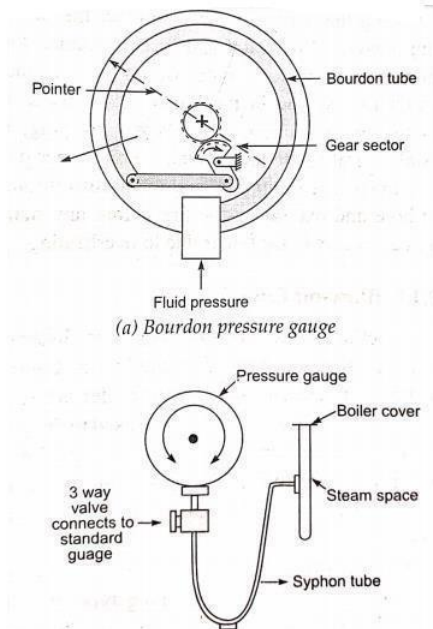

- The syphon tube connects the steam space of the boiler to the Bourdon gauge is filled with water in order to avoid the effect of high temperature steam on the gauge components. The steam pressure is transferred by water to the Bourdon pressure gauge.

### 4. Fusible Plug

- It is an important safety device which protects the fire tube boiler shell against overheating. It is located just above the furnace in the boiler.
- It consists of gun metal plug fixed in a gun metal body with a fusible molten metal as shown in figure.
- During the normal boiler operation, the fusible plug is covered by the water and its temperature does not rise to its melting state.
- But when the water level falls too low in the boiler, it uncovers the fusible plug. The furnace gases heat up the plug, the fusible metal of the plug melts and the inner plug falls down.
- The water and steam then rushes through the hole and extinguish the fire before any major damage occurs to the boiler due to overheating.

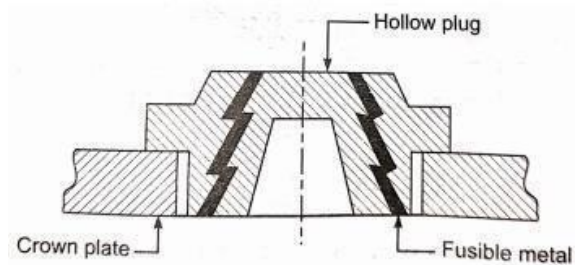

### 5. Blow Off Cock

- The function of the blow off cock is to discharge mud and other sediments deposited in the bottommost part of the water space in the boiler, while the boiler is in operation.
- It can also be used to drain up the boiler water. Hence, it is mounted at the lowest part of the boiler. When it is open, the water under the pressure rushes out, thus carrying sediments and mud.
- The blow off cock consists of conical hollow gunmetal plug type valve, which fits accurately into

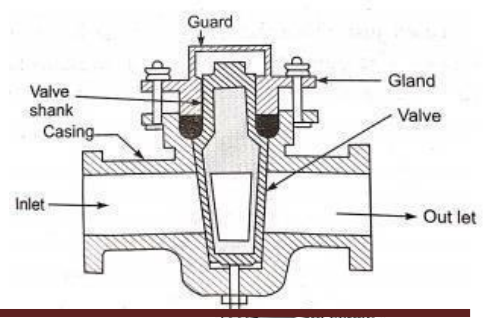

## THERMAL ENGINEERING - II

the corresponding hole in the casing. The plug valve has a hole, which when brought in line with the hole in the casing, by rotating the plug, causes the water to flow out of the boiler.

- The flow of water through the cock can be stopped by rotating the plug valve in such a way that its solid side comes in the line of the hole in the casing.

### 6. Feed check valve:

- The feed check valve is fitted to the boiler, slightly below the working level in the boiler.
- It is used to supply high pressure feed water to the boiler. It also prevents the returning of feed water from the boiler if the feed pump fails to work.
- A feed check valve consists of two valves: feed valve and check valve as shown in the figure. The feed valve is operated by a hand wheel for its opening and closing. The check valve operates automatically on its seat, up and down under the pressure difference of water.
- In normal working, the feed-water pressure is more than the boiler pressure, thus the check valve remains open.
- But in case of failure, the boiler pressure becomes more than the feed water, the valve rests on its seat and closes the water passage and prevents its reverse flow.

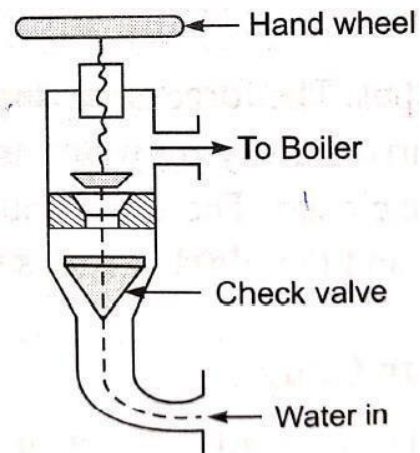

### 7. Steam stop valve:

- The steam stop valve is located on the highest part of the steam space. It regulates the steam supply for use. The steam stop valve can be operated manually or automatically.
- A hand operated steam stop valve is shown in the figure. It consists of a cast iron body and two flanges at right angles.
- One flange is fastened to the boiler shell and the other is fastened to the steam pipe.
- A steel valve connects the hand wheel through the spindle.
- When the hand wheel is rotated, the spindle also rotates and carries the valve up or down to open or close the valve. The spindle passes through a stuffing box and glands in order to prevent leakage.
- When the spindle is rotated anticlockwise, the valve lifts up and steam is allowed to pass through the clearance between the valve and its seat.
- The amount of steam passing the valve is controlled by the valve lift.

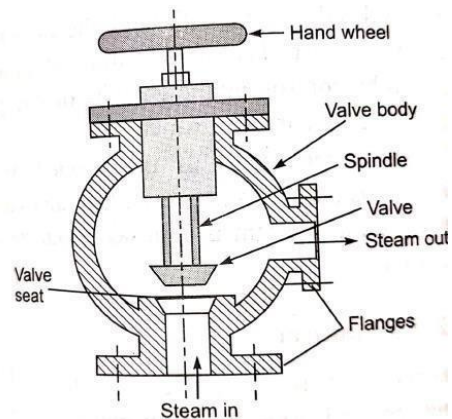



# THERMAL ENGINEERING - II

- When the hand wheel is rotated clockwise, the valve rests on its seat and closes the steam passage.

## 8. Man hole and mud box:

- The man hole is provided on the boiler shell at a convenient position so that a person can enter through it, inside the boiler for cleaning and inspection purpose.
- The mud box is placed at the bottom of the boiler to collect mud discharged through the blow off cock. Therefore, it is connected with the blow off cock.

## Boiler accessories:

- The categories include the components which are installed to increase the efficiency of the steam power plants and help in the power working of the boiler unit. These fittings are called boiler accessories.
- These are the devices which are used as integral parts of boiler, and help in running efficiently.
- Though there are many types of boiler accessories, yet the following are important:
  1. Superheater
  2. Economizer
  3. Air preheater
  4. Feed pump
  5. Steam injector

## 1. Superheater:

- It is a heat exchanger in which products of heat of combustion are utilized to dry the wet steam and to make it superheated by increasing its temperature.
  - During superheating of the steam, pressure remains constant, and its volume and temperature increase.
  - A superheater consists of a set of small diameter U tube in which steam flows and takes up the heat from hot flue gases.
  - Superheaters are classified as convective, radiant and of combination types.
  - In the convective superheater, the heat of the hot flue gases is transferred to the surface of the superheater by convection. These are located in the path of hot flue gases.
  - In a radiant superheater, the heat of the combustion is transferred to the surface of the superheater by thermal radiation. These are located in one or more walls of the furnace. These are used in high-pressure boilers.
  - In a combination type of superheater, the heat is transferred to the surface of the tubes by both modes of heat transfer.
  - Figure below shows a schematic of Surgden's superheater. It consists of two mild steel headers. The U-shaped steel tubes are connected to these headers.
  - The steam generated into the boiler passes the valve C and enters the superheater (U) tube through the intake header.
  - The steam is made dry and superheated in these tubes by supplying heat and then it is taken for use
-

# THERMAL ENGINEERING - II

through the valve B via the uptake header.



# THERMAL ENGINEERING - II

- The superheating of steam is controlled by controlling the quantity of flue gases by operating the dampers manually.
- If superheated steam is not needed or the superheater is under maintenance, the valves Band C are closed and steam is then taken out through the valve A.

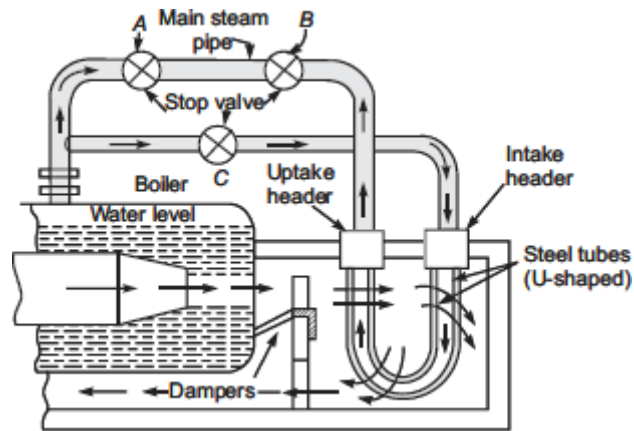

## 2. Economizer:

- An economizer is a heat exchanger used for heating the feed water before it enters the boiler.
  - The economizer recovers some of waste heat of hot flue gases going to the chimney thus it helps in improving the boiler efficiency.
  - It is placed in the path of flue gases at the rear end of the boiler just before the air preheater.
  - The most popular economizer is Green's economizer and it is shown below.
  - Green's economizer consists of a set of vertical cast-iron pipes joined with horizontal lower and upper headers.
  - The cold feed water flows through the vertical pipes via the lower header. The hot flue gases pass over them transferring heat to the water.
  - The heated water is supplied to the boiler via the upper header.
  - The scrappers are provided on pipes, which move up and down slowly by means of chains and sprockets to avoid the soot deposition on the pipe surface.
  - The soot collected in the soot chamber can be removed from the door.
  - Each economizer is equipped with a safety valve, a drain valve, a release valve, pressure gauge and thermometers.
-

# THERMAL ENGINEERING - II

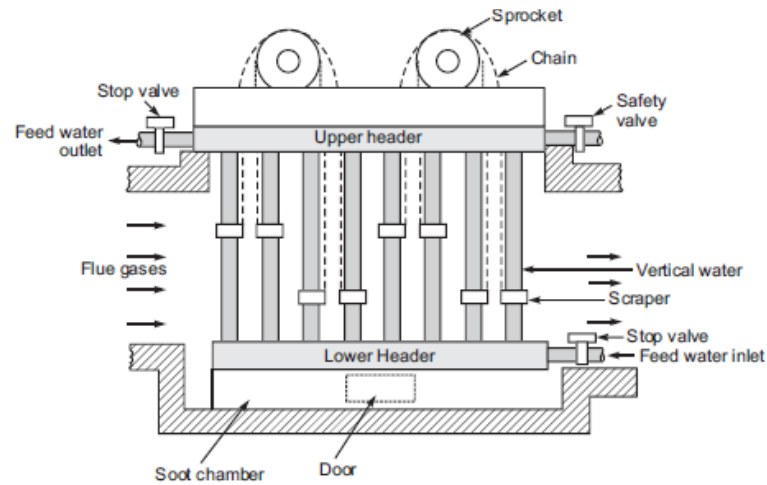

### 3. Air preheater:

- The function of an air preheater is similar to that of an economizer.
- It recovers some portion of the waste heat of hot flue gases going to the chimney, and transfers the same to the fresh air before it enters the combustion chamber. A tubular airpreheater is shown below.
- Due to preheating of air, the furnace temperature increases. It results in rapid combustion of fuel with less soot, smoke and ash.
- The high furnace temperature can permit a low-grade fuel with less atmospheric pollution. The air preheater is placed between the economizer and chimney.

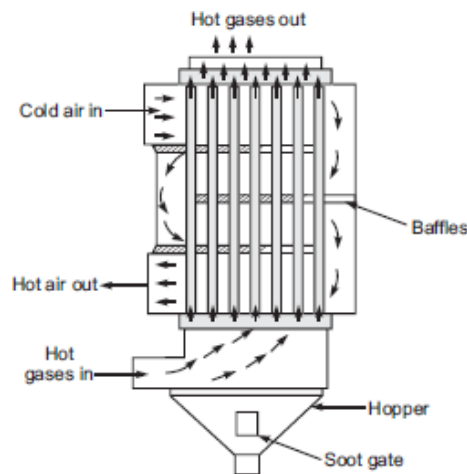

### 4. Feed pump:

- We know that water, in a boiler is continuously converted into steam, which is used by the engine. Thus, we need a feed pump to deliver water to the boiler.
  - The pressure of steam inside the boiler is high. So the pressure of feed water has to be increased proportionately before it is made to enter the boiler.
  - A feed pump may be of centrifugal type or reciprocating type. But a double acting reciprocating pump is commonly used as a feed pump these days.
  - The reciprocating pumps are run by the steam from the same boiler in which water is to be fed.
-

## THERMAL ENGINEERING - II

- The pumps may be classified as simplex, duplex and triplex pumps according to the number of pump cylinders.
- The common type of pump used is a duplex feed pump as shown in the figure. This pump has two sets of suction and delivery valves for forward and backward strokes. The two pumps work alternately so as to ensure continuous supply of feed water.

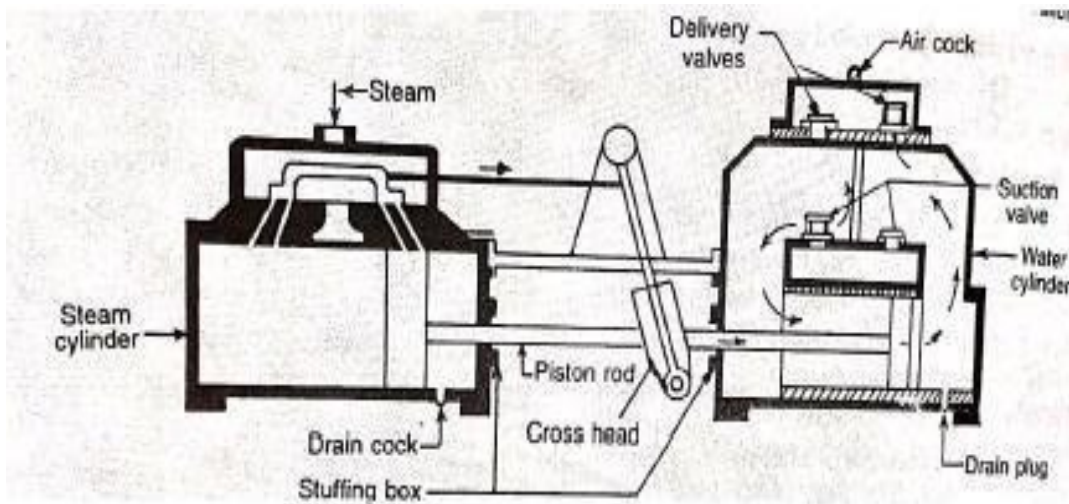

### 5. Steam separator:

- A steam separator is installed on the steam main as well as on the branch lines to separate any water particles present from the steam going to the units.
- It is installed very close to units on main steam pipes.
- By change of direction of steam, steam separators cause the condensed water particles to be separated out and delivered to a point where they can be drained away as condensate through a conventional steam trap.

### Boiler draught (Draft):

- The boiler draught may be defined as the small pressure difference which causes the continuous flow of gases inside the boiler.
- In other words, the draught is a small pressure difference between the air outside the boiler and goes within the furnace or chimney.

### Function of draught:

- The boiler draught performs the following functions:
- It forces a sufficient quantity of air into the furnace for proper combustion of fuel.
- It circulates the hot flue gases through the flue tubes, superheater, economizer, air preheater.
- It discharges the hot flue gases to the atmosphere through the chimney

### Classification of Boiler draught:

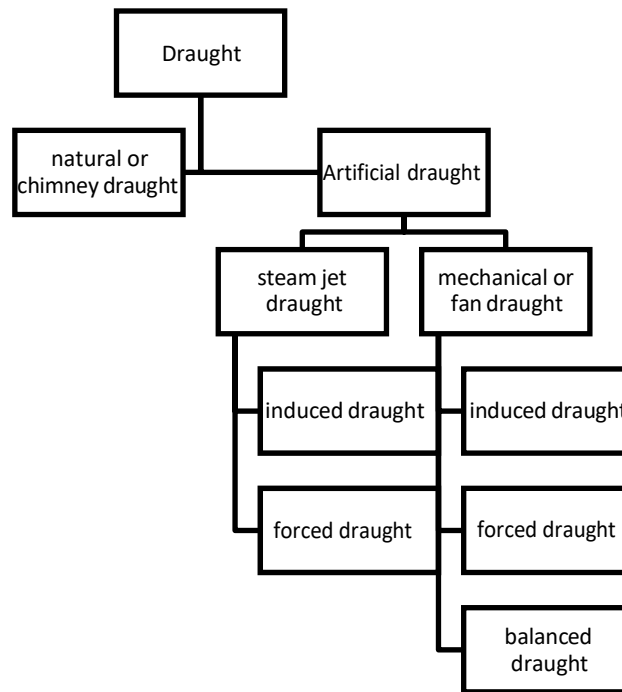

## Natural or chimney draught:

- The draught obtained by the use of a chimney is called natural or chimney draught.

## Artificial draught:

- An artificial draught produced by a fan or a blower is known as mechanical draught and that produced by steam jet is known as steam jet draught.

## Mechanical draught:

- Draught produced by a fan or blower may be of three types:
- Induced, forced and balanced

## Induced draught:

- The fan is placed near the base of chimney as shown in the figure.
- The fan draws the flue gases from the furnace so the pressure above the fuel bed is reduced below the atmospheric pressure.
- The fresh air rushes to the furnace and after combustion, the flue gases get discharged through chimney in the atmosphere.

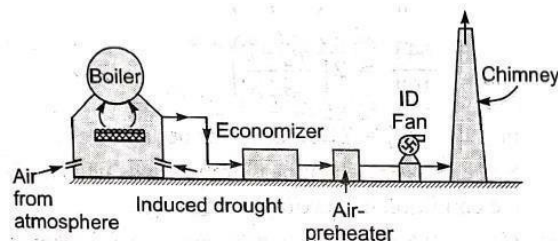

# THERMAL ENGINEERING - II

## Forced draught:

- The fan or blower is located near or at the base of the boiler grate to force atmospheric air into the furnace under pressure.
- This pressure helps in circulation of flue gases through the components of boiler and then through chimney to atmosphere. It is shown in the figure below.

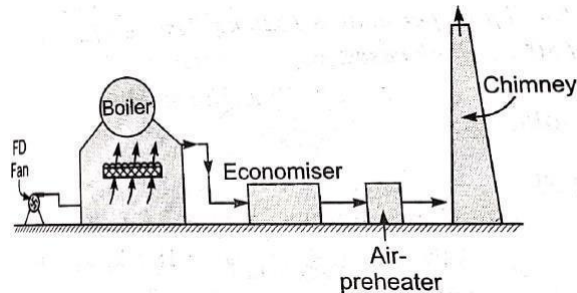

## Balanced draught:

- A combination of induced and forced draught in a boiler is known as a balanced draught.
- A forced draught fan located near the grate supplies air under the pressure through the furnace and an induced draught fan located near the chimney base draws in flue gases through the economiser, air preheater, etc and discharges them into the atmosphere through a chimney. Figure below shows balanced draught system.

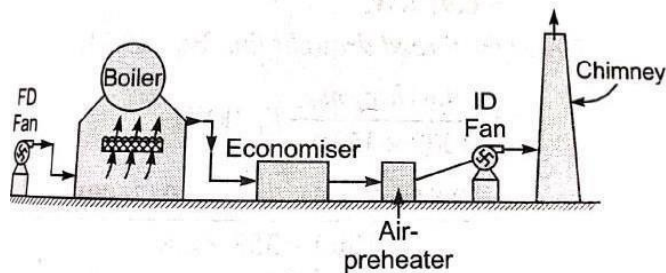

## CH-5 (STEAM POWER CYCLE)

### Thermodynamic Cycle:

- When a system is undergoing a series of processes and restoring its initial state then the system is undergoing a thermodynamic cycle.
- Thermodynamic cycles can be divided into two general categories: power cycles and refrigeration cycles.

The devices or systems used to produce a net power output are often called engines, and the thermodynamic cycles they operate on are called power cycles.

The devices or systems used to produce a refrigeration effect are called refrigerators, air conditioners or heat pumps, and the cycles they operate on are called refrigeration cycles.

---

# THERMAL ENGINEERING - II

- Thermodynamic cycle can also be categorized as gas cycles and vapour cycles, depending on the phase of the working fluid.  
In gas cycles, the working fluid remains in the gaseous phase throughout the entire cycle, whereas in vapour cycles the working fluid exists in the vapour phase during one part of the cycle and in the liquid phase during another part.
- Thermodynamic cycles can be categorized yet another way: closed and open cycles.  
In closed cycles, the working fluid is returned to the initial state at the end of the cycle and is recirculated.  
In open cycles, the working fluid is renewed at the end of the cycle instead of being recirculated.

## Vapour Power Cycle:

- Working fluid is alternatively vaporized and condensed.
  - Steam is the most common working fluid used in vapour power cycles because of its many desirable characteristics, such as-
    - i. low cost,
    - ii. availability and
    - iii. high enthalpy of vaporization.
- ❖ Steam power plants are commonly referred to as coal plants, nuclear plants, or natural gas plants, depending on the type of fuel used to supply heat to the steam.

## Carnot Vapour Power Cycle:

- It is a cycle, which has maximum efficiency, operating between given temperature limits and its efficiency is independent of properties of working fluid.

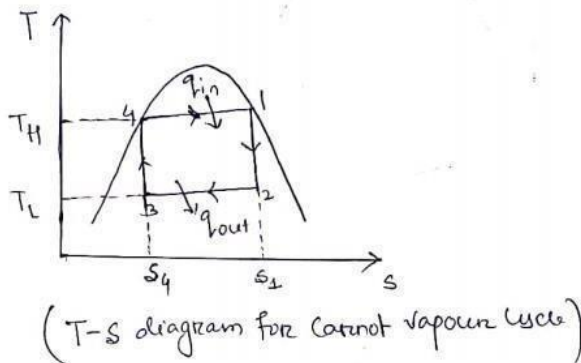

Basic processes in Carnot vapour cycles are 1-2:

reversible adiabatic expansion

2-3: isothermal heat rejection

3-4 : reversible adiabatic compression

4-1: isothermal heat supply

- *Analysis of Carnot vapour power cycle:*
-



# THERMAL ENGINEERING - II

$$q_{in} = T(s_1 - s_2)$$

$$q_{out} = T(s_1 - s_4)$$

The net work done of the cycle

$$\begin{aligned} W_{net} &= q_{in} - q_{out} \\ &= T(s_1 - s_2) - T_L(s_1 - s_4) \\ W_{net} &= (T_H - T_L)(s_1 - s_4) \end{aligned}$$

The thermal efficiency of the cycle;

$$\begin{aligned} \eta_{carnot} &= \frac{W_{net}}{q_{in}} \\ &= \frac{(T_H - T_L)(s_1 - s_4)}{\frac{T_H(s_1 - s_2)}{T_L}} \\ \eta_{carnot} &= 1 - \frac{T_L}{T_H} \end{aligned}$$

- Practical impracticalities associated with Carnot vapour cycle:
  - i. Isothermal heat transfer to or from a two phase system is not difficult to achieve in practice since maintaining a constant pressure in the device automatically fixes the temperature at the saturation value.  
But heat transfer process in two phase limits the maximum operating temperature in the cycle, thus limiting the thermal efficiency.
  - ii. In the turbine; the dry saturated steam expands isentropically. The quality of steam decreases during expansion. The presence of high moisture content in the steam will lead to erosion and wear of turbine blades.
  - iii. The isentropic compression process (process 3-4) involves the compression of a liquid-vapour mixture to a saturated liquid.  
There are two difficulties associated with the process-
    - a) First, it is not easy to control the condensation process so precisely as to end up with the desired quantity at state 3.
    - b) Second, it is not practical to design a compressor that handles two phases.

## Rankine Cycle: The Ideal Cycle for vapour Power Cycles:

- Many of the practical difficulties associated with the Carnot vapour cycle are eliminated in Rankine cycle.
- The steam coming out of the boiler is usually superheated state, and expands in the turbine.

### Simple steam power plant

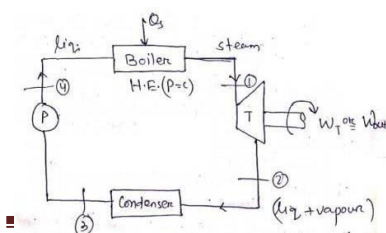

## THERMAL ENGINEERING - II

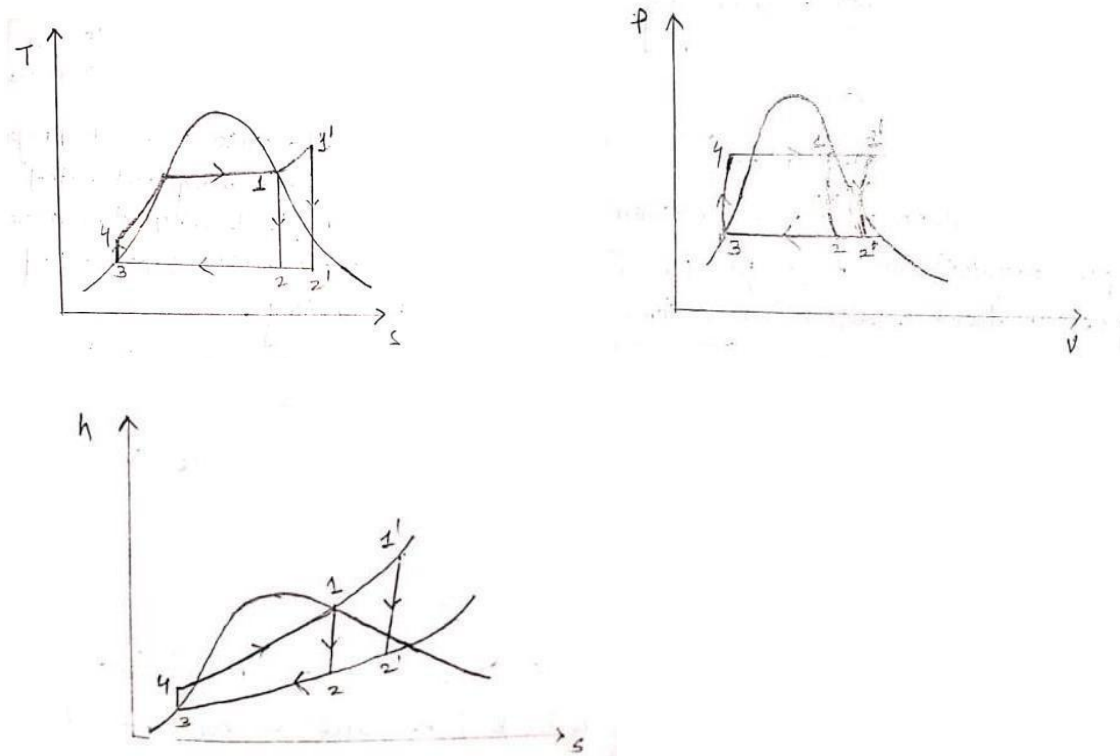

- The above figure shows the Rankine cycle on T-s coordinates, P-v coordinates and h-s coordinates.
- In all three diagrams, the cycle 1-2-3-4-1 represents an ideal Rankine cycle using saturated steam and the cycle 1'-2'-3'-4'-1' represents an ideal Rankine cycle with superheated steam at the turbine entry.
- The ideal Rankine cycle does not involve any internal irreversibilities and consists of the following four processes:
  - 1-2: Isentropic expansion in a turbine
  - 2-3: Constant pressure heat rejection in a condenser
  - 3-4: Isentropic compression in a pump
  - 4-1: Constant pressure heat addition in a boiler

➤ **Thermal Efficiency of Ideal Rankine Cycle:**

Assumptions:

1. Each device is steady flow device.
2. All the processes are internally reversible.
3. Changes in K.E. and P.E. are neglected.
4. Complete cycle is a closed system.

S.F.E.E.(for 1 kg fluid)

$$h_1 + \frac{c_1^2}{2} + gz_1 + q = h_2 + \frac{c_2^2}{2} + gz_2 + w \quad \text{c.v.}$$

$$d(K.E. \& P.E.) \approx 0$$

# THERMAL ENGINEERING - II

Therefore, S.F.E.E.

$$h_1 + q = h_2 + w_{c.v.}$$

I. Turbine:

$$h_1 = h_2 + w_T$$

$$w_T = h_1 - h_2$$

II. Condenser:

$$h_2 + q_R = h_3$$

$$(-)q_R = h_3 - h_2$$

$$q_R = h_2 - h_3$$

III. Pump:

$$h_3 = h_4 + w_p$$

$$(-)w_p = h_3 - h_4$$

$$w_p = h_4 - h_3$$

IV. Boiler:

$$h_4 + q_s = h_1$$

$$q_s = h_1 - h_4$$

The efficiency of the Rankine cycle is then given by-

$$\eta_{th \text{ simple Rankine}} = \frac{w_{net}}{q_s} = \frac{w_T - w_p}{q_s}$$

$$\eta_{th \text{ simple Rankine}} = \frac{(h_1 - h_2) - (h_4 - h_3)}{h_1 - h_4}$$

or

$$\eta_{th \text{ simple Rankine}} = \frac{w_{net}}{q_s} = \frac{q_s - q}{q_s} = 1 - \frac{q_R}{q_s}$$

$$\eta_{th \text{ simple Rankine}} = 1 - \frac{(h_2 - h_3)}{h_1 - h_4}$$

## **Reheat cycle:**

- If the steam expands completely in a single stage then steam coming out the turbine is very wet. The wet steam carries suspended moisture particles, which are heavier than the vapour particles, thus deposited on the blades and causing its erosion.
  - In order to increase the life of turbine blades, it is necessary to keep the steam dry during its expansion.
-

## THERMAL ENGINEERING - II

- It is done by allowing the steam to expand to an intermediate pressure in a high pressure turbine, and then taking it out and sending back to the boiler, where it is reheated at constant pressure until it reaches the inlet temperature of the first stage.
- This process is called reheating during which heat is added to the steam.

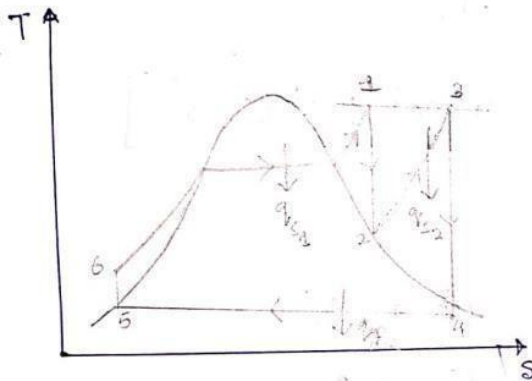
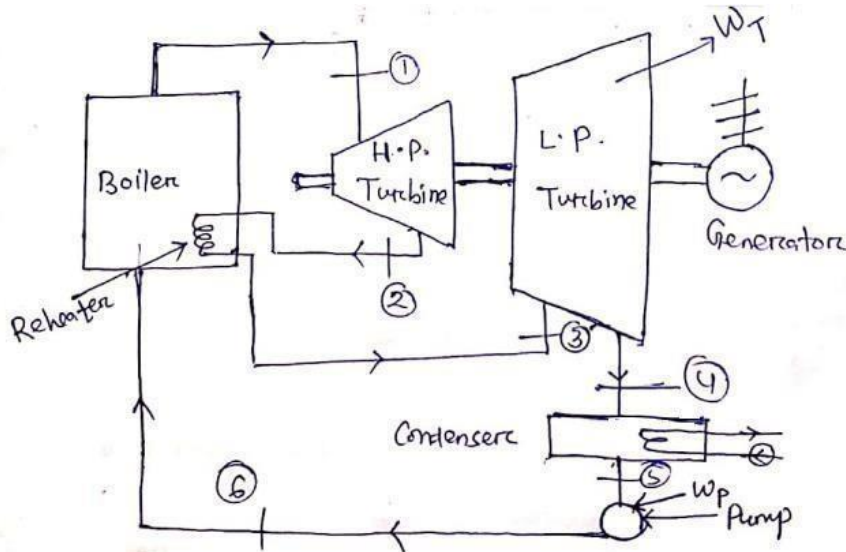

- In the reheat cycle the expansion of steam from the initial state 1 to the condenser pressure is carried out in two or more steps, depending upon the number of reheat used.
- In the first step, steam expands in high pressure (H.P.) turbine from the initial state to approximately the saturated vapour line (process 1-2).
- The steam is then resuperheated (or reheated) at constant pressure in the boiler (process 2-3) and the remaining expansion (process 3-4) is carried out in low pressure (L.P.) turbine.
- In the case of use of two reheats, steam is reheated twice at different constant pressure.
- *Thermal efficiency*

$$\eta_{th} = \frac{W_{net}}{q_s} = \frac{W_T - W_P}{q_s}$$

$$\eta_{th \text{ reheat Rankine}} = \frac{[(h_1 - h_2) - (h_3 - h_4)] - (h_6 - h_5)}{[(h_1 - h_2) + (h_3 - h_2)]}$$

# THERMAL ENGINEERING - II

## Note

- The main purpose of reheating in steam power plant is to increase the dryness fraction of steam at exit of turbine.
- In practice, the use of reheat only gives a small increase in cycle efficiency.

## Regenerative cycle:

- In simple Rankine cycle a significant amount of heat is added for sensible heating of compressed liquid coming out of the pump.
- The mean temperature at which sensible added is much lower than the source temperature.
- Thus, the efficiency of the Rankine cycle is much lower than that of Carnot vapour cycle.
- The efficiency of the Rankine cycle can be improved by heating the feed water regeneratively.

## *Ideal regenerative cycle*

- The unique feature of the ideal regeneratively cycle is that the condensate, after leaving the pump circulates around the turbine casing, counterflow to the direction of vapour flow in the turbine.
- Thus it is possible to transfer heat from the vapour as it flows through the turbine to the liquid flowing around turbine.
- Let us assume that this is a reversible heat transfer, i.e, at each point the temperature of vapour is only infinitesimally higher than the temperature of the liquid.
- The process 1-2' thus represents reversible expansion of steam in the turbine with reversible heat rejection.
- However, the cycle is not practicable for the following reasons:
  - i. Reversible heat transfer cannot be obtained in finite time.
  - ii. Heat exchanger in the turbine is mechanically impracticable.
  - iii. The moisture content of the steam in the turbine will be high.

A **practical regenerative process** in steam power plant is accomplished by extracting, or “bleeding” steam from the turbine at various points. This steam, which could have produced more work by expanding further in the turbine, is used to heat the feed water instead. The device where the feed- water is heated by regeneration is called regenerator or feed water heater (FWH). Regeneration not only improves cycle efficiency, but also provides a convenient means of deaerating the feed water to prevent corrosion in the boiler. It also helps control the large volume flow rate of the steam at the final stages of the turbine (due to the large specific volume at low pressure). A feed water heater is basically a heat exchanger where heat is transferred from the steam to the feed water either by mixing the two fluid streams (open feedwater heaters) or without mixing them (closed feedwater heaters) **Regeneration with open feedwater heater:**

- An open (or direct contact) feedwater heater is basically a mixing chamber, where the steam extracted from the turbine mixes with the feedwater exiting the pump.
-

## THERMAL ENGINEERING - II

- Ideally, the mixture leaves the heater as a saturated liquid at the heater pressure. The schematic of a steam power plant with one open feedwater (also called single stage regenerative cycle) and the T-s diagram of the cycle are shown.

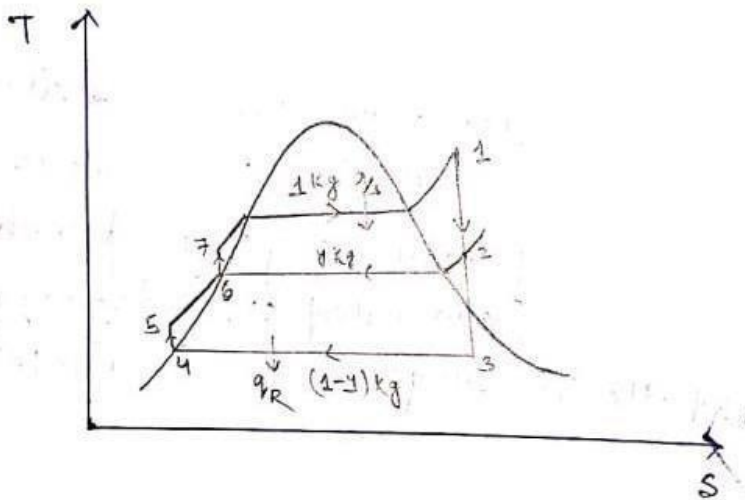
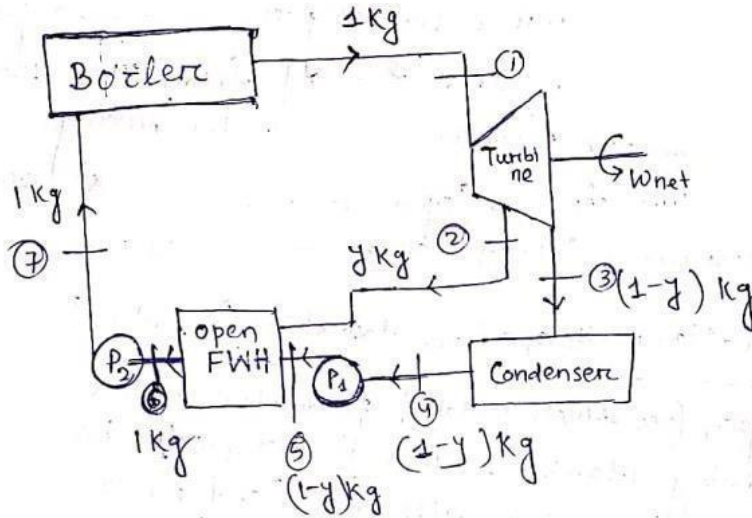

- A part of superheated steam which enters the turbine at the state-1, is extracted from the turbine at the intermediate state-2 of the turbine expansion process.
- The extracted steam is supplied to feedwater heater. The remaining amount of steam in the turbine expands completely to the condenser pressure (state-3).
- The condensate, a saturated liquid, at state-4 is pumped isentropically by low pressure (L.P.) pump to the pressure of extracted steam.
- The compressed liquid at the state-5 enters the feedwater heater and it mixes with steam extracted from the turbine.
- Due to direct mixing process, the feedwater heater is called open or direct-contact type feedwater heater.
- The portion of steam extracted steam is so adjusted to make the mixture leaving the feedwater to be saturated at state-6.

## THERMAL ENGINEERING - II

- Now this saturated water is pumped by high pressure (H.P.) pump to the boiler pressure state-7.
- With the regeneration, the average temperature at which heat is supplied has been increased, therefore Rankine cycle efficiency improves.

### **Regeneration with closed feedwater heater:**

- A closed feedwater heater, is an indirect contact type feedwater heater, usually a shell and tube type heat exchanger, in which heat is transferred from extracted steam to feedwater without mixing the two fluid streams.
- Thus, two fluid streams can be kept at different pressure.
- A regenerative vapour power cycle with one closed feedwater heater with the condensate trapped into the condenser is shown below.

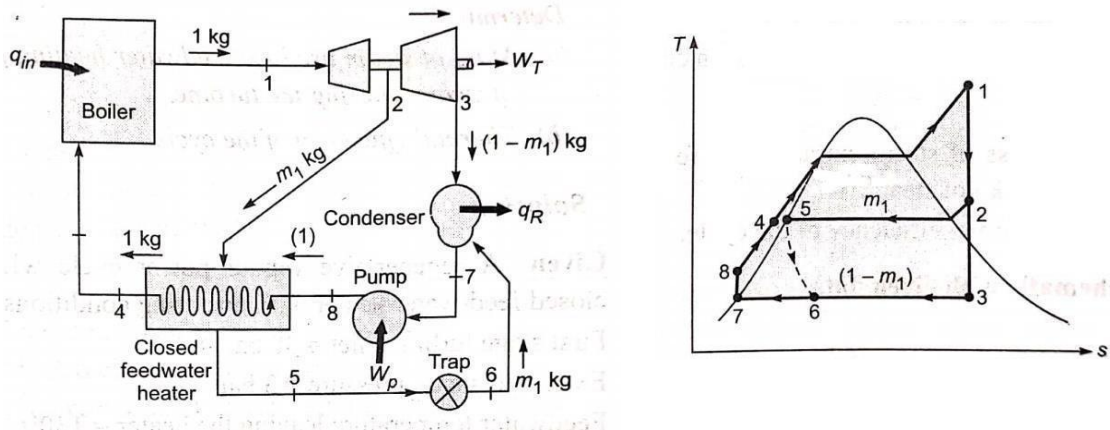

- As shown with the help of T-s diagram, the total steam expands through first stage turbine from state-1 to state-2.
- At state-2 a part of steam ( $m_1$  kg) is extracted and is supplied to closed feedwater heater, where it condenses, on outside of the tubes, carrying the feedwater.
- The saturated liquid at extraction pressure exits the feed water heater at state-5 and is routed to the condenser through trap, the steam is throttled from state-5 to state-6.

It is an irreversible process, and thus shown by dotted line.

- Then total condensate as saturated liquid at state-7 is pumped to boiler pressure and enters the feed water at state-8.
- The temperature of feed water in the heater is raised to state-4.
- The cycle completes as working fluid enters the boiler and heated at constant pressure from state-4 to state-1.

# THERMAL ENGINEERING - II

## CH-6 (HEAT TRANSFER)

### Why we need Heat Transfer?

- Thermodynamics deals with systems in equilibrium and calculates the energy transferred to change a system from one equilibrium state to another. However, it cannot tell the duration for which heat has to be flow to change the state of equilibrium.
- The science of heat transfer is concerned with the calculation of the rate at which heat flows within a medium, across an interface, or from one surface to another and associated temperature distribution.
- Analysis of heat transfer process requires the knowledge of TD because 1<sup>st</sup> law will give you idea about how much input required to do some work and 2<sup>nd</sup> law will give you direction of heat transfer.

### Note:

- ❖ Temperature difference is driving potential for heat transfer and mathematics is tool to analyze heat transfer.

### Modes of Heat Transfer:

#### 1. Conduction

- It is mode of heat transfer between higher energy particles to lower energy particles.
- Conduction of solid is basically due to
  - Lattice vibration (phonon)
  - Free flow of electrons (only in case of metals)
- Electrons are the energy carriers therefore metals are good conductors of heat.
- Conduction in fluid is basically due to collision in molecules and the energy transfer due to collision is known as diffusion heat transfer.
- Conduction effects are more in case of solids and least in case of gases.

#### 2. Convection

Conduction + Advection

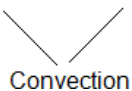

- It refers to heat transfer that will occur between a surface and adjacent moving medium, liquid or gas, when they are at different temperature.
  - Convection is a combination of conduction and fluid motion (advection).
  - Convection depends on operating temperature as well as fluid properties.
  - If the motion of the fluid develop because of density difference, then it is known as free convection or natural convection.
  - If the motion in a fluid develop with an external help like fan, compressor, etc then it is known forced convection.
-



# THERMAL ENGINEERING - II

- The convective rate of heat transfer is higher in forced convection compare to free convection.

### 3. Radiation

- According to Prevost law every substance above 0 Kelvin emits energy and from Maxwell theory that energy propagate in electromagnetic waves and we know that electromagnetic waves can travel with speed of light under vacuum condition. The energy transfer due to electromagnetic wave is known as radiation heat transfer.
- Radiation does not require any medium to propagate heat.
- Radiation is the fastest mode of heat transfer.

### Fourier's law of heat transfer

- It states that the rate of heat conduction per unit area (heat flux) is directly proportional to temperature gradient.

$$\frac{Q}{A} \propto \frac{dT}{dx}$$

Or

$$q = \frac{Q}{A} = k \frac{dT}{dx}$$
$$Q = -kA \frac{dT}{dx}$$

Where  $q$  = heat flux ( $\frac{W}{m^2}$ )

$Q$  = rate of heat transfer, W

$A$  = area normal to direction of heat flow,  $m^2$

$\frac{dT}{dx}$  = temperature gradient  $\frac{^\circ C}{m}$ , slope of temperature curve on T - x diagram

$k$  = constant of proportionality called thermal conductivity of material,  $\frac{W}{m^\circ C}$  or  $\frac{W}{mK}$

- The negative sign is inserted to make natural heat flow a positive quantity. According to the second law of thermodynamics, heat always flows in the direction of decreasing temperature.

Thus the temperature gradient  $\frac{dT}{dx}$  becomes negative.

### Thermal Conductivity (k):

- Thermal conductivity of a material can be defined as the rate of heat of heat transfer through a unit thickness of the material per unit area per unit temperature difference.

- It is the ability of material to conduct heat. It is the material property which is measured in  $\frac{Watt}{mK}$

or  $\frac{Watt}{m^\circ C}$ .

$mK$

### Newton's law of cooling:

- It is governing equation of convection heat transfer.
- It states that rate of convection heat transfer is directly proportional to temperature difference between a surface and fluid. Mathematically

$Q$

---

# THERMAL ENGINEERING - II

$$A \ln \left( \frac{T_3 - T_2}{T_3 - T_1} \right)$$



## THERMAL ENGINEERING - II

$$\frac{Q'}{A} = h(T_s - T_\infty)$$

$$Q' = hA(T_s - T_\infty)$$

Where, h is the convection heat transfer coefficient in  $W/m^2 \cdot ^\circ C$

A is the surface area through which convection heat transfer takes place

$T_s$  is the surface temperature, and

$T_\infty$  is the temperature of the fluid

### Radiation heat transfer

#### Thermal radiation:

- Thermal radiation refers to the radiant energy emitted by bodies by virtue of their own temperature resulting from the thermal excitation of the molecules.
- Thermal radiation is generally described in terms of electromagnetic waves, all of which travel at the velocity of light.
- The wavelength and frequency of radiation propagating in medium are related by

$$c = \nu\lambda$$

Where,  $c$  is velocity of light in the medium,  $\nu$  is the frequency,  $\lambda$  is the wavelength. When the medium in which radiation travels is vacuum, the velocity of propagation is  $c = 2.9979 \times 10^8$  m/s.

#### Absorptivity, Reflectivity, and Transmissivity

- When radiation strikes a surface, part of it is absorbed, part of it is reflected, and the remaining part, if any, is transmitted, as illustrated in Figure
- The fraction of irradiation absorbed by the surface is called the absorptivity  $\alpha$ , the fraction reflected by the surface is called the reflectivity  $\rho$ , and the fraction transmitted is called the transmissivity  $r$ .

- Absorptivity:  $\alpha = \frac{\text{Absorbed radiation}}{\text{Incident radiation}} = \frac{G_{abs}}{G}$
- Reflectivity:  $\rho = \frac{\text{Reflected radiation}}{\text{Incident radiation}} = \frac{G_{ref}}{G}$
- Transmissivity:  $r = \frac{\text{Transmitted radiation}}{\text{Incident radiation}} = \frac{G_{tr}}{G}$

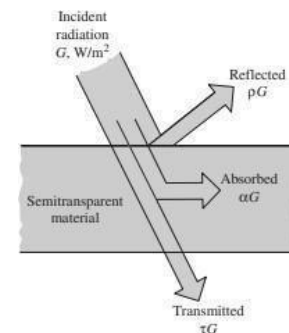

Where  $G$  is the radiation energy incident on the surface, and

$G_{abs}$ ,  $G_{ref}$ , and  $G_{tr}$  are the absorbed, reflected, and transmitted portions of it, respectively.

#### Note:

- $G_{abs} + G_{ref} + G_{tr} = G$

Dividing each term of this relation by  $G$  yields,  $\alpha + \rho + r = 1$

- For opaque surfaces,  $r = 0$ , and thus,  $\alpha + \rho = 1$
- These definitions are for total hemispherical properties, since  $G$  represents the radiation flux incident on the surface from all directions over the hemispherical space and over all

# THERMAL ENGINEERING - II

wavelengths. Thus,  $\alpha$ ,  $\rho$  and  $r$  are the average properties of a medium for all directions and all wavelengths.

## Black body radiation:

It is an ideal surface having the following properties:

- A black body absorbs all incident radiation from all directions at all wavelengths.
- At any temperature and wavelength, no body can emit energy more than a black body.
- A black body neither reflects nor transmits any amount of incident radiation.

$$\therefore \alpha = 1 \text{ \& } \rho = r = 0$$

## Emissive power:

- The total emissive power of a body,  $E$ , is defined as the total radiant energy emitted by the body at a certain temperature per unit time and per unit surface area at all wavelengths.
- The monochromatic emissive power of a body,  $E_\lambda$ , is defined as the radiant energy emitted by the body at a certain temperature per unit time and per unit surface area at a particular wavelength and temperature.
- The radiation energy emitted by a black per unit time and per unit surface area is given by

$$E_b = \sigma T^4 \left( \frac{W}{m^2} \right) \text{ --- (1)}$$

Where  $\sigma = 5.67 \times 10^8$   $\left( \frac{W}{m^2 K^4} \right)$  is called Stefan-Boltzmann constant and  $T$  is the absolute temperature of the surface in Kelvin.

The above equation (1) is called **Stefan-Boltzmann law** and  $E_b$  is called the total emissive power of a black body.

## Emissivity( $\epsilon$ )

- The emissivity of a surface is defined as the ratio of radiation emitted by surface to the radiation emitted by a black body at the same temperature. It varies between 0 and 1.

$$\epsilon = \frac{E}{E_b}$$

- Emissivity is a measure of how closely a surface approximates a black body for which  $\epsilon = 1$ .
- The emissivity of a real surface varies with the temperature of the surface as well as wavelength and direction of emitted radiation.
- The emissivity of a surface at a certain wavelength is called spectral emissivity ( $\epsilon_\lambda$ .)
- The emissivity in a certain direction is called directional emissivity  $\epsilon_\theta$  where  $\theta$  is the angle between the direction of radiation and the normal to the surface.
- The emissivity of a surface averaged over all directions is called the hemispherical emissivity and the emissivity averaged over all wavelengths is called the total emissivity.

## Kirchhoff's Law:

- It states that the emissivity of the surface of a black body is equal to its absorptivity when the body is in thermal equilibrium with its surrounding.
-